

LINEAR INTEGRATED CIRCUIT

TAA 550 TBA 271

VOLTAGE STABILIZER

- LOW TEMPERATURE COEFFICIENT
- LOW ZENER RESISTANCE

The TAA 550/TBA 271 is a monolithic integrated voltage stabilizer in a TO-18 two pins metal case. It is especially designed as voltage supplier for varicap diodes in television tuners.

The TAA 550/TBA 271 is supplied in 3 groups of stabilized voltage identified by a letter after the code, as shown in the "ORDERING NUMBERS".

ABSOLUTE MAXIMUM RATINGS

I_z	Zener current at $T_{case} \leq 70^\circ C$	15 mA
T_{stg}	Storage temperature	-20 to 150 °C
T_{op}	Operating temperature	*

* Refer to "Power rating chart" (Fig. 1)

ORDERING NUMBERS: TAA 550 A or TBA 271 A (for V_z range : 30-32 V)
TAA 550 B or TBA 271 B (for V_z range : 32-34 V)
TAA 550 C or TBA 271 C (for V_z range : 34-36 V)

MECHANICAL DATA

Dimensions in mm

Lead 1 connected to case

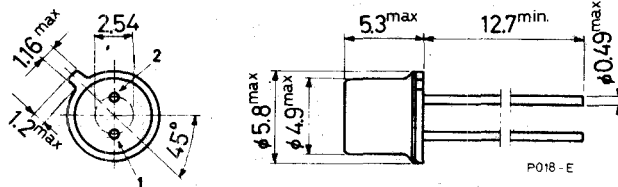

TAA 550 TBA 271

CONNECTION DIAGRAM (bottom view)

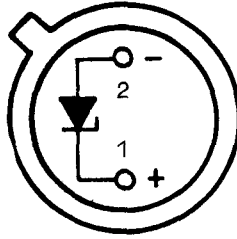

SS 0036

SCHEMATIC DIAGRAM

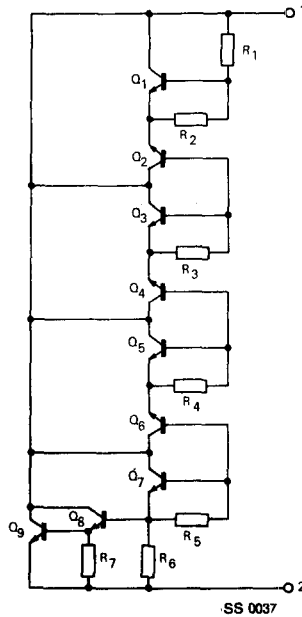

SS 0037

TEST CIRCUITS

Circuit No. 1 (for V_z measurement)

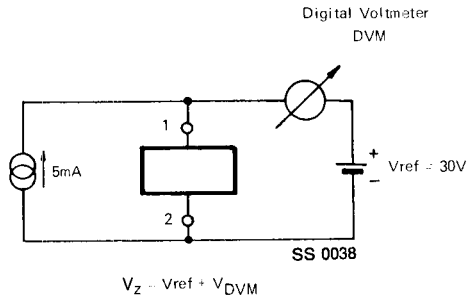

Circuit No. 2 (for r_z measurement)

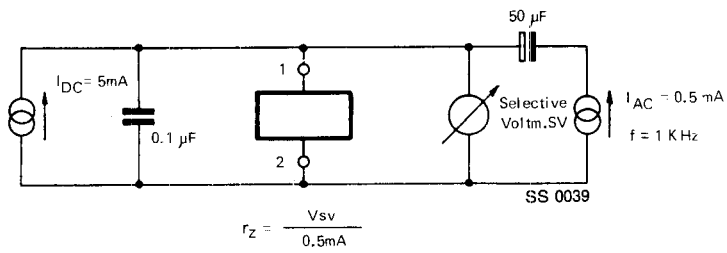

TAA 550 TBA 271

THERMAL DATA

$R_{th\ j-case}$	Thermal resistance junction-case	max	150	°C/W
$R_{th\ j-amb}$	Thermal resistance junction-ambient	max	400	°C/W

ELECTRICAL CHARACTERISTICS ($T_{amb} = 25\text{ °C}$ unless otherwise specified)

Parameter	Test conditions	Min.	Typ.	Max.	Unit
V_z Zener voltage	$I_z = 5\text{ mA}$ (circuit No. 1) for TAA 550 A/TBA 271 A for TAA 550 B/TBA 271 B for TAA 550 C/TBA 271 C	30	31	32.2	V
		32	33	34.2	V
		34	35	36	V
r_z Zener dynamic resistance	$I_z = 5\text{ mA}$ $I_{AC} = 0.5\text{ mA}$ $f = 1\text{ kHz}$ (circuit No. 2)		10	25	Ω
$\frac{\Delta V_z}{\Delta T_{amb}}$ Temperature coefficient	$I_z = 5\text{ mA}$ $\Delta T_{amb} = 0\text{ to }50\text{ °C}$	-3.2		+1.6	mV/°C

Fig. 1 - Power rating chart

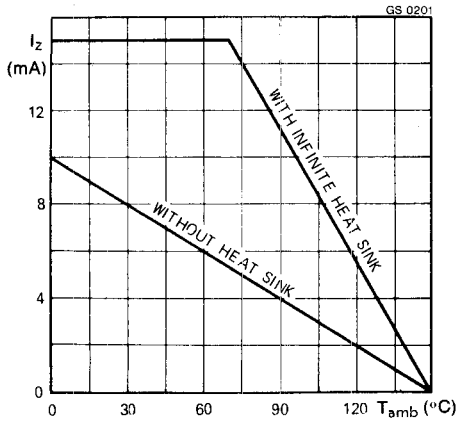

Fig. 2 - Typical zener dynamic resistance vs zener current

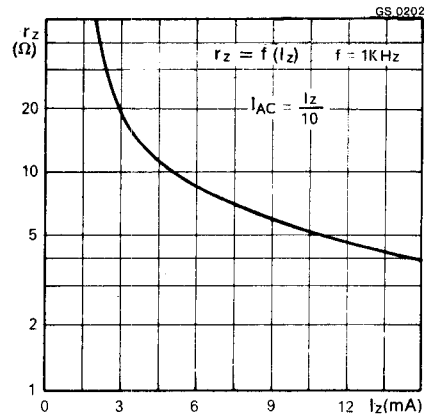

Fig. 3 - Typical temperature coefficient

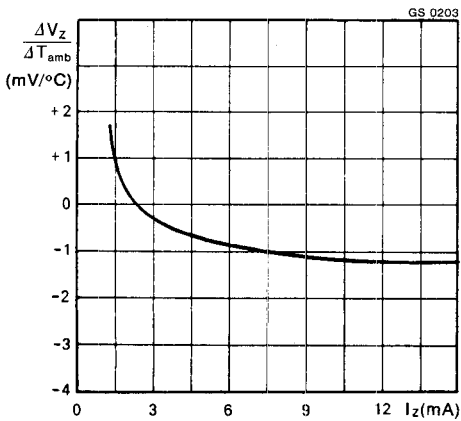
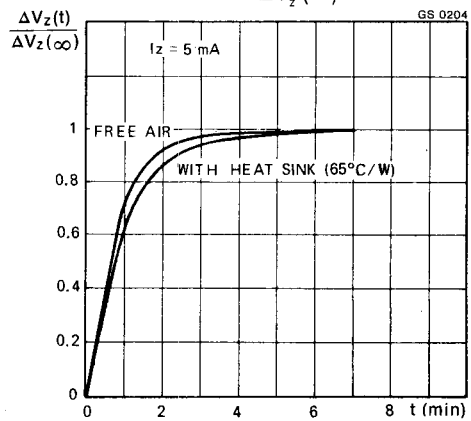

Fig. 4 - Typical $\frac{\Delta V_z(t)}{\Delta V_z(\infty)}$ vs time



TAA 550 TBA 271

TYPICAL APPLICATION

