



Document Title	HSD043I9W1-B Formal Specification	Page No.	1/26
Document No.		Revision	1.0

HannStar Product Specification **(Formal)**

4.3” Color TFT-LCD Module **Model : HSD043I9W1-B00**

Note:

1. Please contact HannStar Display Corp. before designing your product based on this module specification.
2. The information contained herein is presented merely to indicate the characteristics and performance of our products. No responsibility is assumed by HannStar for any intellectual property claims or other problems that may result from application based on the module described herein.



Document Title	HSD043I9W1-B Formal Specification	Page No.	2/26
Document No.		Revision	1.0

Record of Revisions

Rev.	Date	Sub-Model	Description of change
1.0		- -	Formal Product Specification was first released.



Document Title	HSD043I9W1-B Formal Specification	Page No.	3/26
Document No.		Revision	1.0

Contents

1.0	General description	p.4
2.0	Absolute maximum ratings	p.5
3.0	Optical characteristics	p.6
4.0	Block diagram	p.10
5.0	Interface pin connection	p.11
6.0	Electrical characteristics	p.12
7.0	Reliability test items.....	p.17
8.0	Outline dimension	p.18
9.0	Lot mark	p.19
10.0	Package specification	p.20
11.0	General precaution	p.21

Document Title	HSD043I9W1-B Formal Specification	Page No.	4/26
Document No.		Revision	1.0

1.0 GENERAL DESCRIPTION

1.1 Introduction

HannStar Display model HSD043I9W1-B is a color active matrix thin film transistor (TFT) liquid crystal display (LCD) that uses amorphous silicon TFT as a switching device. This model is composed of a TFT LCD panel, a driving circuit and a back light system. This TFT LCD has a 4.3 (16:9) inch diagonally measured active display area with WQVGA (480 horizontal by 272 vertical pixel) resolution.

1.2 Features

- 4.3 (16:9 diagonal) inch configuration
- 8-bit color depth with 256 gray-scale
- Parallel 24-bit or serial 8-bit RGB data input
- RoHS and Halogen-Free compliance

1.3 Applications

- Personal Navigation Device
- Multimedia applications and Others AV system

1.4 General information

Item	Specification	Unit	
Outline Dimension	105.5 x 67.2 x 2.9 (Typ.)	mm	
Display area	95.04 (H) x 53.856 (V)	mm	
Number of Pixel	480 RGB (H) x 272 (V)	pixels	
Pixel pitch	0.198 (H) x 0.198 (V)	mm	
Pixel arrangement	RGB Vertical stripe		
Display mode	Normally white		
Surface treatment	Antiglare, Hard-Coating (3H)		
Weight	43.5 (Typ.)	g	
Back-light	LED Side-light type		
Power Consumption	Logic System	0.09 (Max.)	W
	B/L System	0.462 (Max.)	W

1.5 Mechanical Information

Item	Min.	Typ.	Max.	Unit	
Module Size	Horizontal (H)	105.2	105.5	105.8	mm
	Vertical (V)	66.9	67.2	67.5	mm
	Depth (D)	—	2.9	3.2	mm
Weight (Without inverter)	—	43.5	—	g	

Document Title	HSD043I9W1-B Formal Specification	Page No.	5/26
Document No.		Revision	1.0

2.0 ABSOLUTE MAXIMUM RATINGS

2.1 Electrical Absolute Rating

2.1.1 TFT LCD Module

Item	Symbol	Min.	Max.	Unit	Note
Power supply voltage	VDD	-0.3	5.0	V	GND=0
Logic Signal Input Level	V _i	-0.3	5.0	V	

2.1.2 Back-Light Unit

Item	Symbol	Typ.	Max.	Unit	Note
LED current	I _L	20	—	mA	(1)(2)(3)
LED voltage	V _L	19.8	—	V	(1)(2)(3)

Note

- (1) Permanent damage may occur to the LCD module if beyond this specification. Functional operation should be restricted to the conditions described under normal operating conditions.
- (2) Ta =25±2°C
- (3) Test Condition: LED current 20 mA. The LED lifetime could be decreased if operating IL is larger than 20mA.

2.2 Environment Absolute Rating

Item	Symbol	Min.	Max.	Unit	Note
Operating Temperature	T _{opa}	-20	70	°C	
Storage Temperature	T _{stg}	-30	80	°C	

Document Title	HSD043I9W1-B Formal Specification	Page No.	6/26
Document No.		Revision	1.0

3.0 OPTICAL CHARACTERISTICS

3.1 Optical specification

Item		Symbol	Condition	Min.	Typ.	Max.	Unit	Note
Contrast		CR	Normal viewing angle	480	600	—		(1)(2)
Response time	Rising	T _R		—	3	6	msec	(1)(3)
	Falling	T _F		—	7	14		
White luminance (Center)		Y _L		180	220	—	cd/m ²	(1)(4)(7) (I _L =40mA)
Color chromaticity (CIE1931)	White	W _x		0.260	0.310	0.360		(1)(4)
		W _y	0.280	0.330	0.380			
Viewing angle	Hor.	θ _L	CR>10	65	75	—		
		θ _R		65	75	—		
	Ver.	θ _U		50	60	—		
		θ _D		60	70	—		
Brightness uniformity		B _{UNI}	θ=0	70	—	—	%	(5)(7)
Optima View Direction		6 O' clock						(6)

3.2 Measuring Condition

- Measuring surrounding: dark room
- LED current I_L: 20mA
- Ambient temperature: 25±2°C
- 15min. warm-up time.

3.3 Measuring Equipment

- FPM520 of Westar Display technologies, INC., which utilized SR-3 for Chromaticity and BM-5A for other optical characteristics.
- Measuring spot size: 20 ~ 21 m

Document Title	HSD043I9W1-B Formal Specification	Page No.	7/26
Document No.		Revision	1.0

Note (1) Definition of Viewing Angle:

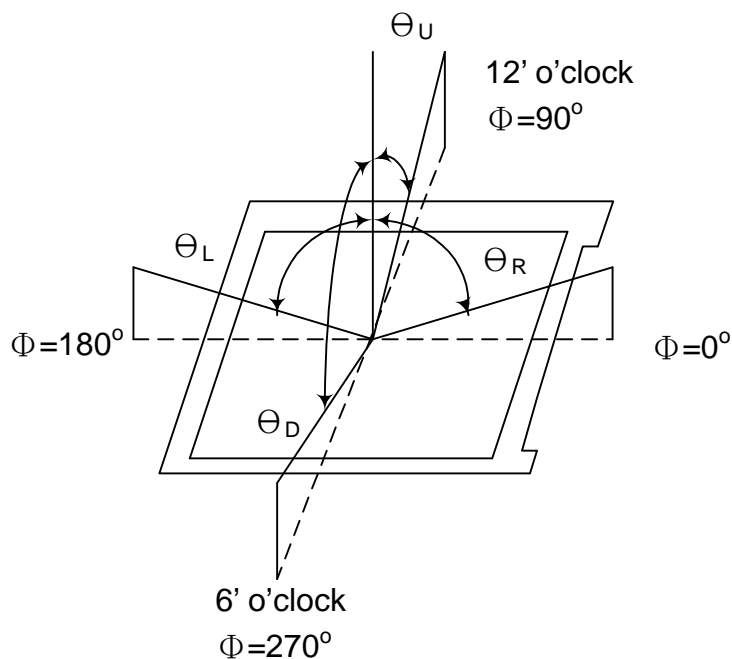

Note (2) Definition of Contrast Ratio (CR):
measured at the center point of panel

$$CR = \frac{\text{Luminance with all pixels white}}{\text{Luminance with all pixels black}}$$

Document Title	HSD043I9W1-B Formal Specification	Page No.	8/26
Document No.		Revision	1.0

Note (3) Definition of Response Time: Sum of T_R and T_F

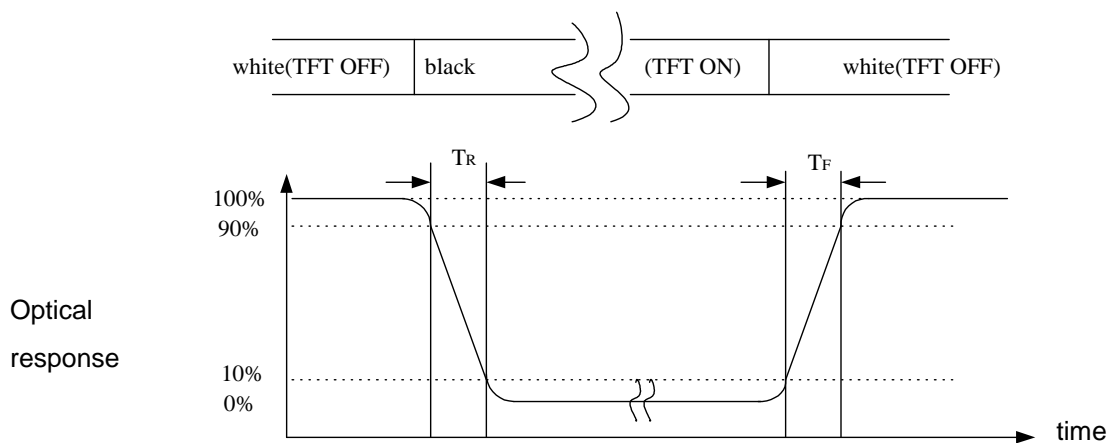

Note (4) Definition of optical measurement setup

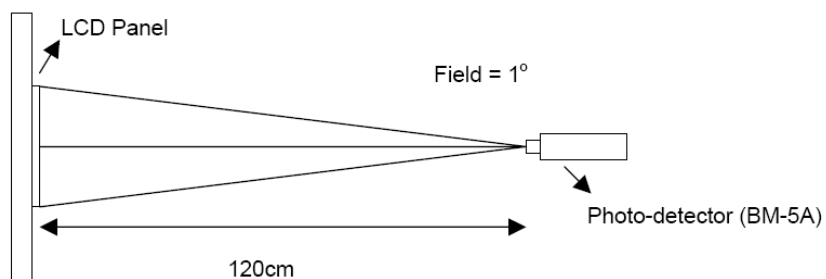

Document Title	HSD043I9W1-B Formal Specification	Page No.	9/26
Document No.		Revision	1.0

Note (5) Definition of brightness uniformity

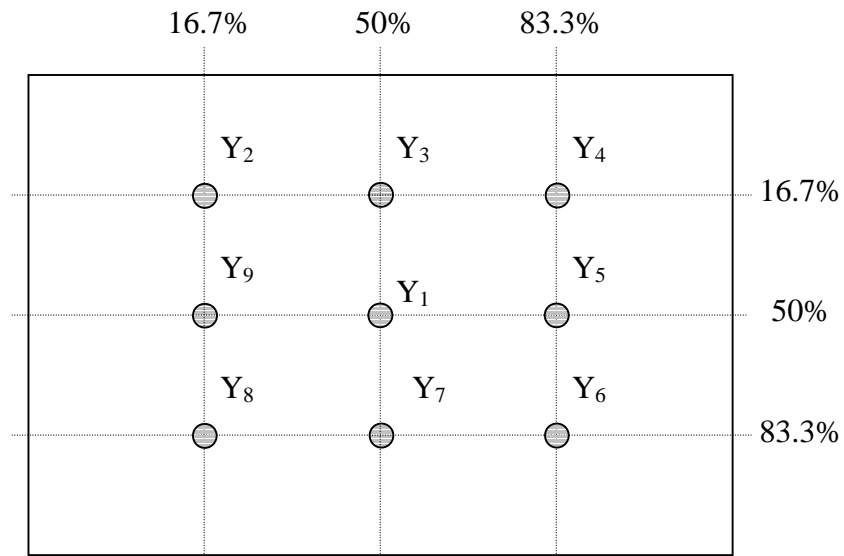

(Min Luminance of 9 points)

$$\text{Luminance uniformity} = \frac{\text{(Min Luminance of 9 points)}}{\text{(Max Luminance of 9 points)}} \times 100\%$$

Note (6) Rubbing Direction (The different Rubbing Direction will cause the different optima view direction.

Note (7) Measured at the brightness of the panel when all terminals of LCD panel are electrically open.

Document Title	HSD043I9W1-B Formal Specification	Page No.	10/26
Document No.		Revision	1.0

4.0 BLOCK DIAGRAM

4.1 TFT LCD Module

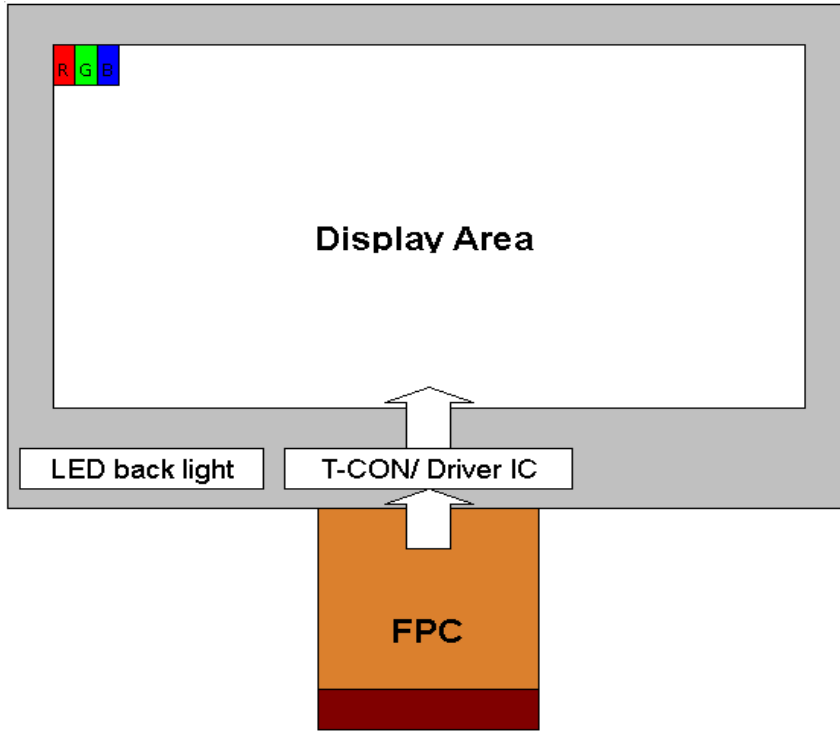

4.2 Pixel Format

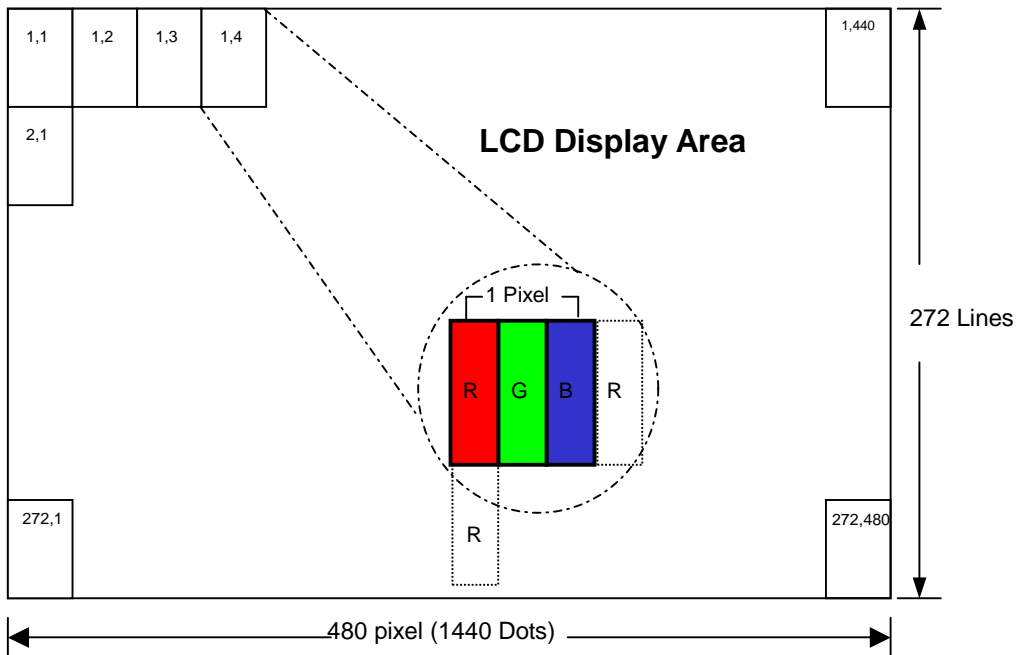

Document Title	HSD043I9W1-B Formal Specification	Page No.	11/26
Document No.		Revision	1.0

5.0 INPUT INTERFACE PIN ASSIGNMENT

FPC connector is used for electronics interface. The recommended model is FH19SC-40S-0.5SH (05) manufactured by HIROSE.

Pin No	Symbol	I/O	Function
1	V _{LED-}	P	Power for LED backlight cathode
2	V _{LED+}	P	Power for LED backlight anode
3	GND	P	Power ground
4	V _{DD}	P	Power voltage
5	R0	I	Red data (LSB)
6	R1	I	Red data
7	R2	I	Red data
8	R3	I	Red data
9	R4	I	Red data
10	R5	I	Red data
11	R6	I	Red data
12	R7	I	Red data (MSB)
13	G0	I	Green data (LSB)
14	G1	I	Green data
15	G2	I	Green data
16	G3	I	Green data
17	G4	I	Green data
18	G5	I	Green data
19	G6	I	Green data
20	G7	I	Green data (MSB)
21	B0	I	Blue data (LSB)
22	B1	I	Blue data
23	B2	I	Blue data
24	B3	I	Blue data
25	B4	I	Blue data
26	B5	I	Blue data
27	B6	I	Blue data
28	B7	I	Blue data (MSB)
29	GND	P	Power ground
30	DCLK	I	Pixel clock
31	DISP	I	Display on/ off
32	HSYNC	I	Horizontal sync signal
33	VSYNC	I	Vertical sync signal
34	DE	I	Data enable
35	PSSEL	I	Parallel 24-bit and Serial 8-bit data input selection. PSSEL="H", Parallel 24-bit RGB data input. (default) PSSEL="L", Serial 8-bit RGB data input.
36	GND	P	Power ground
37	X1	I/O	Right electrode - differential analog
38	Y1	I/O	Bottom electrode - differential analog
39	X2	I/O	Left electrode - differential analog
40	Y2	I/O	Top electrode - differential analog

I/O: I: input, O: output, P: power

Document Title	HSD043I9W1-B Formal Specification	Page No.	12/26
Document No.		Revision	1.0

6.0 ELECTRICAL CHARACTERISTICS

6.1 DC Electrical Characteristics

Parameters	Symbol	Min.	Typ.	Max.	Unit	Note
Supply voltage	V_{DD}	3.0	3.3	3.6	V	
Input signal voltage	V_{IH}	$0.7 V_{DD}$	—	V_{DD}	V	Note (1)
	V_{IL}	GND	—	$0.3 V_{DD}$	V	Note (1)
Current of power supply	I_{DD}	—	—	24.12	mA	$V_{DD} = 3.3V$

Note (1): HSYNC, VSYNC, DE, R/G/B Data

Note (2): GND = 0V

6.2 Back-Light Unit

The backlight system is an edge-lighting type with 6 LED.

The characteristics of the LED are shown in the following tables.

Parameters	Symbol	Min.	Typ.	Max.	Unit	Note
LED current	IL	—	20	—	mA	(2)
LED voltage	VL	—	19.8	—	V	
LED life time	Hr	10000	—	—	Hour	(1)(2)



LED Light Bar Circuit

Note (1) LED life time (Hr) can be defined as the time in which it continues to operate under the condition: $T_a=25\pm3\text{ }^\circ\text{C}$, typical IL value indicated in the above table until the brightness becomes less than 50%.

Note (2) The “LED life time” is defined as the module brightness decrease to 50% original brightness at $T_a=25\text{ }^\circ\text{C}$ and $I_L=20\text{mA}$. The LED lifetime could be decreased if operating I_L is larger than 20mA. The constant current driving method is suggested.

Document Title	HSD043I9W1-B Formal Specification	Page No.	13/26
Document No.		Revision	1.0

Note (3) Suggested schematic of LED backlight driver.

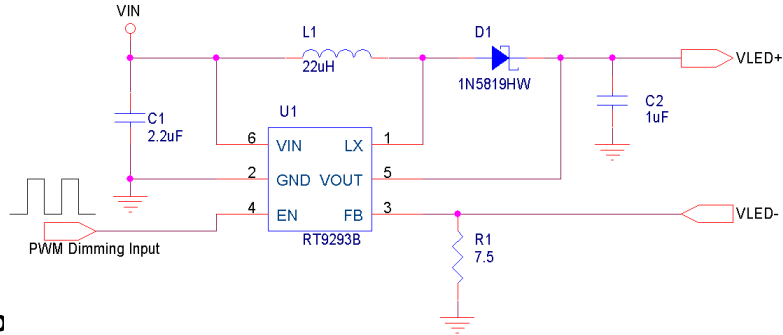

6.3 Data Inp

Parallel 24-bit RGB Input Timing Table

Parameters	Symbol	Min.	Typ.	Max.	Unit	Conditions
DCLK frequency	fclk	5	9	12	MHz	
VSYNC period time	Tv	277	288	400	Th	
VSYNC display area	Tvd	272			Th	
VSYNC back porch	Tvbp	3	8	31	Th	
VSYNC front porch	Tvfp	2	8	93	Th	
HSYNC period time	Th	520	525	800	DCLK	
HSYNC display area	Thd	480			DCLK	
HSYNC back porch	Thbp	36	40	255	DCLK	
HSYNC front porch	Thfp	4	5	65	DCLK	

Serial 8-bit RGB Input Timing Table

Parameters	Symbol	Min.	Typ.	Max.	Unit	Conditions
DCLK frequency	fclk	24	27	30	MHz	
VSYNC period time	Tv	277	288	400	Th	
VSYNC display area	Tvd	272			Th	
VSYNC back porch	Tvbp	3	8	31	Th	
VSYNC front porch	Tvfp	2	8	93	Th	
HSYNC period time	Th	1560	1716	1900	DCLK	
HSYNC display area	Thd	1440			DCLK	
HSYNC back porch	Thbp	108	120	255	DCLK	
HSYNC front porch	Thfp	12	168	205	DCLK	

Vertical Input Timing

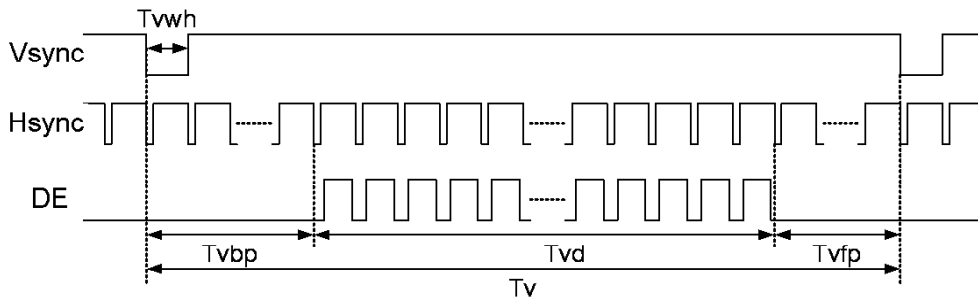

Document Title	HSD043I9W1-B Formal Specification	Page No.	14/26
Document No.		Revision	1.0

Parallel 24-bit RGB Mode Data Format (DE Mode)

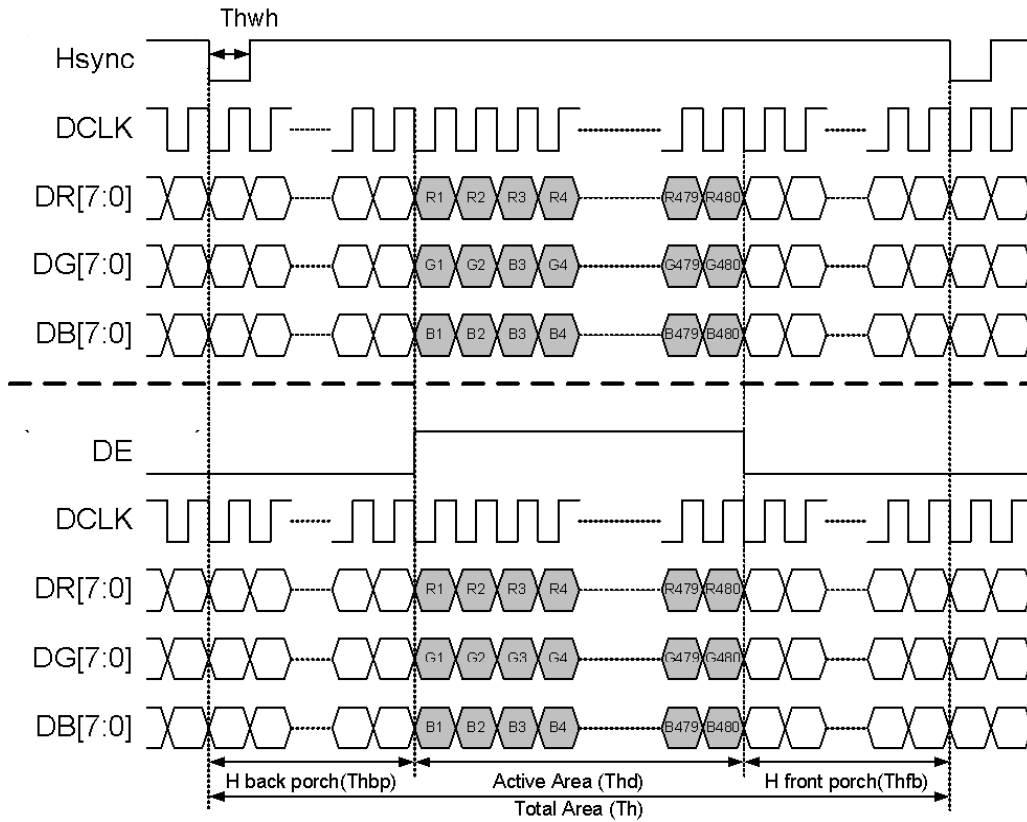

Serial 8-bit RGB Mode Data Format (DE Mode)

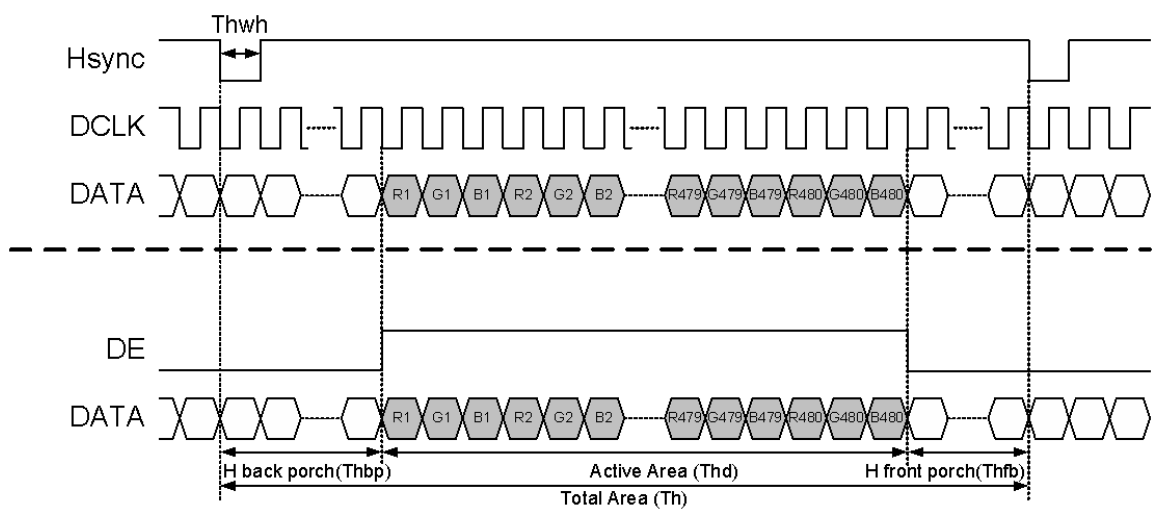

Document Title	HSD043I9W1-B Formal Specification	Page No.	15/26
Document No.		Revision	1.0

6.4 AC Electrical Characteristics

Parameters	Symbol	Min.	Typ.	Max.	Unit	Conditions
DCLK period time	Tclk	83.3	111.1	200	ns	Parallel 24-bit RGB mode
		33.3	37.0	41.7	ns	Serial 8-bit RGB mode
DCLK rising time	Trck	-	-	9	ns	
DCLK falling time	Tfck	-	-	9	ns	
DCLK pulse duty	Tcwh	40	50	60	%	
DE setup time	Tdesu	12	-	-	ns	
DE hold time	Tdehd	12	-	-	ns	
HSYNC pulse width	Thwh	1	-	-	DCLK	
HSYNC setup time	Thsu	12	-	-	ns	
HSYNC hold time	Thhd	12	-	-	ns	
VSYNC pulse width	Tvwh	1	-	-	Th	
VSYNC setup time	Tvsu	12	-	-	ns	
VSYNC hold time	Tvhd	12	-	-	ns	
Data setup time	Tdsu	12	-	-	ns	
Data hold time	Tdhd	12	-	-	ns	

Clock and Data Input Timing Diagram

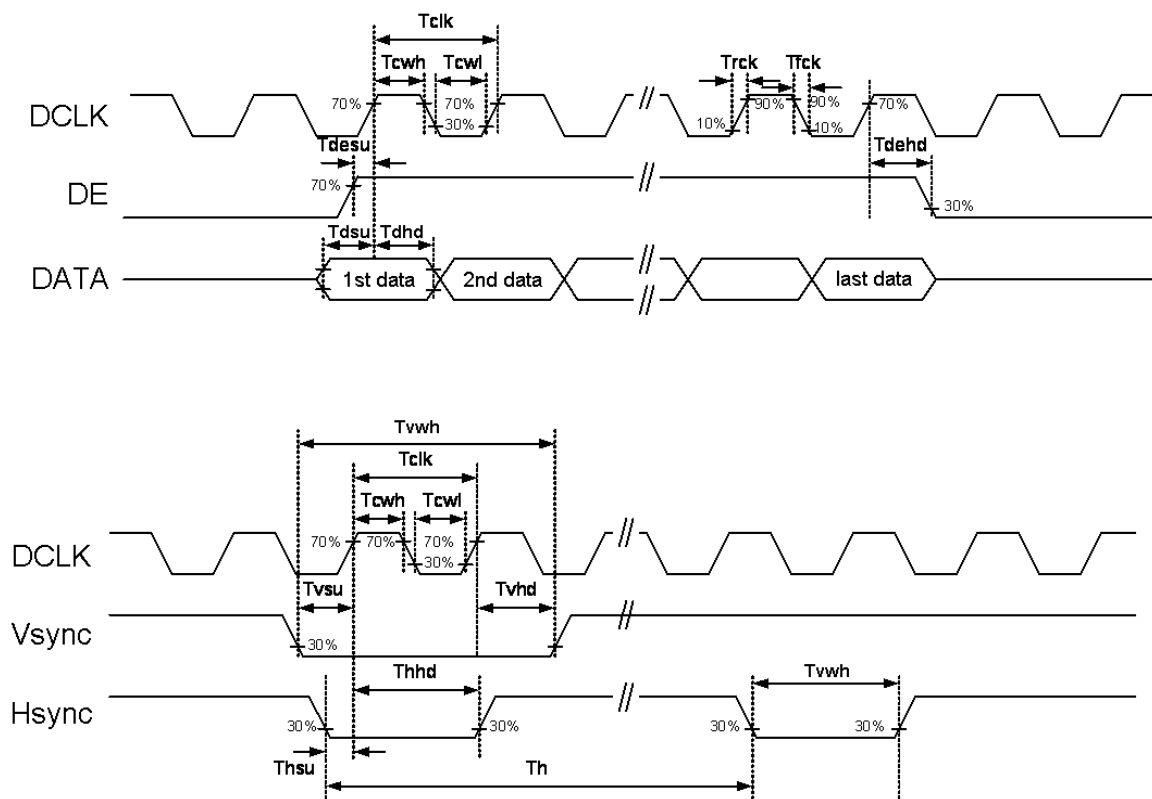

Document Title	HSD043I9W1-B Formal Specification	Page No.	16/26
Document No.		Revision	1.0

6.5 Power On/Off Sequence

Power On Sequence

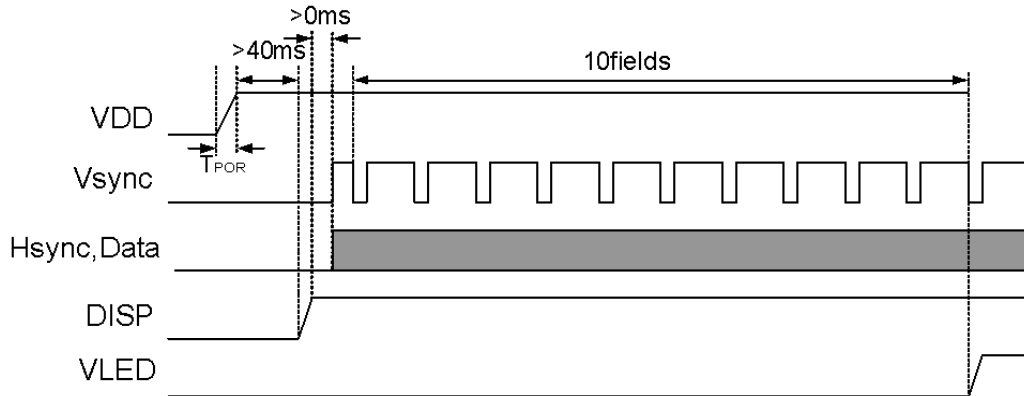

Power Off Sequence

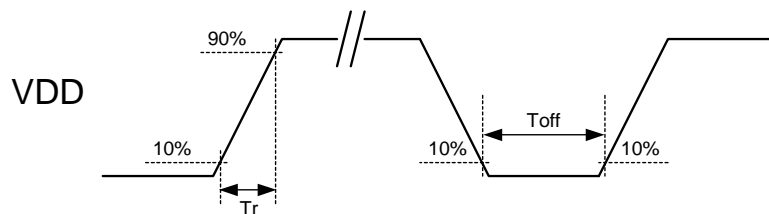
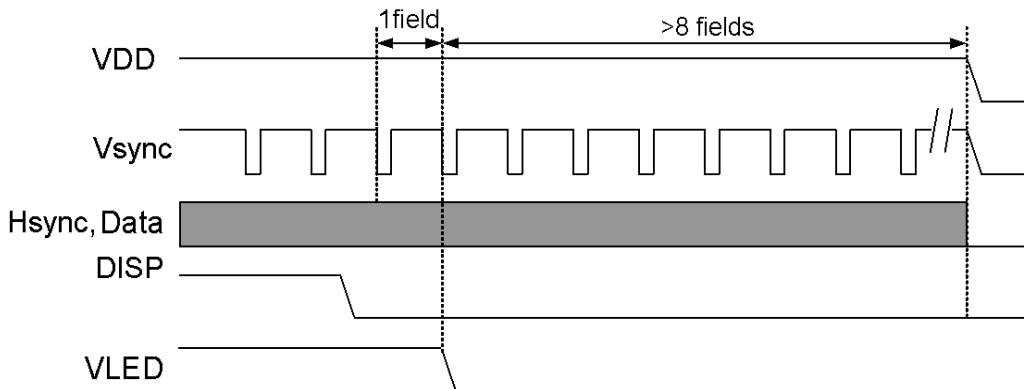

VDD power input timing

Notes:

- Data include R0~R7, G0~G7, B0~B7, HSD, VSD, DCLK, DE
- Power on sequence: VDD → DISP → Data → V_{LED}
- Power off sequence: DISP → V_{LED} → Data → VDD
- VDD power input timing: $0.5ms < T_r < 10ms$; $T_{off} > 500ms$

Document Title	HSD043I9W1-B Formal Specification	Page No.	17/26
Document No.		Revision	1.0

7.0 Reliability test items

No.	Item	Conditions	Remark
1	High Temperature Storage	Ta=+80°C, 240hrs	
2	Low Temperature Storage	Ta=-30°C, 240hrs	
3	High Temperature Operation	Ta=+70°C, 240hrs	
4	Low Temperature Operation	Ta=-20°C, 240hrs	
5	High Temperature and High Humidity (operation)	Ta=+60°C, 90%RH, 240hrs	
6	Thermal Cycling Test (non operation)	-30°C(30min) → +80°C(30min), 200cycles	
7	Electrostatic Discharge	±200V,200pF(0Ω) 1 time/each terminal	
8	Vibration	1.Random: 1.04Grms, 5~500Hz, X/Y/Z, 30min/each direction 2. Sine: Freq. Range: 8~33.3Hz Stoke: 1.3mm Sweep: 2.9G, 33.3~400Hz X/Z: 2hr, Y: 4hr, cyc: 15min	
9	Shock	100G, 6ms, ±X, ±Y, ±Z 3 time for each direction	JIS C7021, A-10 (Condition A)
10	Vibration (with carton)	Random: 0.015G ² /Hz, 5~200Hz -6dB/Octave, 200~400Hz XYZ each direction: 2hr	
11	Drop (with carton)	Height: 60cm 1 corner, 3 edges, 6 surfaces	JIS Z0202

Note: There is no display function NG issue occurred, all the cosmetic specification is judged before the reliability stress.

Document Title	HSD043I9W1-B Formal Specification	Page No.	18/26
Document No.		Revision	1.0

8.0 OUTLINE DIMENSION

8.1 Outline Dimension

Unit: mm

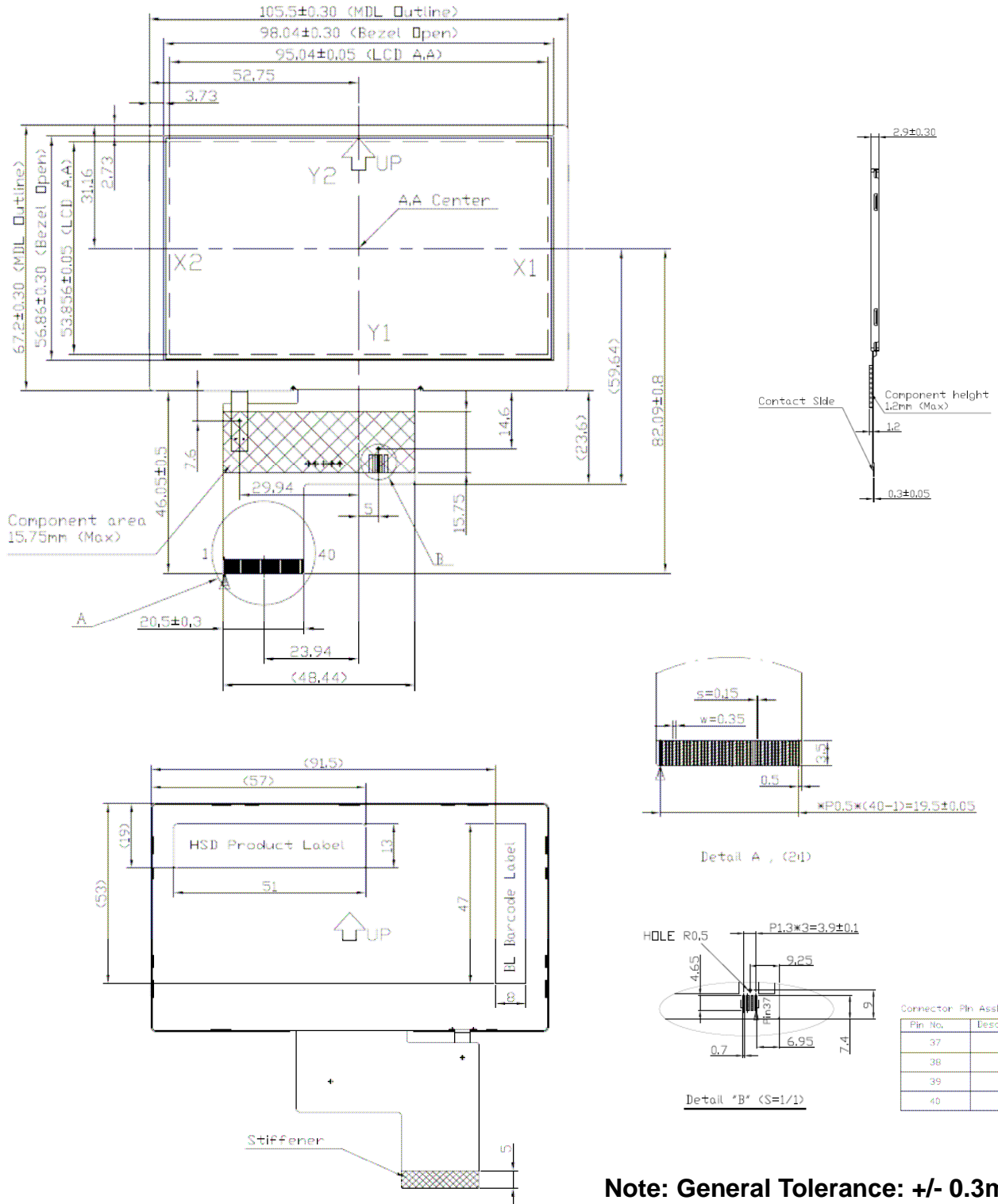

Note: General Tolerance: +/- 0.3mm

Document Title	HSD043I9W1-B Formal Specification	Page No.	19/26
Document No.		Revision	1.0

9.0 LOT MARK

9.1 Lot Mark

1	2	3	4	5	6	7	8	9	10	11	12	13	14	15
---	---	---	---	---	---	---	---	---	----	----	----	----	----	----

code 1,2,3,4,5,6: HannStar internal flow control code.

code 7: production location.

code 8: production year.

code 9: production month.

code 10,11,12,13,14,15: serial number.

Note (1) Production Year: Code 8 is defined by the last number of the year, for example

Year	2001	2002	2003	2004	2005	2006	2007	2008	2009	2010
Mark	1	2	3	4	5	6	7	8	9	0

Note (2) Production Month

Month	Jan.	Feb.	Mar.	Apr.	May.	Jun.	Jul.	Aug.	Sep.	Oct	Nov.	Dec.
Mark	1	2	3	4	5	6	7	8	9	A	B	C

9.2 Location of Lot Mark

- (1) Location: The label is attached to the backside of the LCD module. See Section 8.0 OUTLINE DIMENSION).
- (2) Detail of the Mark: as attached below.
- (3) This is subject to change without prior notice.

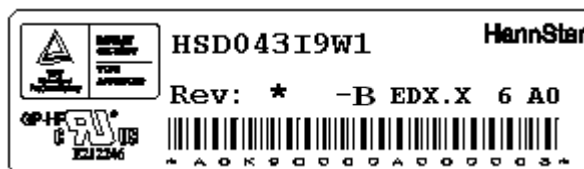

Document Title	HSD043I9W1-B Formal Specification	Page No.	20/26
Document No.		Revision	1.0

10.0 PACKAGE SPECIFICATION

10.1 Packing form

LCM Model	LCM Qty. in the box	Inner Box Size (mm)	Notice
HSD043I9W1-B	210	408 x 369 x 180	

10.2 Packing assembly drawings

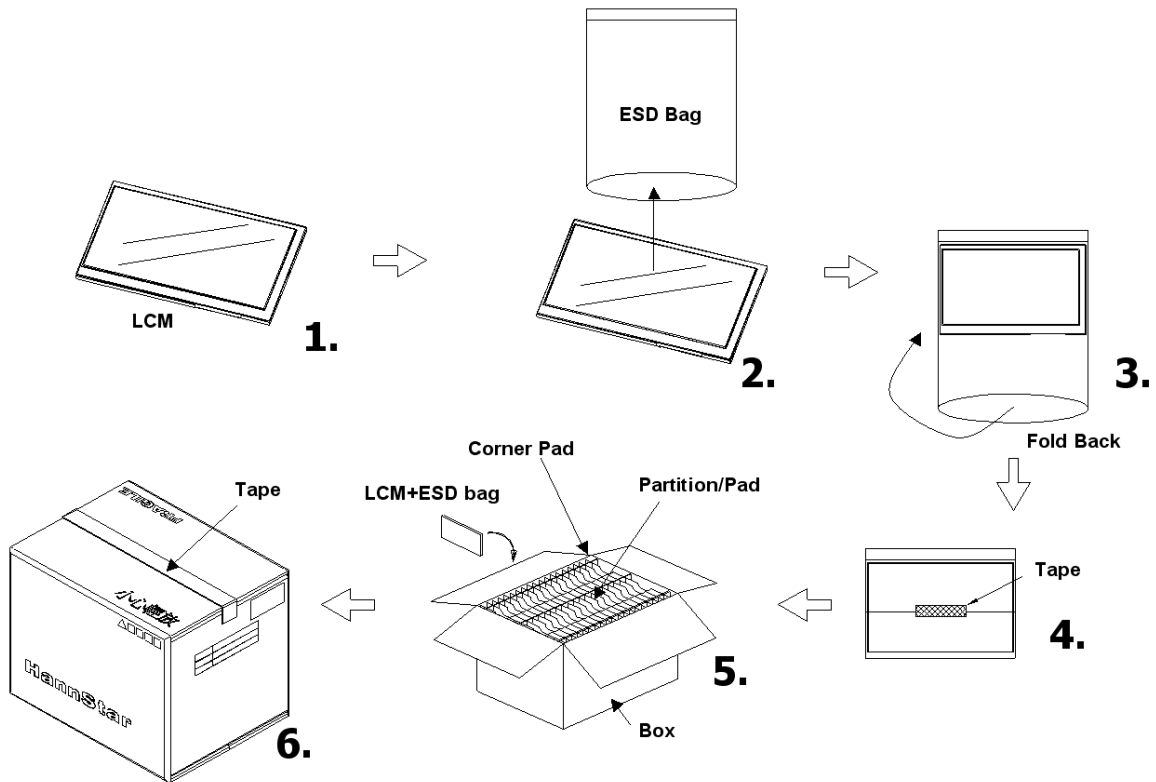

Items	Material	Notice
Box	Corrugated Paperboard	
Partition/Pad	Corrugated Paperboard	
Corner Pad	Corrugated Paperboard	
ESD bag	Corrugated Paperboard	

Document Title	HSD043I9W1-B Formal Specification	Page No.	21/26
Document No.		Revision	1.0

11.0 GENERAL PRECAUTION

11.1 Use Restriction

This product is not authorized for use in life supporting systems, aircraft navigation control systems, military systems and any other application where performance failure could be life-threatening or otherwise catastrophic.

11.2 Disassembling or Modification

Do not disassemble or modify the module. It may damage sensitive parts inside LCD module, and may cause scratches or dust on the display. HannStar does not warrant the module, if customers disassemble or modify the module.

11.3 Breakage of LCD Panel

11.3.1. If LCD panel is broken and liquid crystal spills out, do not ingest or inhale liquid crystal, and do not contact liquid crystal with skin.

11.3.2. If liquid crystal contacts mouth or eyes, rinse out with water immediately.

11.3.3. If liquid crystal contacts skin or cloths, wash it off immediately with alcohol and rinse thoroughly with water.

11.3.4. Handle carefully with chips of glass that may cause injury, when the glass is broken.

11.4 Electric Shock

11.4.1. Disconnect power supply before handling LCD module.

11.4.2. Do not pull or fold the LED cable.

11.4.3. Do not touch the parts inside LCD modules and the fluorescent LED's connector or cables in order to prevent electric shock.

11.5 Absolute Maximum Ratings and Power Protection Circuit

11.5.1. Do not exceed the absolute maximum rating values, such as the supply voltage variation, input voltage variation, variation in parts' parameters, environmental temperature, etc., otherwise LCD module may be damaged.

11.5.2. Please do not leave LCD module in the environment of high humidity and high temperature for a long time.

11.5.3. It's recommended to employ protection circuit for power supply.

11.6 Operation

11.6.1 Do not touch, push or rub the polarizer with anything harder than HB pencil lead.

11.6.2 Use fingerstalls of soft gloves in order to keep clean display quality, when persons handle the LCD module for incoming inspection or assembly.

11.6.3 When the surface is dusty, please wipe gently with absorbent cotton or other soft material.

Document Title	HSD043I9W1-B Formal Specification	Page No.	22/26
Document No.		Revision	1.0

11.6.4 Wipe off saliva or water drops as soon as possible. If saliva or water drops contact with polarizer for a long time, they may causes deformation or color fading.

11.6.5 When cleaning the adhesives, please use absorbent cotton wetted with a little petroleum benzine or other adequate solvent.

11.7 Mechanism

Please mount LCD module by using mounting holes arranged in four corners tightly.

11.8 Static Electricity

11.8.1 Protection film must remove very slowly from the surface of LCD module to prevent from electrostatic occurrence.

11.8.2. Because LCD module use CMOS-IC on circuit board and TFT-LCD panel, it is very weak to electrostatic discharge. Please be careful with electrostatic discharge. Persons who handle the module should be grounded through adequate methods.

11.9 Strong Light Exposure

The module shall not be exposed under strong light such as direct sunlight. Otherwise, display characteristics may be changed.

11.10 Disposal

When disposing LCD module, obey the local environmental regulations.