

332D

DC Voltage Standard

Instruction Manual

P/N 353292
April 1972
Rev. 1 3/75



WARRANTY

Notwithstanding any provision of any agreement the following warranty is exclusive:

The JOHN FLUKE MFG. CO., INC., warrants each instrument it manufactures to be free from defects in material and workmanship under normal use and service for the period of 1-year from date of purchase. This warranty extends only to the original purchaser. This warranty shall not apply to fuses, disposable batteries (rechargeable type batteries are warranted for 90-days), or any product or parts which have been subject to misuse, neglect, accident, or abnormal conditions of operations.

In the event of failure of a product covered by this warranty, John Fluke Mfg. Co., Inc., will repair and calibrate an instrument returned to an authorized Service Facility within 1 year of the original purchase; provided the warrantor's examination discloses to its satisfaction that the product was defective. The warrantor may, at its option, replace the product in lieu of repair. With regard to any instrument returned within 1 year of the original purchase, said repairs or replacement will be made without charge. If the failure has been caused by misuse, neglect, accident, or abnormal conditions of operations, repairs will be billed at a nominal cost. In such case, an estimate will be submitted before work is started, if requested.

THE FOREGOING WARRANTY IS IN LIEU OF ALL OTHER WARRANTIES, EXPRESS OR IMPLIED, INCLUDING BUT NOT LIMITED TO ANY IMPLIED WARRANTY OF MERCHANTABILITY, FITNESS, OR ADEQUACY FOR ANY PARTICULAR PURPOSE OR USE. JOHN FLUKE MFG. CO., INC., SHALL NOT BE LIABLE FOR ANY SPECIAL, INCIDENTAL, OR CONSEQUENTIAL DAMAGES, WHETHER IN CONTRACT, TORT, OR OTHERWISE.

If any failure occurs, the following steps should be taken:

1. Notify the JOHN FLUKE MFG. CO., INC., or nearest Service facility, giving full details of the difficulty, and include the model number, type number, and serial number. On receipt of this information, service data, or shipping instructions will be forwarded to you.
2. On receipt of the shipping instructions, forward the instrument, transportation prepaid. Repairs will be made at the Service Facility and the instrument returned, transportation prepaid.

SHIPPING TO MANUFACTURER FOR REPAIR OR ADJUSTMENT

All shipments of JOHN FLUKE MFG. CO., INC., instruments should be made via United Parcel Service or "Best Way" prepaid. The instrument should be shipped in the original packing carton; or if it is not available, use any suitable container that is rigid and of adequate size. If a substitute container is used, the instrument should be wrapped in paper and surrounded with at least four inches of excelsior or similar shock-absorbing material.

CLAIM FOR DAMAGE IN SHIPMENT TO ORIGINAL PURCHASER

The instrument should be thoroughly inspected immediately upon original delivery to purchaser. All material in the container should be checked against the enclosed packing list. The manufacturer will not be responsible for shortages against the packing sheet unless notified immediately. If the instrument is damaged in any way, a claim should be filed with the carrier immediately. (To obtain a quotation to repair shipment damage, contact the nearest Fluke Technical Center.) Final claim and negotiations with the carrier must be completed by the customer.

The JOHN FLUKE MFG. CO., INC., will be happy to answer all applications or use questions, which will enhance your use of this instrument. Please address your requests or correspondence to: JOHN FLUKE MFG. CO., INC., P.O. BOX C9090, EVERETT, WASHINGTON 98206, ATTN: Sales Dept. For European Customers: Fluke (Holland) B.V., P.O. Box 5053, 5004 EB, Tilburg, The Netherlands.

*For European customers, Air Freight prepaid.

John Fluke Mfg. Co., Inc., P.O. Box C9090, Everett, Washington 98206

Table of Contents

SECTION	TITLE	PAGE
1	INTRODUCTION AND SPECIFICATIONS	1-1
	1-1. Introduction	1-1
	1-6. Specifications	1-2
2	OPERATING INSTRUCTIONS	2-1
	2-1. Introduction	2-1
	2-3. Claim For Damage In Shipment	2-1
	2-5. Shipping Instructions	2-1
	2-7. Input Power	2-1
	2-9. Rack Mounting Procedures	2-1
	2-11. Controls, Terminals and Indicators	2-2
	2-13. Initial Operation	2-2
	2-14. General	2-2
	2-16. Voltage Trip Setting	2-2
	2-18. Current Limit Setting	2-5
	2-20. Sense Connections	2-5
	2-23. Guard Connection	2-5
	2-25. Operation	2-6
3	THEORY OF OPERATION	3-1
	3-1. Introduction	3-1
	3-3. Functional Description	3-1
	3-7. Circuit Descriptions	3-2
	3-8. Voltage Control Circuitry	3-2
	3-30. Pre-Regulation Circuitry	3-4
	3-38. Protection Circuitry	3-5
	3-44. Miscellaneous Circuitry	3-6

(Continued on page ii)

TABLE OF CONTENTS, *continued*

SECTION	TITLE	PAGE
4	MAINTENANCE	4-1
4-1.	Introduction	4-1
4-3.	Service Information	4-1
4-6.	General Maintenance	4-1
4-7.	Maintenance Access	4-1
4-10.	Unique Maintenance Procedures	4-2
4-14.	Fuse Replacement	4-2
4-16.	Lamp Replacement	4-2
4-18.	115/230V Conversion	4-2
4-20.	Performance Tests	4-2
4-21.	Introduction	4-2
4-27.	DC Output	4-4
4-32.	Meter and Protection Circuits	4-6
4-36.	Calibration	4-7
4-37.	Introduction	4-7
4-39.	Meter Mechanical Zero	4-7
4-41.	Auxiliary Circuits	4-7
4-48.	Voltage Standard Output	4-9
4-54.	Troubleshooting	4-14
4-57.	Resistance Measurements	4-14
4-59.	Standby Power	4-15
4-61.	Auxiliary Supply Voltages	4-15
4-63.	Unijunction Oscillator and Control Amplifier	4-16
4-67.	Pre-Regulator	4-17
4-69.	Series Pass Element	4-18
5	LISTS OF REPLACEABLE PARTS	5-1
	TABLE OF CONTENTS	5-1
5-1.	Introduction	5-2
5-4.	How to Obtain Parts	5-2
5-7.	Use Code Effectivity List	5-2
6	OPTION AND ACCESSORY INFORMATION	6-1
7	GENERAL INFORMATION	7-1
8	SCHEMATIC DIAGRAMS	8-1

List of Illustrations

FIGURE	TITLE	PAGE
1-1.	Model 332D Outline Drawing	1-1
2-1.	Chassis Slide Installation	2-2
2-2.	Controls, Terminals, and Indicators (Sheet 1 of 2)	2-3
2-2.	Controls, Terminals, and Indicators (Sheet 2 of 2)	2-4
2-3.	Nomograph of Voltage Drop Across Load Wires	2-6
2-4.	Guard Connection	2-7
3-1.	Voltage Control Circuitry	3-2
4-1.	115/230 VAC Conversion	4-3
4-2.	Location of Adjustments	4-8
4-3.	Connections for Sample String Linearization	4-12
4-4.	Connections for Range Calibration Checks	4-13
4-5.	Chopper Waveform	4-16
4-6.	Pre-Regulator Q1, Waveform on STDBY/RESET	4-17
4-7.	Pre-Regulator Q1, Waveform on OPR	4-17
4-8.	Waveforms Across Zener Diode	4-18

LIST OF ILLUSTRATIONS, *continued*

FIGURE	TITLE	PAGE
5-1.	DC Voltage Standard (Sheet 1 of 3)	5-4
5-1.	DC Voltage Standard (Sheet 2 of 3)	5-5
5-1.	DC Voltage Standard (Sheet 3 of 3)	5-6
5-2.	Capacitor Printed Circuit Assembly	5-10
5-3	Sample String Printed Circuit Assembly	5-13
5-4.	Capacitor Switch Printed Circuit Assembly	5-14
5-5.	Range Calibration Printed Circuit Assembly	5-15
5-6.	Main Mother Board Printed Circuit Assembly	5-16
5-7.	Reference Supply Printed Circuit Assembly	5-18
5-8.	Series Pass Driver Printed Circuit Assembly	5-20
5-9.	Differential Amplifier Printed Circuit Assembly	5-24
5-10.	Chopper Amplifier Printed Circuit Assembly	5-28
5-11.	Auxiliary Power Supply Printed Circuit Assembly	5-30
5-12.	Current Limiter Printed Circuit Assembly	5-32
5-13.	Time Delay Printed Circuit Assembly	5-35
5-14.	High Voltage Mother Board Printed Circuit Assembly	5-36
5-15.	Series Pass Element Printed Circuit Assembly	5-38
5-16.	Pre-Regulator Printed Circuit Assembly	5-42
8-1.	DC Voltage Standard (332B-1001)	8-3
8-2.	Support Module Assemblies (332B-1002)	8-9
8-3.	A2 Sample String (332B-1003)	8-13
8-4.	Power Distribution Assemblies (332B-1004)	8-15

List of Tables

TABLE	TITLE	PAGE
4-1.	Test and Calibration Equipment Required (Sheet 1 of 2)	4-3
4-1.	Test and Calibration Equipment Required (Sheet 2 of 2)	4-4
4-2.	Control Settings, Load Requirements, and Limits for Line Regulation	4-5
4-3.	Control Settings, Load Requirements, and Limits for Load Regulation	4-5
4-4.	Control Settings for V-I Monitor Test	4-6
4-5.	Control Settings for Voltage Trip Check	4-6
4-6.	Control Settings for Voltage Monitor Linearity Check	4-9
4-7.	Control Settings for Trip Range Check	4-9
4-8.	Sample String Pre-linearization	4-10
4-9.	Preliminary Range Calibration	4-10
4-10.	Control Settings for Voltage Monitor Linearity Check	4-11
4-11.	Control Settings for Trip Range Check	4-11
4-12.	Final Linearization of Deck C, B and A	4-12
4-13.	Final Range Calibration	4-13
4-14.	Control Settings and Tolerances for Calibration Check	4-14
4-15.	Reference and Auxiliary Voltages	4-16
4-16.	Series Pass Element Voltage Checks	4-18
7-1.	List of Abbreviations	7-1
7-2.	Federal Supply Codes for Manufacturers	7-3
7-3.	Fluke Technical Service Centers	7-10
7-4.	Sales Representatives - Domestic	7-11
7-5.	Sales Representatives - International	7-13

Section 1

Introduction & Specifications

1-1. INTRODUCTION

1-2. The Model 332D DC Voltage Standard provides dc voltages from 0 to 1111 volts with an accuracy of $\pm 0.001\%$. Output current is rated at 0 to 50 milliamperes. The output voltage is set by seven in-line decade switches. Separate terminals are provided for sensing the output voltage directly at the load, thereby eliminating errors due to voltage drop in connecting wires between the instrument and load.

1-3. Protection against possible equipment failures or operator errors, which might damage expensive instruments, are incorporated. The VOLTAGE TRIP and VERNIER controls provide a means of limiting the output volt-

age within the selected range. Should the output voltage exceed a preset limit, the OUTPUT terminals are de-energized. A current limiting circuit limits the available current to a level determined by the setting of the CURRENT LIMIT control.

1-4. The inner chassis and circuitry are surrounded by an isolation guard, which is also isolated from the front panel and the outside cover. When properly connected, the guard bypasses any circulating ground currents which may cause error.

1-5. Most of the instrument circuitry is mounted on modular plug-in cards. An extender card is provided as an accessory to aid in the maintenance and adjustment of the instrument.

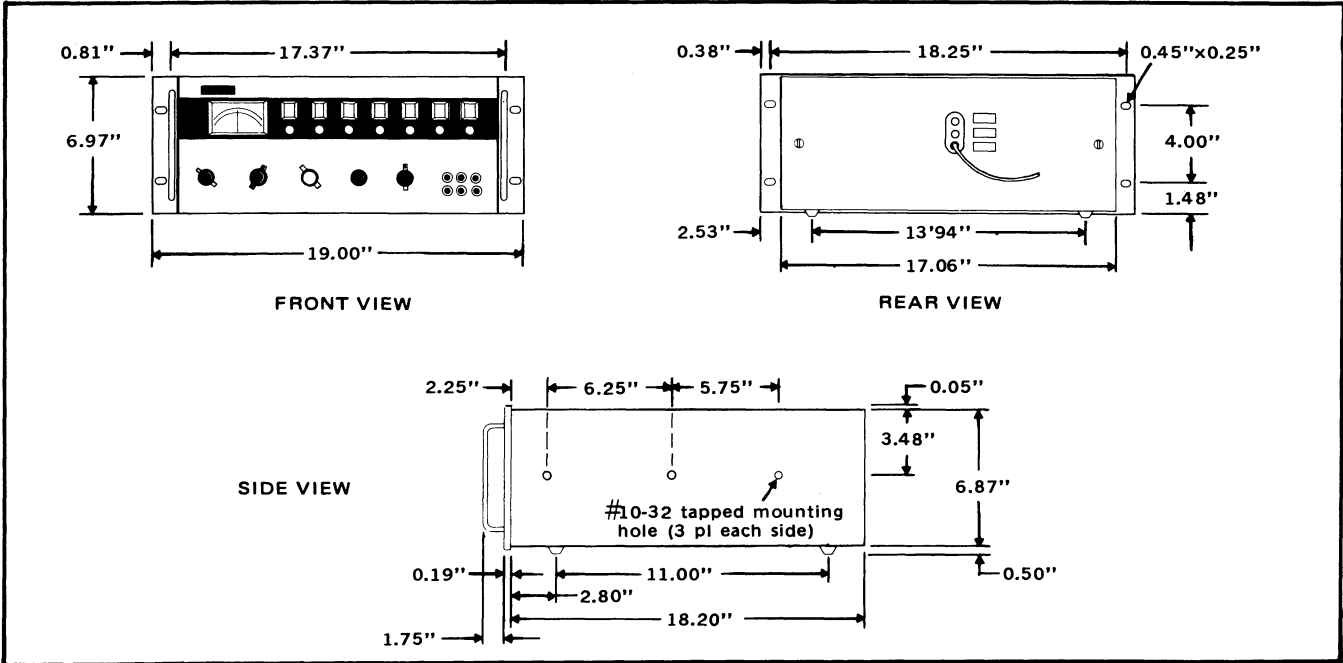

Figure 1-1. MODEL 332D OUTLINE DRAWING

1-6. SPECIFICATIONS

OUTPUT VOLTAGE: 0 to 1111.1110 VDC.

OUTPUT CURRENT: 0 to 50 milliamperes at any output voltage.

VOLTAGE RANGES: 10, 100, and 1000V ranges with outputs as follows:

- 0 to 11.111110 (1 uv steps)
- 0 to 111.111110 (10 uv steps)
- 0 to 1111.1110 (100 uv steps)

RESOLUTION: 0.1 ppm of range (1 uv maximum).

ACCURACY OF OUTPUT: (For 60 Days)

- 10V range - $\pm(0.001\%$ of setting + 10 uV)
- 100V range - $\pm(0.001\%$ of setting + 0.00002% of range)
- 1000V range - $\pm(0.0015\%$ of setting + 0.00002% of range)

NOTE: The above accuracies are absolute, relative to NBS standards, and include effects of stability, line regulation, load regulation, and calibration uncertainties under standard reference conditions of $23^{\circ}\text{C} \pm 1^{\circ}\text{C}$ and up to 70% relative humidity.

STABILITY OF OUTPUT: (At standard reference conditions described under ACCURACY OF OUTPUT).

10V Range

$\pm(5$ ppm of setting + 7 uV) per month

100V and 1000V Range

$\pm(5$ ppm of setting + 30 uV) per month

OVERCURRENT PROTECTION: Automatically limits output current at any preset level between 1 ma and 60 ma via continuously variable front panel control. Panel lamp illuminates during limiting. Normal operation restored upon removal of overload.

OVERVOLTAGE PROTECTION: Automatically disables output voltage if level exceeds setting of front panel control. Continuously variable from 10% to 110% of each range. Manual reset.

DESIGN: All solid-state throughout (no vacuum tubes).

RIPPLE AND NOISE (to 30 kHz):

- 10V range - less than 20 uv RMS
- 100V range - less than 30 uv RMS
- 1000V range - less than 40 uv RMS

OUTPUT RESISTANCE: Less than 0.0005 ohms or (0.0001E₀) ohms (whichever is greater) at DC.

SETTLING TIME: Typically, within 10 ppm of final output, less than 20 seconds after a range change.

LINE REGULATION: 0.0002% of setting or 10 uv for a 10% line voltage change from nominal.

LOAD REGULATION: 0.0002% of setting or 10 uv for a full load change.

COMMON MODE REJECTION: Better than 140 db from DC to 400 Hz, up to 700V RMS or 1000 VDC. (Output voltage changes less than 10^{-7} of the applied common mode voltage.)

ISOLATION: Either output terminal may be floated up to 1000 VDC from chassis ground.

TERMINAL CONFIGURATION:

Voltage output	- 2 terminals
Remote sense	- 2 terminals
Guard	- 1 terminal
Chassis	- 1 terminal

REMOTE SENSE: Separate terminals are provided for sensing the output voltage directly at the load, reducing errors due to voltage drop in connecting wires between the instrument and load.

METER (switch selectable): 0 - 1200 VDC
0 - 60 ma

OPERATING TEMPERATURE RANGE: 0°C to 50°C (see ACCURACY OF OUTPUT and TEMPERATURE COEFFICIENT OF OUTPUT).

STORAGE TEMPERATURE RANGE: -40°C to +65°C.

RELATIVE HUMIDITY: 0 to 70%.

SHOCK: Meets all test requirements of MIL-T-945A, rigidly mounted or rack-mounted with slides.

VIBRATION: Meets all test requirements of MIL-T-945A, rigidly mounted or rack-mounted with slides.

ALTITUDE: 10,000 ft. operating; 50,000 ft. non-operating.

FUSES: One power line fuse, one high voltage fuse.

INPUT POWER: 115/230 VAC $\pm 10\%$, 50 - 60 Hz, single phase. Approximately 130 VA fully loaded.

SIZE: 7" high x 19" wide x 18" behind panel.

WEIGHT: 60 lbs.

MOUNTING: Standard EIA relay rack (tapped for attachment of slides); resilient feet provided for bench use.



static awareness



A Message From
John Fluke Mfg. Co., Inc.

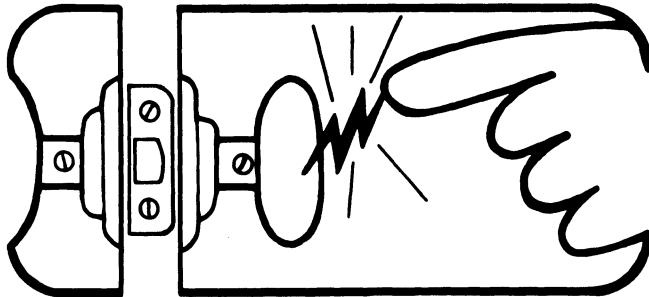

Some semiconductors and custom IC's can be damaged by electrostatic discharge during handling. This notice explains how you can minimize the chances of destroying such devices by:

1. Knowing that there is a problem.
2. Learning the guidelines for handling them.
3. Using the procedures, and packaging and bench techniques that are recommended.

The Static Sensitive (S.S.) devices are identified in the Fluke technical manual parts list with the symbol "⊗"

The following practices should be followed to minimize damage to S.S. devices.

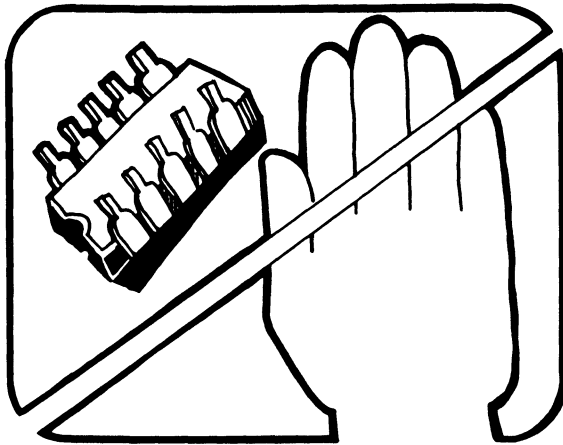

1. MINIMIZE HANDLING

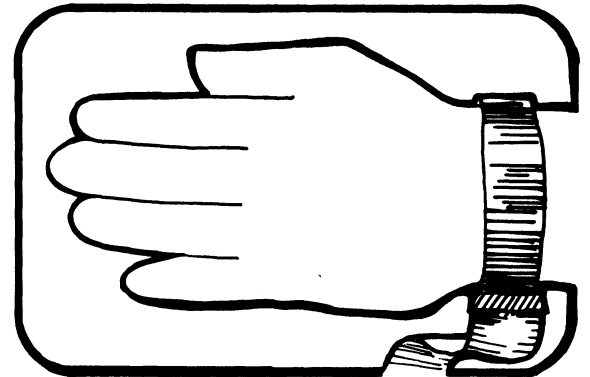

3. DISCHARGE PERSONAL STATIC BEFORE HANDLING DEVICES

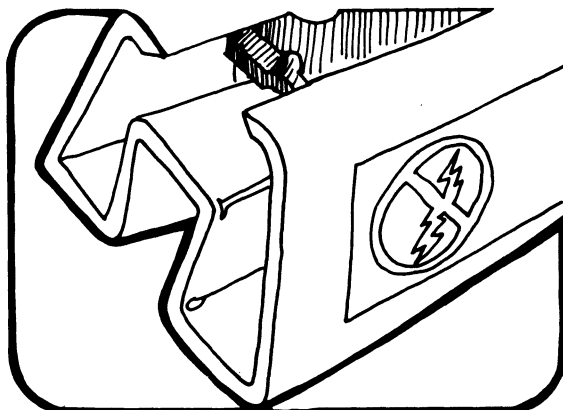

2. KEEP PARTS IN ORIGINAL CONTAINERS UNTIL READY FOR USE.

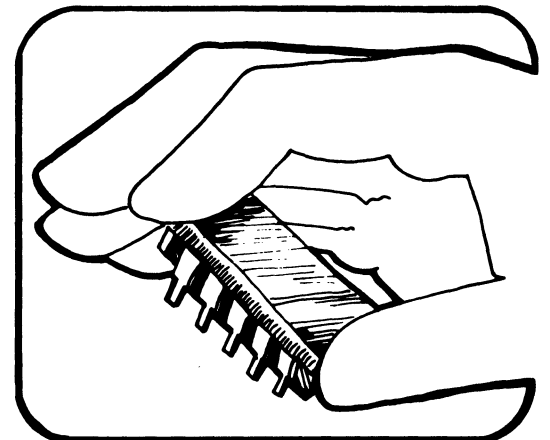

4. HANDLE S.S. DEVICES BY THE BODY

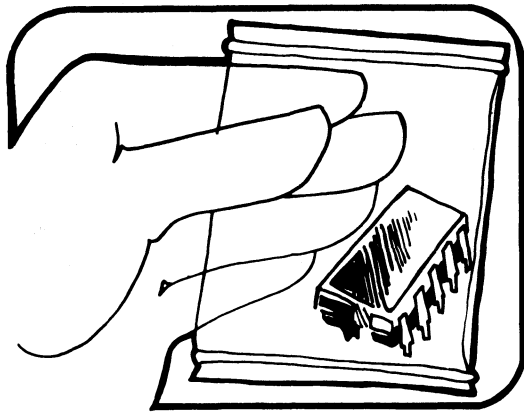

5. USE ANTI-STATIC CONTAINERS FOR HANDLING AND TRANSPORT

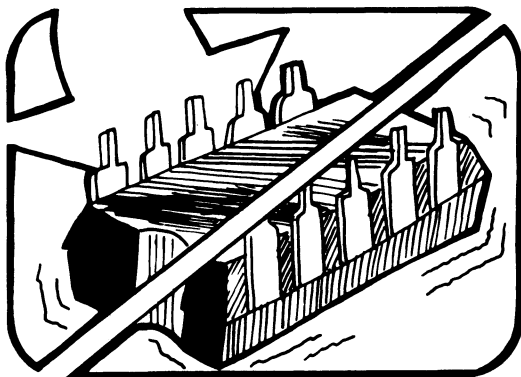

6. DO NOT SLIDE S.S. DEVICES OVER ANY SURFACE

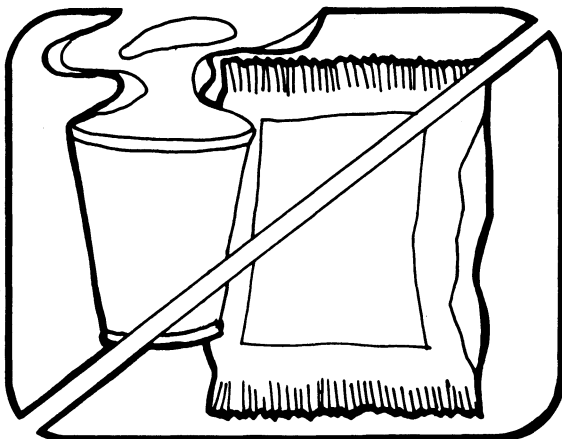

7. AVOID PLASTIC, VINYL AND STYROFOAM® IN WORK AREA

PORTIONS REPRINTED
WITH PERMISSION FROM TEKTRONIX, INC.
AND GENERAL DYNAMICS, POMONA DIV.

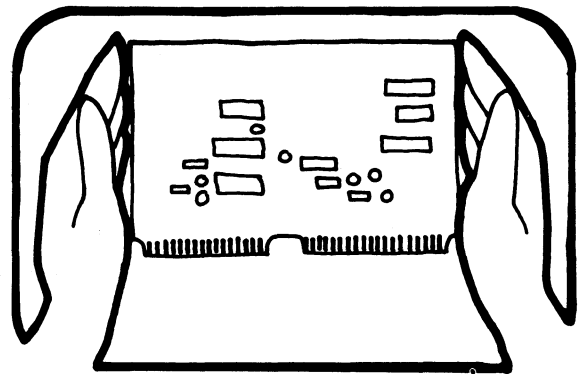

8. WHEN REMOVING PLUG-IN ASSEMBLIES, HANDLE ONLY BY NON-CONDUCTIVE EDGES AND NEVER TOUCH OPEN EDGE CONNECTOR EXCEPT AT STATIC-FREE WORK STATION. PLACING SHORTING STRIPS ON EDGE CONNECTOR USUALLY PROVIDES COMPLETE PROTECTION TO INSTALLED SS DEVICES.

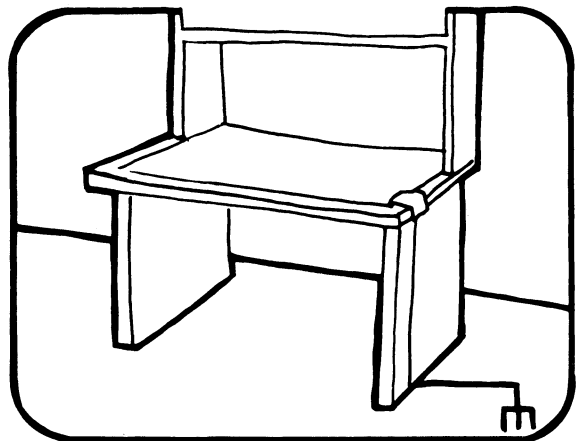

9. HANDLE S.S. DEVICES ONLY AT A STATIC-FREE WORK STATION
10. ONLY ANTI-STATIC TYPE SOLDER-SUCKERS SHOULD BE USED.
11. ONLY GROUNDED TIP SOLDERING IRONS SHOULD BE USED.

Anti-static bags, for storing S.S. devices or pcbs with these devices on them, can be ordered from the John Fluke Mfg. Co., Inc.. See section 5 in any Fluke technical manual for ordering instructions. Use the following part numbers when ordering these special bags.

John Fluke Part No.	Description
453522	6" X 8" Bag
453530	8" X 12" Bag
453548	16" X 24" Bag
454025	12" X 15" Bag
Pink Poly Sheet	Wrist Strap
30"x60"x60 Mil	P/N TL6-60
P/N RC-AS-1200	\$7.00
\$20.00	

Section 2

Operating Instructions

2-1. INTRODUCTION

2-2. This section of the manual contains information essential to the correct operation and performance of the Model 332D DC Voltage Standard. It is recommended that the contents of this section be thoroughly read and understood before attempting to operate the instrument. Should any difficulties be encountered during the operation of your instrument, please feel free to contact the nearest John Fluke Sales Representative or the John Fluke Mfg. Co., Inc., Box 43210, Mountlake Terrace, Washington, 98043. A complete list of Sales Representatives is located in Section 7 of this manual.

2-3. CLAIM FOR DAMAGE IN SHIPMENT

2-4. The Instrument should be thoroughly inspected immediately upon receipt. All material in the container should be checked against the enclosed packing list. The manufacturer will not be responsible for shortages against the packing sheet unless notified immediately. If the instrument fails to operate properly, or is damaged in any way, a claim should be filed with the carrier. A full report of the damage should be obtained by the claim agent, and this report should be forwarded to the John Fluke representative. Upon receipt of this report you will be advised of the disposition of the equipment for repair or replacement. Include the model number, type number, and serial number when referring to this instrument for any reason.

2-5. SHIPPING INSTRUCTIONS

2-6. All John Fluke Mfg. Co., Inc. instruments should be shipped prepaid in the original packing carton. Upon request, a new carton can be obtained from the John Fluke Mfg. Co., Inc. Please include the instrument model number when requesting a new container.

2-7. INPUT POWER

2-8. The power transformer has dual primary windings. Normally, these primary windings are connected in parallel for 115 volt operation. Upon request, the primary windings are connected in series at the factory for 230 volt operation. Should it become desirable to convert the instrument from one type of power line operation to the other, refer to paragraph 4-18 in Section 4.

2-9. RACK MOUNTING PROCEDURES

2-10. The Model 332D is supplied with rubber nonskid feet. A rack-slide kit (FLUKE MEE-8088) is available for installation of the instrument in a standard 19-inch rack. In order to rack mount the instrument refer to figure 2-1 and perform the following steps:

- a. Attach the chassis section (A) to the side panels with the screws (B) provided in the kit.
- b. Install the cabinet sections (D) and center sections (C) into equipment rack. The extension angle

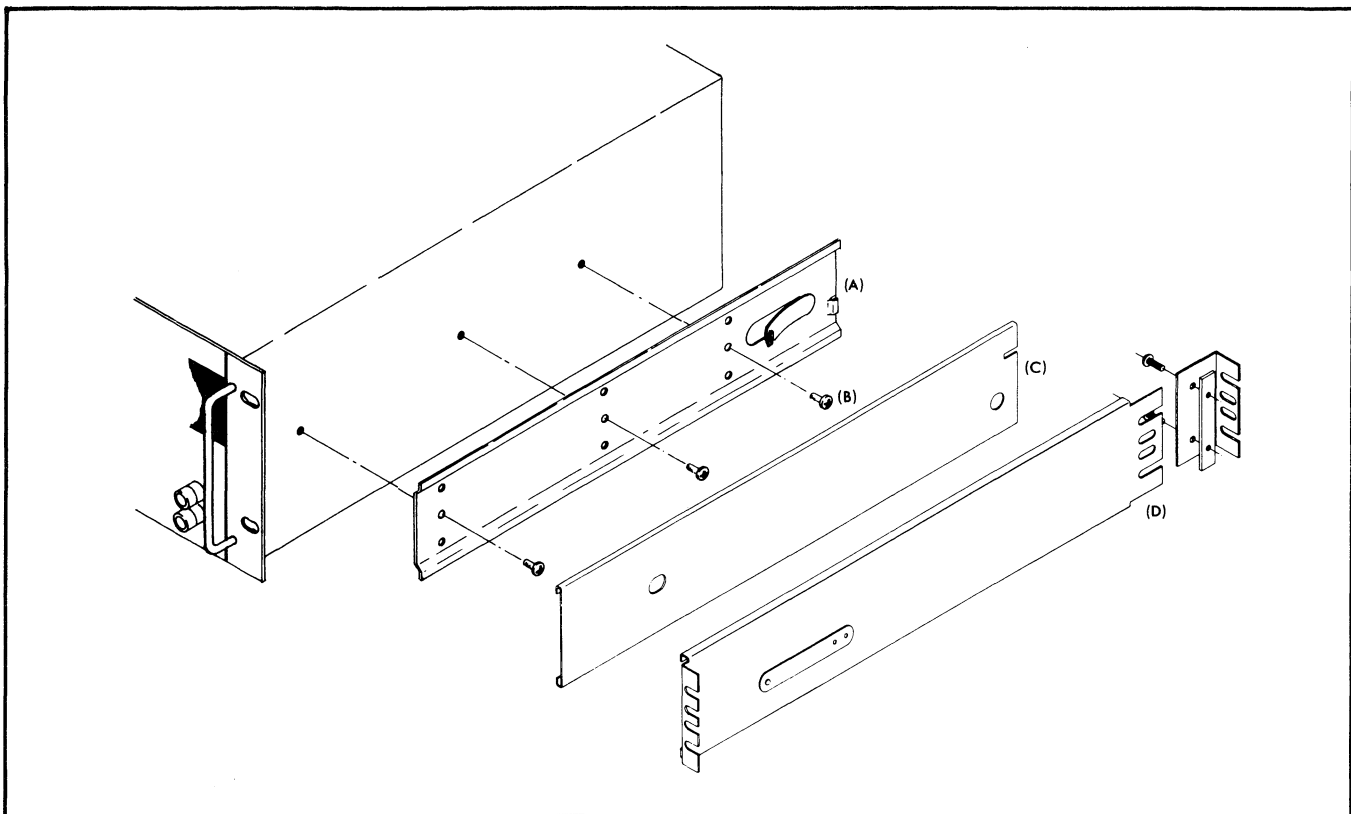

Figure 2-1. CHASSIS SLIDE INSTALLATION

brackets, which are part of section (D), are mounted at the rear of the cabinet.

- c. Slide the center sections (C) toward the front of the cabinet until they lock in place.
- d. Depress the spring locks on the chassis sections (A) and insert the instrument between the extended center sections (C) on the cabinet.
- e. Slide the instrument completely into the equipment rack and secure it in place with fasteners through the front panel.

2-11. CONTROLS, TERMINALS AND INDICATORS

2-12. The name and function of the front and rear panel controls, terminals, and indicators are illustrated and described in Figure 2-2. The numbers at the tails of the arrow callouts correspond to the reference numbers in the chart.

2-13. INITIAL OPERATION

2-14. General

2-15. Before operating the instrument, some prelim-

inary settings and connections should be considered. The use of these settings and connections depends upon the degree of equipment safety and accuracy required. The following paragraphs discuss the merits and procedures for each of the settings and connections.

2-16. Voltage Trip Setting

2-17. The VOLTAGE TRIP switch and VERNIER control provide protection to external equipment by limiting the maximum allowable output voltage to the external load. The range of voltage limiting is selected with the VOLTAGE TRIP switch. Refinement of the value of the voltage to be limited is accomplished with the VERNIER control. If no degree of limiting is required within the ranges of the instrument, set the VOLTAGE TRIP switch to 1000 and the VERNIER fully clockwise. Should some degree of limiting be desirable, proceed as follows:

- a. Without any load connected to the OUTPUT terminals and the POWER switch in the STDBY/RESET position, set the front-panel controls as follows:

RANGE	As desired
VOLTAGE TRIP	To the lowest range that overlaps the desired trip voltage

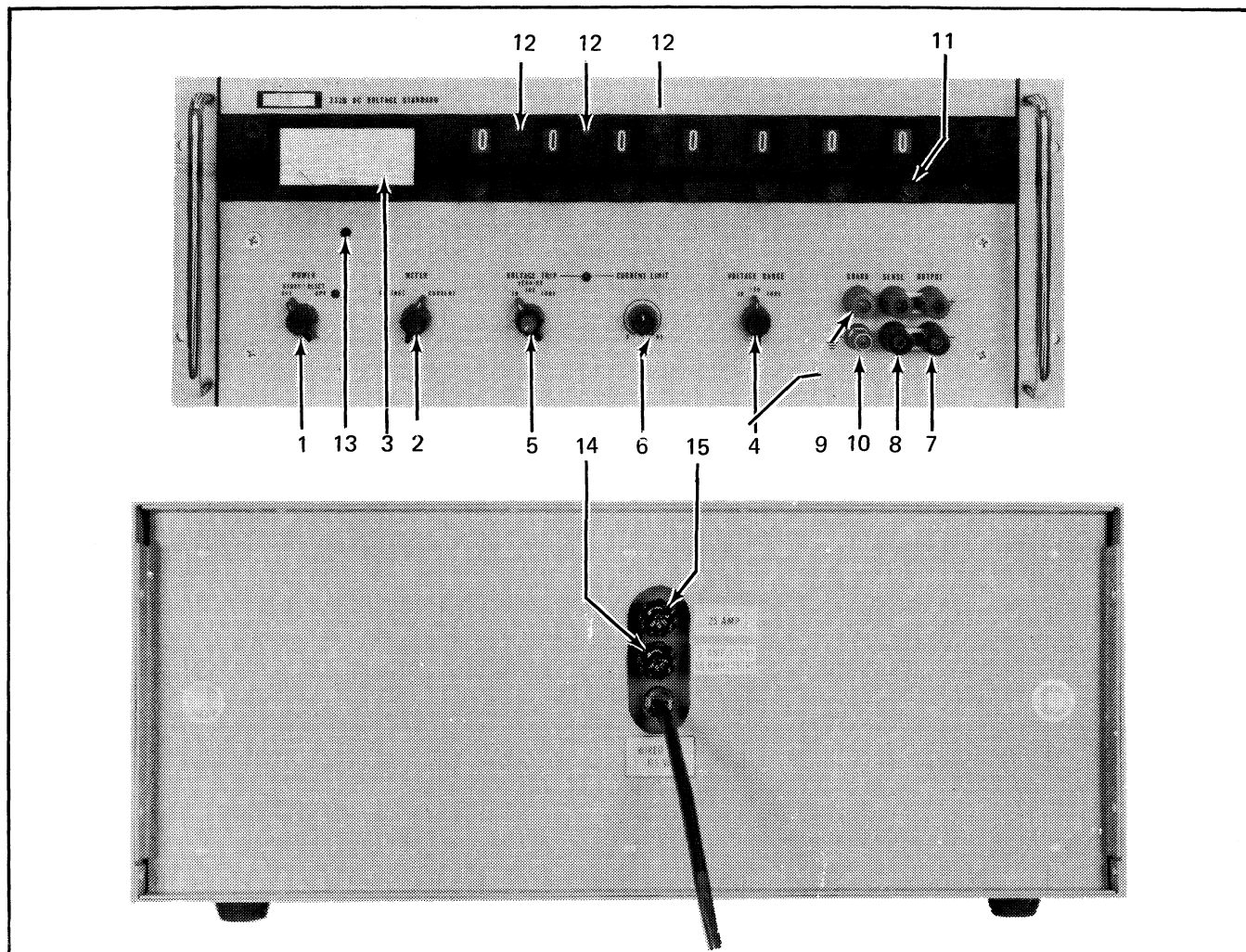

REF. NO.	NAME	FUNCTION
1	POWER switch	Applies line power to the auxiliary power supplies within the instrument, when in the STDBY/RESET position. The instrument is completely energized when the POWER switch is in the OPR position and the red indicator lamp near the switch is illuminated.
2	METER Switch	Selects meter indication of either output voltage or output current.
3	Meter	Indicates either output voltage or output current depending on the position of the METER switch. The meter voltage range depends on the setting of the VOLTAGE RANGE switch. The current range is 0 to 60 milliamperes.
4	VOLTAGE RANGE Switch	Selects the output voltage range of 10, 100, or 1000 volts, and changes the meter to a corresponding range.

Figure 2-2. CONTROLS, TERMINALS, AND INDICATORS (Sheet 1 of 2)

REF. NO.	NAME	FUNCTION
5	VOLTAGE TRIP Switch and VERNIER Control	The VOLTAGE TRIP switch provides a means of limiting the output voltage in three ranges (10, 100, and 1000 volts) independent of the VOLTAGE RANGE switch. The VERNIER control varies the amount of limiting within the ranges of the VOLTAGE TRIP switch. When an over-voltage condition exists, the red indicator lamp near the VOLTAGE TRIP switch illuminates and the red lamp near the POWER switch is extinguished.
6	CURRENT LIMIT control	Provides a means of setting a limit on the magnitude of the output current within a range to 0 to 60 milliamperes. An over-current condition is signified when the indicator lamp, near the CURRENT LIMIT control, illuminates.
7	OUTPUT Terminals	Provides a convenient means of connecting the load to the output circuit.
8	SENSE Terminals	Allows the regulating circuitry to be connected to the OUTPUT terminals (7) or directly to the load for optimum regulation.
9	GUARD Terminal	When properly connected, provides a means of eliminating circulating ground currents through the load.
10		Power line ground.
11	Readout Dials	Select and indicate the output voltage. The recessed numbers directly above each dial provide in-line readout of the output voltage. When a dial is set to "X" (10), it represents 0 with a 1 carry-over to the digit to the immediate left. For example: 10. X X X X X X represents 11.111110 volts.
12	Decimal Lamps	These lamps indicate the proper decimal point setting when illuminated and are controlled by the RANGE switch.
13	Mechanical Zero adjust	Provides a means of setting the meter mechanical zero. Adjustment should be made after the instrument has been completely de-energized for at least 3 minutes.
14	Fuse, line	A 3 ampere slow-blow fuse for 115 volt power line operation. Use a 1½ ampere slow-blow fuse for instruments converted to 230 volt power line operation.
15	Fuse, high voltage	A ¼ ampere slow-blow fuse electrically located at the output of the high voltage rectifier circuit.

Figure 2-2. CONTROLS, TERMINALS, AND INDICATORS (Sheet 2 of 2)

VERNIER	Fully cw
CURRENT LIMIT	As desired
METER	Voltage
Readout Dials	Desired trip voltage

- b. Set the POWER switch from the STDBY/RESET position to OPR.
- c. Slowly rotate the VERNIER control counter-clockwise until the indicator lamp near the VOLTAGE TRIP switch illuminates and the red lamp near the POWER switch is extinguished. The voltage trip is now set to the value indicated on the readout dials and the instrument is tripped to the STDBY mode.
- d. To reset the instrument, set the readout dials to a value less than the trip voltage and place the POWER switch in the STDBY/RESET position, then to OPR.

2-18. Current Limit Setting

2-19. The CURRENT LIMIT control provides a means of limiting the amount of output current. If no limiting within the current range of the instrument is desirable, set the CURRENT LIMIT control to the fully clockwise position (60). Should some degree of current limiting be desirable, proceed as follows:

- a. With the POWER switch in the STDBY/RESET position, set the front panel controls as follows:

RANGE	As desired
VOLTAGE TRIP and VERNIER	As desired
VOLTAGE CURRENT LIMIT	Fully clockwise
METER	Current
Readout Dials	1 volt

- b. Place a short across the OUTPUT terminals.
- c. Set the POWER switch to the OPR position.
- d. Adjust the CURRENT LIMIT control until the current indicated on the meter is the value of the desired limiting current.
- e. Place the POWER switch in the STDBY/RESET position. Remove the short. Current limiting is now set to the desired value for any output voltage.

2-20. Sense Connections

2-21. When a load is connected, there may be an appreciable voltage drop between the instrument and the load,

depending on the length and gauge of the connecting leads. The nomograph of Figure 2-3 can be used to determine the approximate voltage across the connecting wire leads.

2-22. Using the nomograph of Figure 2-3, lay a straight edge from the value of the output current, represented on scale 1, to the gauge of the connecting wires used, represented on scale 2. The voltage across the connecting wires, expressed in millivolts per foot, is obtained from scale 3. To determine the total voltage across the connecting wires, multiply the total length in feet by the value obtained from scale 3. For example, assume that two AWG No. 28 wires, each 3 feet long, are used to connect a load, requiring 50 milliamperes, to the Model 332B. With a straight edge, connect the known current on scale 1 (50 ma) and the wire size on scale 2 (No. 28). The resulting IR drop on scale 3 is approximately 3.2 millivolts per foot. Therefore, the connecting wires develop a total voltage of 19.2 millivolts ($2 \times 3\text{ft} \times 3.2\text{ mv/ft} = 19.2\text{ mv}$), which is several times the published load regulation at 1000 volts output. To compensate for this, the instrument is equipped with remote sensing, which maintains regulation at the load. Consequently, the voltage across the connecting wires will have no effect. Determine if the wire leads used to connect the instrument to the load, will cause a voltage drop in excess of the load regulation specifications. If this voltage drop is excessive, remote sensing should be used. To prepare the instrument for remote sensing, proceed as follows:

- a. With the POWER switch set to OFF, or to STDBY/RESET, remove the front-panel shorting links between the SENSE and OUTPUT terminals.
- b. Using a twisted pair of insulated wires, connect the +SENSE terminal to the positive side of the load, and connect the -SENSE terminal to the negative side of the load.

CAUTION

Ensure that the SENSE terminals are connected to the load in the proper polarity. Incorrect connections will result in loss of regulation and possible damage to the instrument.

2-23. Guard Connection

2-24. When the instrument is connected to another instrument (both instruments grounded through their respective power cords), a potential difference may exist between the power line grounds of the two instruments.

This potential difference can cause circulating ground currents, which could cause errors in the output voltage. To prevent these errors from occurring, the instrument is equipped with a guard. This guard, when properly connected to the load, will provide a separate path for the circulating ground currents, thus eliminating possible errors in the output voltage. For proper connection, connect the GUARD terminal directly to the grounded side of the load, at the load. Figure 2-4 illustrates the correct GUARD terminal connection and the re-routed circulating ground current path.

2-25. OPERATION

2-26. Operate the instrument in accordance with the following procedure:

- a. Set the METER switch to VOLTAGE.
- b. Set the POWER switch in the STDBY/RESET position. Allow at least a 10 minute warm-up period, if the instrument has just been energized.

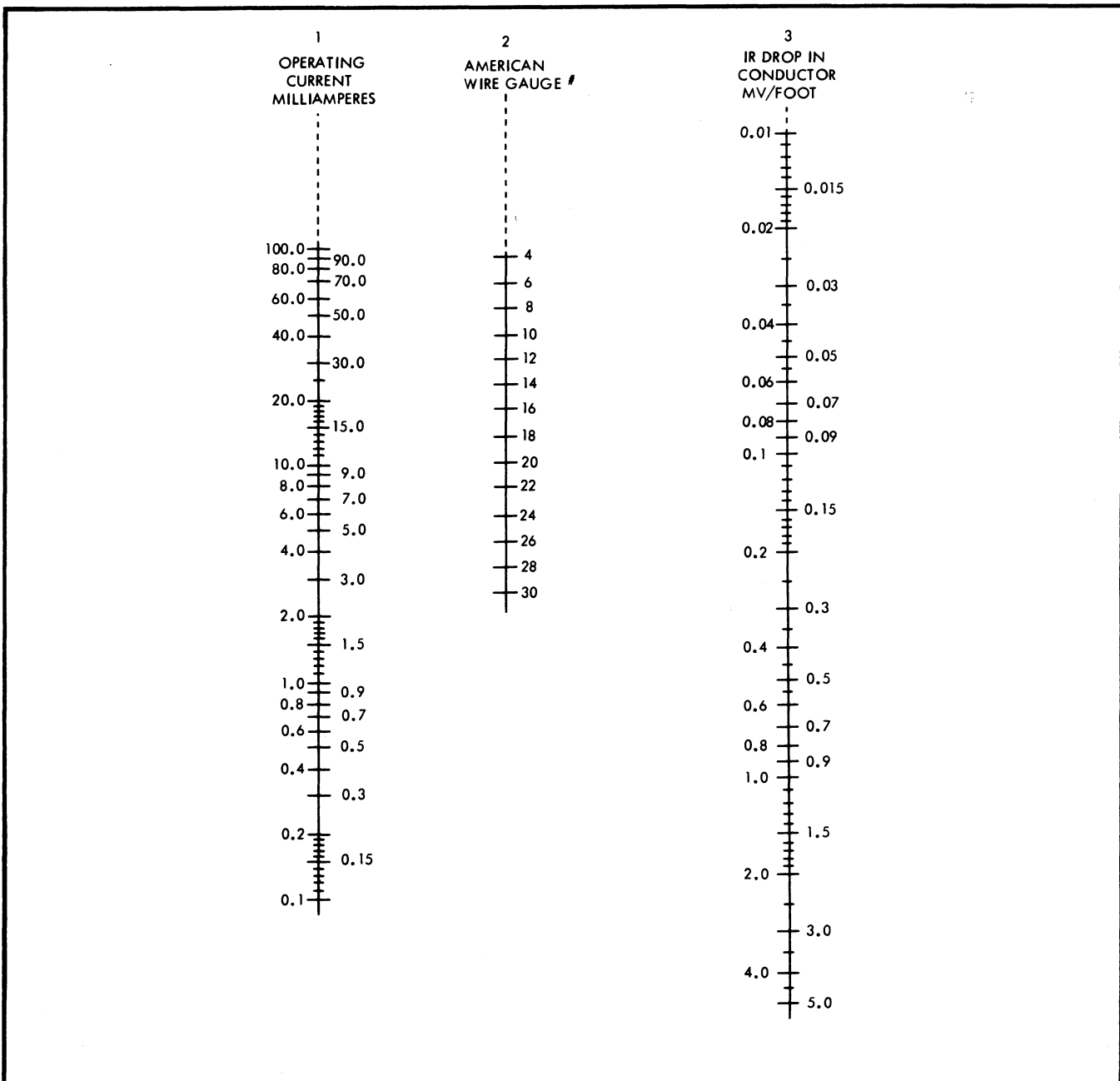

Figure 2-3. NOMOGRAPH OF VOLTAGE DROP ACROSS LOAD WIRES

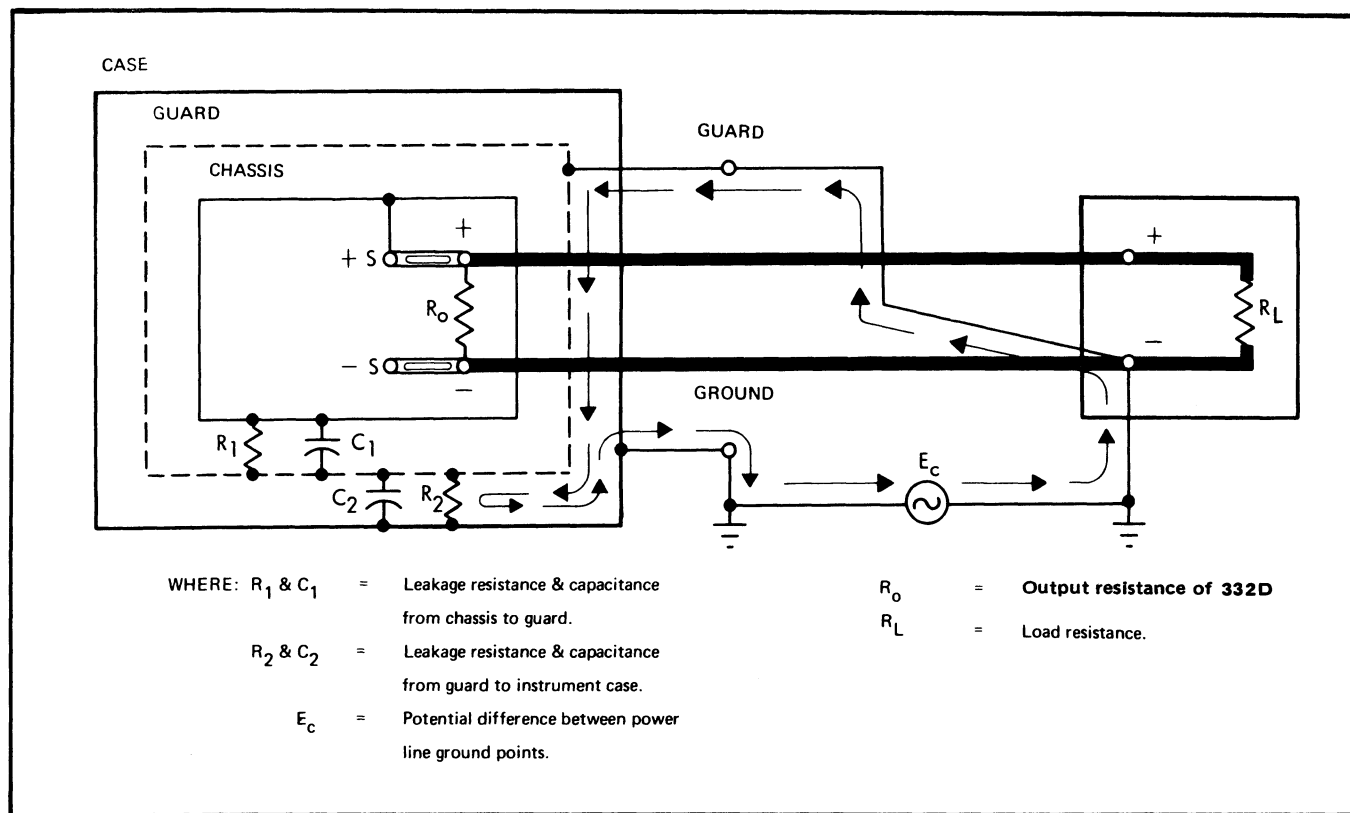

Figure 2-4. GUARD CONNECTION

- c. Connect the SENSE terminals to the OUTPUT terminals with the shorting links provided.
- d. Set the CURRENT LIMIT control fully clockwise (60) or to a predetermined value, using the procedure of paragraph 2-20.
- e. Set the RANGE switch to the desired output voltage range (10, 100, or 1000).
- f. Set the VOLTAGE TRIP and VERNIER controls fully clockwise or to a predetermined value, using the procedure of paragraph 2-18.
- g. Set the readout dials to the value of the output voltage desired.
- h. If desired, connect the GUARD terminal to the grounded side of the load in accordance with paragraph 2-25. The SENSE terminals may remain connected to the OUTPUT terminals. Should remote sensing be desired, connect the SENSE terminals to the load in accordance with paragraph 2-22.
- i. Connect the load to the OUTPUT terminals.
- j. Set the POWER switch to the OPR position.
- k. The output voltage provided to the load will be the voltage indicated on the readout dials. Should it be desirable to monitor the output current, place the METER switch in the CURRENT position.

Section 3

Theory of Operation

3-1. INTRODUCTION

3-2. This section describes the theory of operation of the Model 332D. In conjunction with the text, refer to the functional schematic diagrams located in the rear of the manual. Before attempting to trouble shoot the unit in detail, one should be thoroughly familiar with circuit operation.

3-3. FUNCTIONAL DESCRIPTION

3-4. This voltage standard is a series regulated power supply basically consisting of the voltage control circuitry, preregulation circuitry, and protection circuitry. The voltage control circuits are the main regulation circuits and respond to load, RANGE, and readout dial changes. Figure 3-1 illustrates a simplified schematic diagram of the voltage control circuitry. The error amplifier and series pass element, illustrated in the shaded portion, together constitute a dc operational amplifier. The tendency of the operational amplifier is to maintain the summing point effectively at +SENSE potential. In this condition the output voltage of the voltage standard is equal to the ratio of the sample string resistance (R_{READOUT}) to the range resistance (R_{RANGE}) times the reference ($E_{\text{REFERENCE}}$), as illustrated in Figure 3-1. The constant reference voltage ($E_{\text{REFERENCE}}$), in combination with the appropriate series resistance (R_{RANGE}), provides a constant current to the sample string. Due to the constant current, the output is proportional to the resistance of the sample string (R_{READOUT}). Since the tendency of the operational amplifier is to maintain the summing point at +SENSE potential, the output voltage is equal to the sample string voltage. Changing the setting of the readout dials (sample string) causes the output

voltage to change correspondingly. Each change in the RANGE switch setting causes the constant current to change by a factor of 10, thus the output voltage changes by the same factor. A detailed block diagram is illustrated in the Functional Block Diagram (332B-1500), at the back of the manual. In this diagram, the chopper amplifier, differential amplifier, and series pass driver constitute the error amplifier of Figure 3-1.

3-5. Series regulated power supplies have the inherent disadvantage of low efficiency. When providing a low level output, the series pass element of the supply must dissipate the bulk of the power supplied by the high voltage transformer circuit. In this instrument, a unijunction oscillator circuit monitors the voltage across the series pass element and provides a voltage level information to a pre-regulation circuit. The pre-regulation circuit utilizes this information to provide full-wave control of the input line voltage to the primary of the high voltage transformer. Thus, the power supplied by the high voltage transformer is controlled to provide only that amount necessary for the load requirements. This in turn increases the overall efficiency of the instrument. This also accounts for symbolizing the unregulated dc voltage, in Figure 3-1, as a variable dc voltage.

3-6. Circuitry, for protection of personnel as well as external equipment, is provided. The instrument contains an interlock system to de-energize the high voltage circuits within the instrument when the covers are removed. A limit may be set for the output voltage and/or current. Whenever the output voltage or current tries to exceed the set limits, the instrument output is de-energized. Therefore, sensitive external equipment can be protected from excessive voltage and current.

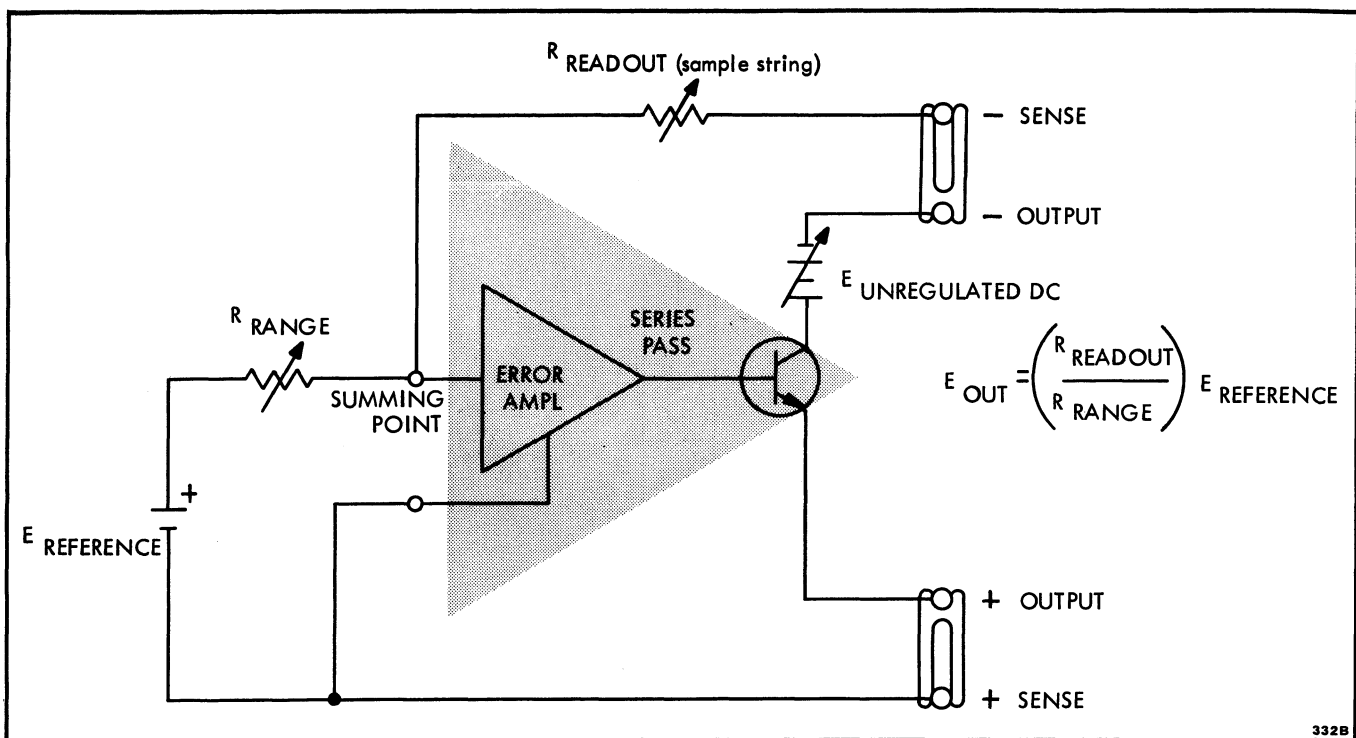

Figure 3-1. VOLTAGE CONTROL CIRCUITRY

3-7. CIRCUIT DESCRIPTIONS

3-8. Voltage Control Circuitry

3-9. REFERENCE SUPPLY. The master reference voltage for the instrument is produced in the A5A1 Reference Supply (332B-1083). This assembly consists of a +15V dc reference supply, an oven temperature regulator for the reference supply, and divider networks for compensation of offset voltages when the output is set to zero.

3-10. The Reference supply is composed of differential amplifier A2 and zener reference amplifier A3. The reference amplifier is enclosed in an oven which maintains a constant temperature for environmental stability. Selection of the values of R7A and R7B scales the output of the Reference Supply to +15V dc. Variable resistor R9 allows adjustment of the resulting V_{REF} output. Temperature coefficient of the base/emitter voltage for A3 is accurately matched to the zener element through selection of R13. The resulting stable reference at the collector of A3 is applied to the non-inverting input of A2. The other input to A2 receives an equivalent voltage from the divider composed of R14 and R15. Any change in V_{REF} is sensed at the base of A3 and the resulting amplified change applied to the non-inverting input of A2. This change then alters the conduction of A2 such that V_{REF} is maintained at +15V dc.

3-11. Constant operating temperature for the reference amplifier A3 is provided by the Oven Temperature Regulator Q1 and A1. The series-pass regulator composed of Q1 and A1 establishes a constant voltage across the heater element of A3. Any variation in heater voltage is sensed by A1 and amplified. The resulting output of A1 then alters the conduction of Q1 to eliminate the voltage variation across the heater element. The heater element consists of a semiconductor material which has moderate conductivity at temperatures below a specific stabilization point and a marked decrease in conductivity as the temperature approaches the stabilization point. Application of a constant voltage to the heater provides a fast warm-up and a much more stable operating temperature.

3-12. The divider network composed of R1 through R6 provide a bias voltage to one input of the A5A4 Chopper Amplifier. Potentiometers R2, R4, and R6 are adjusted to compensate for offsets in the 10V, 100V, and 1000V ranges when the output is set to zero.

3-13. RANGE RESISTORS. The A4 Range Cal (332B-1052) provides three separate adjustable range resistors. These resistors together with the A2 Sample String form a resistive divider which determines the output voltage of the instrument.

3-14. **SAMPLE STRING.** The A2 Sample String (332B-1051) together with the selected range resistor in the A4 Range Cal forms a resistive divider, the ratio of which is controlled by the front panel decade dials. The output voltage of the sample string is proportional to the reference voltage multiplied by the ratio of the sample string resistance to the A4 range resistance.

3-15. **CHOPPER AMPLIFIER.** The A5A4 Chopper Amplifier (332B-1058) compares low frequency and dc control signals from the A2 Sample String output to the +SENSE terminal voltage and amplifies any difference. The circuitry consists of an input filter, a MOSFET chopper, an operational amplifier, a synchronous demodulator, an output filter, and a multivibrator.

3-16. Low frequency and dc control signals at terminal 6 are passed through the input filter C2, R1, C3 to reject frequencies above 30 Hz. The MOSFET chopper Q1 modulates the signal appearing at the junction of C4 and output signal at Q2 is then amplified by the operational amplifier IC1, which has a gain of approximately 420. The paraphase amplifier Q3 amplifies the output of IC1 and provides two equal amplitude, but 180° out-of-phase signals. The collector signal of Q3 is coupled by C16 to the shunt demodulator Q4. The resulting demodulated signal appearing at the junction of C17 and R24 is filtered by R24, R26 and C18, leaving only the amplified dc and low frequency signals. The emitter signal of Q3 is applied through C14, R21, C15, R25, R23, and C22 to C18, where it is used to cancel any chopper ripple at 270 Hz.

3-17. The 270 Hz multivibrator is formed by Q6, Q7 and associated timing networks, in addition to a driver Q5. Variable resistor R43 adjusts the level of the signal applied to the driver Q5, and subsequently the output signal applied to the gate of Q1. The collector signal of Q5 is applied to Q1 across C5 to compensate for spikes coupled through Q1. Variable resistor R34 provides adjustment of the compensation signal. An output signal at the collector of Q7 is applied to the base of Q4, which synchronously demodulates the Chopper Amplifier output.

3-18. **DIFFERENTIAL AMPLIFIER.** Error signals in the form of ac changes are applied to the A5A3 Differential Amplifier (332B-1057). These signals are coupled through C1 to the gate of Field Effect Transistor (FET) Q2. Error signals appearing as dc changes are applied to the chopper amplifier at the base of Q6. Using a separate path for ac changes allows rapid regulation of the output voltage for rapid changes in load requirements. The

Differential Amplifier P/C Assembly provides an output that is proportional to the amplified dc error signal from the Chopper Amplifier P/C Assembly.

3-19. Use of a Field Effect Transistor for Q2 provides high input impedance and low noise. Transistor Q8 is a current source for one stage of the differential amplifier. Use of the current source provides high gain and good common mode rejection at the input of the amplifier. The compound configuration of Q4-Q5 and Q6-Q7 provides high input impedance and minimizes temperature effects. The output signal from the collector of Q9 is applied to the base of the common collector amplifier Q11. Transistor Q11 provides impedance matching between the high output impedance of Q9 and the low input impedance of the series pass driver circuit.

3-20. **SERIES PASS.** The A7A1 Series Pass (332B-1061) contains the series-pass transistors which control the output voltage. It also contains a voltage controlled oscillator (VCO) and control amplifiers which are part of the preregulator, a power supply, and an automatic "crowbar" driver.

3-21. The power supply composed essentially of CR1 through CR4 produces the required operating voltages for the series pass circuitry. AC voltage at terminals 8 and 9 is rectified by CR1 through CR4 to provide an unfiltered positive voltage. This voltage is isolated by CR5 and filtered by C2 to provide a +150V dc operating voltage for the series-pass transistors. The voltage divider of R1 through R3 and zener CR6 produces a clipped, full-wave rectified 16V synchronizing signal for the VCO.

3-22. Output voltage of the instrument is established and maintained by the series-pass transistors, Q1 through Q8. The transistors Q1 through Q7 are normally saturated and Q8 is absorbing the total voltage required to maintain the output of the instrument. However, when the output level or load current is changed and the voltage across Q8 exceeds 150V, Q1 through Q7 absorb the additional voltage. The preregulator circuitry then reduces the output of the A7 H.V. Mother Board until the voltage across Q8 is less than 150V. When this condition is reached, Q1 through Q7 again saturate and Q8 absorbs the total regulation voltage.

3-23. The automatic "crowbar" consisting of Q10 monitors the total voltage drop across the series-pass transistors. Load or output changes that cause the voltage across the series-pass to exceed 225V will cause Q10 to conduct. Its conduction energizes K2 on the A7 H. V. Mother Board and places a load across the high voltage rectifier, thus limiting

the voltage across the series-pass transistors.

3-24. Unijunction transistor Q9 and C3, L3, R37, CR18, R35, and CR19 form a VCO which furnishes turn-off pulses to the preregulator circuitry. This VCO is synchronized to the ac line zero crossing through amplifiers Q11 and Q12.

3-25. A clipped 16V pulse is rectified by CR32 and C5 to provide operating voltage for the base of the VCO, Q9. This voltage is clamped to zero during the ac line zero interval by amplifiers Q11 and Q12. The divider composed of R36 and R42 provides a sample of the clipped 16V pulse at the base of Q12. When the pulse is at 0V, Q12 produces an amplified positive pulse at its collector. This pulse is differentiated by C4 and R41 and the resulting positive spike momentarily turns on Q11. Conduction of Q11 clamps the output of rectifier CR32, C5 to zero, thus synchronizing the output of Q9 to the ac line zero crossing. The output pulses from Q9 are dependent upon the voltage charge on C3. The voltage is sensed across Q8 through the divider consisting of L3, R37, R35, CR18, and CR19. If this voltage increases, Q9 will produce a preregulator turn off pulse earlier in the ac line cycle, thus reducing the ac power available to the A7 H.V. Mother Board. Conversely, should the voltage across Q8 decrease, the ac power to the A7 H.V. Mother Board is increased.

3-26. **POWER SUPPLIES.** Operating voltages for the temperature regulating circuit, zener reference circuit, chopper amplifier, and differential amplifier are provided by the A5A5 Auxiliary Power Supply P/C Assembly (332B-1059). The auxiliary power supply consists of the 25 volt supply and -15 volt supply circuits. The auxiliary supply reference element is located in the 25 volt supply. The output of the 25 volt supply is then used as the reference for regulation of the -15 volt supply.

3-27. In the 25 volt supply, CR1 through CR4, C2, R4, and C3 provide unregulated dc voltage to the regulation circuitry consisting of Q2 through Q6. Transistors Q5 and Q6 constitute a differential amplifier. The base of Q6 is held at a constant voltage by zener diode CR6. The base of Q5 is connected to a voltage divider, consisting of R8, R9, and R10, referenced to the output of the supply. Variations in the +25 volt output of the supply are sensed at the base of Q5. Any difference between the base voltages of Q5 and Q6 is amplified by the differential pair and applied from the collector of Q5 to the base of series pass driver Q3. The amplified error signal controls the conduction of Q3, which in turn controls the series pass element Q4. Transistor Q2 is a constant current source to supply base drive to Q3.

3-28. In the -15 volt supply, CR7 through CR10, R14, and C8 provide the unregulated dc voltage to the regulating circuit consisting of series pass element Q7 and differential pair Q8 and Q9. The base of Q9 is connected to a voltage divider referenced to the +25 volt supply output. The base of Q8 is connected to the positive side of the -15 volt supply. Variations in the output voltage are sensed at the base of Q9. Any difference between the base voltages of Q8 and Q9 is amplified by the differential pair and applied from the collector of Q8 to the base of series pass element Q7. The amplified error signal controls the conduction of Q7 and consequently the magnitude of the output voltage. The positive side of the -15 volt supply is connected to the negative side of the +25 volt supply through pins 11 and 12. The + sense line is connected to this junction and is the common for the auxiliary power supply.

3-29. The ± 35 volt operating voltages for the series pass driver circuitry on the A5A2 Series Pass Driver P/C is provided by a power supply located on the A5A6 Current Limiter P/C Assembly (332B-1060). In the diode bridge configuration of CR1 through CR4, diodes CR1 and CR2, R1 and C1 provide a positive unregulated dc voltage. Diodes CR3 and CR4, R4, and C4 provide negative unregulated dc voltage. The positive unregulated dc voltage is applied to the regulating circuit of Q1 and CR5 and through a voltage divider to the RANGE switch, for application to the appropriate decimal lamp. The 36 volt reference voltage, established by CR5, provides the input signal for the emitter follower configuration of Q1. This emitter follower configuration provides the necessary low output impedance and power gain of the power supply. The -35 volt supply functions in the same manner as the +35 volt supply.

3-30. Pre-Regulation Circuitry

3-31. **OSCILLATOR.** A unijunction oscillator, consisting of Q9 and associated circuitry, is located on the A7A1 Series Pass Element P/C Assembly (332B-1060). Applied to base two of Q9 is a 6.8v clipped, full-wave rectified, 60 Hz sine wave. The potential at the emitter of Q9 depends upon the charge of C4 and C5. The charge of C5 depends upon the voltage across the main series pass element, Q8. At the trailing edge of each pulse at the base two of Q9, the oscillator provides a series of positive pulses until the leading edge of the next +6.8 volt pulse occurs. With an increased charge across C4 and C5, the initial output pulse of the oscillator will occur earlier in each half cycle. The initial pulse from the oscillator during each half cycle will switch the preregulator off to control the amount of line power supplied to the high

voltage transformer. If the series pass element voltage of Q8 increases, the pre-regulator is switched off earlier in each half cycle. This in turn reduces the series pass element voltage of Q8 to its equilibrium value.

3-32. The +6.8 volt operating voltage for the oscillator circuit is taken from the +150 volt supply for the series pass element. A portion of the +150 volt supply is applied to the voltage divider consisting of R1 through R3. The divided-down voltage is regulated by zener diode CR6 to approximately +6.8 volts.

3-33. **PREREGULATOR.** The A7A2 Preregulator (332B-1082) controls the ac power supplied to the instrument by passing only enough power to the A7 H. V. Mother Board to meet the output load requirement. It consists of a $\pm V$ supply, a relay power supply, preregulator control drivers, a preregulator bridge, and a current limiter.

3-34. $\pm V$ and +10V dc operating voltages are produced for the A7A2 Preregulator by the rectifier CR1 through CR4 and associated components. A 10V ac input is applied to CR1 through CR4. The dc output at the junction of CR2 and CR4 is filtered by C3 to provide a $-V$ operating voltage. The dc voltage at the junction of CR3 and CR1 is heavily loaded by R1 to provide an unfiltered +V operating voltage. This voltage is also isolated through CR5 and filtered by C4 to provide a +10V dc operating voltage.

3-35. Operating voltage for relay K1, which supplies ac voltage to the preregulator bridge, is produced by bridge rectifier CR6 through CR9 and K2. AC return for the bridge rectifier is provided through the contacts of K2. This relay is energized only in the OPR mode by a control voltage from the A5A2 Series Pass Driver. The A5A2 Series Pass Driver automatically removes the control voltage from K2 should a VOLTAGE TRIP occur, thus removing ac power to the preregulator bridge and establishing a STDBY condition.

3-36. The circuitry consisting of Q2 through Q9 controls the conduction of the preregulator bridge attenuator, Q1. Input pulses from the VCO in the A7A1 Series Pass are supplied to the base of Q7 via terminal 14. The first pulse turns on Q7 and Q6, which through regenerative action, saturate. This condition turns off Q5 and causes Q4 and Q8 to also turn off. Q9 is subsequently turned on by the $-V$ collector voltage of Q8 and provides a negative voltage at the base of Q2. This condition turns off Q2 and also Q1, thus causing the preregulator bridge of CR10 through CR13 and Q1 to provide maximum attenuation to the ac voltage applied to the A7 H.V. Motherboard. When

the ac line passes through zero, the 0V, +V condition at the emitter of Q6 causes it to turn off and also turns off Q7. This condition reverses the previously described state of each transistor and the preregulator bridge again passes the ac line voltage to the A7 H.V. Motherboard.

3-37. AC line voltage applied to T2 and subsequently the A7 H.V. Motherboard is controlled through the pre-regulator bridge consisting of CR10 through CR13 and Q1. The previously described circuitry of Q2 through A9 controls conduction of Q1. Diodes CR10 through CR13 provide a unidirectional current through Q1. Positive alternations are passed by CR10 and CR13. CR12 and CR11 pass negative alternations. Should Q1 be cut off, C6 and R5 provide a dynamic load for the bridge. Overload current protection for Q1 is provided through divider R2, R8, and R9 and Q3. Should the current through Q1 exceed 17 amperes, the voltage at the base of Q3 turns it on and causes Q6 to saturate. This condition causes Q1 to be cut off, thus limiting the current through the preregulator bridge.

3-38. Protection Circuitry

3-39. **Trip.** The purpose of the trip circuit is to remove ac power from the primary of the high voltage transformer and to open the negative output path, if an overvoltage or catastrophic overcurrent condition exists. The trip circuitry is located on the A5A2 Series Pass Driver P/C Assembly (335A-1056). Transistor Q3 is a constant current source for relays A7K1 and A7A2K2. With A7A2K2 (on the Pre-Regulator P/C Assembly) closed, current is provided to A7A2K1 which completes the primary circuit for the high voltage transformer. With relay A7K1 (on the High Voltage Motherboard P/C Assembly) closed, the negative output path is completed and power may be supplied to the load. The current sensing resistor, R22, is effectively connected through R24 to the base of normally off Q4. In the event of a catastrophic failure, in which the current limiting circuitry would not function, an excessive current approaching 120 milliamperes would develop sufficient voltage across R22 to turn on Q4. Because of the regenerative configuration, transistors Q4 and Q2 would become saturated. With Q2 saturated, the potential at pin 10 becomes nearly the same as the positive buss potential. This bypasses the current away from the relays, which causes them to open. With the relays open, the OUTPUT terminals are de-energized, the input power to the high voltage transformer is interrupted, and the OPR indicator lamp goes out. To reset the instrument, the POWER switch is placed in the STDBY/RESET position; then to the OPR position after the cause of the overload

has been corrected. With the POWER switch in the STDBY/RESET position, the circuit common is connected through a section of the POWER switch and pin 10 to the emitter of Q2. This results in turning off both Q2 and Q4, and thus returning them to their original state.

3-40. The overvoltage trip element is Q1. The base of Q1 is connected to R15 and the appropriate resistor selected by the VOLTAGE TRIP switch. The voltage trip point is selected by the VERNIER control (R5), which sets a reference bias on Q1 (maintaining Q1 cut off). As the output voltage increases, the voltage at the base of Q1 increases negatively until it exceeds the selected trip voltage and causes Q1 to conduct. The conduction of Q1 saturates Q2 and results in de-energizing the instrument output terminals, as previously described.

3-41. CURRENT LIMIT. The current limit circuitry, located on the A5A6 Current Limiter P/C Assembly (332B-1060), provides a means of varying the limiting point of the output current. Current sensing resistor R22 on the A5A2 Series Pass Driver P/C Assembly provides a voltage to the current limiter circuit that is proportional to the output current. This voltage is applied through pin 10 and CR12 to the base of Q5. The emitter of Q5 is connected to the wiper of the CURRENT LIMIT control (R6), which provides a variable bias for the base-emitter junction. Transistor Q5 is normally off; however, when the output current exceeds the set limit, Q5 turns on. Conduction of A5 causes both Q4 and Q3 to conduct. Conduction of Q3 causes Q1, on the Differential Amplifier P/C Assembly, to conduct and bypass some of the sample string current. This causes the output voltage to be reduced and consequently the output current is reduced. The conduction of Q3 also turns on the regenerative pair, Q6 and Q7, which supply current to the red indicator lamp.

3-42. INTERLOCKS. The Model 332D is equipped with an interlock circuit for personnel safety (332B-1000). When either the top or bottom inner covers or printed circuit assemblies A7A2, A7, A7A1, A5A1, A5A3, A5A4, A5A5, or A5A6 are removed, the ground return for the A7K1 and A7A2K2 relays is opened. This results in removal of the input power to the high voltage transformer (T2) and opens the negative output side of the instrument.

3-43. TIME DELAY. The purpose of the time delay circuit, located on the A6 Time Delay P/C Assembly (332B-1020), is to provide a short interval for the auxiliary voltages to rise to nominal value. This ensures that the control amplifiers are operating before the high voltage is available. The time delay circuit momentarily holds open

relays A7K1 and A7A2K2, which prevent the closure of A7A2K1. The time delay is approximately 3 seconds. Diodes 2001 and 2002 provide a full-wave rectified voltage from a secondary winding of the power transformer between pins 20 and 22. When the POWER switch is in the STDBY/RESET position, a small current flows through R2001, S1c, K2001, R2004, and C2001. This current, although too small to actuate K2001, charges C2001. Capacitor C2001 charges until it reaches the firing point of Q2001, approximately 2 to 3 seconds. At this point Q2001 conducts, increasing the current through K2001. The relay actuates and closes contact K2001A (which provides the current path when the POWER switch is in the OPR position) and opens contact K2001B. When K2001B opens, the grounding circuit is removed from the constant current source supplying A7K1 and A7A2K2, and these relays are allowed to actuate.

3-44. Miscellaneous Circuitry

3-45. OUTPUT CIRCUIT CURRENT SOURCE. In addition to the main high voltage bridge rectifier, CR1 through CR10 on the A7 High Voltage Mother Board P/C Assembly Schematic (332B-1056), there is another high voltage bridge (CR13 through CR20). This bridge-rectifier is in series with R27 and R28 and forms a quasi-constant current source. This current flows through the series pass transistors and acts as a minimum load to insure that their transconductance is held above a minimum value. Another purpose of the quasi-constant current source is to provide a quick discharge path for the output capacitor C1, when down ranging. This helps to reduce the setting time.

3-46. CAPACITOR SWITCH. The capacitor switch circuitry is located on the A3 Capacitor Switch P/C Assembly Schematic (332B-1092). When down ranging from 1000 volts, capacitor C4 (on the chassis) will tend to charge to a voltage level proportional to the difference between the charge on C5 and the parallel combination of the output capacitors C1 and C2. If this difference is too great, C4 will receive a charge of sufficient magnitude to cause a dielectric absorption problem, thus excessive settling time will result. (Dielectric absorption is the tendency of the dielectric material of the capacitor to absorb and retain a small charge). To prevent this occurrence, C5 is discharged through R7 (on A3) when the RANGE switch is down ranged from 1000 volts to 10 or 100 volts. In doing so the decay rate of C5 and the parallel combination of C1 and C2 will be equal, thus C4 does not receive an over charge. After C5 has discharged sufficiently (several seconds), the K1A contacts (on A3) close and parallel the low resistance of R6 with R7. This essentially shorts C5 and returns the loop gain to the required amount. The capacitor switch

circuitry is responsible for allowing a time delay before closing the K1A contacts. When down ranging from 1000 volts, C1 is charged by the +35 volt supply through R2 and R1. After several seconds, C1 accumulates a sufficient charge to cause Q1 to conduct. Conduction of Q1 energizes relay K1 which closes the K1A contacts.

3-47. CROWBAR CIRCUIT. If the output voltage were suddenly turned to zero with a load connected to the instrument, the voltage across the filter capacitors C1, C2, and C3 (located on the A7 High Voltage Mother Board P/C) would appear across the series pass transistors. This voltage could damage the series pass transistors. To protect the series pass transistors from this kind of damage, a "crowbar" circuit is utilized. (The term "crowbar" is derived from the use of such a device to discharge large capacitor banks in transmitter power supplies). The "crowbar" circuit consists of transistor Q10 and associated circuitry on the A7A1 Series Pass Element

P/C. It also includes relay K2 on the A7 High Voltage Mother Board P/C. When the voltage across the series pass element reaches approximately 225 volts, transistor A10 conducts. Since relay K2 is in the collector circuit of Q10, the relay is energized and closes the contacts. With the K2A contacts closed, a discharge path through R15 is provided for the filter capacitors.

3-48. METER CIRCUIT. The front panel meter indicates the output voltage or output current, depending on the position of the METER switch. When the METER switch is in the VOLTAGE position, resistors R3 through R6, on the Series Pass Driver P/C Assembly, and the resistors selected by the RANGE switch S2f provide the meter with a current which is proportional to the output voltage. When the METER switch is in the CURRENT position, resistors R1 and R2, on the Series Pass Driver P/C Assembly, provide the meter with a current which is proportional to the output current.

Section 4

Maintenance

4-1. INTRODUCTION

4-2. Maintenance and calibration of the Model 332D is covered in this section. Paragraph 4-6, GENERAL MAINTENANCE, covers unique and miscellaneous maintenance procedures. A series of checks to determine if the instrument operates properly plus information to aid in localizing problem areas, should any of these checks fail, is covered under paragraph 4-20, PERFORMANCE TESTS. Paragraph 4-36, PERFORMANCE TESTS. Paragraph 4-36, CALIBRATION, contains procedures for alignment of circuits and final accuracy adjustments.

4-3. SERVICE INFORMATION

4-4. Each instrument manufactured by the John Fluke Manufacturing Company is warranted for a period of one year upon delivery to the original purchaser. Complete warranty information is contained in the Warranty page located at the front of this manual.

4-5. Factory authorized calibration and repair service for all Fluke instruments are available at various world wide locations. A complete list of factory authorized service centers is located in Section 7 of this manual. If requested, an estimate will be provided to the customer before any repair work is begun on instruments beyond the warranty period.

4-6. GENERAL MAINTENANCE

4-7. Maintenance Access

WARNING

**The inner chassis is at +OUTPUT potential!
Hazardous voltages exist between inner chassis
and front panel.**

4-8. The chassis may be easily removed from the outer case by unfastening the two Dzus fasteners, located at the rear of the case. To obtain access to the circuitry within the chassis, the top and/or bottom inner covers must be removed. Removal of the top and/or bottom covers opens one or both of the interlock switches. To have the instrument fully operable, with the top and/or bottom covers off, the interlocks must be "cheated".

4-9. Located on the left side of the instrument, behind bulkhead, is an extender card A8. This board is used as an extender for the plug-in circuit board assemblies to provide access to adjustments and test points.

CAUTION!

**Remove all power from the instrument before
removing or inserting plug-in circuit boards.**

Remove the plug-in circuit board assembly to be investigated, insert the extender card in its place, and plug the circuit board assembly in the extender card.

4-10. Unique Maintenance Procedures

4-11. **CLEANING OF BOARDS.** Certain circuit board assemblies are ultrasonically cleaned at the factory to prevent the possibility of electrical leakage caused by contamination from handling during assembly. These circuit board assemblies include the Sample String P/C Assembly (A2), and Capacitor P/C Assembly (A1). When components are replaced on these assemblies that require soldering, the land pattern side of the board should be cleaned as described in paragraph 4-12. Should contamination be suspected on the component side of the circuit board, use Freon TF Degreaser (Miller-Stephenson Chemical Co.).

4-12. **CIRCUIT BOARD SEALANT.** The land pattern side of all printed circuit boards have been coated with epocast (a polyurethane resin) to inhibit fungus growth and moisture absorption. When soldering to a printed circuit land, the heat from the soldering iron decomposes the epocast resin, leaving a charred residue. Upon completion of soldering, the residue should be removed with a solvent such as toluol.

4-13. After removal of the epocast residue, the affected area should be recoated with a sealant. A spray can of Circuit Coat (Furane Plastic Inc., 4516 Brazil Street, Los California or 16 Spielman Road, Fairfield, New Jersey) may be used for recoating.

4-14. Fuse Replacement

4-15. The fuses are contained in bayonet type fuse holders located at the rear of the instrument. Listed below are the correct values for the fuses:

REF. DESIG	FUNCTION	TYPE
F1	High Voltage	¼A, slow blow
F2	Line	3A, slow blow, 115V conn. 1½A, slow blow, 230V conn.

Under no circumstances should replacement fuses with higher current ratings be installed in the instrument.

4-16. Lamp Replacement

4-17. The indicator lamps are located immediately behind the front panel. The instrument must be partially removed from the case to gain access to the lamps. The decimal lamps are easily accessible and removable from the instrument without the need of any special tools.

4-18. 115/230V Conversion

4-19. Depending upon the connection of the power transformers primary windings, the instrument may be operated from either a 115 or 230 volt ac power line. To convert the instrument from one type of power line operation to the other, use the following procedure:

- a. Disconnect the line cord from the power line.
- b. Remove the instrument from the case and place upside down on a suitable work space.
- c. Orient the instrument and perform the appropriate electrical connections as illustrated in Figure 4-1.
- d. Use the proper fuse corresponding to the selected conversion, as discussed in paragraph 4-14.

4-20. PERFORMANCE TESTS

4-21. Introduction

4-22. The following tests are intended for checking performance of the instrument. These tests may be used for incoming inspection, periodic inspections and precalibration checks. It is recommended that these tests be performance prior to calibration.

4-23. Each performance test includes an introductory paragraph which states the purpose of the test and describes the circuitry involved. An understanding of the purpose of each test and the circuitry involved should aid a technician in analyzing a malfunction.

4-24. During the following tests, it will not be necessary to remove the instrument from the case. All external equipment will be connected to the terminals provided on the instrument. Table 4-1 lists the equipment needed for testing and calibrating.

4-25. The load, line and ripple checks do not rely on any calibration adjustments; any major or minor indication should be investigated by troubleshooting. The remaining voltage standard checks do rely on proper calibration adjustments. Should minor out of tolerance indications be observed during these checks, calibration will more than likely correct these problems. However, should the calibration adjustments be ineffectual or at their extreme limits, you will have to investigate the cause of the problem.

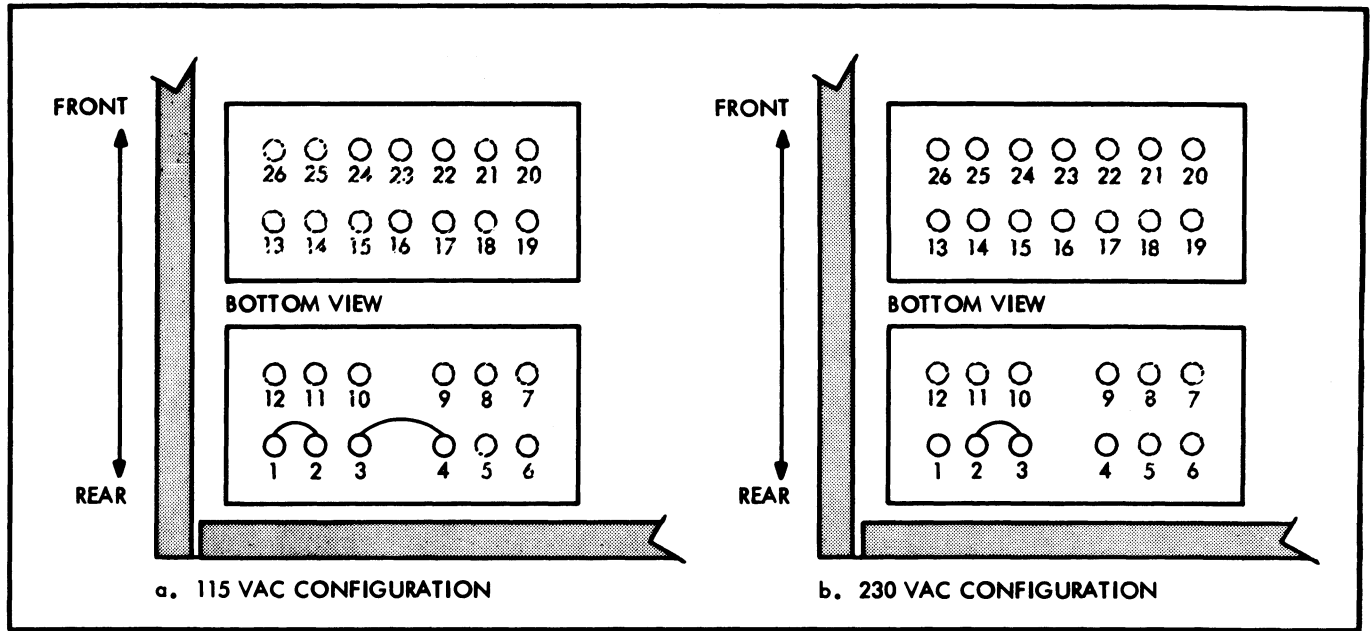

Figure 4-1. 115/230 VAC CONVERSION

EQUIPMENT REQUIRED	SPECIFICATIONS REQUIRED
Volt/Ohmmeter - RCA VoltOhmyst or equivalent	DC Accuracy of $\pm 3\%$ and input impedance of $10\text{ M}\Omega$
Metered Autotransformer - General Radio Variac W5MT3A or equivalent	Output of 0 to 130 vac at 3 amperes.
DC Differential Voltmeter - Fluke Model 895A or equivalent (quantity of 2 required)	DC Accuracy of $\pm 0.0025\%$ with 100 uv null detector
RMS Voltmeter - Fluke Model 931B or equivalent	Accuracy of $\pm(0.05\%$ of input $+0.005\%$ of range) from 30 Hz to 50 kHz.
Preamplifier	Gain of 1000 and bandpass of 20 Hz to 30 kHz
Oscilloscope - Tektronix Type 541 or equivalent Preamplifier - Tektronix Type D	General purpose 1 mv / cm sensitivity
General Purpose Power Supply	Provide 5.5 volts
DC Milliammeter	0 to 100 milliamperes $\pm 5\%$
Load Resistor Box - Clarostat 240-C	Resistance range of 20 to $20,000\Omega$ at $\pm 5\%$. Capable of handling up to 80 watts
Resistor, Composition	$100\text{k}\Omega \pm 5\%$, $\frac{1}{2}\text{w}$

Table 4-1. TEST AND CALIBRATION EQUIPMENT REQUIRED (Sheet 1 of 2)

EQUIPMENT REQUIRED	SPECIFICATIONS REQUIRED
Lead Set	Low-leakage, low-thermal emf
Standard Cell Enclosure- Guildline Model 9152	Accuracy of $\pm 0.0003\%$
DC Voltage Calibration System - Fluke Model 7101B consisting of the following equipment, or an equivalent system: Voltage Standard, Model 332D Null Detector, Model 845AR Voltage Divider, Model 750A Kelvin-Varley Voltage Divider, Model 720A	Capable of measuring 0.1 to 1100 vdc with 5 ppm accuracy

Table 4-1. TEST AND CALIBRATION EQUIPMENT REQUIRED (Sheet 2 of 2)

4-26. In the event that a malfunction is discovered, complete as many of the performance tests as possible. Record which tests the instrument does not successfully pass and any abnormal indications. This will help in analyzing the problem and lead to more efficient troubleshooting.

4-27. DC Output

4-28. **LINE REGULATION.** The line regulation test determines whether the output voltage will remain constant, within specified limits, for a low to high line input power change.

- a. Connect the line cord through an autotransformer connected to an ac power line. Set the autotransformer to 115 volts ac.
- b. Set the front panel controls as follows:

POWER	STDBY/RESET
METER	CURRENT
RANGE	10
READOUT	All Zero
VOLTAGE TRIP	1000
VERNIER	Clockwise
CURRENT LIMIT	Clockwise (60)

- c. Connect the Model 895A to the SENSE terminals and set to plus polarity. Connect the 240-C Load Resistor Box to the OUTPUT terminals of the Model 332D.

- d. Set the RANGE switch, readout dials, and load box to the values indicated in the first group of settings in Table 4-2. Set the POWER switch to the OPR position. Note the voltage indicated on the Model 895A. Set the autotransformer to low line (103V). The output voltage change, indicated on the Model 895A, should not exceed the specification listed in Table 4-2. Adjust the autotransformer setting to nominal line (115V). Note the voltage indication on the Model 895A. Set the autotransformer to high line (127V). The voltage change, indicated on the Model 895A, should not exceed the 20 microvolt specification. Repeat this procedure for each group of settings in Table 4-2.

4-29. **LOAD REGULATION.** The load regulation test determines if the output voltage will remain constant, within specified limits, when the output is subjected to a no-load to full-load condition.

- a. Connect the line cord to an autotransformer connected to an ac power line. Set the autotransformer to 115 volts ac.

- b. Set the front panel controls as follows:

POWER	STDBY/RESET
METER	CURRENT
RANGE	10
Readout	All Zero
VOLTAGE TRIP	1000
VERNIER	Clockwise
CURRENT LIMIT	Clockwise (60)

- c. Connect the Model 895A to the SENSE terminals.
- d. Set the RANGE switch and Readout Dials to the values indicated in the first group of settings listed in the Table 4-3. Set the POWER switch to the OPR position. Note the voltage indicated on the Model 895A. Connect the 20-ohm load to the OUTPUT terminals and note output voltage change on the Model 895A. The change should not exceed the specification listed in the table. Repeat step d. for each group of settings.
- e. Repeat step d. for low line (103V) and high line (127V).

4-30. RIPPLE. The ripple test determines if an ac component superimposed on the dc output is within specified limits.

- a. Connect the preamplifier to the OUTPUT terminals. Connect the Model 931 RMS Voltmeter to the output of the preamplifier.
- b. Set the front panel controls as follows:

POWER	STDBY/RESET
METER	CURRENT
RANGE	10
Readout	All Zero
VOLTAGE TRIP	1000
VERNIER	Clockwise
CURRENT LIMIT	Clockwise (60)

- c. With the autotransformer set to nominal line voltage (115 vac), set the POWER switch to OPR. The ripple output should not exceed 20 microvolts.

NOTE!

Ripple indication is via 1000X preamplifier.

- d. Set the readout dials to 10 volts. The ripple output should not exceed 20 microvolts rms.
- e. Connect the 200-ohm load resistor to the OUTPUT terminals. The ripple output should not exceed 20 microvolts rms. Disconnect the load resistor.
- f. Set the readout dials to zero, and set the RANGE switch to 100. The ripple output should not exceed 30 microvolts rms.
- g. Set the readout dials to 100 volts. The ripple output should not exceed 30 microvolts rms.
- h. Connect the 2,000-ohm load resistor to the OUTPUT terminals. The ripple output should not exceed 30 microvolts rms. Disconnect the load resistor.
- i. Set the readout dials to zero, and set the RANGE switch to 1000. The ripple output should not exceed 40 microvolts rms.

RANGE	READOUT	LOAD (50 ma)	SPEC.
10	1.000000	20Ω	10 uv
10	<u>10.000000</u>	200Ω	20 uv
100	10.00000	200Ω	20 uv
100	<u>100.00000</u>	2000Ω	200uv
1000	100.0000	2000Ω	200uv
1000	<u>1000.0000</u>	20,000Ω	2.0 mv

Table 4-2. CONTROL SETTINGS, LOAD REQUIREMENTS, AND LIMITS FOR LINE REGULATION

RANGE	READOUT	LOAD(50 ma)	SPEC.
10	1.000000	20Ω	10 uv
10	<u>10.000000</u>	200Ω	20 uv
100	10.00000	200Ω	20 uv
100	<u>100.00000</u>	2000Ω	200 uv
1000	100.0000	2000Ω	200 uv
1000	<u>1000.0000</u>	20,000Ω	2.0 mv

Table 4-3. CONTROL SETTINGS, LOAD REQUIREMENTS, AND LIMITS FOR LOAD REGULATION

- j. Set the readout dials to 1000 volts. The ripple output should not exceed 40 microvolts rms.
- k. Connect the 20,000-ohm load resistor to the OUTPUT terminals. The ripple output should not exceed 40 microvolts rms. Disconnect the load resistor.

4-31. **VOLTAGE STANDARD ACCURACY.** If the voltage standard has successfully passed the line, load, and ripple specifications, it can be assumed to be operating correctly. The output voltage can now be checked and compared to the specifications. These checks should be accomplished after the unit has warmed up for 1 hour at standard reference conditions of $23^{\circ}\text{C} \pm 1^{\circ}$, up to 70% relative humidity, and constant line voltage. One method of checking the instrument accuracy is by comparing the voltages to a saturated standard cell by means of a reference divider. Use the equipment and connections shown in Figure 4-4 and the procedure of paragraph 4-53, steps l. through t.

4-32. Meter and Protection Circuits

4-33. **V-I MONITOR.** This procedure checks the output voltage and current monitor circuitry associated with the front panel meter.

- a. With the **METER** switch in the **VOLTAGE** position, set the **RANGE** switch and readout dials for 100 volts output.
- b. The front panel meter should indicate 100 volts ± 3.0 volts.
- c. Check the meter linearity at the following cardinal points, Table 4-4. All meter indications should be within $\pm 3\%$ of full scale.

RANGE	READOUT
10	1.000000
100	10.00000
1000	100.0000
10	<u>10</u> .000000
1000	<u>1000</u> .0000

Table 4-4. CONTROL SETTINGS
FOR V-I MONITOR TEST

- d. Set the **RANGE** switch to 10 volts, the readout dials to 5 volts, the **CURRENT LIMIT** control maximum clockwise, and the **METER** switch to **CURRENT**.

- e. Connect a 0 to 100 dc milliammeter across the **OUTPUT** terminals.
- f. Rotate the **CURRENT LIMIT** control counter-clockwise until the external meter indicates 50 milliamperes. The front panel meter of the Model 332D should indicate 50 milliamperes on the red scale.
- g. Set the **RANGE** switch to 100 volts, then to 1000 volts. The front panel meter should indicate 50 milliamperes in each position of the **RANGE** switch.

4-34. **CURRENT LIMIT.** This check determines the range of the **CURRENT LIMIT** control, which should be 0.5 to 60 milliamperes.

- a. Set the **POWER** switch to **STDBY/RESET**, the **RANGE** switch to 10 volts, the readout dials to 5 volts, and the **CURRENT LIMIT** control maximum clockwise.
- b. Connect a 0 to 100 dc milliammeter across the output terminals.
- c. Set the **POWER** switch to **OPR**. The external meter should indicate 60 milliamperes.
- d. Rotate the **CURRENT LIMIT** control maximum counter-clockwise. The external meter should indicate 0.5 milliamperes.

4-35. **VOLTAGE TRIP.** This test determines if the trip circuit will actuate during an overvoltage condition on each **RANGE** setting.

- a. Set the **TRIP VERNIER** maximum clockwise. Set the **RANGE VOLTAGE TRIP**, and readout dials to the values indicated in Table 4-5. In each case, rotate the **VERNIER** counter-clockwise from the maximum clockwise position until the trip circuitry just actuates. In each case the **VERNIER** control should be approximately 30° from the maximum clockwise position.

RANGE	VOLTAGE TRIP	READOUT DIALS
10	10	<u>10</u> .X00000
100	100	<u>10X</u> .00000
1000	1000	<u>10XX</u> .X00

Table 4-5. CONTROL SETTINGS
FOR VOLTAGE TRIP CHECK

- b. Set the output of the instrument for 4 volts on the 10 volt range. Set the VOLTAGE TRIP switch to the 10 volt position and the VERNIER control to the 12 o'clock position.
 - c. Set the RANGE switch to 100 volts. The trip circuit should actuate.
 - d. Set the VOLTAGE TRIP switch to the 100 volt position and reset the instrument.
 - e. Set the RANGE switch to the 1000 volt position. The trip circuit should actuate.
 - f. Set the VOLTAGE TRIP switch to the 1000 volt position and the VERNIER maximum clockwise. Re-set the instrument.
 - g. Set the RANGE switch to 100 volts then to 10 volts. The trip circuit should not actuate in either position.
- a. Using the +SENSE terminal as common, connect a Model 895A to pin 10 on the Auxiliary Power Supply P/C Assembly.
 - b. Referring to Figure 4-2, adjust A5A5 R9 until the Model 895A indicates 25 volts, ± 10 millivolts.
 - c. While varying the line voltage from 100 to 130 volts ac, the Model 895A indication should not change more than 40 millivolts.
 - d. Set the POWER switch on OFF and disconnect the Model 895A. Replace the Auxiliary Power Supply P/C Assembly. Return the POWER switch to the STDBY/RESET position.

4-43. CURRENT LIMIT. Proceed as follows:

- a. Set the front panel controls as follows:

POWER	STDBY/RESET
RANGE	10
Readout Dials	5.000000
VOLTAGE TRIP	1000
VERNIER	maximum clockwise
CURRENT LIMIT	maximum clockwise
- b. Connect a 0 to 100 dc milliammeter across the OUTPUT terminals. Set the POWER switch to OPR.
- c. Referring to Figure 4-2, adjust R23 for a 60 milliampere indication on the external meter.
- d. Rotate the CURRENT LIMIT control maximum counter-clockwise. Adjust R24 for a 0.5 milliamperere indication on the external meter.
- e. If necessary, re-adjust R23 and R24 until the range of the CURRENT LIMIT control is from 0.5 to 60 milliamperes.
- f. Set the POWER switch to STDBY/RESET and install the top inner cover.

4-44. OUTPUT CURRENT MONITOR. Proceed as follows:

- a. Set the METER switch to CURRENT and POWER switch to OPR.
- b. Adjust the CURRENT LIMIT control to obtain a 50 milliamperere indication on the external meter.

4-36. CALIBRATION

4-37. Introduction

4-38. The following procedures are intended for calibration. The equipment required is listed in Table 4-1. During the first portion of the calibration procedure, the chassis will have to be removed from the case and the top inner cover removed from the chassis. However, upon removal of the top inner cover it will be necessary to "cheat" the interlock located at the top right-hand edge of the instrument chassis.

4-39. Meter Mechanical Zero

4-40. With the instrument de-energized for at least 3 minutes, adjust the mechanical zero screw (located just below the front panel meter) so that the meter pointer is over the zero position.

4-41. Auxiliary Circuits

4-42. AUXILIARY POWER SUPPLY. With the POWER switch in the OFF position, connect the instrument through an autotransformer to the power line. Adjust the autotransformer for nominal line voltage. Extend the Auxiliary Power Supply P/C Assembly (A5A5) on the extender card provided. Set the POWER switch to the STDBY/RESET position. Allow approximately 10 minutes for warm-up; then proceed as follows:

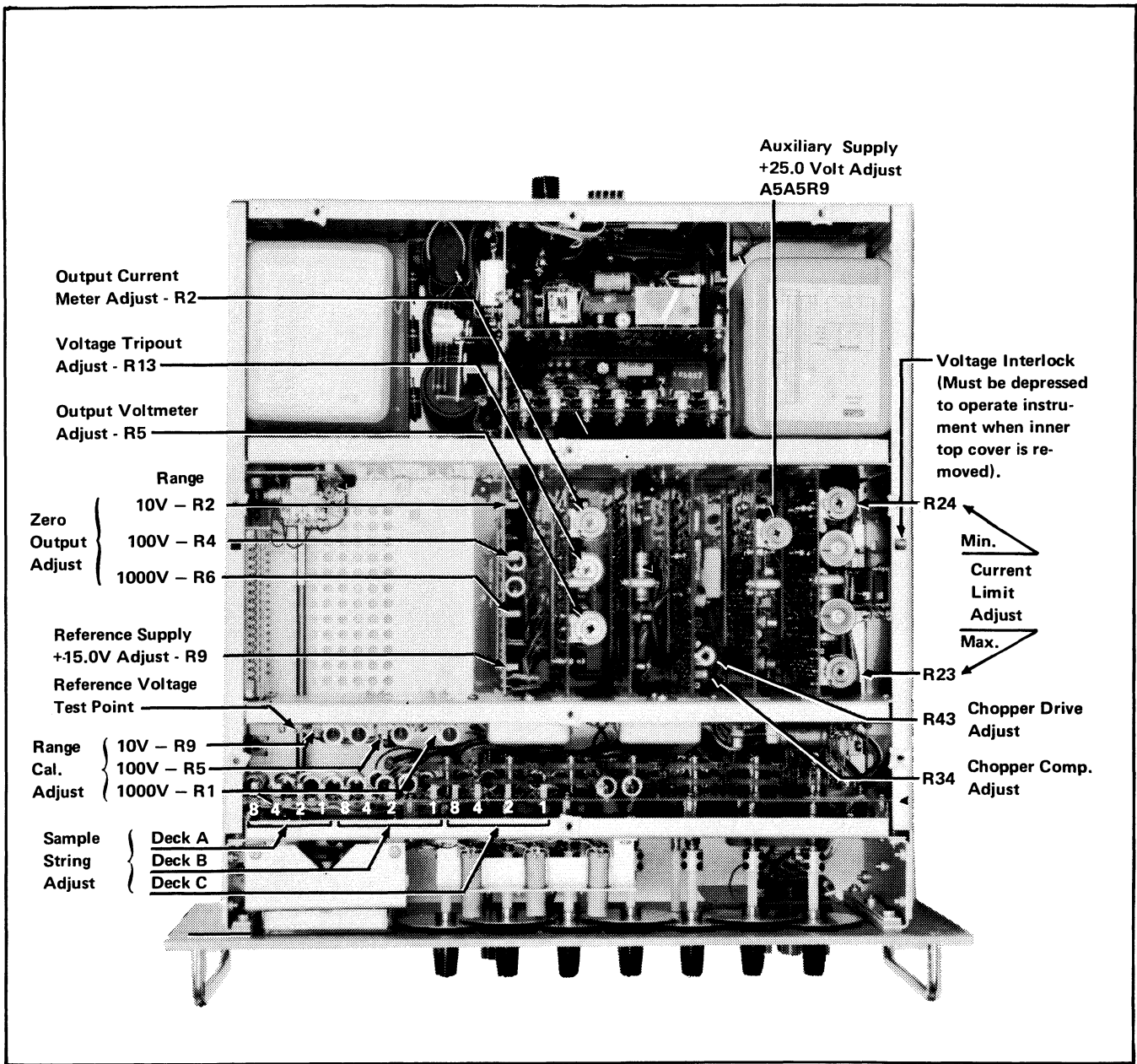

Figure 4-2. LOCATION OF ADJUSTMENTS

- c. Rotate the adjustment labeled OUTPUT CURRENT METER ADJUST until the front-panel meter pointer indicates 50 milliamperes on the red scale.
- d. Set the RANGE switch to 100 volts; then to 1000 volts. The front-panel meter should indicate 50 milliamperes in each position of the RANGE switch.
- e. Set the POWER switch to STDBY/RESET and remove the external meter connections.

4-45. OUTPUT VOLTAGE MONITOR. Proceed as follows:

- a. Set the front panel controls as follows:

POWER	OPR
METER	VOLTAGE
RANGE	100
Readout Dials	<u>100.00000</u>
- b. Rotate the adjustment labeled OUTPUT VOLT-METER ADJUST until the front-panel meter indicates 100 volts ± 0.5 volts.

- c. Meter linearity may be checked at the cardinal points listed in Table 4-6. All full-scale meter indications should be within $\pm 3\%$ of full scale.

RANGE	READOUT DIALS
10	1.000000
100	10.00000
1000	100.0000
10	<u>10</u> .000000
1000	<u>1000</u> .0000

Table 4-6. CONTROL SETTINGS FOR VOLTAGE MONITOR LINEARITY CHECK

- 4-46. VOLTAGE TRIP. Proceed as follows:

- a. Set the front panel controls as follows:

RANGE	100
Readout Dials	<u>10</u> X.00000
VOLTAGE TRIPOUT ADJUST (topcover)	maximum counter-clockwise
VOLTAGE TRIP	100
VERNIER	30° from maximum

- b. Rotate the VOLTAGE TRIPOUT ADJUST until the output is de-energized, as indicated by the illumination of the red indicator lamp and the audible "click" of relays.
- c. Set the POWER switch to STDBY/RESET. Rotate the VERNIER control to the maximum clockwise position.
- d. Set the POWER switch to OPR. Set the RANGE switch, TRIP switch, and readout dials as listed in Table 4-7. Check the trip action on each range by rotating the VERNIER control counter-clockwise. The trip point should occur in each RANGE switch position when the VERNIER control is approximately 30° from the maximum clockwise position.

TRIP	RANGE	READOUT DIALS
10	10	<u>10</u> .X00000
1000	1000	<u>10</u> XX.X000

Table 4-7. CONTROL SETTINGS FOR TRIP RANGE CHECK

- 4-47. MASTER REFERENCE. Proceed as follows:

- a. Set the front panel controls as follows:

POWER	ON
RANGE	1000
Readout Dials	00X.0000
VOLTAGE TRIP	1000
VERNIER	Maximum clockwise
CURRENT LIMIT	Maximum clockwise

- b. Connect a Model 895A to the MASTER REFERENCE test points through the top inner cover.
- c. Adjust CAL 1000V, CAL 100V and CAL 10V mechanically to mid-point of travel.
- d. Rotate the REF VOLTAGE ADJUST to obtain an indication of 15.00 volts (± 10 uV) on the Model 895A.
- e. Set the POWER switch to STDBY/RESET.

4-48. Voltage Standard Output

4-49. The voltage standard is calibrated by setting the zero output and adjusting the sample string resistors and the range resistors. Adjustment of sample string resistors determines output voltage ratio accuracy and adjustment of the range resistors determines absolute voltage accuracy. The linearization adjustment involves adjusting corresponding resistors in adjacent decades so they are in exact ten-to-one ratio with each other.

4-50. This procedure is divided into sections, initial and final. Both procedures are to be performed if any servicing has been done. The Final calibration need only be done if the instrument is operating normally and requires certification.

4-51. INITIAL CALIBRATION. The following adjustments should be performed whenever repairs have been made to the Model 332D. After completion, however, the adjustments given under Final Calibration must also be done.

4-52. The instrument should be warmed up for at least four hours at standard reference conditions of $23^{\circ}\text{C} \pm 1^{\circ}\text{C}$, up to 70% relative humidity and constant line voltage before adjustments are made. The instrument must be operated in its case with the RANGE switch and readout dials set for 100 volts output.

a. Set the Model 332D controls as follows:

POWER ON
 RANGE 1000
 Readout Dials 00X.0000
 VOLTAGE TRIP 1000
 VERNIER Maximum Clockwise
 CURRENT LIMIT Maximum Clockwise

b. Connect a Model 895A to the MASTER REFERENCE test points through the top inner cover.

c. Rotate the REF VOLTAGE ADJUST to obtain an indication of 15.0 volts ($\pm 10 \mu\text{V}$) on the Model 895A.

d. Connect a Model 845AR null detector across the OUTPUT terminals. Set the voltage standard dial readout to all zeros and the POWER switch to OPR.

e. At each RANGE switch position, vary the corresponding ZERO OUTPUT ADJUST (10V, 100V, 1000V) for a null indication ($\pm 2 \mu\text{volt}$) on the null detector.

f. Connect the 895A to the OUTPUT terminals of the 332D with the voltmeter common connected to the positive (+) output.

g. Set RANGE switch and decades on the 332D as listed in Table 4-8. Null the 895A reading or adjust the specified Sample String adjustment potentiometer.

h. Leave the 895A connected as in step f.

i. Set the RANGE and decades on the 332D as listed in Table 4-9. Adjust the 895A to 10.0 00 00 volts. Adjust the range calibration pots (CAL) shown in Figure 4-2 as required.

j. Set the Model 332D controls as follows:

POWER STDBY/RESET
 RANGE 10
 Readout Dials 5.000000
 VOLTAGE TRIP 1000
 VERNIER Maximum Clockwise
 CURRENT LIMIT Maximum Clockwise

Range	Dial Setting	Adjust 895A to:	Adjust *
1000	00 0X 00 0	Null Reading	--
1000	00 10 00 0	-----	1
1000	00 1X 00 0	Null Reading	--
1000	00 20 00 0	-----	2
1000	00 3X 00 0	Null Reading	--
1000	00 40 00 0	-----	4
1000	00 7X 00 0	Null Reading	--
1000	00 80 00 0	-----	8
} C Decade			
1000	00 X0 00 0	Null Reading	--
1000	01 00 00 0	-----	1
100	01 X0 00 0	Null Reading	--
100	02 00 00 0	-----	2
100	03 X0 00 0	Null Reading	--
100	04 00 00 0	-----	4
100	07 X0 00 0	Null Reading	--
100	08 00 00 0	-----	8
} B Decade			
100	0X 00 00 0	Null Reading	--
100	10 00 00 0	-----	1
10V	1X 00 00 0	Null Reading	--
10V	20 00 00 0	-----	2
10V	3X 00 00 0	Null Reading	--
10V	40 00 00 0	-----	4
10V	7X 00 00 0	Null Reading	--
10V	80 00 00 0	-----	8
} A Decade			

* Adjust the specified Sample String potentiometers to within $\pm 2 \mu\text{V}$ of the previous null reading.

Table 4-8. SAMPLE STRING PRE-LINEARIZATION

332D Range	332D Dial Setting	Adjust 895A To:	Adjust
10V	100 00 00 0	10.0 00 00	10V CAL to null
100V	10 00 00 0	10.0 00 00	100V CAL to null
1000V	01 00 00 0	10.0 00 00	1000V CAL to null

Table 4-9. PRELIMINARY RANGE CALIBRATION

k. Connect a 0 to 100 dc milliammeter across the OUTPUT terminals. Set the POWER switch to OPR.

l. Referring to Figure 4-2, adjust R23 for a 60 milli-ampere indication on the external meter.

m. Rotate the CURRENT LIMIT control maximum counter-clockwise. Adjust R24 for approximately 0.5 milliampere indication on the external meter.

n. If necessary, re-adjust R23 and R24 until the range of the CURRENT LIMIT control is from 0.5 to 60 milliamperes.

- o. Set the POWER switch to STDBY/RESET. Replace the top inner cover on the Model 332D.
- p. Set the METER switch to CURRENT and POWER switch to OPR.
- q. Adjust the CURRENT LIMIT control to obtain a 50 milliampere indication on the external meter.
- r. Rotate the adjustment labeled OUTPUT CURRENT METER ADJUST until the front-panel meter pointer indicates 50 milliamperes on the red scale.
- s. Set the RANGE switch to 100 volts; then to 1000 volts. The front-panel meter should indicate 50 milliamperes in each position of the RANGE switch.
- t. Set the POWER switch to STDBY/RESET. Remove the external meter connections from Model 332D.
- u. Set the Model 332D front panel controls as follows:

POWER	OPR
METER	VOLTAGE
RANGE	100
Readout Dials	<u>100.00000</u>
- v. Rotate the adjustment labeled OUTPUT VOLT-METER ADJUST until the front-panel meter indicates 100 volts ± 0.5 volts.
- w. Meter linearity may be checked at the cardinal points listed in Table 4-10. All full-scale meter indications should be within $\pm 3\%$ of full scale.

RANGE	READOUT DIALS
10	1.000000
100	10.00000
1000	100.0000
10	<u>10.000000</u>
1000	<u>1000.0000</u>

Table 4-10. CONTROL, SETTINGS FOR VOLTAGE MONITOR LINEARITY CHECK

- x. Set the Model 332D controls as follows:

RANGE	1000V
Readout Dials	125.0000
VOLTAGE TRIPOUT	Maximum Counter-
ADJUST (top cover)	clockwise
VOLTAGE TRIP	100
VERNIER	Fully Clockwise
- y. Rotate the VOLTAGE TRIPOUT ADJUST until the output is de-energized, as indicated by the illumination of the red indicator lamp and the audible "click" of relays.
- z. Set RANGE to 10 and reset the instrument.
- aa. Set the POWER switch to OPR. Set the RANGE switch, TRIP switch, and readout dials as listed in Table 4-11. Check the trip action on each range by rotating the VERNIER control counter-clockwise. The trip point should occur in each RANGE switch position when the VERNIER control is approximately 30° from the maximum clockwise position.

TRIP	RANGE	READOUT DIALS
10	10	<u>10.X00000</u>
1000	1000	<u>10XX.X000</u>

Table 4-11. CONTROL SETTINGS FOR TRIP RANGE CHECK

- ab. Set the output of the instrument for 4 volts on the 10 volt range. Set the VOLTAGE TRIP switch to the 10 volt position and the VERNIER control to the 12 o'clock position.
- ac. Set the RANGE switch to 100 volts. The trip circuit should actuate.
- ad. Set the VOLTAGE TRIP switch to the 100 volt position and reset the instrument.
- ae. Set the RANGE switch to the 1000 volt position. The trip circuit should actuate.
- af. Set the VOLTAGE TRIP switch to the 1000 volt position and the VERNIER maximum clockwise. Re-set the instrument.
- ag. Set the RANGE switch to 100 volts then to 10 volts. The trip circuit should not actuate in either position.

4-53. FINAL CALIBRATION. The following procedure should be performed to accomplish the final linearization of the Sample String and the Range Calibration on the 332D.

- a. Connect a Model 845AR null detector across the OUTPUT terminals. Set the voltage standard dial readout to all zeros and the POWER switch to OPR.
- b. At each RANGE switch position, vary the corresponding ZERO OUTPUT ADJUST (10V, 100V, 1000V) for a null indication (± 1 microvolt) on the voltmeter.
- c. Self-calibrate the 720A using the procedure contained in its instruction manual.
- d. Using the 7101B DC Voltage Calibration System make the equipment connections shown in Figure 4-3.
- e. Set the readout dials of the 720A to the standard cell voltage (e.g., “.1018000”).

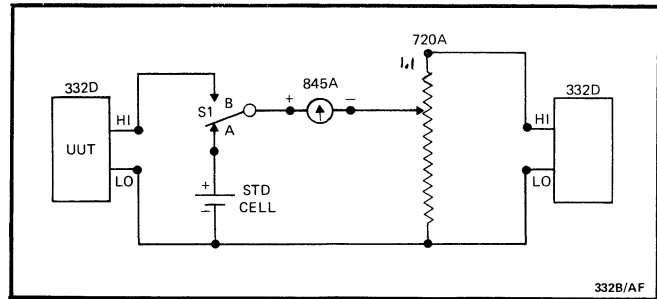

Figure 4-3. CONNECTIONS FOR SAMPLE STRING LINEARIZATION

- f. Set switch S1 to position A.
- g. Adjust the output of the 332D (approximately 11V) for a null indication (± 1 microvolt) on the 845AR.
- h. Set OPERATE switch on 845AR to zero. Set switch S1 to position B.
- i. Set the RANGE and readout dials to the values listed in Table 4-12 and adjust the RANGE CAL or SAMPLE STRING ADJUST potentiometers as indicated.

STEP	720 SETTING	332D RANGE	332D DIAL SETTING	NULL ADJUSTMENT	845AR NULL
1	0000000	1000V	000.0000	1 845AR	± 1 uV
2	.1000000	1000V	000.X000	1000V CAL	± 1 uV
3	.1000000	1000V	001.0000	DECK C - 1	± 1 uV
4	.2000000	1000V	002.0000	DECK C - 2	± 1 uV
5	.4000000	1000V	004.0000	DECK C - 4	± 2 uV
6	.8000000	1000V	008.0000	DECK C - 8	± 4 uV
7	1.0000000	1000V	00X.0000	2 720A	± 5 uV
8	Step 7 null	1000V	010.0000	DECK B - 1	± 5 uV
9	0000000	100V	00.00000	1 845AR	± 1 uV
10	.1000000	100V	01.00000	100V CAL	± 1 uV
11	.2000000	100V	02.00000	DECK B - 2	± 1 uV
12	.4000000	100V	04.00000	DECK B - 4	± 2 uV
13	.8000000	100V	08.00000	DECK B - 8	± 4 uV
14	1.0000000	100V	0X.00000	2 720A	± 5 uV
15	Step 14 null	100V	10.00000	DECK A - 1	± 5 uV
16	0000000	10V	0.000000	1 845AR	± 1 uV
17	.1000000	10V	1.000000	10V CAL	± 1 uV
18	.2000000	10V	2.000000	DECK A - 2	± 1 uV
19	.4000000	10V	4.000000	DECK A - 4	± 2 uV
20	.8000000	10V	8.000000	DECK A - 8	± 4 uV

1 Adjust the 845AR ZERO ADJ to obtain a system zero.

2 Adjust the 720A readout dials for a null on the 845AR. Retain this setting for the next step.

Table 4-12. FINAL LINEARIZATION OF DECK C, B AND A

- j. Repeat steps a. through h., paragraph 4-53.
- k. Set the RANGE and readout dials to the values listed in Table 4-13 and adjust the RANGE CAL potentiometers as indicated.
- NOTE!*
- The calibration of the 332B should now be checked to ensure that it meets the accuracy specifications.*
- l. Using the 7101B DC Voltage Calibration System make the equipment connections shown in Figure 4-4.
- m. Set the Standard cell voltage on the standard cell readout dials of the 750A.
- n. Set the instruments to the settings shown in step 1 of Table 4-14.
- o. Connect the 845AR across the output terminals of the 332D. The 845AR should read zero volts and be within the tolerance specified in Table 4-14.
- p. Connect the 845AR to test points A shown in Figure 4-4.
- q. Set the instruments to the settings shown in step 2 of Table 4-14.
- r. Switch in the null indicator with the switch on the 750A and adjust the output of the 332D for a null indication (± 1 microvolt) on the 845AR. The 332D should read ≈ 1100 volts.
- s. Connect the 845AR to test points B shown in Figure 4-4. The null indicator should read within the tolerance specified for this step in Table 4-14.
- t. Perform the remaining checks in Table 4-14 by setting the instruments as specified in each step and checking the specified tolerance against the 845AR null indicator. The steps that are marked with a flag should be performed as in instruction o. of this paragraph.

WARNING!

During this procedure high voltage is present at the terminals of all test instruments except the standard cell. When relocating the null indicator the output of the 332D should be set to zero volts.

720A SETTING	332D RANGE	332D DIAL SETTING	NULL ADJUSTMENT	845AR NULL
1.0000000	1000V	010.0000	1000V CAL	$\pm 5 \mu\text{V}$
1.0000000	100V	10.00000	100V CAL	$\pm 5 \mu\text{V}$
1.0000000	10V	<u>10.000000</u>	10V CAL	$\pm 5 \mu\text{V}$

Table 4-13. FINAL RANGE CALIBRATION

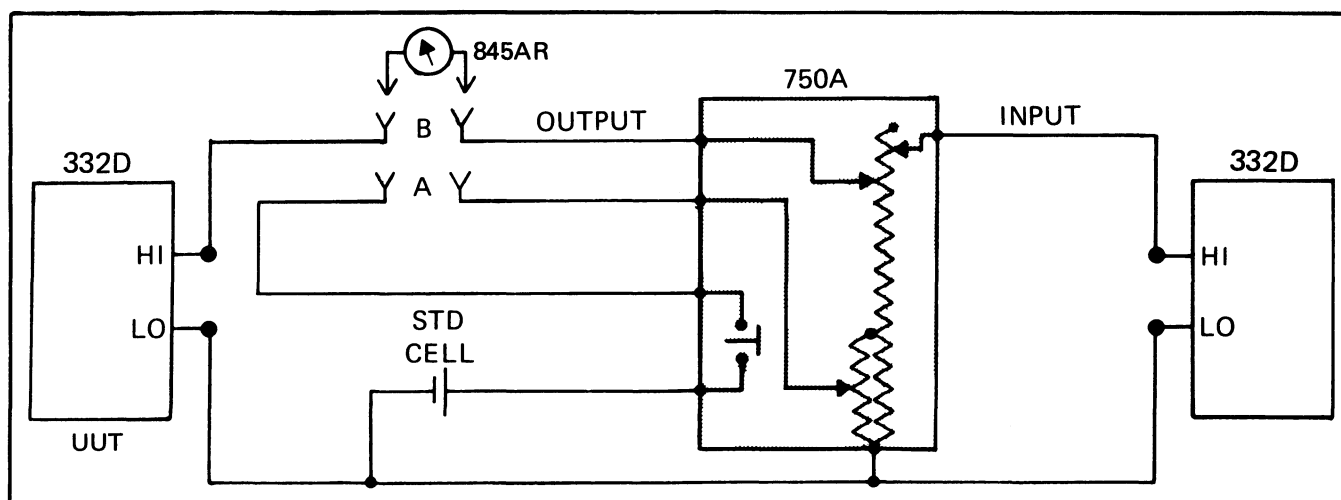

Figure 4-4. CONNECTIONS FOR RANGE CALIBRATION CHECKS

STEP	750A SETTING		332D		TOLERANCE
	INPUT	OUTPUT	RANGE	DIAL SETTING	
1	1	---	10V	0.000000	±10 µV
	2	1100	5	5.000000	±60 µV
	3	1100	10	10.000000	±110 µV
1	4	---	100V	00.000000	±20 µV
	5	1100	5	05.000000	±70 µV
	6	1100	10	10.000000	±120 µV
1	7	1100	50	50.000000	±520 µV
	8	1100	100	100.000000	±1020 µV
	9	---	1000V	000.000000	±200 µV
1	10	1100	5	005.000000	±275 µV
	11	1100	10	010.000000	±350 µV
	12	1100	50	050.000000	±950 µV
	13	1100	100	100.000000	±1700 µV
	14	1100	500	500.000000	±7.7 mV
	15	1100	1000	1000.000000	±15.2 mV
	16	1100	1100	1000.000000	±16.7 mV
	17	1100	1100	1099.999900	±16.7 mV

1 Perform this test as described in step o., paragraph 4-53.

Table 4-14. CONTROL SETTINGS AND TOLERANCES FOR CALIBRATION CHECK

4-54. TROUBLESHOOTING

4-55. A thorough understanding of the principles of operation is necessary to efficiently troubleshoot the instrument. It is recommended that Section 3 be reviewed before attempting to troubleshoot the unit.

4-56. The following troubleshooting procedure is in such sequence that it can be applied to any unit, including one in which the trouble is totally unknown and there is doubt whether power can be applied without causing damage. If the unit is operable, the Resistance Measurement and the Standby Power Check, Paragraphs 4-57 and 4-59 may be omitted. The checkout follows the guidelines listed below, and is intended to localize the trouble to an assembly which may be tested individually.

- a. Remove the Pre-Regulator P/C Assembly.
- b. Check all auxiliary supplies and the reference voltage.
- c. Check the Control Amplifier to ensure that it operates properly when provided with an error signal.
- d. Verify that the Pre-Regulator is being turned on and off by the Unijunction Oscillator.

When it can be verified that the Pre-Regulator is controlling power to the High Voltage Rectifier, the POWER switch may be set to the OPR position and the Series Pass Element checked.

WARNING !

The inner chassis is at the same potential as the +OUTPUT terminal. Avoid contact with the inner chassis and exposed parts. The Pre-Regulator circuitry is at line voltage above ground. When changing P/C boards, use the POWER switch OFF position and wait a few seconds after removing power to allow capacitors to discharge. When changing the Pre-Regulator Assembly, set the POWER switch to OFF.

4-57. Resistance Measurements

4-58. These checks verify correct output resistance of auxiliary voltage supplies. A check of the sample string may reveal an open resistor, which is sometimes a cause of loss of regulation. An ohmmeter (RCA VoltOhmyst or equivalent) is required for this test.

- a. Disconnect the instrument power plug from ac power. Disengage the chassis from the case by loosening the two Dzus fasteners on the rear of the instrument. Slide the unit out of the case and remove the top inner cover. This will open the interlock.
- b. Remove the Pre-Regulator P/C Assembly. Set the instrument POWER switch to OFF and set the front panel controls as follows:

POWER	OFF
METER	V
VOLTAGE RANGE	100V
VOLTAGE TRIP	1000V
VERNIER	Fully Clockwise (CW)
CURRENT LIMIT	Fully Clockwise (CW)
Decade Dials	50.00000

- c. Measure the resistance between the following test points and the +SENSE terminal. Connect the assembly to the mother board by using the extender card.

ASSEMBLY	PIN	RESISTANCE (Approx.)
Auxiliary Power Supply	9	8.4 kilohms
Auxiliary Power Supply	10	2.1 kilohms
Current Limiter	1	6.0 kilohms
Current Limiter	3	3.0 kilohms

- d. Disconnect the shorting links between the SENSE and OUTPUT terminals. Remove the Differential Amplifier Assembly and connect an ohmmeter between pin 5 of the Differential Amplifier socket and the negative SENSE terminal. The ohmmeter should indicate less than 0.5 ohm. Step each dial through its range; the resistance should increase according to the following table. Return each dial to zero after checkout.

NOTE!

This check detects gross errors only, such as an open resistor. Resistors are factory selected for accuracy and temperature coefficient.

READOUT DIAL	RESISTANCE INCREASE OHMS PER STEP
Seventh	0.1
Sixth	1.0
Fifth	10
Fourth	100
Third	1000
Second	10,000
First	100,000

- e. Reconnect the links between the SENSE and OUTPUT terminals and replace the Differential Amplifier Assembly.

4-59. Standby Power

4-60. This check measures power consumption in the STDBY/RESET mode. It reveals possible gross faults such as wiring errors or shorted components in the auxiliary power supply, voltage control circuitry and protection circuitry. A metered Variac and differential voltmeter are required for this test.

- a. Remove the top inner cover and the Pre-Regulator Assembly if not already accomplished.
- b. Connect the instrument through a Variac to a 115 volt, 60 Hz, power line with a wattmeter or ammeter in series between the Variac and the instrument. Set the Variac output to zero. Set the front panel controls as follows:



POWER	OFF
VOLTAGE RANGE	100
VOLTAGE TRIP	1000
VERNIER	maximum clockwise
CURRENT LIMIT	maximum clockwise
Readout Dials	50.00000

- c. Set the POWER switch to STDBY/RESET and slowly increase the output of the Variac to 115 volts. The CURRENT LIMIT and center decimal lights should come on and the time delay relay (A6-K2001) should operate. The wattmeter should indicate 30 to 40 watts power drain.

4-61. Auxiliary Supply Voltages

4-62. This procedure checks out the bias voltages, master reference voltage and the series pass element voltage.

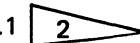
- a. Using the Model 895A differential voltmeter, measure the voltage between the test points listed in Table 4-15 and the +SENSE terminal, which is common.
- b. Where indicated, perform the adjustment to determine that it can be made. These should be re-checked during calibration of the instrument.

ASSEMBLY	PIN	VOLTS DC
Auxiliary Power Supply	10	23 to 27 
Auxiliary Power Supply	9	-14 to -16
Current Limiter	1	-33 to -39
Current Limiter	3	33 to 39
Range Cal	Test Points	14.9 to 15.1 
Reference Supply	Collector Q1	26 to 35 
Series Pass	Collector Q8	Approx. 140
Rear bulkhead power resistor, 100 kilohms	Yellow lead	650 to 725



	Adjustable to 25 volts \pm 10 mv with R9
	Adjustable to 15.0 volts \pm 10 uV with R9 on Reference Supply pcb
	Approximately 1 volt at turn-on, rising to 26 to 35 volts after 10 minute warm up.

Table 4-15. REFERENCE AND AUXILIARY VOLTAGES

4-63. Unijunction Oscillator and Chopper Amplifier

4-64. UNIJUNCTION OSCILLATOR. This check verifies operation of the unijunction oscillator and the flow of error signal through the chopper amplifier, differential amplifier and series pass driver. An oscilloscope is required for this test.

- Connect the oscilloscope with a 10X isolation probe between pins 14 (common) and 15 (input) of the Series Pass P/C Assembly. Set the oscilloscope sweep speed to 1 milliseconds/cm and vertical sensitivity to 1 volt/cm.
- Set the POWER switch to STDBY/RESET. Positive going pulses of 1.0 to 2.0 volts peak-to-peak should be observed.

4-65. CHOPPER AMPLIFIER. This procedure checks the alignment and response of the Chopper Amplifier in the 332D. An oscilloscope and a general purpose supply are required for this test. To check alignment:

- Install the Chopper Amplifier assembly on the extender card. Connect an oscilloscope to the base of Q3 on the Chopper Amplifier Board. The scope common should be connected to Pin 13 of the card connector. Connect a clip lead between Pin 6 and Pin 12 of the input connector.
- Turn the POWER switch to STDBY/RESET. Turn the CHOPPER DRIVE ADJUST (R43) to maximum clockwise. Turn CHOPPER COMPENSATION ADJUST to maximum clockwise.

- Adjust R34, CHOPPER COMPENSATION ADJUST for minimum pulse amplitude. The total adjustment range of R34 should provide a positive and negative pulse swing. If this is not satisfied, cut the jumper across R33 and again adjust R34. When correctly adjusted, R34 will reduce the positive spike at the transition point to zero.
- Alternately adjust R43 counter-clockwise and R34 as necessary to obtain maximum squareness of the chopper waveform without a spike at the transition point. When correctly adjusted, waveform should appear as shown in Figure 4-5.

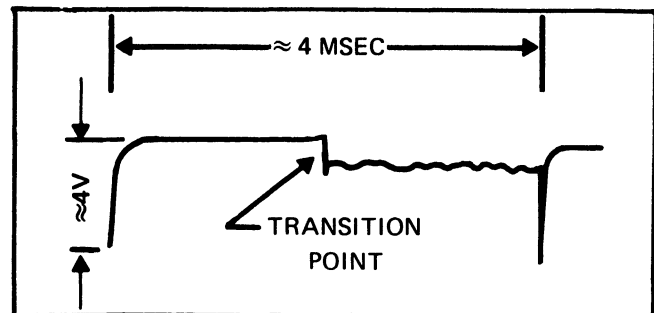

Figure 4-5. CHOPPER WAVEFORM

- Replace the chopper board in the instrument.
- 4-66. To check amplifier response:
- Connect the oscilloscope with a 10X isolation probe between Pins 14 (common) and 15 (input) of the Series Pass P/C Assembly. Set the oscilloscope sweep speed to 1 milliseconds/cm and vertical sensitivity to 1 volt/cm.

- b. Set the POWER switch to STDBY/RESET. Positive going pulses of 1.0 to 2.0 volts peak-to-peak should be observed.
- c. Set POWER switch to OPR position. The pulses observed in step b. should disappear.
- d. Set the output of a laboratory power supply to 5.5V dc.
- e. With 332D POWER switch in OPR position, connect the lab supply to the corresponding OUTPUT terminals of the 332D.
- f. Set 332D controls as follows and observe unijunction pulses:

Range	Dialed Voltage	Unijunction Pulses
10V	5.000000	Should appear
10V	6.000000	Should disappear
100V	05.00000	Should appear
100V	06.00000	Should disappear
1000V	005.0000	Should appear
1000V	006.0000	Should disappear

4-67. Pre-Regulator

4-68. This check verifies operation of the Pre-Regulator circuitry Q1 through Q8. An oscilloscope and power line isolation adapter are required for this test.

- a. Set the POWER switch to OFF. Install the pre-Regulator P/C Assembly.
- b. Set the instrument front panel controls as follows:

POWER	OFF
RANGE	1000
VOLTAGE TRIP	1000
VERNIER	Maximum Clockwise
CURRENT LIMIT	Maximum Clockwise

- c. Connect the oscilloscope power plug to the ac line via a line isolator (two-to-three wire adapter). The oscilloscope must be operated ungrounded when observing pre-regulator waveforms.
- d. Connect the oscilloscope common to the emitter of Q1 and connect the input to the base (Q1 is the stud-mounted power transistor). Set the vertical input to DC, sweep speed to 1 millisecond/cm and the vertical sensitivity to 0.5 volt/cm.

- e. Set the readout dials to 50.0000 and the POWER switch to STDBY/RESET. The oscilloscope waveform should appear as shown in Figure 4-6.
- f. Set the POWER switch to OPR. The oscilloscope waveform should appear as shown in Figure 4-7.
- g. Set POWER switch to STDBY/RESET and remove oscilloscope connections. Short out the interlocks using nylon blocks. Set POWER switch to OPR. Voltmeter of 332D should indicate 50 ± 10 volts.
- h. Set RANGE switch to 10 volt range. Voltmeter should indicate 5 ± 1 volt.
- i. Set RANGE switch to 1000 volt range. Voltmeter should indicate 500 ± 100 volts. Set POWER switch to OFF.

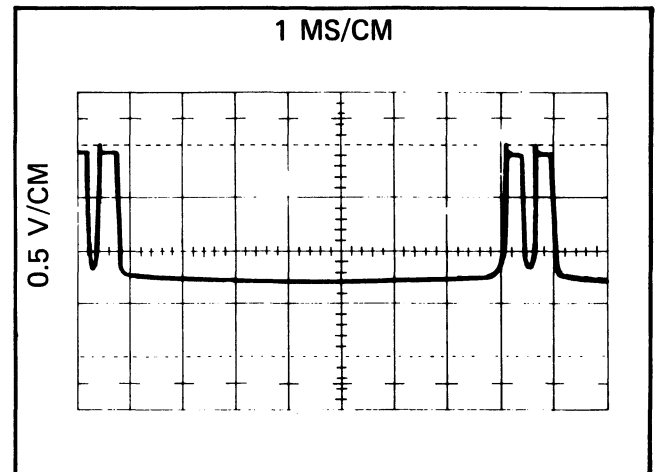

Figure 4-6. PRE-REGULATOR Q1, WAVEFORM ON STDBY/RESET

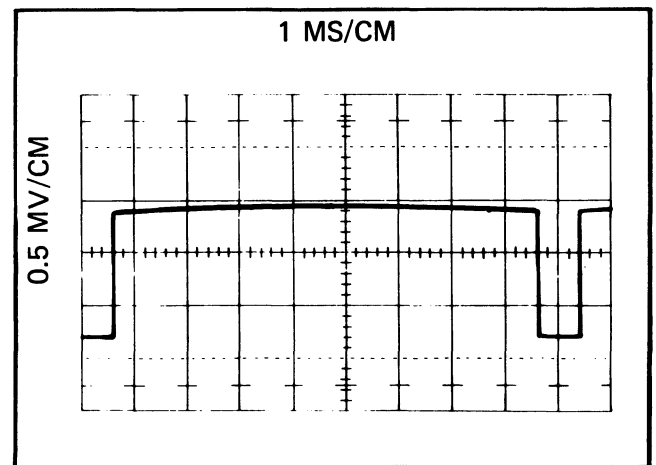

Figure 4-7. PRE-REGULATOR Q1, WAVEFORM ON OPR

- j. Connect the oscilloscope across the 50 watt zener diode on the pre-regulator assembly. Connect oscilloscope "positive" input to cathode; connect "negative" input to the anode; use a 10X probe. Connect output to load box.
- k. Set decades for 1100 volt output and set CURRENT LIMIT to 60 mA. Set POWER switch to OPR and apply full load, 60 mA.
- l. Set oscilloscope sensitivity to 50V/cm and sweep speed to 2 ms/cm.
- m. Set line voltage to 115V ac, 60 Hz. The waveform observed on the oscilloscope should appear as in Figure 4-8A and should not exceed 150 volts peak.
- n. Set line voltage to 100V ac, 60 Hz. The waveform observed on the oscilloscope should appear as in Figure 4-8B and should not exceed 150 volts peak.
- o. Set line voltage to 130V ac, 60 Hz. The waveform observed on the oscilloscope should appear as in Figure 4-8C and should not exceed 150 volts peak.
- p. Remove oscilloscope connections.

4-69. Series Pass Element

4-70. If the procedure has been completed satisfactorily thus far, the main parts of the voltage control circuitry have been checked out excluding the Series Pass P/C Assembly. A differential voltmeter and a load resistor box are required for this test.

- a. Set the line voltage to 100V ac and set readout dials to all zeros on 10 volt range. Connect a voltmeter between the collector of Q1 and the emitter of Q8 on the Pass Element Assembly. This voltage should read less than 2V dc.
- b. Set the line voltage and 332D controls as in Table 4-16 and measure the voltage between the collector and emitter of Q8. The voltages should be within the specified limits.
- c. Connect the voltmeter across the OUTPUT terminals of the 332D. Set the 332D for the following outputs on the 1000 volt range and short the OUTPUT terminals at each setting. The output should return to normal upon removal of the short.

OUTPUTS: 100, 300, 600, 900, 1100 volts.

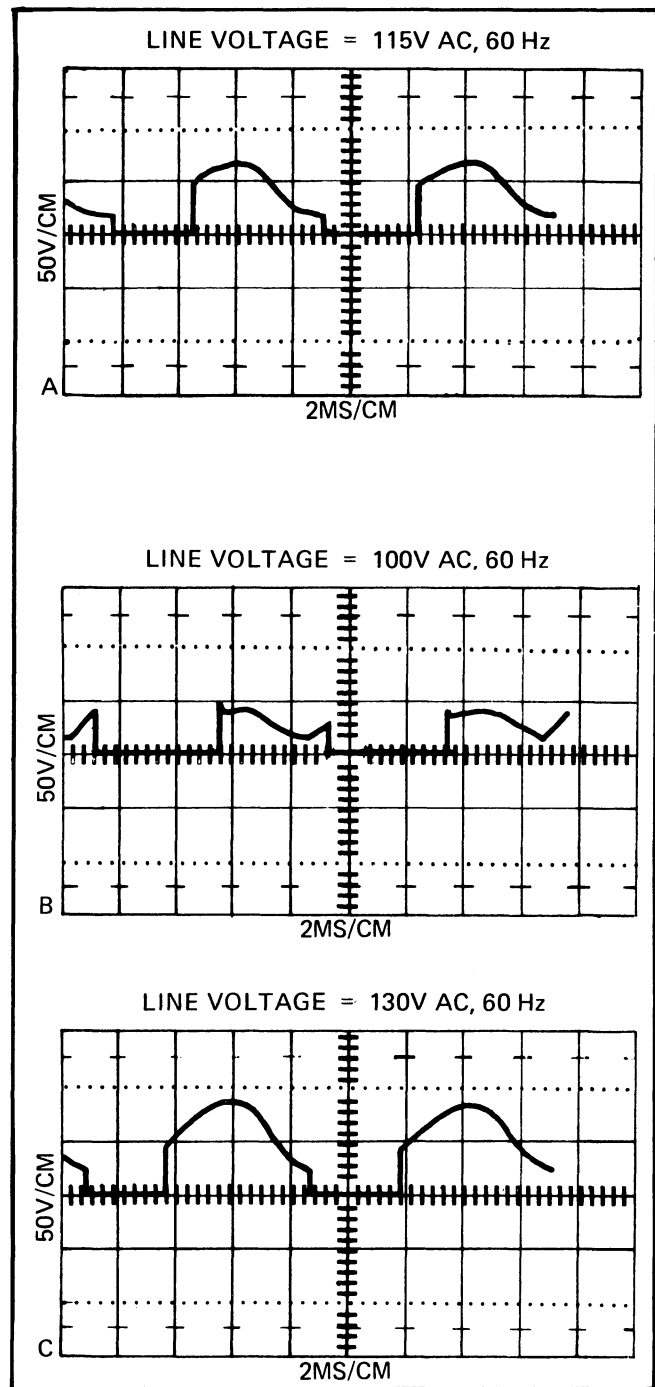

Figure 4-8. WAVEFORMS ACROSS ZENER DIODE

Range	Output	Load	Line Voltage	Voltage Limits Across Q8	
				Min.	Max.
10	0	0	100	45	100
10	0	0	130	45	90
1000	1100	60 mA	100	42	55
1000	1100	60 mA	130	42	55

Table 4-16. SERIES PASS ELEMENT VOLTAGE CHECKS

Section 5

Lists of Replaceable Parts

TABLE OF CONTENTS

REFERENCE DESIGNATOR	ASSEMBLY NAME/NUMBER	PART NO.	PAGE
	DC Voltage Standard Final Assembly (6160B)	6160B	5-3
A1	Capacitor P/C Assembly (332B-4055)	239343	5-10
A2	Sample String P/C Assembly (332B/AF-4051)	314849	5-11
A3	Capacitor/Switch P/C Assembly (335A-4092)	227603	5-14
A4	Range Calibration P/C Assembly (332B/AF-4052)	314856	5-15
A5	Mother Board P/C Assembly (335A-4064)	219238	5-17
A5A1	Reference Supply P/C Assembly (332B/AC-4083)	314864	5-19
A5A2	Series Pass Driver P/C Assembly (335A-4056)	219154	5-21
A5A3	Differential Amplifier P/C Assembly (335A-4057)	219162	5-23
A5A4	Chopper Amplifier Assembly (333A-4004)	251918	5-26
A5A5	Auxiliary Power Supply P/C Assembly (335A-4059)	219188	5-29
A5A6	Current Limiter P/C Assembly (335A-4060)	219196	5-33
A6	Time Delay P/C Assembly (332A-420)	192260	5-35
A7	High Voltage Mother Board P/C Assembly (332B-4056)	239350	5-37
A7A1	Series Pass Element P/C Assembly (332B-4061)	314823	5-39
A7A2	Preregulator P/C Assembly (332B-4082)	314815	5-41

5-1. INTRODUCTION

5-2. This section contains an illustrated parts breakdown of the instrument. Components are listed alpha-numerically by assembly. Electrical components are listed by reference designation and mechanical components are listed by item number. Each listed part is shown in an accompanying illustration.

5-3. Parts lists include the following information:

- a. Reference Designation or Item Number.
- b. Description of each part
- c. Fluke Stock Number.
- d. Federal Supply Code for Manufacturers. (See Appendix A for Code-to-Name list.)
- e. Manufacturer's part Number or Type.
- f. Total Quantity per assembly or component.
- g. Recommended Quantity: This entry indicates the recommended number of spare parts necessary to support one to five instruments for a period of two years. This list presumes an availability of common electronic parts at the maintenance site. For maintenance for one year or more at an isolated site, it is recommended that at least one in each assembly in the instrument be stocked. In the case of optional subassemblies, plug-ins, etc. that are not always part of the instrument, or are deviations from the basic instrument mode, the REC QTY column lists the recommended quantity of the item in that particular assembly.
- h. Use Code is provided to identify certain parts that have been added, deleted or modified during production of the instrument. Each part for which a use code has been assigned may be identified with a particular instrument serial number by consulting the Use Code Effectivity, paragraph 5-7.

the event the part you order has been replaced by a new or improved part, the replacement will be accompanied by an explanatory note and installation instructions, if necessary.

5-6. To ensure prompt and efficient handling of your order, include the following information.

- a. Quantity
- b. FLUKE Stock Number
- c. Description
- d. Reference Designation or Item Number
- e. Printed Circuit Board Part Number
- f. Instrument model and Serial number

5-7. USE CODE EFFECTIVITY LIST

USE	
CODE	SERIAL NUMBER EFFECTIVITY

5-4. HOW TO OBTAIN PARTS

5-5. Components may be ordered directly from the manufacturer by using the manufacturer's part number, or from the John Fluke Mfg. Co., Inc. factory or authorized representative by using the FLUKE STOCK NUMBER. In

REF DESIG	DESCRIPTION	STOCK NO	MFR	MFR PART NO	TOT QTY	REC QTY	USE CODE
	DC VOLTAGE STANDARD Figure 5-1	332D					
A1	Capacitor P/C Assembly (See Figure 5-2)	239343 (332B-4055)	89536	239343	1		
A2	Sample String P/C Assembly (See Figure 5-3)	314849 (332B/AF- 4051)	89536	314849	1	1	
A3	Capacitor Switch P/C Assembly (See Figure 5-4)	227603 (335A-4092)	89536	227603	1		
A4	Range Calibration P/C Assembly (See Figure 5-5)	314856 (332B/AF- 4052)	89536	314856	1		
A5	Main Mother Board P/C Assembly (See Figure 5-6)	219238 (335A-4064)	89536	219238	1		
A5A1	Reference Supply P/C Assembly (See Figure 5-7)	314864 (332B/AF- 4083)	89536	314864	1		
A5A2	Series Pass Driver P/C Assembly (See Figure 5-8)	219154 (335A-4056)	89536	219154	1		
A5A3	Differential Amplifier P/C Assembly (See Figure 5-9)	219162 (335A-4057)	89536	219162	1		
A5A4	Chopper Amplifier P/C Assembly (See Figure 5-10)	251918 (333A-4004)	89536	251918	1		
A5A5	Auxiliary Power Supply P/C Assembly (See Figure 5-11)	219188 (335A-4059)	89536	219188	1		
A5A6	Current Limiter P/C Assembly (See Figure 5-12)	219196 (335A-4060)	89536	219196	1		
A6	Time Delay P/C Assembly (See Figure 5-13)	192260 (332A-420)	89536	192260	1		
A7	High Voltage Mother Board P/C Assembly (See Figure 5-14)	239350 (332B-4056)	89536	239350	1		
A7A1	Series Pass Element P/C Assembly (See Figure 5-15)	314823 (332B/AF- 4061)	89536	314823	1		
A7A2	Preregulator P/C Assembly (See Figure 5-16)	314815 (332B/AF- 4082)	89536	314815	1		
A8	Extender P/C Board	187344 (332A-415)	89536	187344	1		
C1	Cap, oil, 4 uf \pm 10%, 1,200V	183541	01884	CMLE405K12	1		
C2	Cap, cer, 0.01 uf, gmV, 1,600V (located on C1)	106930	71590	DD16-103	2		

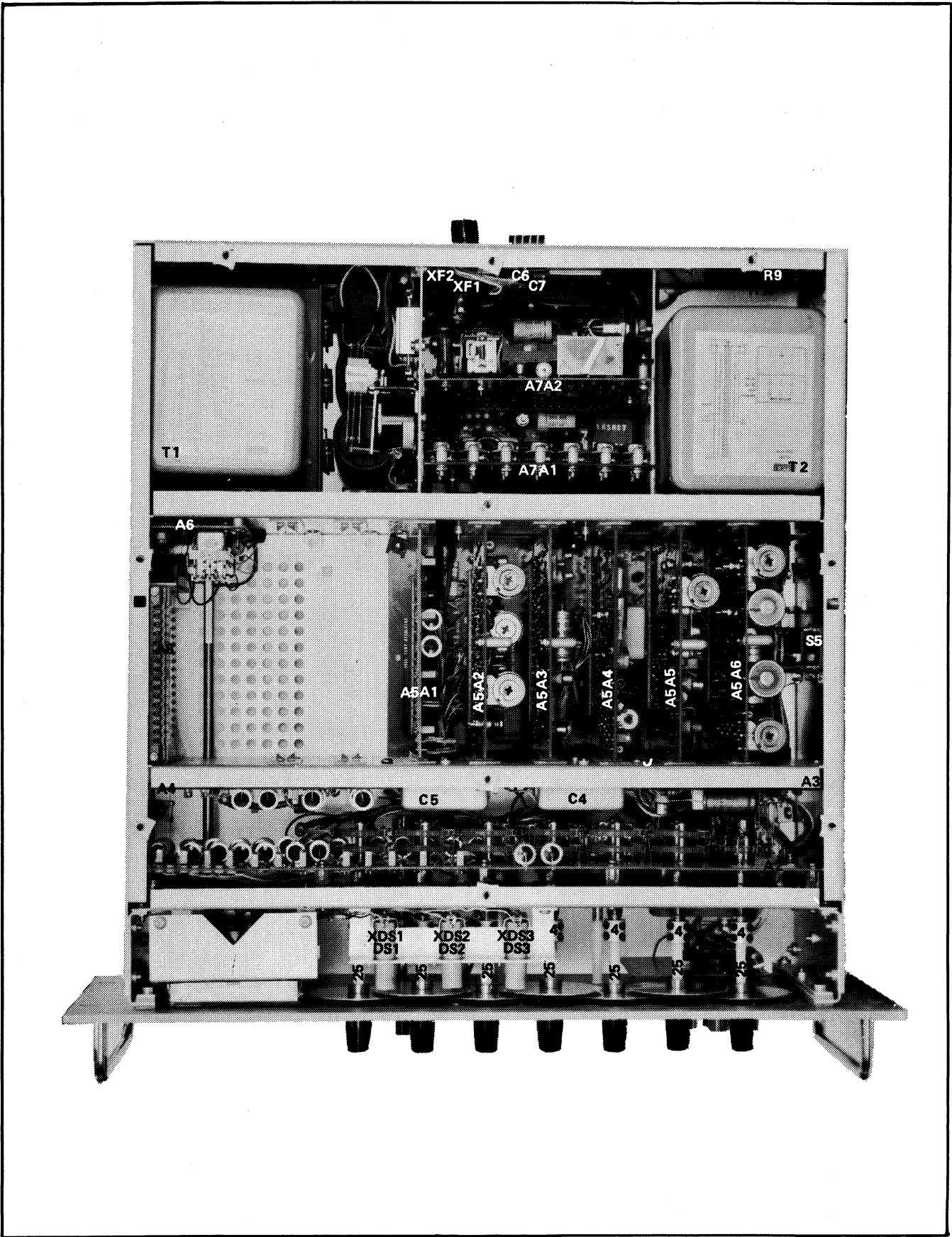

Figure 5-1. DC VOLTAGE STANDARD (Sheet 1 of 3)

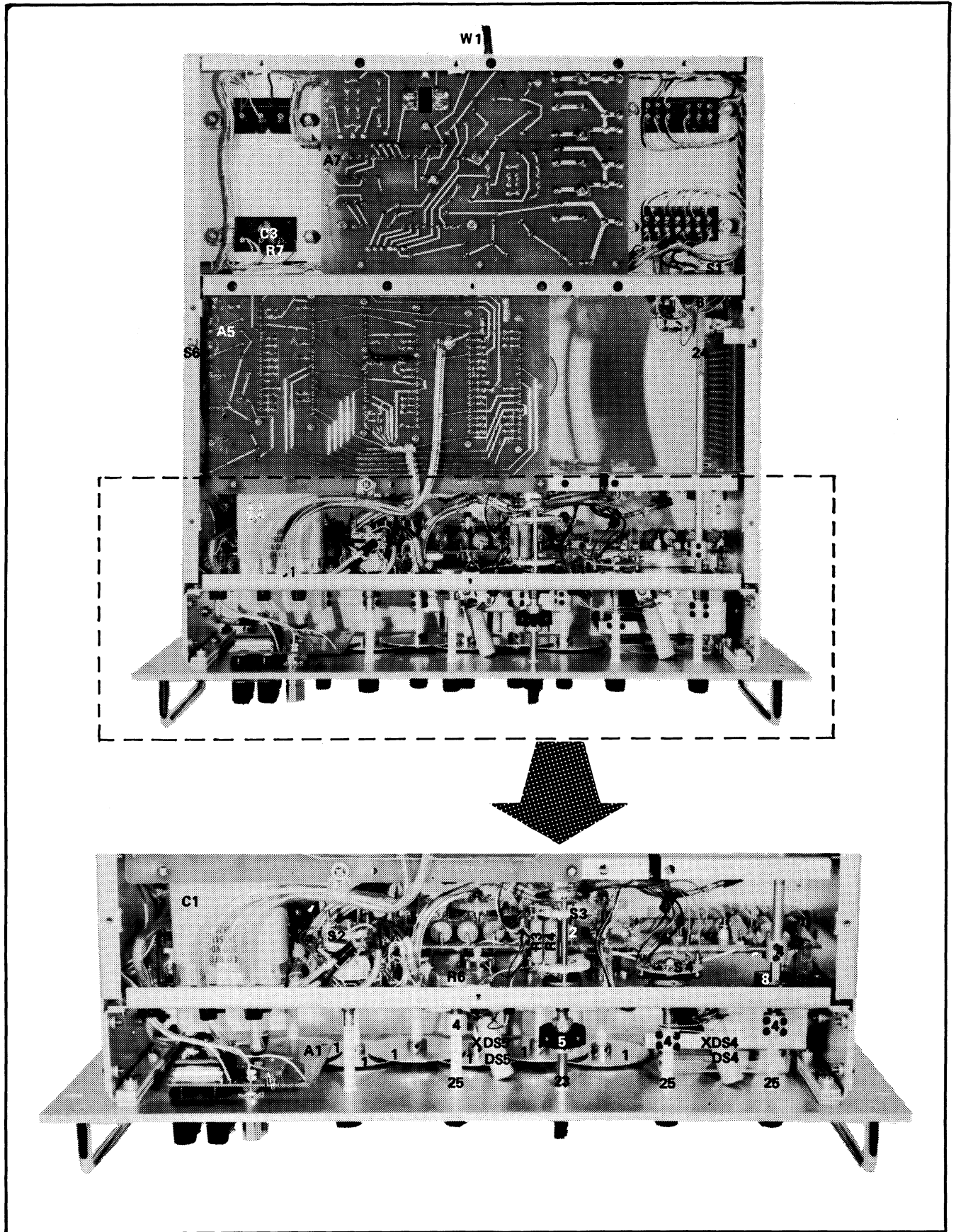

Figure 5-1. DC VOLTAGE STANDARD (Sheet 2 of 3)

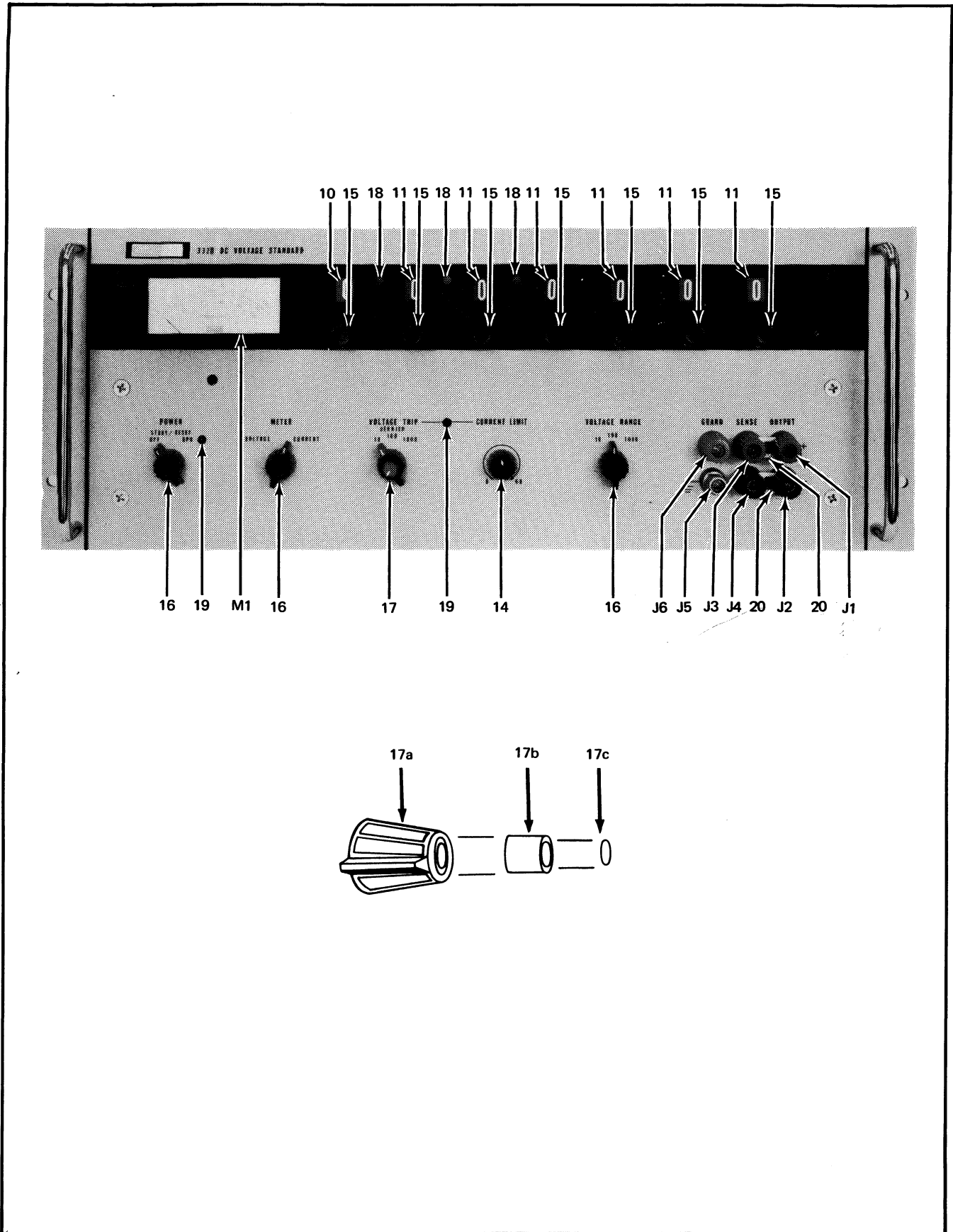

Figure 5-1. DC VOLTAGE STANDARD (Sheet 3 of 3)

REF DESIG	DESCRIPTION	STOCK NO	MFR	MFR PART NO	TOT QTY	REC QTY	USE CODE
C3	Cap, cer, 0.005 uf \pm 20%, 3,000V	188003	71590	DD30-502	1		
C4,C5	Cap, plstc, 0.1 uf \pm 10%, 1,500V	234260	96733	C-60232A	2		
C6, C7	Cap, poly, .10 uf \pm 10%, 400V	289744	73445	C280CFA100K	2		
CR1	Diode, silicon, 1 amp, 100 piv	116111	05277	1N4817	51	5	
CR2, CR3	Diode, silicon, 1 amp, 600 piv	112383	05277	1N4822	48	5	
CR4 thru CR8	Diode, light-emitting	309617	71318	FLV102	5		
F1	Fuse, Type MDL, slow blow, 1/4 amp, 250V	166306	71400	Type MDL	1	5	
F2	Fuse, Type MDA, slow blow, 3 amp, 250V (For 115V operation)	109280	71400	Type MDA	1	5	
F2	Fuse, Type MDX, slow blow, 1-1/2 amp, 250V (For 230V operation)	109231	71400	Type MDX	1	5	
J1	Binding post, red, OUTPUT	149856	58474	BHB10208G22	2		
J2	Binding post, black, OUTPUT	149864	58474	BHB10208G21	2		
J3	Binding post, red, SENSE	149856	58474	BHB10208G22	REF		
J4	Binding post, black, SENSE	149864	58474	BHB10208G21	REF		
J5	Binding post, GROUND	155911	58474	GP30NC	1		
J6	Binding post, blue, GUARD	233833	58474	DF31BLC	1		
K1	Relay, armature, 115 vac, dpdt	148940	73949	060713-00	1		
M1	Meter, 0-100 ua, 325 Ω	225490	89536	225490	1		
R1	Res, met flm, 100k \pm 1%, 1/2w (mounted on S3)	151316	75042	Type CEC-TO	2		
R2	Res, met flm, 1M \pm 1%, 1/2w (mounted on S3)	161075	75042	Type CEC-TO	1		
R3, R4	Res, car flm, 5M \pm 1%, 1w	107458	75042	Type C13	2		
R5	Res, var, ww, 5k \pm 10%, 5w (mounted on S3)	219758	71450	Type AW	1		
R6	Res, var, ww, 300 Ω \pm 10%, 5w	219741	71450	Type AW	1		
R7	Res, comp, 1k \pm 10%, 1/2w	108563	01121	EB1021	4		
R8	Res, ww, 500 Ω \pm 5%, 25w	183533	14193	Type MC250	1		

REF DESIG	DESCRIPTION	STOCK NO	MFR	MFR PART NO	TOT QTY	REC QTY	USE CODE
R9, R10	Res, ww, 100k \pm 1%, 10w	177121	14193	Type SP1127	2		
S1	Switch, POWER, STDBY/RESET wafer	187864	76854	Type HC	1		
	Switch, POWER, OPR wafer	187872	76854	248214HC	1		
S2	Switch, VOLTAGE RANGE, rotary	237305	89536	237205	1		
S3	Switch, VOLTAGE TRIP, rotary	240739	89536	240739	1		
S4	Switch, METER, rotary	187146	89536	187146	1		
S5, S6	Switch, interlock	187708	91929	V3L-78	2		
T1	Transformer, power	222315	89536	222315	1		
T2	Transformer, high voltage	222307	89536	222307	1		
W1	Line cord	102822	89536	102822	1		
XF1, XF2	Holder, fuse	160846	75915	342004	2		
1	Coupler, dial	130252	89536	130252	7		
2	Coupler, R5 to S3	193557	89536	193557	1		
3	Coupler, Digit Switches to detents	226779	89536	226779	7		
4	Coupler, Digit Switches, S1, S4, R6	104505	89536	104505	11		
5	Coupler, S3	246058	89536	246058	1		
6	Coupler, S1 shaft to S1 wafer	200592	89536	200592	1		
7	Cover (not illustrated)	228809	89536	228809	1		
8	Detent, S1	240895	89536	240895	1		
9	Detent, Digit Switches	240887	89536	240887	7		
10	Dial, 0-10	226993	89536	226993	1		
11	Dial, 0-X	226985	89536	226985	6		
12	Foot, rubber (not illustrated)	103309	77969	9102W	4		
13	Handle, chrome plated brass	101717	05704	807	2		
14	Knob, CURRENT LIMIT	190249	89536	190249	1		
15	Knob, DIGITS 1-7	158949	89536	158949	7		

REF DESIG	DESCRIPTION	STOCK NO	MFR	MFR PART NO	TOT QTY	REC QTY	USE CODE
16	Knob, METER, POWER, VOLTAGE RANGE	158956	89536	158956	3		
17	Knob, VOLTAGE TRIP						
17a	Concentric	162347	89536	162347	1		
17b	vernier	241018	89536	241018	1		
17c	trim disc	236950	89536	236950	1		
18	Lens, decimal, clear	222596	89536	222596	3		
19	Lens, decimal, red	228056	89536	228056	2		
20	Link, shorting, copper	190728	24655	938LG	2		
21	Panel, front	228775	89536	228775	1		
22	Shaft, S3 (not illustrated)	227272	89536	227272	1		
23	Shaft, S3 to front panel	240879	89536	240879	1		
24	Shaft, S1	239392	89536	239392	1		
25	Shaft, Digit Switches, S1, S4, R6	226928	89536	226928	10		

REF DESIG	DESCRIPTION	STOCK NO	MFR	MFR PART NO	TOT QTY	REC QTY	USE CODE
A1	CAPACITOR P/C ASSEMBLY Figure 5-2	239343 (332B-4055)	89536	239343	REF		
C1, C2	Cap, plstc, 1 uf ±20%, 250V	190330	73445	C280AE/ PIM	2		
CR1, CR2	Diode, silicon, 1 amp, 100 piv	116111	05277	1N4817	REF		

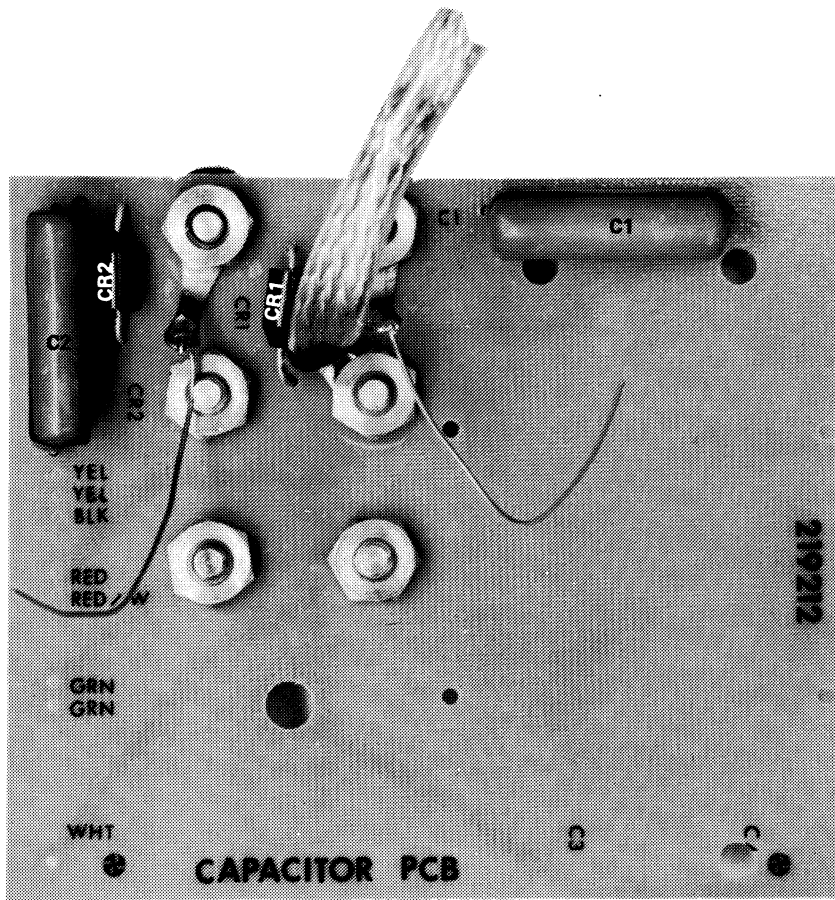











Figure 5-2. CAPACITOR PRINTED CIRCUIT ASSEMBLY

REF DESIG	DESCRIPTION	STOCK NO	MFR	MFR PART NO	TOT QTY	REC QTY	USE CODE
A2	SAMPLE STRING P/C ASSEMBLY Figure 5-3	314849 (332B/AF- 4051)	89536	314849	REF		
R1, R2	Res, met flm, $34\Omega \pm 1\%$, 1/8w	296699	91637	TYPE MFF1/8	2		
R3, R4	Res, met flm, $20\Omega \pm 1\%$, 1/8w	236844	91637	TYPE MFF1/8	2		
R5, R6	Res, var, cer met $50\Omega \pm 20\%$, 1/2w	267815	71450	190PC500B	2		
R7, R8, R9,R10, R11,R12	Res, var, cer met $20\Omega \pm 20\%$, 1/2w	261180	71450	190PC200B	6		
R13 thru R24	Res, met flm, $10\Omega \pm 1\%$, 1/8w	268789	91637	TYPE MFF1/8	12		
R25	Res, 997.5 Ω , matched set		89536		1		
R26	Res, 1996.5 Ω , matched set				1		
R27,R28	Res, 3.995k, matched set		89536		2		
R29 thru R35	Res, 19.985k, matched set		89536		7		
R36 thru R46	Res, 99.925k, matched set		89536		11		
R47	Res, var, cer met, $100\Omega \pm 20\%$, 1/2w	267823	71450	190PC101B	1		
R48	Res, var, cer met, $200\Omega \pm 20\%$, 1/2w	284711	71450	190PC201B	1		
R49,R50	Res, var, cer met, $500\Omega \pm 20\%$, 1/2w	267849	71450	190PC501B	2		
R51	Res, met flm, $100\Omega \pm 1\%$, 1/8w	168195	91637	TYPE MFF1/8	1		
R52	Res, met flm, $200\Omega \pm 1\%$, 1/8w	245340	91637	TYPE MFF1/8	1		
R53, R54	Res, met flm, $348\Omega \pm 1\%$, 1/8w	236778	91637	TYPE MFF1/8	2		
R55	Res, ww, $2\Omega \pm 0.2\%$, 1/10w	131870	89536	131870	1		
R56	Res, ww, $1\Omega \pm 2\%$, 1/10w	131888	89536	131888	1		
R57, R58	Res, ww, $4\Omega \pm .015\%$, 1/4w	313809	89536	313809	2		
R59	Res, ww, $10\Omega \pm 9\%$, 1/2w	155879	89536	155879	1		
R60	Res, ww, $20\Omega \pm 5\%$, 1/2w	155887	89536	155887	1		
R61,R62	Res, ww, 40Ω , 1/2w	158022	89536	158022	2		
R63	Res, ww, $100\Omega \pm 0.15\%$, 1/2w	155846	89536	155846	1		
R64	Res, ww, $200\Omega \pm 0.15\%$, 1w	131656	89536	131656	1		

REF DESIG	DESCRIPTION	STOCK NO	MFR	MFR PART NO	TOT QTY	REC QTY	USE CODE
R65, R66	Res, ww, 400Ω ±0.25%, 1/2w	131698	89536	131698	2		
S1 thru S6	Switch, rotary, sample string	313023	76854	249	6		
S7	Switch, assembly, seventh decade (R67 thru R76 included)	291021	89536	291021	1		

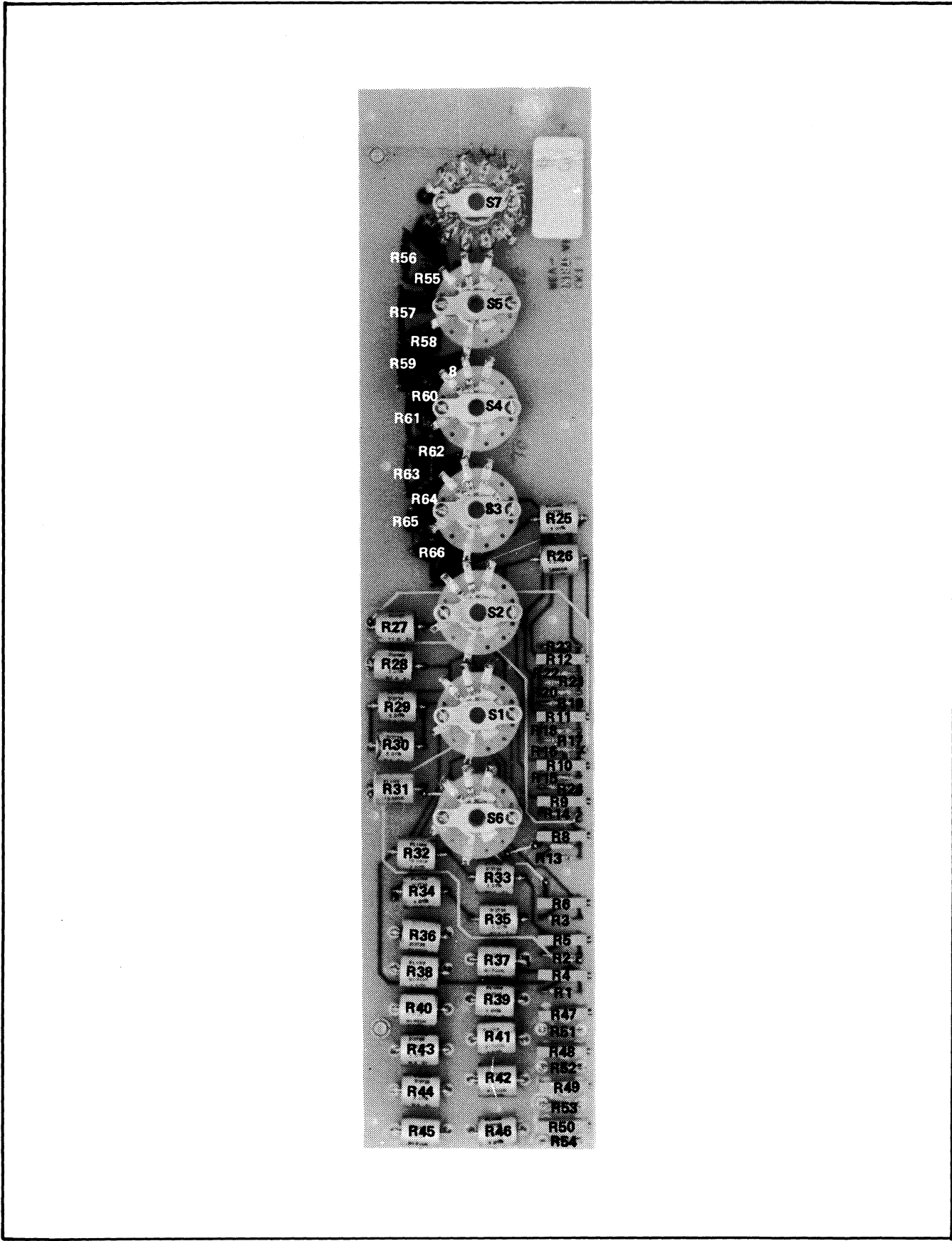

Figure 5-3. SAMPLE STRING PRINTED CIRCUIT ASSEMBLY

REF DESIG	DESCRIPTION	STOCK NO	MFR	MFR PART NO	TOT QTY	REC QTY	USE CODE
A3	CAPACITOR SWITCH P/C ASSEMBLY Figure 5-4	227603 (335A-4092)	89536	227603	REF		
C1	Cap, elect, 400 uf +50/-10%, 25V	168153	73445	C437ARF400	1	1	
CR1	Diode, silicon, 1 amp, 100 piv	116111	05277	1N4817	REF		
K1	Relay, reed, 1,000V Coil, reed relay, 24V	233916 186155	12617 71707	Type DRR-5 SP-24-P	1 4		
Q1	Tstr, silicon, NPN	203489	07910	CDQ10656	17	5	
R1, R6	Res, comp, 100Ω ±10%, 1/2w	108100	01121	EB1011	2		
R2	Res, comp, 15k ±10%, 1/2w	108530	01121	EB1531	2		
R3	Res, comp, 470Ω ±10%, 1/2w	108415	01121	EB4711	2		
R4	Res, comp, 10k ±10%, 1/2w	108118	01121	EB1031	4		
R5	Res, comp, 1k ±10%, 1/2w	108563	01121	EB1021	REF		
R7	Res, comp, 39k ±5%, 1w	236729	01121	GB3935	1		

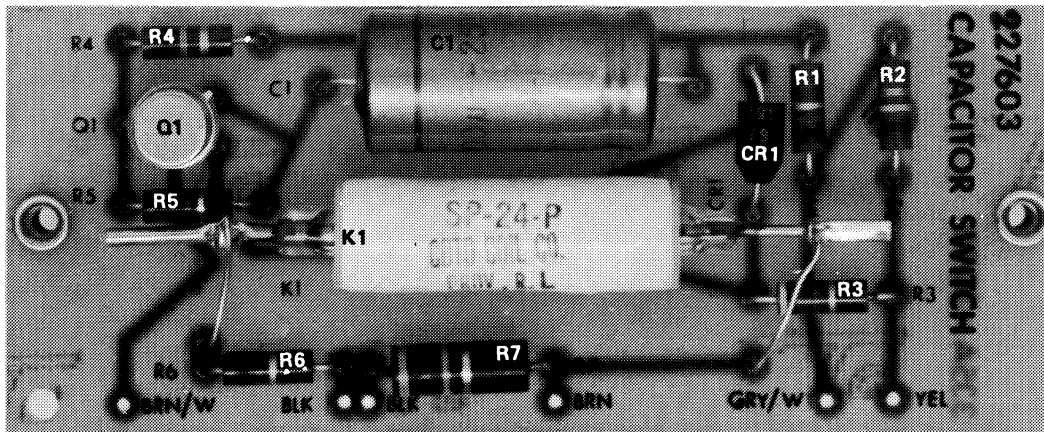

Figure 5-4. CAPACITOR SWITCH PRINTED CIRCUIT ASSEMBLY

REF DESIG	DESCRIPTION	STOCK NO	MFR	MFR PART NO	TOT QTY	REC QTY	USE CODE
A4	RANGE CALIBRATION P/C ASSEMBLY Figure 5-5	314856 (332B/AF-4052)	89536	314856	REF		
R1	Res, var, cer met, 20Ω ±20%, 1/2w	261180	71450	190PC200B	1		
R2, R3	Res, ww, 7.492k, matched set	1	89536	1	2		
R4	Res, met flm, 20Ω ±1%, 1/2w	296350	91637	TYPE MFF1/8	1		
R5	Res, var, cer met 200Ω ±20%, 1/2w	284711	71450	190PC201B	1		
R6, R7	Res, ww, 74.925k, matched set	1	89536	1	2		
R8	Res, met flm, 200Ω ±1%, 1/2w	151480	91637	TYPE MFF1/8	1		
R9	Res, var, cer met, 2k ±20%, 1/2w	267864	71450	190PC202B	1		
R10, R11	Res, ww, 749.25k, matched set	1	89536	1	2		
R12	Res, met flm, 2k ±1%, 1/2w	151266	91637	TYPE MFF1/2	1		
T1	Test point, red	170480	74970	105-752	1		
T2	Test point, black	149112	74970	105-0753	1		



Factory matched for resistance accuracy and temperature coefficient. When ordering, include all information stamped on the resistor (if not legible include information on adjacent resistors) in addition to the information requested in paragraph regarding obtaining parts.

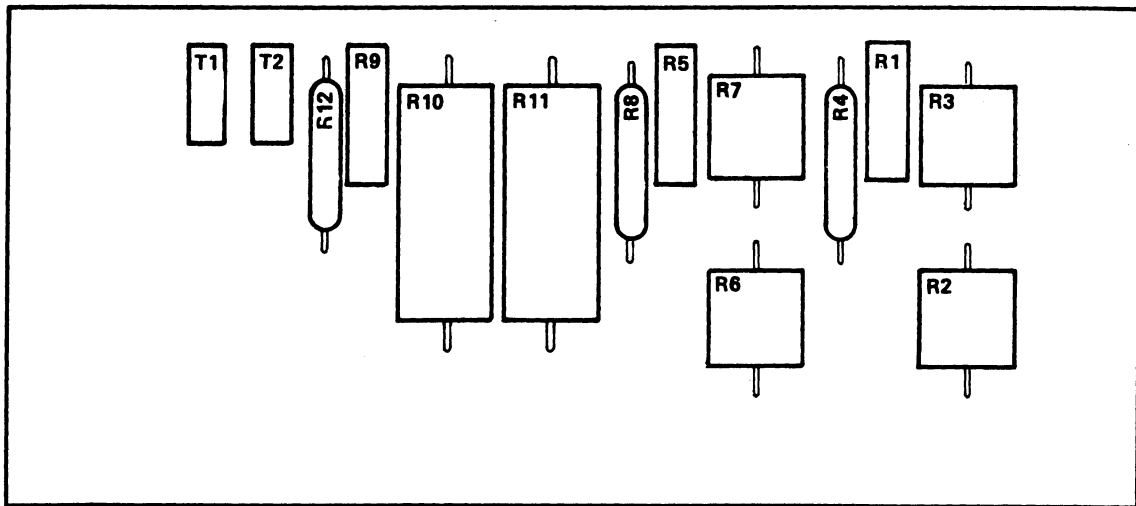

Figure 5-5. RANGE CALIBRATION PRINTED CIRCUIT ASSEMBLY

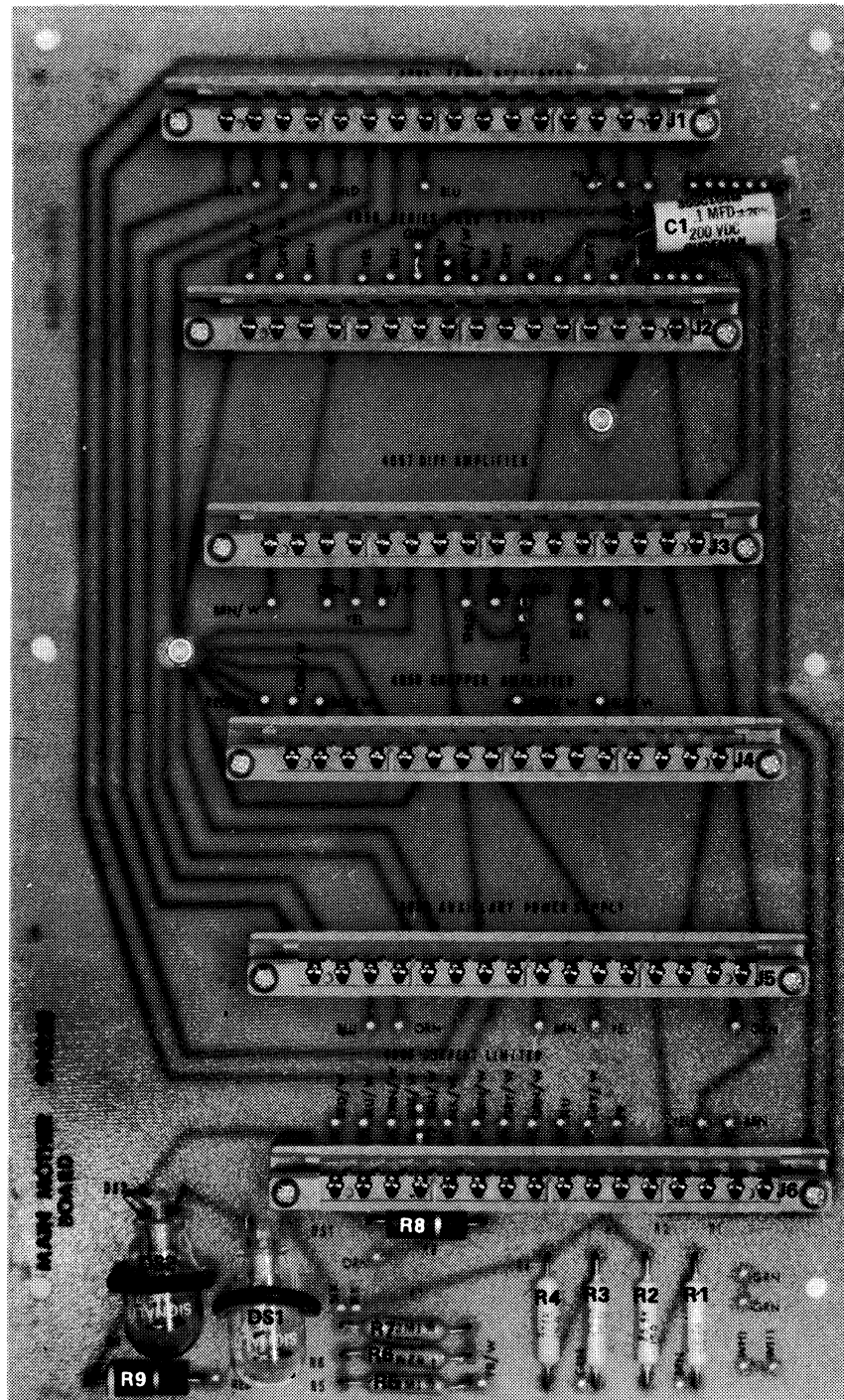

Figure 5-6. MAIN MOTHER BOARD PRINTED CIRCUIT ASSEMBLY

REF DESIG	DESCRIPTION	STOCK NO	MFR	MFR PART NO	TOT QTY	REC QTY	USE CODE
A5	MAIN MOTHER BOARD P/C ASSEMBLY - Figure 5-6	219238 (335A-4064)	89536	219238	REF		
C1	Cap, plstc, 0.1 uf $\pm 20\%$, 200V	106435	56289	192P10402	3		
DS1, DS2	Lamp, neon	185017	74276	NE-7	2	5	
R1	Res, met flm, 23.7k $\pm 1\%$, 1/2w	169383	75042	Type CEC-TO	2		
R2	Res, met flm, 25.5k $\pm 1\%$, 1/2w	219006	75042	Type CEC-TO	1		
R3	Res, met flm, 267k $\pm 1\%$, 1/2w	218990	75042	Type CEC-TO	1		
R4	Res, met flm, 274k $\pm 1\%$, 1/2w	218982	75042	Type CEC-TO	1		
R5 thru R7	Res, car flm, 1.82M $\pm 1\%$, 1/2w	219089	75042	Type C12	3		
R8	Res, comp, 1k $\pm 10\%$, 1w	109371	01121	GB1021	1		
R9	Res, comp, 470 Ω $\pm 10\%$, 1w	109710	01121	GB4711	1		
J1 thru J6	Connector, female, 16 contact	187732	91662	00-5009-016- 153-001	8		

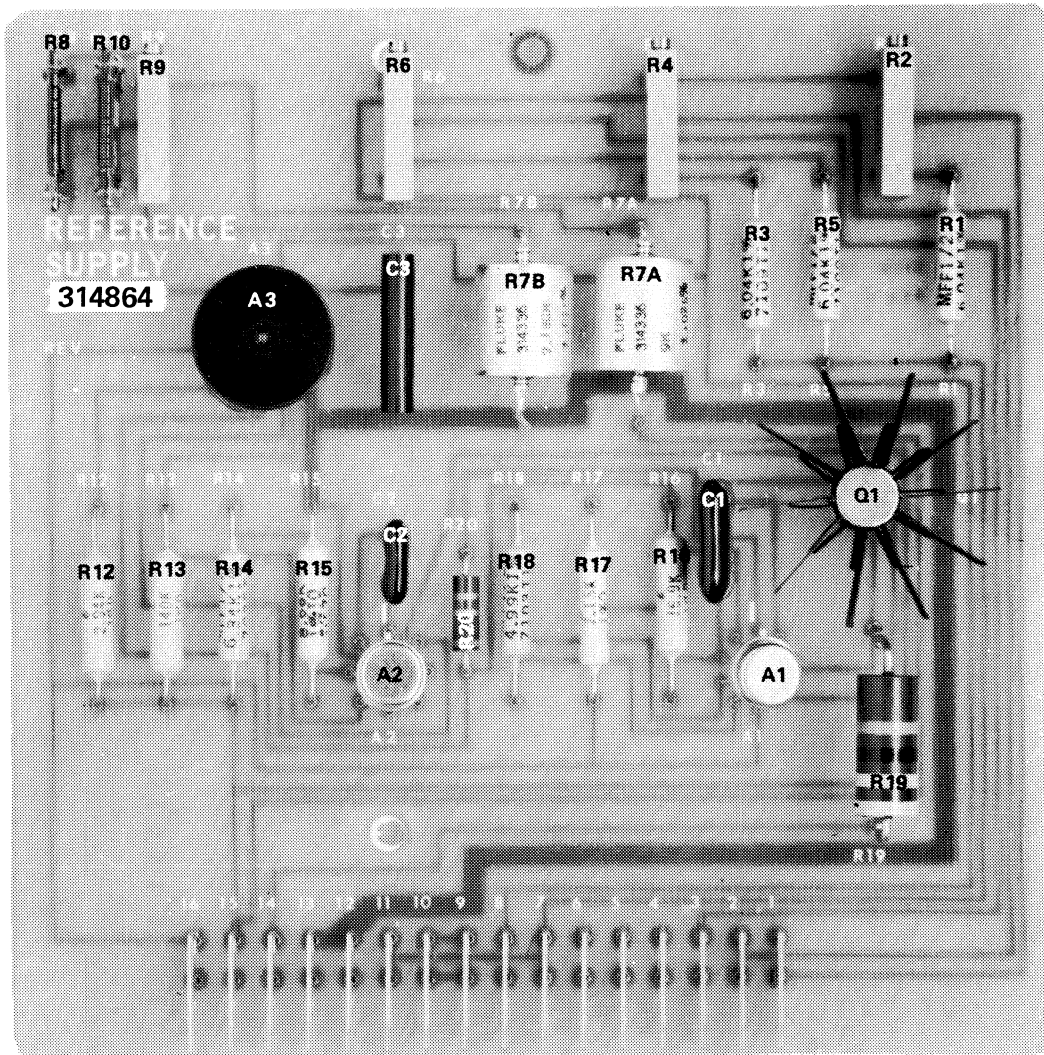

Figure 5-7. REFERENCE SUPPLY PRINTED CIRCUIT ASSEMBLY

REF DESIG	DESCRIPTION	STOCK NO	MFR	MFR PART NO	TOT QTY	REC QTY	USE CODE
A5A1	REFERENCE SUPPLY P/C ASSEMBLY Figure 5-7	314864 (332B/AF- 4083)	89536	314864	REF		
A1	IC, Operational amplifier	313106	MOTO- ROLA	MC1723CG	1		
A2	IC, Operational amplifier	271502	12040	LM301A	1		
A3	Ref amp with oven	248914	01295	4ST1-2	1		
C1	Cap, mica, 510 pf $\pm 5\%$, 500V	148411	14655	CD19F511J	1		
C2	Cap, mica, 27 pf $\pm 5\%$, 500V	177998	14655	CD15F221J	1		
C3	Cap, plstc, 0.1 uf $\pm 10\%$, 50V	271866	06001	75F2R5A104	1		
Q1	Tstr, Si, NPN	203489	07910	CDQ10656	1		
R2, R4, R6	Res, var, cer met, 10k $\pm 20\%$, 1/2w	267880	71450	190PC103B	3		
R7A, R7B, R13	Res, ref amp, matched set (R7A is always 9k res)	314971	89536	314971	1		
R8, R10	Res, ww, 50 Ω $\pm 0.06\%$, 1/2w	238493	89536	238493	2		
R9	Res, var, cer met 50 Ω $\pm 20\%$, 1/2w	267815	71450	190PC500B	1		
R11	Not used						
R12	Res, met flm, 2.94k $\pm 1\%$, 1/2w	247528	91637	TYPE MFF1/2	1		
R14	Res, met flm, 6.34k $\pm 1\%$, 1/2w	218636	91637	TYPE MFF1/2	1		
R15	Res, met flm, 8.66k $\pm 1\%$, 1/2w	247957	91637	TYPE MFF1/2	1		
R16	Res, met flm, 16.9k $\pm 1\%$, 1/2w	198275	91637	TYPE MFF1/2	1		
R17	Res, met flm, 7.15k $\pm 1\%$, 1/2w	186072	91637	TYPE MFF 1/2	1		
R18	Res, met flm, 4.99k $\pm 1\%$, 1/2w	148890	74970	105-0753	1		
R19	Res, comp, 33 Ω $\pm 5\%$, 2w	161497	01121	HB3305	1		
R20	Res, comp, 1.5 Ω $\pm 5\%$, 1/2w	246793	01121	EB15G5	1		

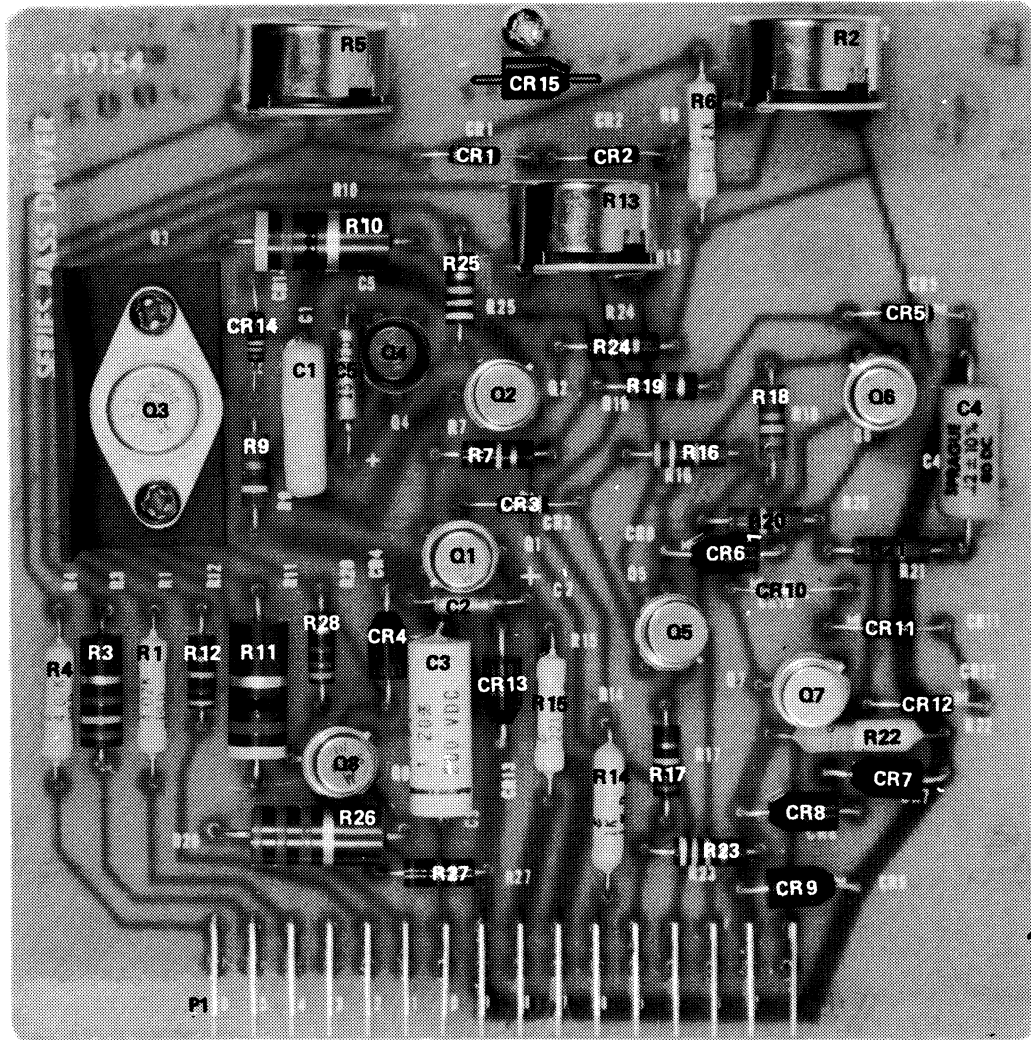

Figure 5-8. SERIES PASS DRIVER PRINTED CIRCUIT ASSEMBLY

REF DESIG	DESCRIPTION	STOCK NO	MFR	MFR PART NO	TOT QTY	REC QTY	USE CODE
A5A2	SERIES PASS DRIVER P/C ASSEMBLY - Figure 5-8	219154 (335A-4056)	89536	219154	REF		
C1	Cap, plstc, 0.47 uf \pm 20%, 250V	184366	73445	C280AE/P470	1		
C2	Cap, Ta, 2.2 uf \pm 10%, 20V	160226	05397	K2R2C20K	1		
C3	Cap, plstc, 0.1 uf \pm 20%, 200V	106435	56289	192P10402	REF		
C4	Cap, plstc, 0.22 uf \pm 10%, 80V	159392	56289	192P2249R8	1		
C5	Cap, Ta, 15 uf \pm 10%, 20V	153056	05397	K15C20K	2		
CR1, CR2, CR4, CR6 thru CR9, CR13, CR15	Diode, silicon, 1 amp, 100 piv	116111	05277	1N4817	REF		
CR3, CR5	Diode, zener, 10v	113324	07910	1N961A	2	1	
CR10, CR11, CR12	Diode, silicon, 150 ma, 6 piv	113308	07910	CD13161	3		
CR14	Diode, zener, 4.3V	180455	07910	1N749A	1	1	
P1	Connector, male, 16 contact	187724	91662	02-016-013- 5-200	REF		
Q1, Q4 Q6, Q8	Tstr, tested, silicon, PNP	159491	89536	159491	11	2	
Q2, Q5, Q7	Tstr, silicon, NPN	203489	07910	CDQ10656	REF		
Q3	Tstr, silicon, NPN	183004	95303	40250	1		
R1, R4	Res, met flm, 4.02k \pm 1%, 1/2w	167478	75042	Type CEC-TO	2		
R2	Res, var, ww, 2k \pm 10%, 1-1/4w	198416	71450	Type 110	1		
R3	Res, comp, 2.7k \pm 10%, 1w	109496	01121	GB2721	1		
R5, R13	Res, var, ww, 3k \pm 20%, 1-1/4w	149781	71450	Type 110	2		
R6	Res, met flm, 5.62k \pm 1%, 1/2w	219014	75042	Type CEC-TO	1		
R7	Res, comp, 100k \pm 10%, 1/2w	108126	01121	EB1041	3		
R9	Res, comp, 2.4k \pm 5%, 1/2w	108902	01121	EB2425	1		
R10, R11	Res, comp, 47 Ω \pm 10%, 2w	144352	01121	HB4701	2		

REF DESIG	DESCRIPTION	STOCK NO	MFR	MFR PART NO	TOT QTY	REC QTY	USE CODE
R12	Res, comp, 36k \pm 5%, 1/2w	185991	01121	EB3635	4		
R14	Res, met flm, 1k \pm 1%, 1/2w	151324	75042	Type CEC-TO	1		
R15	Res, met flm, 221k \pm 1%, 1/2w	182527	75042	Type CEC-TO	3		
R16	Res, comp, 3.9k \pm 10%, 1/2w	161406	01121	EB3921	1		
R17	Res, comp, 20k \pm 5%, 1/2w	109041	01121	EB2035	3		
R18	Res, comp, 16k \pm 5%, 1/2w	159632	01121	EB1635	3		
R19	Res, comp, 10k \pm 10%, 1/2w	108118	01121	EB1031	REF		
R20	Res, comp, 27k \pm 5%, 1/2w	186023	01121	EB2735	1		
R21	Res, comp, 220 Ω \pm 5%, 1/2w	186031	01121	EB2215	1		
R22	Res, met flm, 10 Ω \pm 1%, 1/2w	151043	75042	Type CEC-TO	1		
R23, R25	Res, comp, 47k \pm 5%, 1/2w	108738	01121	EB4735	2		
R24	Res, comp, 620 Ω \pm 5%, 1/2w	108704	01121	EB6215	2		
R26	Res, comp, 180 Ω \pm 10%, 2w	155457	01121	HB1811	1		
R27	Res, comp, 2k \pm 5%, 1/2w	169854	01121	EB2025	2		
R28	Res, comp, 8.2k \pm 5%, 1/2w	147777	01121	EB8225	2		
	Heat sink	186759	89536	186759	1		

REF DESIG	DESCRIPTION	STOCK NO	MFR	MFR PART NO	TOT QTY	REC QTY	USE CODE
A5A3	DIFFERENTIAL AMPLIFIER P/C ASSEMBLY - Figure 5-9	219162 (335A-4057)	89536	219162	REF		
C1	Cap, plstc, 0.1 uf $\pm 10\%$, 50V	150318	56289	194P1049R5	1		
C2	Cap, mica, 510 pf $\pm 5\%$, 500V	148411	88419	CD19F511J	2		
C3	Cap, Ta, 15 uf $\pm 10\%$, 20V	153056	05397	K15C20K	REF		
C4	Cap, elect, 250 uf $+50/-10\%$, 40V	178616	73445	C437ARG250	1	1	
C5	Cap, mica, 27 pf $\pm 5\%$, 500V	177998	88419	CD15E270J	1		
CR1 thru CR 13	Diode, silicon, 1 amp, 100 piv	116111	05277	1N4817	REF		
CR14	Diode, zener, 10V	113324	07910	1N961A	REF		
CR15	Diode, silicon, 1 amp, 100 piv	116111	05277	1N4817	REF		
P1	Connector, male, 16 contact	187724	91662	02-016-013- 5-200	REF		
Q1	Tstr, silicon, NPN	177105	07263	2N3565	5		
Q2	Tstr, FET, silicon N-channel	166223	15818	U-1249	2		
Q3	Tstr, silicon, PNP	190389	04713	SM4144	REF		
Q4	Tstr, tested, silicon, NPN	198812	89536	4805-198812	2	1	
Q5, Q7	Tstr, silicon, PNP	190389	04713	SM4144	2		
Q6	Tstr, tested, silicon, NPN	198812	89536	198812	1		
Q8	Tstr, silicon, NPN	203489	07910	CDQ10656	REF		
Q9, Q10 Q11, Q12	Tstr, silicon, PNP	183558	04713	2N3250	3	1	
R1	Res, comp, 22k $\pm 5\%$, 1/2w	186064	01121	EB2235	3		
R2, R3 R5, R6	Res, comp, 100 Ω $\pm 5\%$, 1/2w	188508	01121	EB1015	6		
R4	Res, ww, 10k $\pm 0.2\%$, 1/4w	112177	89536	112177	1		
R7, R30	Res, comp, 1k $\pm 5\%$, 1/2w	108597	01121	EB1025	10		
R8	Res, comp, 3.3k $\pm 5\%$, 1/2w	165761	01121	EB3325	4		
R9	Res, comp, 3k $\pm 5\%$, 1/2w	109090	01121	EB3025	2		

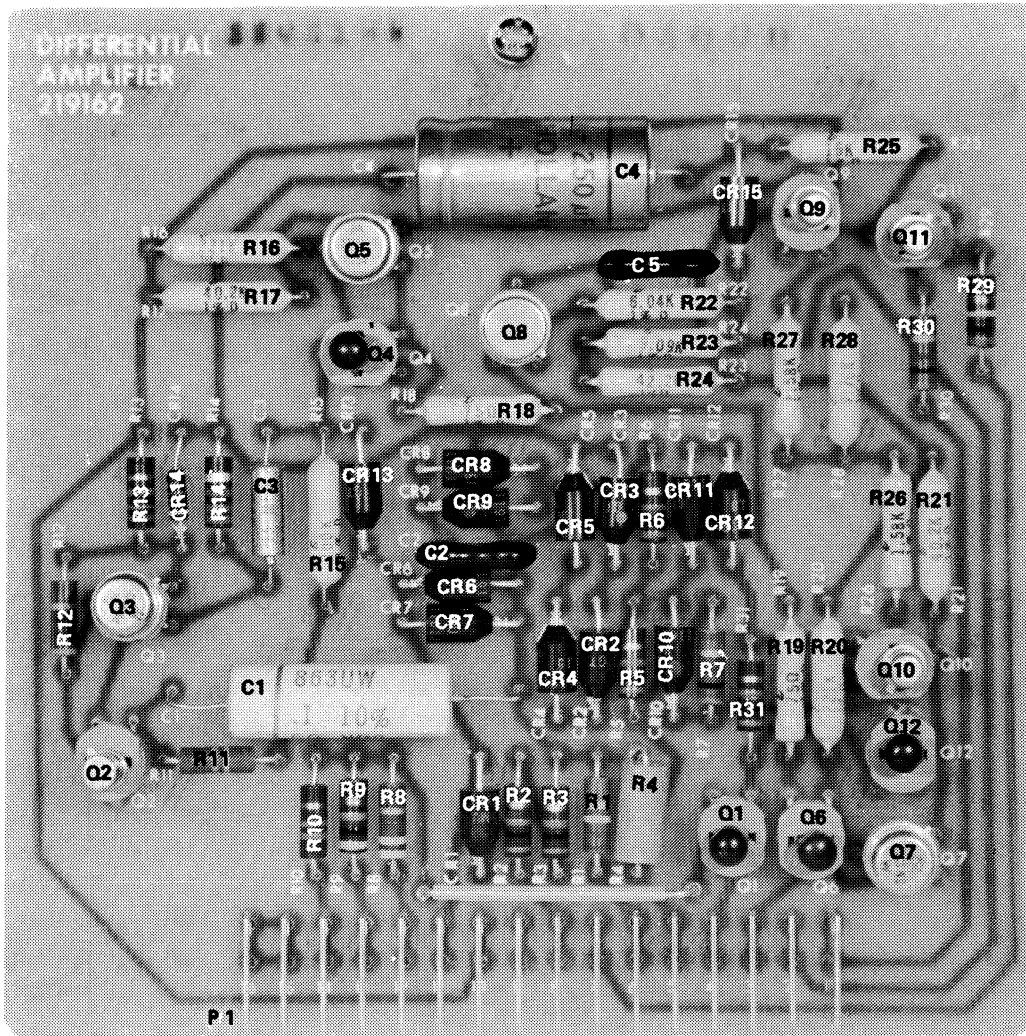

Figure 5-9. DIFFERENTIAL AMPLIFIER PRINTED CIRCUIT ASSEMBLY

REF DESIG	DESCRIPTION	STOCK NO	MFR	MFR PART NO	TOT QTY	REC QTY	USE CODE
R10	Res, comp, 510Ω ±5%, 1/2w	108951	01121	EB5115	1		
R11	Res, comp, 22M ±10%, 1/2w	108233	01121	EB2261	1		
R12	Res, comp, 6.2k ±5%, 1/2w	108621	01121	EB6225	3		
R13	Res, comp, 2.2k ±5%, 1/2w	108506	01121	EB2225	2		
R14	Res, comp, 1.2k ±10%, 1/2w	108803	01121	EB1221	1		
R15	Res, met flm, 100k ±1%, 1/2w	151316	75042	Type CEC-TO	REF		
R16, R20	Res, met flm, 221k ±1%, 1/2w	182527	75042	Type CEC-TO	REF		
R17, R21	Res, met flm, 40.2k ±1%, 1/2w	161059	75042	Type CEC-TO	2		
R18, R19	Res, met flm, 75Ω ±1%, 1/2w	150870	75042	Type CEC-TO	2		
R22	Res, met flm, 6.04k ±1%, 1/2w	162586	75042	Type CEC-TO	REF		
R23	Res, met flm, 42.2k ±1%, 1/2w	182501	75042	Type CEC-TO	1		
R24	Res, met flm, 9.09k ±1%, 1/2w	151258	75042	Type CEC-TO	1		
R25	Res, met flm, 15k ±1%, 1/2w	151498	75042	Type CEC-TO	1		
R26 R27	Res, met flm, 1.58k ±1%, 1/2w	182543	75042	Type CEC-TO	2		
R28	Res, met flm, 9.76k ±1%, 1/2w	182485	75042	Type CEC-TO	3		
R29	Res, comp, 10k ±5%, 1/2w	109165	01121	EB1035	2		
R31	Res, comp, 2k ±5%, 1/2w	169854	01121	EB2025	REF		

REF DESIG	DESCRIPTION	STOCK NO	MFR	MFR PART NO	TOT QTY	REC QTY	USE CODE
A5A4	CHOPPER AMPLIFIER ASSEMBLY Figure 5-10	251918 (333A-4004)	89536	251918			
C1	Cap, plstc, 0.1 uf $\pm 10\%$, 250V	161992	73445	C280AE/A100K	1		
C2, C3	Cap, plstc, 0.0068 uf $\pm 20\%$, 200V	106070	56289	192P68202	2		
C4	Cap, plstc, 0.047 uf $\pm 10\%$, 250V	162008	73445	C280AE/A47K	1		
C5	Cap, mica, 4 pf $\pm 5\%$, 500V	190397	14655	CD15C040K	1		
C6	Cap, mica, 640 pf $\pm 5\%$, 500V	215251	14655	CD19F6405	1		
C7, C13	Cap, elect, 5 uf $+75/-10\%$, 25V	152009	56289	30D505G025 BA4	2		
C8, C21	Cap, elect, 50 uf $+50/-10\%$, 25V	168823	73445	C426ARF50	2		
C9, C23	Cap, elect, 100 uf $+75/-10\%$, 3V	106534	56289	30D107G003 CB4	2		
C10	Cap, mica, 220 pf $\pm 5\%$, 500V	170423	14655	CD15F221J	1		
C11	Cap, cer, 100 pf $\pm 10\%$, 1 kV	105593	71590	DD-101	1		
C12	Cap, mica, 5 pf $\pm 10\%$, 500V	148577	14655	CD15C050K	1		
C14, C16	Cap, Ta, 33 uf $\pm 10\%$, 10V	182832	56289	150D336X90 10B2	2		
C15, C17	Cap, elect, 15 uf $+75/-10\%$, 6V	105700	56289	30D156G006 BA4	2		
C18	Cap, Ta, 100 uf $\pm 10\%$, 10V	170456	05397	K100C10K	1		
C19, C20	Cap, plstc, 0.015 uf $\pm 2\%$, 100V	233577	02799	1PC-153-G	2		
C22	Cap, Ta, 0.47 uf $\pm 20\%$, 35V	161349	56289	196D474X00 35	1		
CR1	Diode, zener, silicon	266601	07910	1N965B	1		
CR2 thru CR9	Diode, silicon, 150 mA	203323	03508	DHD1105	8		
IC1	IC, operational amplifier	246603	07263	U5B770939X	1		
Q1	Tstr, MOS FET, P-channel	226043	07263	FT704	1		
Q2	Tstr, FET, N-channel	271924	07910	CFE13041	1		
Q3	Tstr, silicon, PNP	195974	04713	2N3906	1		
Q4	Tstr, silicon, PNP	288761	49956	RS2048	1		
Q5 thru Q7	Tstr, silicon, NPN	218396	04713	2N3904	3		

REF DESIG	DESCRIPTION	STOCK NO	MFR	MFR PART NO	TOT QTY	REC QTY	USE CODE
R1	Res, comp, 51k \pm 5%, 1/4w	193334	01121	CB5135	1		
R2, R21, R22	Res, comp, 100k \pm 5%, 1/4w	148189	01121	CB1045	3		
R3	Res, met flm, 604k \pm 1%, 1/2w	182493	91637	TYPE MFF1/2	1		
R4	Res, comp, 10 Ω \pm 5%, 1/4w	147868	01121	CB1005	1		
R5	Res, met flm, 604k \pm 1%, 1/2w	182493	91637	TYPE MFF1/2	1		
R6	Res, comp, 3.3M \pm 5%, 1/4w	208389	01121	CB3355	1		
R7	Res, comp, 13k \pm 5%, 1/4w	221598	01121	CB1335	1		
R8, R41, R42	Res, comp, 200 Ω \pm 5%, 1/4w	193482	01121	CB2015	3		
R9, R32, R37, R39 R40	Res, comp, 22k \pm 5%, 1/4w	148130	01121	CB2235	5		
R10, R12	Res, met flm, 34k \pm 1%, 1/2w	151241	91637	TYPE MFF1/2	2		
R11	Res, comp, 10M \pm 5%, 1/4w	194944	01121	CB1065	1		
R13	Res, comp, 1.5k \pm 5%, 1/4w	148031	01121	CB1525	1		
R14	Res, met flm, 301 \pm 1%, 1/2w	167494	91637	TYPE MFF1/2	1		
R15	Res, met flm, 8.06k \pm 1%, 1/2w	159467	91637	TYPE MFF1/2	1		
R16	Res, met flm, 68.1k \pm 1%, 1/2w	161083	91637	TYPE MFF1/2	1		
R17	Res, comp, 68k \pm 5%, 1/4w	148171	01121	CB6835	1		
R18	Res, comp, 24k \pm 5%, 1/4w	193425	01121	CB2435	1		
R19, R20	Res, met flm, 10k \pm 1%, 1/2w	151274	91637	TYPE MFF1/2	2		
R23	Res, comp, 33k \pm 5%, 1/4w	148155	01121	CB3335	1		
R24	Res, comp, 10k \pm 5%, 1/4w	148106	01121	CB1035	1		
R25	Res, comp, 36k \pm 5%, 1/4w	221929	01121	CB3635	1		
R26	Res, comp, 18k \pm 5%, 1/4w	148122	01121	CB1835	1		
R27	Res, comp, 560 Ω \pm 5%, 1/4w	147991	01121	CB5615	1		
R28	Res, comp, 47k \pm 5%, 1/4w	148163	01121	CB4735	1		
R29	Res, comp, 180k \pm 5%, 1/4w	193441	01121	CB1845	1		
R30	Res, comp, 8.2k \pm 5%, 1/4w	160796	01121	CB8225	1		
R31	Res, comp, 15k \pm 5%, 1/4w	148114	01121	CB1535	1		
R33	Res, met flm, 4.22k \pm 1%, 1/2w	223396	91637	TYPE MFF1/2	1		

REF DESIG	DESCRIPTION	STOCK NO	MFR	MFR PART NO	TOT QTY	REC QTY	USE CODE
R34	Res, var cer met, 5k \pm 20%, 3/4w	159905	73138	78PR5K	1		
R35	Res, met flm, 24.3k \pm 1%, 1/2w	217430	91637	TYPE MFF1/2	1		
R36, R38	Res, met flm, 187k \pm 1%, 1/8w	289462	91637	TYPE MFF1/2	2		
R43	Res, var, comp, 10k \pm 30%, 1/4w	223131	37942	TYPE MTC	1		
	Connector, male, 16 contact	187724	91662	02-106-013-5-200	1		
	Cover, chopper	251751	89536	251751	1		

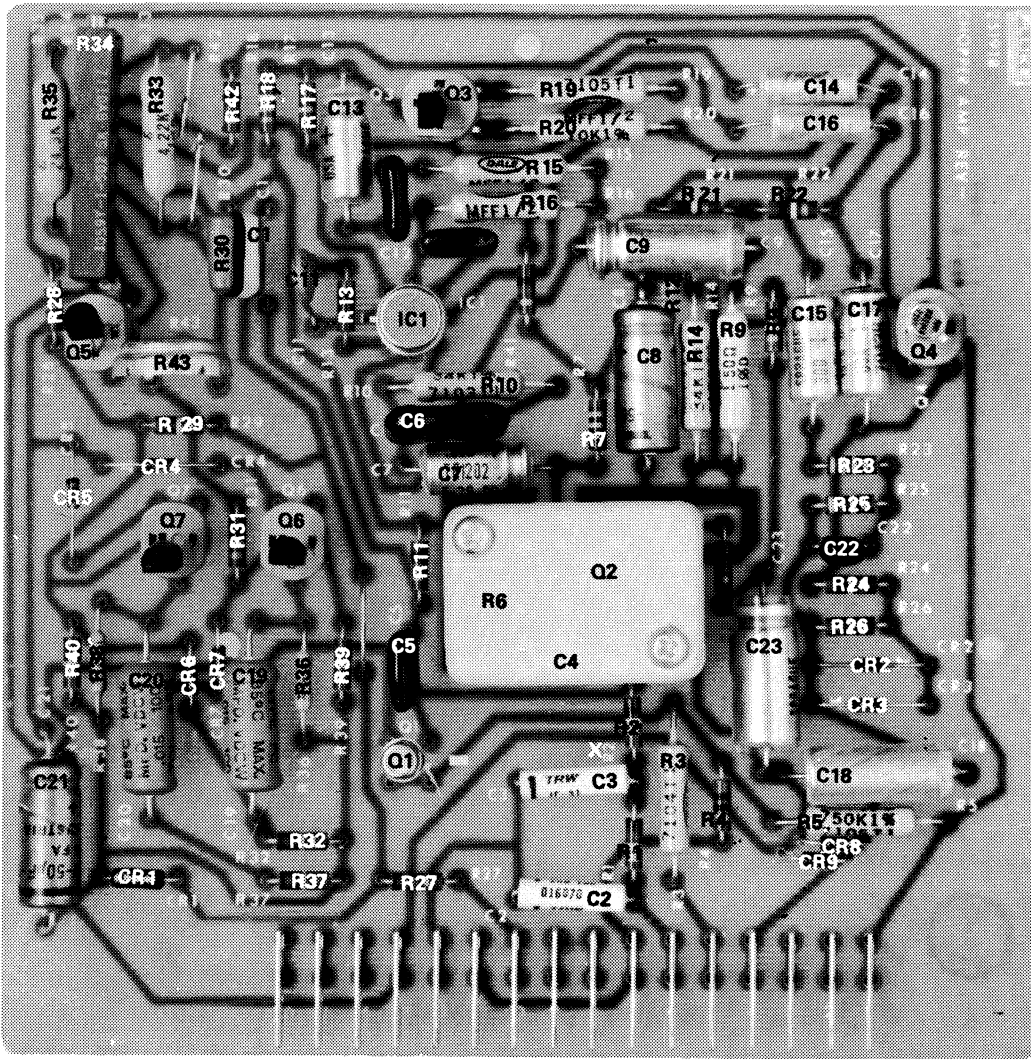

Figure 5-10. CHOPPER AMPLIFIER PRINTED CIRCUIT ASSEMBLY

REF DESIG	DESCRIPTION	STOCK NO	MFR	MFR PART NO	TOT QTY	REC QTY	USE CODE
A5A5	AUXILIARY POWER SUPPLY P/C ASSEMBLY - Figure 5-11	219188 (335A-4059)	89536	219188	REF		
C1	Cap, Ta, 68 uf $\pm 10\%$, 15V	182824	05397	K68C15K	1		
C2	Cap, elect, 250 uf $+50/-10\%$, 64V	185850	73445	C437ARH250	4	1	
C3, C8	Cap, elect, 50 uf $+75/-10\%$, 50V	105122	80183	TE1307	3	1	
C4	Cap, cer, 220 pf $\pm 10\%$, 500V	105528	72982	315-024X5UD 221K	1		
C5, C10	Cap, plstc, 2 uf $\pm 20\%$, 100V	106963	84411	Type X663FR	2		
C6	Cap, plstc, 0.1 uf $\pm 20\%$, 200V	106435	56289	192P10402	REF		
C7, C11	Cap, elect, 20 uf $+75/-10\%$, 50V	106229	80183	TE1305	REF		
C9	Cap, plstc, 0.0012 uf $\pm 10\%$, 200V	106088	56289	192P12292	1		
CR1, CR2, CR3, CR4, CR7 thru CR10	Diode, silicon, 1 amp, 100 piv	116111	05277	1N4817	REF		
CR5	Diode, zener, 3.9V	113316	07910	1N748	2	1	
CR6	Diode, zener, 6.3V	172148	03877	1N3496	1	1	
P1	Connector, male, 16 contact	187724	91662	02-016-013- 5-200	REF		
Q1	Silicon controlled rectifier, 1.6 amp, 50V	192567	03508	C-6F	2	1	
Q2	Tstr, selected, silicon, PNP	159491	89536	159491	REF		
Q3, Q5, Q6, Q8, Q9	Tstr, silicon, NPN	203489	07910	CDQ10656	REF		
Q4, Q7	Tstr, silicon, NPN	183004	95303	40250	REF		
R1	Res, comp, 10k $\pm 5\%$, 1/2w	109165	01121	EB1035	REF		
R2	Res, comp, 390 Ω $\pm 5\%$, 1/2w	109082	01121	EB3915	1		
R3	Res, comp, 5.6k $\pm 5\%$, 1/2q	187880	01121	EB5625	1		
R4	Res, comp, 15 Ω $\pm 10\%$, 2w	155549	01121	HB1505	1		
R5	Res, comp, 15k $\pm 10\%$, 1/2w	108530	01121	EB1531	REF		

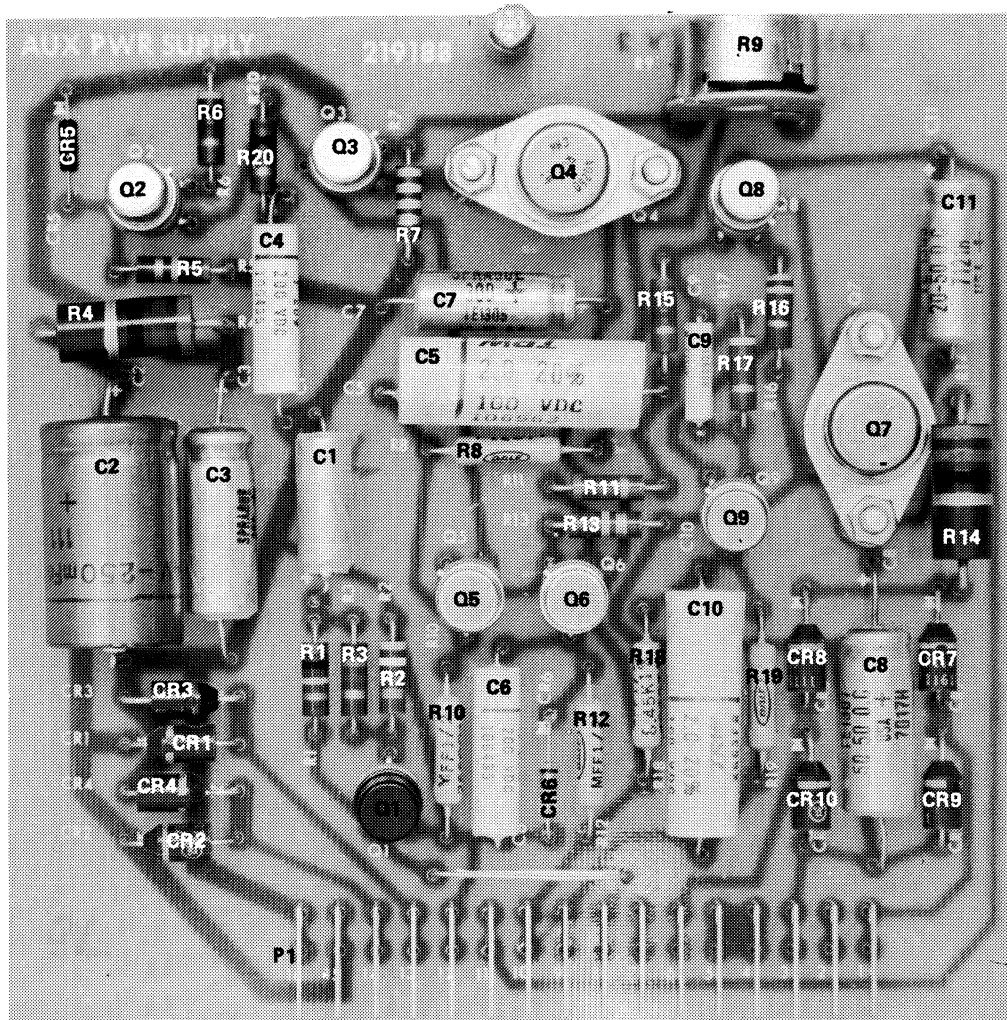

Figure 5-11. AUXILIARY POWER SUPPLY PRINTED CIRCUIT ASSEMBLY

REF DESIG	DESCRIPTION	STOCK NO	MFR	MFR PART NO	TOT QTY	REC QTY	USE CODE
R6	Res, comp, 3k \pm 5%, 1/2w	109090	01121	EB3025	REF		
R7	Res, comp, 33k \pm 10%, 1/2w	178541	01121	EB3331	REF		
R8	Res, met flm, 7.15k \pm 1%, 1/2w	186072	75042	Type CEC-TO	1		
R9	Res, var, ww, 1k \pm 20%, 1-1/4w	113266	71450	Type 110	1		
R10	Res, met flm, 2.55k \pm 1%, 1/2w	176362	75042	Type CEC-TO	1		
R11	Res, comp, 6.2k \pm 5%, 1/2w	108621	01121	EB6225	REF		
R12	Res, met flm, 2.37k \pm 1%, 1/2w	182519	75042	Type CEC-TO	1		
R13	Res, comp, 12k \pm 10%, 1/2w	108977	01121	EB1231	1		
R14	Res, comp, 82 Ω \pm 10%, 2w	110239	01121	HB8201	1		
R15	Res, comp, 8.2k \pm 5%, 1/2w	147777	01121	EB8225	REF		
R16	Res, comp, 3.3k \pm 10%, 1/2w	108373	01121	EB3321	1		
R17	Res, comp, 4.7k \pm 10%, 1/2w	108381	01121	EB4721	2		
R18	Res, met flm, 8.45k \pm 1%, 1/2w	159475	75042	Type CEC-TO	1		
R19	Res, met flm, 4.99k \pm 1%, 1/2w	148890	75042	Type CEC-TO	1		
R20	Res, comp, 2.0k \pm 5%, 1/2w	169854	01121	EB2025	REF		

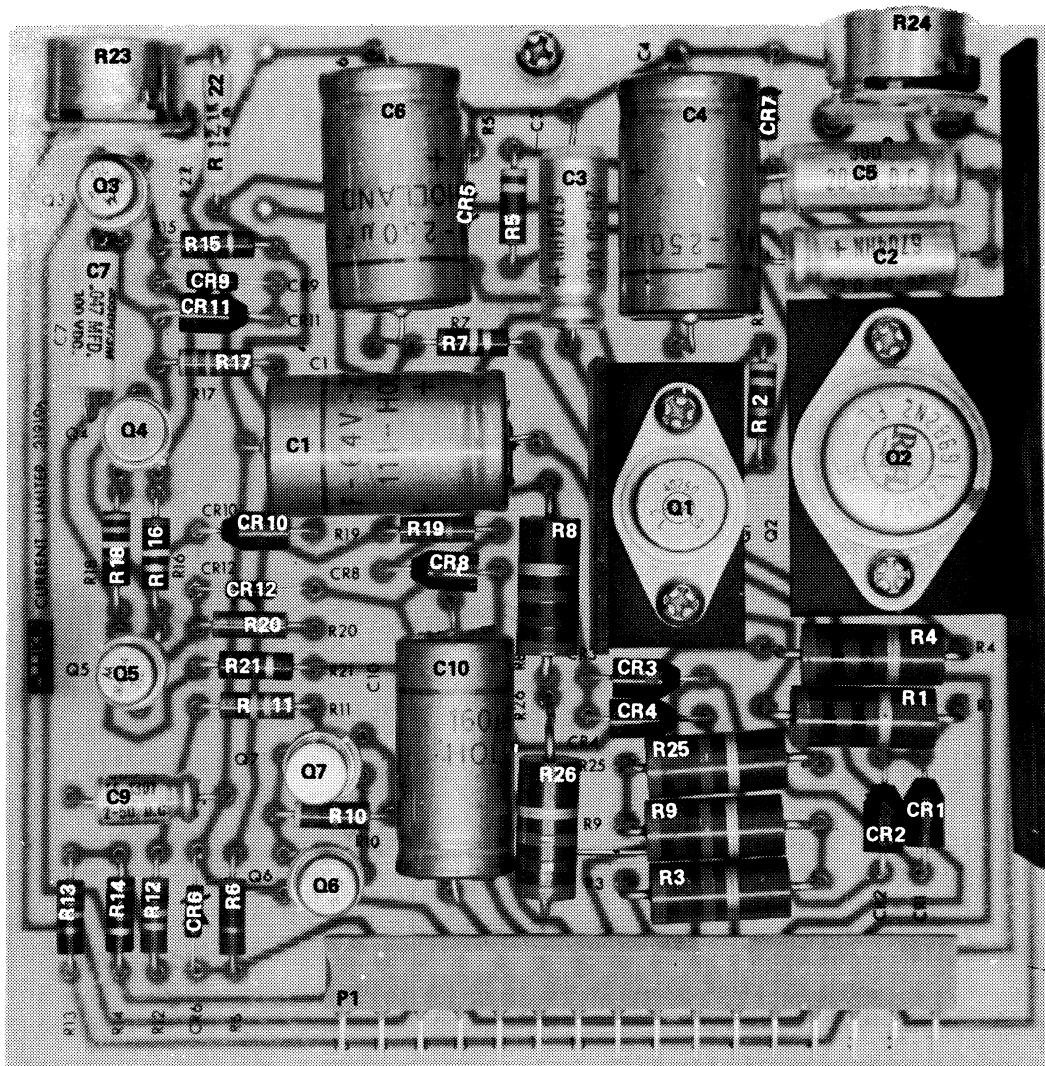

Figure 5-12. CURRENT LIMITER PRINTED CIRCUIT ASSEMBLY

REF DESIG	DESCRIPTION	STOCK NO	MFR	MFR PART NO	TOT QTY	REC QTY	USE CODE
A5A6	CURRENT LIMITER P/C ASSEMBLY - Figure 5-12	219196 (335A-4060)	89536	219196	REF		
C1	Cap, elect, 350 uF +75/-10%, 75V	292862	73445	C437ARH250	3		
C2	Cap, elect, 20 uf +75/-10%, 50V	106229	80183	TE1305	REF		
C3	Cap, elect, 20 uf +75/-10%, 50V	106229	80183	TE1305	REF		
C4	Cap, elect, 350 uF +75/-10%, 75V	292862	73445	C437ARH250	REF		
C5	Cap, elect, 20 uf +75/-10%, 50V	106229	80183	TE1305	REF		
C6	Cap, elect, 350 uF +75/-10%, 75V	292862	73445	C437ARH250	REF		
C7	Cap, plstc, 0.047 uf ±20%, 100V	106096	72928	335B473M	1		
C9	Cap, elect, 2 uf +75/-10%, 50V	105197	80183	TE1301	1	1	
C10	Cap, elect, 160 uf +50/-10%, 64V	170274	73445	C437ARH160	1	1	
CR1, CR2, CR3, CR4, CR8	Diode, silicon, 1 amp, 600 piv	112382	05277	1N4822	REF		
CR5	Diode, zener, 36V	186163	07910	1N974B	2	1	
CR6	Diode, zener, 3.9V	113316	07910	1N748	REF		
CR7	Diode, zener, 36V	237354	04713	1N3033A	1	1	
CR9	Diode, zener, 12V	159780	07910	1N759	1	1	
CR10, CR11	Diode, silicon, 1 amp, 100 piv	116111	05277	1N4817	REF		
CR12	Diode, silicon, 150 ma, 6 piv	113308	07910	CD13161	REF		
P1	Connector, male, 16 contact	187724	91662	02-016-013- 5-200	REF		
Q1	Tstr, silicon, NPN	183004	95303	40250	REF		
Q2	Tstr, germanium, PNP	152868	95303	2N2869	1	1	
Q3	Tstr, selected, silicon, PNP	159491	89536	159491	REF		
Q4, Q7	Tstr, silicon, NPN	203489	07910	CDQ10656	REF		
Q5, Q6	Tstr, selected, silicon, PNP	159491	89536	159491	REF		

REF DESIG	DESCRIPTION	STOCK NO	MFR	MFR PART NO	TOT QTY	REC QTY	USE CODE
R1, R4	Res, comp, 10 Ω \pm 10%, 2w	110163	01121	HB1001	4		
R2, R5	Res, comp, 3.3k \pm 5%, 1/2w	165761	01121	EB3325	REF		
R3, R26	Res, comp, 2.4k \pm 5%, 2w	218834	01121	HB2425	2		
R6, R19 R20	Res, comp, 7.5k \pm 5%, 1/2w	108910	01121	EB7525	3		
R7, R16	Res, comp, 100k \pm 10%, 1/2w	108126	01121	EB1041	REF		
R8, R9 R25	Res, comp, 120 Ω \pm 10%, 2w	155531	01121	HB1211	3		
R10	Res, comp, 4.7k \pm 10%, 1/2w	108381	01121	EB4721	REF		
R11, R12	Res, comp, 10k \pm 10%, 1/2w	108118	01121	EB1031	REF		
R13	Res, comp, 16k \pm 5%, 1/2w	159632	01121	EB1635	REF		
R14, R21	Res, comp, 1k \pm 10%, 1/2w	108563	01121	EB1021	REF		
R15	Res, comp, 2.2k \pm 10%, 1/2w	108605	01121	EB2221	1		
R17	Res, comp, 36k \pm 5%, 1/2w	185991	01121	EB3635	REF		
R18	Res, comp, 330k \pm 5%, 1/2w	150201	01121	EB3345	1		
R22	Res, met flm, 12.1k \pm 1%, 1/2w	182535	75042	Type CEC-TO	1		
R23	Res, var, ww, 10k \pm 10%, 1-1/4w	162115	71450	Type 110	1		
R24	Res, var, ww, 150 Ω \pm 10%, 1-1/4w	113092	71450	Type 110	1		
	Heat sink	186759	89536	186759	REF		
	Heat sink	186742	89536	186742	1		

REF DESIG	DESCRIPTION	STOCK NO	MFR	MFR PART NO	TOT QTY	REC QTY	USE CODE
A6	TIME DELAY P/C ASSEMBLY Figure 5-13	192260 (332A-420)	89536	192269	REF		
C2001	Cap, elect, 400 uf +50/-10%, 40V	185868	73445	C437ARG400	1		
CR2001 CR2002 CR2003	Diode, silicon, 1 amp, 100 piv	116111	05277	1N4817	REF		
K2001	Relay, armature, 12 vdc, dpdt	176347	80089	62-760	1		
Q2001	Silicon controlled rectifier, 1.6 amp, 50V	192567	03508	C-6F	REF		
R2001	Res, comp, 2.2k ±10%, 2w	109967	01121	HB2221	2		
R2002	Res, comp, 5.6k ±10%, 1/2w	108324	01121	EB5621	1		
R2003	Res, comp, 390Ω ±10%, 1/2w	108365	01121	EB3911	1		
R2004	Res, comp, 10k ±10%, 1/2w	108118	01121	EB1031	REF		

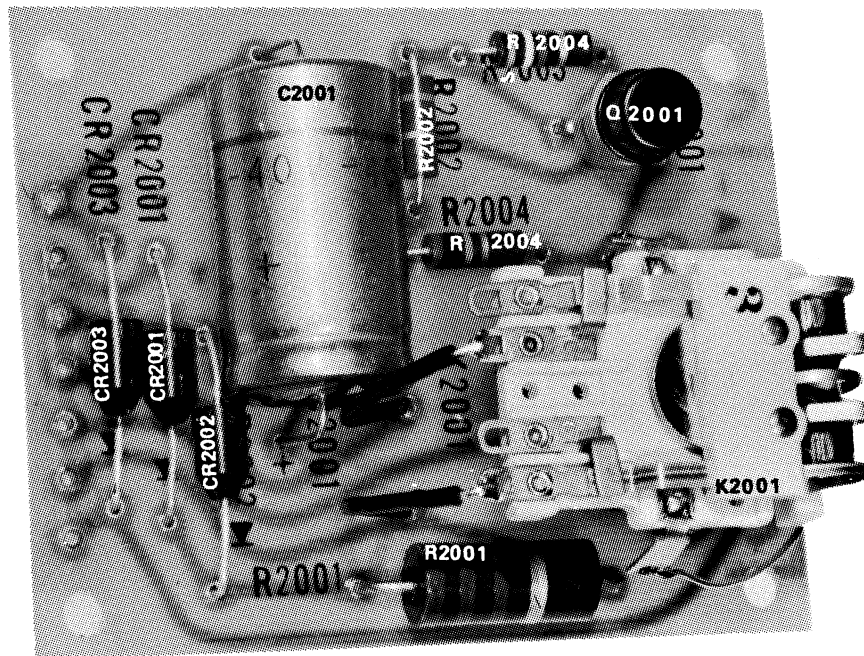

Figure 5-13. TIME DELAY PRINTED CIRCUIT ASSEMBLY

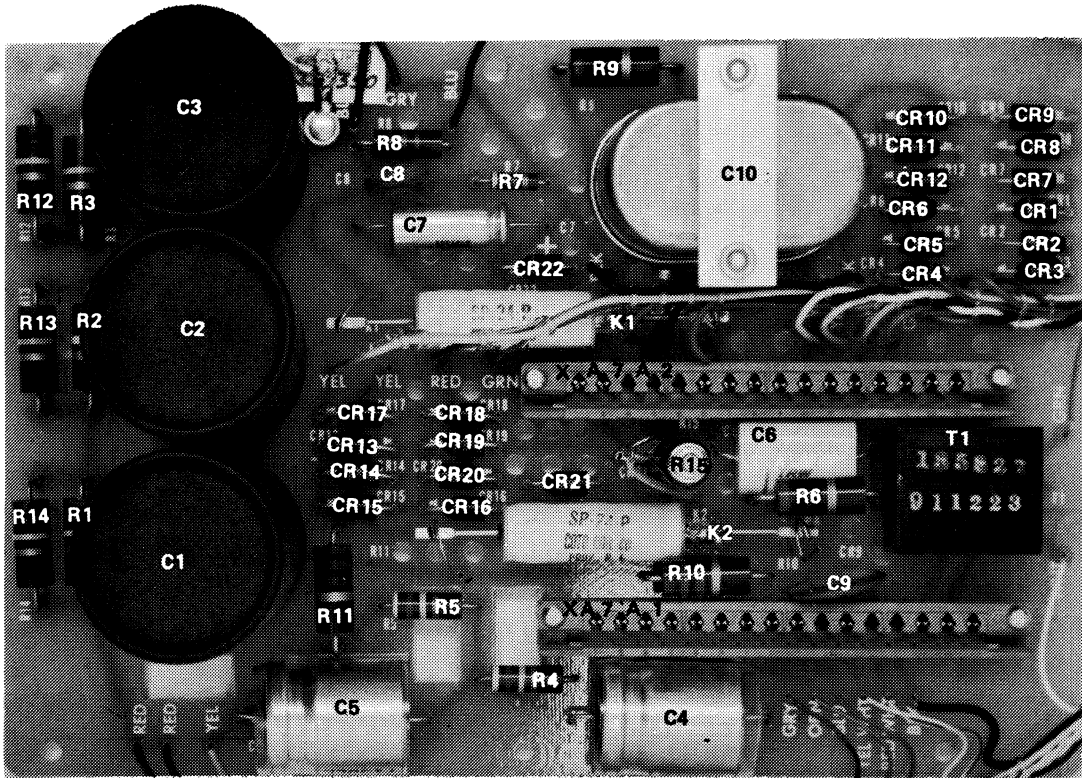

Figure 5-14. HIGH VOLTAGE MOTHER BOARD PRINTED CIRCUIT ASSEMBLY

REF DESIG	DESCRIPTION	STOCK NO	MFR	MFR PART NO	TOT QTY	REC QTY	USE CODE
A7	HIGH VOLTAGE MOTHER BOARD P/C ASSEMBLY - Figure 5-14	239350 (332B-4056)	89536	239250	REF		
A7A1	Series Pass Element P/C Assembly (See Figure 5-15)	314823 (332B-4064)	89536	314823	REF		
A7A2	Preregulator P/C Assembly (See Figure 5-16)	314815 (332B-4082)	89536	314815	REF		
C1, C2, C3	Cap, elect, 125 uf +50/-10%, 450V	106336	56289	Type 66D	3	1	
C4, C5	Cap, elect, 8 uf +50/-10%, 450V	194068	56289	39D805F- 450HE4	2		
C6, C10	Cap, plstc, 1 uf \pm 20%, 200V	106450	84411	Type X663F	2		
C7	Cap, elect, 50 uf +75/-10%, 50V	105122	80183	TE1307	1		
C8	Cap, cer, 0.001 uf \pm 20%, 3 kv	105635	80183	29C300	1		
C9	Cap, cer, 0.01 uf, gm, 1600V	106930	71590	DD16-103	REF		
CR1 thru CR19	Diode, silicon, 1 amp, 600 piv	112383	05277	1N4822	REF		
CR21, CR22	Diode, silicon, 1 amp, 100 piv	116111	05277	1N4817	REF		
K1	Relay, reed, 5,000V	184440	12617	DRVT-1	2		
	Coil, reed relay, 24V	186155	71707	SP-24-P	REF		
K2	Relay, reed, 5,000V	184440	12617	DRVT-1	REF		
	Coil, reed relay, 24V	186155	71707	SP-24-P	REF		
R1, R2 R12, thru R14	Res, comp, 220k \pm 10%, 2w	110197	01121	HB2241	6		
R4, R5	Res, comp, 470k \pm 5%, 1w	809819	01121	GB4745	2		
R6, R9	Res, comp, 10 Ω \pm 10%, 2w	110163	01121	HB1001	REF		
R7	Res, comp, 470 Ω \pm 10%, 1/2w	108415	01121	EB4711	REF		
R8	Res, comp, 5.1 Ω \pm 5%, 1w	219071	01121	GB51G5	1		
R10	Res, comp, 270 Ω \pm 10%, 2w	110189	01121	HB2711	1		
R11	Res, comp, 2.2k \pm 10%, 2w	109967	01121	HB2221	REF		
R15	Res, ww, 2k \pm 5%, 10w	155416	06136	Type 10F	1		
T1	Transformer, pulse	185827	89536	185827	1		
J1, J2	Connector, female, 16 contact	285015	91662	00-5009-016 153-001	REF		

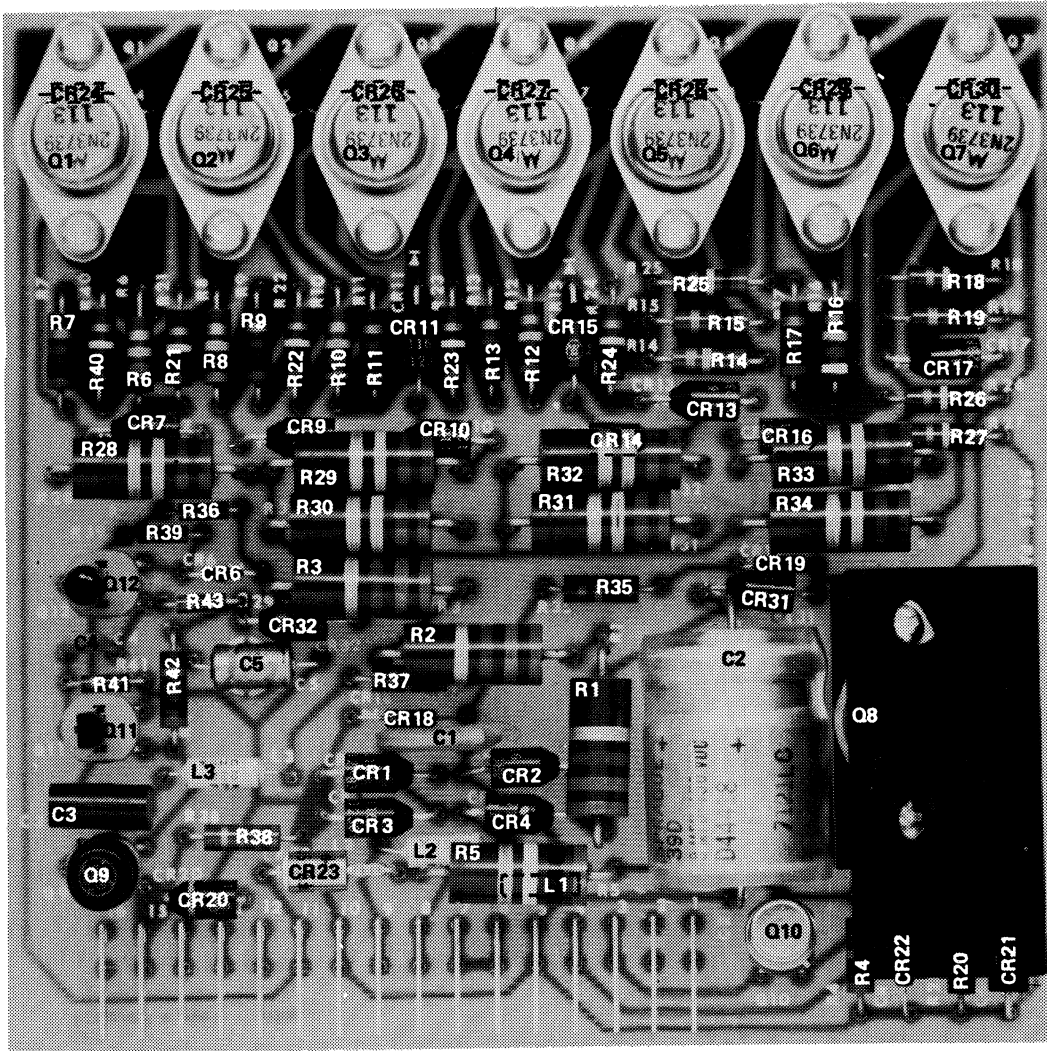

Figure 5-15. SERIES PASS ELEMENT PRINTED CIRCUIT ASSEMBLY

REF DESIG	DESCRIPTION	STOCK NO	MFR	MFR PART NO	TOT QTY	REC QTY	USE CODE
A7A1	SERIES PASS ELEMENT P/C ASSEMBLY - Figure 5-15	314823 (332B-4061)	89536	14823	REF		
C1	Cap, cer, 0.05 uf +80/-10%, 500V	105676	56289	33C58B	4		
C2	Cap, elect, 8 uf +50/-10%, 450V	194068	56289	39D805F450- HE4	REF		
C3	Cap, mylar, .0022 uf ±10%, 50V	313239	06001	75F1R5A224	1		
C4	Cap, cer, 0.005 uf ±20%, 100V	175232	56289	C023B101E- 802M	1		
C5	Cap, elect, 20 uf +50/-10%, 16V	241356	73445	C426ARE20	1		
CR1 thru CR5, CR7 thru CR17, CR31	Diode, silicon, 1 amp, 600 piv	112383	05277	1N4822	17		
CR6	Diode, zener, ±5%, 16V	313221	12969	UZ8716	1	1	
CR18	Diode, zener, 20V	113340	07910	1N968A	1	1	
CR19	Diode, zener, 36V	186163	07910	1N974B	REF		
CR20, CR21, CR32	Diode, silicon, 1 amp, 100 piv	116111	05277	1N4817	REF		
CR22	Diode, zener, 6.2V	180497	07910	1N753	1	1	
CR23 thru CR30	Diode, zener, 200V	217422	04713	1N3051A	8	1	
P1	Connector, male, 16 contact	187724	91662	02-016-013 5-200	REF		
Q1 thru Q8	Tstr, silicon, NPN	190710	04713	2N3739	8	8	
Q9	Tstr, silicon, unijunction	117176	03508	2N1671A	1	1	
Q10	Tstr, silicon, NPN	203489	07910	CDQ10656	REF		
R1 thru R3	Res, comp, 1.8k ±10%, 2w	185983	01121	HB1821	3		
R4, R8	Res, comp, 62k ±5%, 1/2w	108522	01121	EB6235	2		

REF DESIG	DESCRIPTION	STOCK NO	MFR	MFR PART NO	TOT QTY	REC QTY	USE CODE
R5	Res, comp, 100k \pm 10%, 2w	158659	01121	HB1041	1		
R6	Res, comp, 56k \pm 5%, 1/2w	219048	01121	EB5635	1		
R7, R9 R11	Res, comp, 1k \pm 5%, 1/2w	108597	01121	EB1025	REF		
R10	Res, comp, 68k \pm 5%, 1/2w	159624	01121	EB6835	1		
R12, R35	Res, comp, 75k \pm 5%, 1/2w	108928	01121	EB7535	REF		
R13, R15, R17, R19, R42	Res, comp, 1k \pm 5%, 1/2w	108597	01121	EB1025	REF		
R14	Res, comp, 82k \pm 5%, 1/2w	195966	01121	EB8235	1		
R16	Res, comp, 91k \pm 5%, 1/2w	219030	01121	EB9135	1		
R18, R21 thru R27, R40	Res, comp, 100k \pm 5%, 1/2	168054	01121	EB1045	9		
R20	Res, comp, 1.1 Ω \pm 5%, 1/2w	163717	01121	EB11G5	1		
R28, R29 thru R34	Res, comp, 22k \pm 10%, 2w	109975	01121	HB2231	7		
R36, R43	Res, comp, 5.1k \pm 5%, 1/4w	193342	01121	CB5125	REF		
R37	Res, comp, 36k \pm 5%, 1/2w	185991	01121	EB3635	REF		
R38	Res, comp, 180 Ω \pm 5%, 1/2w	108944	01121	EB1815	1		
R39	Res, comp, 1.1k \pm 5%, 1/4w	267336	01121	CB1125	1		
R41	Res, comp, 5.1k \pm 5%, 1/4w	193342	01121	CB5125	2		
	Heat sink	192245	89536	192245	1		
L1, L2	Inductance, 2.2 MH	147801	72259	WEE-2,200	2		
L3	Inductance, 220 uh	147835	72259	WEE-220	1		
Q11	Tstr, silicon NPN	218396	04713	2N3904			
Q12	Tstr, silicon NPN	177105	07263	2N3565			

REF DESIG	DESCRIPTION	STOCK NO	MFR	MFR PART NO	TOT QTY	REC QTY	USE CODE
A7A2	PREREGULATOR P/C ASSEMBLY Figure 5-16	314815 (332B-4082)	89536	314815	REF		
C1, C2 C6, C8	Cap, cer, 0.05 uf +80/-10%, 500V	105676	56289	33C58B	REF		
C3, C4	Cap, elect, 250 uf +50/-10%, 16V	187765	73445	C437ARE250			
C5	Cap, mylar, 1.0 uf ±20%, 200V	106450	72928	364	1		
C7	Cap, mylar, .001 uf ±10%, 200V	159582	56289	192P10292	1		
CR1 thru CR5, CR15 thru CR17	Diode, silicon, 1 amp, 100 piv	116111	05277	1N4817	REF		
CR6 thru CR9	Diode, silicon, 1 amp, 600 piv	112383	05277	1N4822	REF		
CR10 thru CR13	Diode, silicon, 3 amp, 200 piv	187716	04713	MR1032B	4		
CR14	Diode, zener, 200V	187617	04713	1N3350RA	1	1	
K1	Relay, armature, 115 vac, dpdt	106864	16332	100-5ADPDT	1		
K2	Relay, reed, 500V	136630	12617	Type DRG-1	1		
	Coil, reed relay, 24V	186155	71707	SP-24-P	REF		
P1	Connector, male, 16 contact	187724	91662	02-016-013- 5-200	REF		
Q1	Tstr, silicon, NPN	193953	05277	320C034H31	1	1	
Q2	Tstr, silicon, NPN	261347	16758	Type DTS410	1		
Q3	Tstr, tested, silicon, NPN	203489	07910	CDQ10656	REF		
Q4, Q6	Tstr, tested, silicon, PNP	159491	89536	4805-159491	REF		
Q5, Q7	Tstr, silicon, NPN	203489	07910	CDQ10656	REF		
Q8, Q9	Tstr, silicon, PNP	159491	89536	159491	REF		
R1	Res, comp, 68Ω ±10%, 2w	110205	01121	HB6801	1		
R2	Res, ww, 0.192Ω ±1%, 3w	238741	89536	238741	1	1	
R4	Res, ww, 1k ±5%, 5w	113282	63743	Type 5F1000	1		

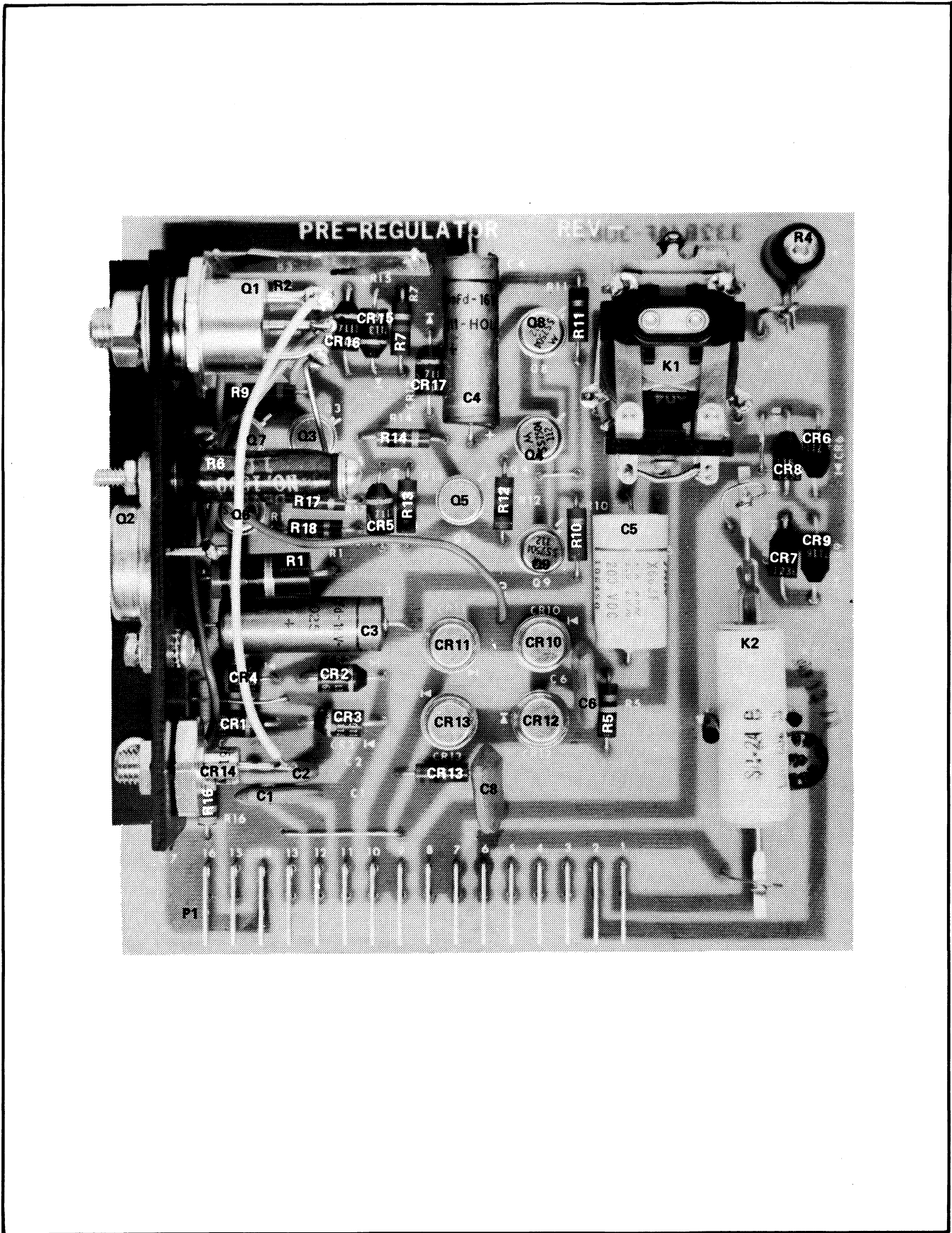

Figure 5-16. PREREGULATOR PRINTED CIRCUIT ASSEMBLY

REF DESIG	DESCRIPTION	STOCK NO	MFR	MFR PART NO	TOT QTY	REC QTY	USE CODE
R5	Res, comp, 22k \pm 5%, 1/2w	186064	01121	EB2235	REF		
R6	Res, ww, 1 Ω \pm 10%, 5w	112425	44655	1K48F	1		
R7	Res, comp, 220 Ω \pm 10%, 1/2w	108191	01121	EB2211	1		
R8	Res, comp, 430 Ω \pm 5%, 1/2w	109058	01121	EB4315	1		
R9	Res, comp, 100 Ω \pm 5%, 1/2w	188508	01121	EB1015	REF		
R10	Res, comp, 2.2k \pm 5%, 1/2w	108506	01121	EB2035	REF		
R11	Res, comp, 100 Ω \pm 5%, 1/2w	188508	01121	EB1015	REF		
R12	Res, comp, 1k \pm 5%, 1/2w	108597	01121	EB1025	REF		
R13, R14, R17	Res, comp, 1k \pm 5%, 1/2w	108597	01121	EB1025	3		
R15	Res, comp, 4.7k \pm 5%, 1/2w	108886	01121	EB4725	1		
R16	Res, comp, 3.3k \pm 5%, 1/2w	165761	01121	EB3325	REF		
R18	Res, comp, 560 Ω \pm 5%, 1/2w	109124	01121	EB5615	1		
R19	Res, comp, 68 Ω \pm 5%, 1/2w	178384	01121	EB6805	1		
	Heat sink	314807	89536	314807	1		

Section 6

Option & Accessory Information

There are no options or accessories available for use with the Model 332D DC Voltage Standard, other than the rack mounting kits described earlier in section 2 of this manual.

Section 7
General Information

7-1. This section of the manual contains generalized user information as well as supplemental information to the List of Replaceable Parts contained in Section 5.

List of Abbreviations and Symbols

A or amp	ampere	hf	high frequency	(+) or pos	positive
ac	alternating current	Hz	hertz	pot	potentiometer
af	audio frequency	IC	integrated circuit	p-p	peak-to-peak
a/d	analog-to-digital	if	intermediate frequency	ppm	parts per million
assy	assembly	in	inch(es)	PROM	programmable read-only memory
AWG	american wire gauge	intl	internal	psi	pound-force per square inch
B	bel	I/O	input/output	RAM	random-access memory
bcd	binary coded decimal	k	kilo (10 ³)	rf	radio frequency
°C	Celsius	kHz	kilohertz	rms	root mean square
cap	capacitor	kΩ	kilohm(s)	ROM	read-only memory
ccw	counterclockwise	kV	kilovolt(s)	s or sec	second (time)
cer	ceramic	lf	low frequency	scope	oscilloscope
cermet	ceramic to metal(seal)	LED	light-emitting diode	SH	shield
ckt	circuit	LSB	least significant bit	Si	silicon
cm	centimeter	LSD	least significant digit	serno	serial number
cmrr	common mode rejection ratio	M	mega (10 ⁶)	sr	shift register
comp	composition	m	milli (10 ⁻³)	Ta	tantalum
cont	continue	mA	milliampere(s)	tb	terminal board
crt	cathode-ray tube	max	maximum	tc	temperature coefficient or temperature compensating
cw	clockwise	mf	metal film	tcxo	temperature compensated crystal oscillator
d/a	digital-to-analog	MHz	megahertz	tp	test point
dac	digital-to-analog converter	min	minimum	u or μ	micro (10 ⁻⁶)
dB	decibel	mm	millimeter	uhf	ultra high frequency
dc	direct current	ms	millisecond	us or μs	microsecond(s) (10 ⁻⁶)
dmm	digital multimeter	MSB	most significant bit	uut	unit under test
dvm	digital voltmeter	MSD	most significant digit	V	volt
elect	electrolytic	MTBF	mean time between failures	v	voltage
ext	external	MTTR	mean time to repair	var	variable
F	farad	mV	millivolt(s)	vco	voltage controlled oscillator
°F	Fahrenheit	mv	multivibrator	vhf	very high frequency
FET	Field-effect transistor	MΩ	megohm(s)	vlf	very low frequency
ff	flip-flop	n	nano (10 ⁻⁹)	W	watt(s)
freq	frequency	na	not applicable	ww	wire wound
FSN	federal stock number	NC	normally closed	xfmr	transformer
g	gram	(-) or neg	negative	xstr	transistor
G	giga (10 ⁹)	NO	normally open	xtal	crystal
gd	guard	ns	nanosecond	xtlo	crystal oscillator
Ge	germanium	opnl ampl	operational amplifier	Ω	ohm(s)
GHz	gigahertz	p	pico (10 ⁻¹²)	μ	micro (10 ⁻⁶)
gmV	guaranteed minimum value	para	paragraph		
gnd	ground	pcb	printed circuit board		
H	henry	pF	picofarad		
hd	heavy duty	pn	part number		

Federal Supply Codes for Manufacturers

00213 Nytronics Comp. Group Inc. Subsidiary of Nytronics Inc. Formerly Sage Electronics Rochester, New York	02660 Bunker Ramo Corp., Conn Div. Formerly Amphenol-Borg Electric Corp. Broadview, Illinois	04946 Standard Wire & Cable Los Angeles, California	06751 Components, Inc. Semcor Div. Phoenix, Arizona
00327 Welwyn International, Inc. Westlake, Ohio	02799 Areo Capacitors, Inc. Chatsworth, California	05082 Replaced by 94988	06860 Gould Automotive Div. City of Industry, California
00656 Aerovox Corp. New Bedford, Massachusetts	03508 General Electric Co. Semiconductor Products Syracuse, New York	05236 Jonathan Mfg. Co. Fullerton, California	06961 Vernitron Corp., Piezo Electric Div. Formerly Clevite Corp., Piezo Electric Div. Bedford, Ohio
00686 Film Capacitors, Inc. Passaic, New Jersey	03614 Replaced by 71400	05245 Components Corp. now Corcom, Inc. Chicago, Illinois	06980 Eimac Div. Varian Associates San Carlos, California
00779 AMP Inc. Harrisburg, Pennsylvania	03651 Replaced by 44655	05277 Westinghouse Electric Corp. Semiconductor Div. Youngwood, Pennsylvania	07047 The Ross Milton Co. South Hampton, Pennsylvania
01121 Allen-Bradley Co. Milwaukee, Wisconsin	03797 Eldema Div. Genisco Technology Corp. Compton, California	05278 Replaced by 43543	07115 Replaced by 14674
01281 TRW Electronic Comp. Semiconductor Operations Lawndale, California	03877 Transistron Electronic Corp. Wakefield, Massachusetts	05279 Southwest Machine & Plastic Co. Glendora, California	07138 Westinghouse Electric Corp., Electronic Tube Div. Horsehead, New York
01295 Texas Instruments, Inc. Semiconductor Group Dallas, Texas	03888 KDI Pyrofilm Corp. Whippany, New Jersey	05397 Union Carbide Corp. Materials Systems Div. New York, New York	07233 TRW Electronic Components Cinch Graphic City of Industry, California
01537 Motorola Communications & Electronics Inc. Franklin Park, Illinois	03911 Clairex Electronics Div. Clairex Corp. Mt. Vernon, New York	05571 Use 56289 Sprague Electric Co. Pacific Div. Los Angeles, California	07256 Silicon Transistor Corp. Div. of BBF Group Inc. Chelmsford, Massachusetts
01686 RCL Electronics Inc. Manchester, New Hampshire	03980 Muirhead Inc. Mountainside, New Jersey	05574 Viking Industries Chatsworth, California	07261 Aumet Corp. Culver City, California
01730 Replaced by 73586	04009 Arrow Hart Inc. Hartford, Connecticut	05704 Replaced by 16258	07263 Fairchild Semiconductor Div. of Fairchild Camera & Instrument Corp. Mountain View, California
01884 Use 56289 Sprague Electric Co. Dearborn Electronic Div. Lockwood, Florida	04062 Replaced by 72136	05820 Wakefield Engineering Inc. Wakefield, Massachusetts	07344 Bircher Co., Inc. Rochester, New York
02114 Ferroxcube Corp. Saugerties, New York	04202 Replaced by 81312	06001 General Electric Co. Electronic Capacitor & Battery Products Dept. Columbia, South Carolina	07597 Burndy Corp. Tape/Cable Div. Rochester, New York
02131 General Instrument Corp. Harris ASW Div. Westwood, Maine	04217 Essex International Inc. Wire & Cable Div. Anaheim, California	06136 Replaced by 63743	07792 Lerma Engineering Corp. Northampton, Massachusetts
02395 Rason Mfg. Co. Brooklyn, New York	04221 Aemco, Div. of Midtex Inc. Mankato, Minnesota	06383 Panduit Corp. Tinley Park, Illinois	07910 Teledyne Semiconductor Formerly Continental Device Hawthorne, California
02533 Snelgrove, C.R. Co., Ltd. Don Mills, Ontario, Canada M3B 1M2	04222 AVX Ceramics Div. AVX Corp. Myrtle Beach, Florida	06473 Bunker Ramo Corp. Amphenol SAMS Div. Chatsworth, California	07933 Use 49956 Raytheon Co. Semiconductor Div. HQ Mountain View, California
02606 Fenwal Labs Div. of Travenal Labs. Morton Grove, Illinois	04423 Telonic Industries Laguna Beach, California	06555 Beede Electrical Instrument Co. Penacook, New Hampshire	08225 Industro Transistor Corp. Long Island City, New York
	04645 Replaced by 75376	06739 Electron Corp. Littleton, Colorado	
	04713 Motorola Inc. Semiconductor Products Phoenix, Arizona	06743 Clevite Corp. Cleveland, Ohio	

Federal Supply Codes for Manufacturers (cont)

08261 Spectra Strip Corp. Garden Grove, California	11726 Qualidyne Corp. Santa Clara, California	13606 Use 56289 Sprague Electric Co. Transistor Div. Concord, New Hampshire	16299 Corning Glass Electronic Components Div. Raleigh, North Carolina
08530 Reliance Mica Corp. Brooklyn, New York	12014 Chicago Rivet & Machine Co. Bellwood, Illinois	13839 Replaced by 23732	16332 Replaced by 28478
08806 General Electric Co. Miniature Lamp Products Dept Cleveland, Ohio	12040 National Semiconductor Corp. Danbury, Connecticut	14099 Semtech Corp. Newbury Park, California	16473 Cambridge Scientific Ind. Div. of Chemed Corporation Cambridge, Maryland
08863 Nylomatic Corp. Norrisville, Pennsylvania	12060 Diodes, Inc. Chatsworth, California	14140 Edison Electronic Div. Mc Gray-Edison Co. Manchester, New Hampshire	16742 Paramount Plastics Fabricators, Inc. Downey, California
08988 Use 53085 Skottie Electronics Inc. Archbald, Pennsylvania	12136 Philadelphia Handle Co. Camden, New Jersey	14193 Cal-R-Inc. formerly California Resistor, Corp. Santa Monica, California	16758 Delco Electronics Div. of General Motors Corp. Kokomo, Indiana
09214 G.E. Co. Semi-Conductor Products Dept. Power Semi-Conductor Products OPN Sec. Auburn, New York	12300 Potter-Brumfield Div. AMF Canada LTD. Guelph, Ontario, Canada	14298 American Components, Inc. an Insilco Co. Conshohocken, Pennsylvania	17001 Replaced by 71468
09353 C and K Components Watertown, Massachusetts	12323 Presin Co., Inc. Shelton, Connecticut	14655 Cornell-Dublier Electronics Division of Federal Pacific Electric Co. Govt. Control Dept. Newark, New Jersey	17069 Circuit Structures Lab. Burbank, California
09423 Scientific Components, Inc. Santa Barbara, California	12327 Freeway Corp. formerly Freeway Washer & Stamping Co. Cleveland, Ohio	14752 Electro Cube Inc. San Gabriel, California	17338 High Pressure Eng. Co., Inc. Oklahoma City, Oklahoma
09922 Burndy Corp. Norwalk, Connecticut	12443 The Budd Co. Polychem Products Plastic Products Div. Bridgeport, Pennsylvania	14869 Replaced by 96853	17545 Atlantic Semiconductors, Inc. Asbury Park, New Jersey
09969 Dale Electronics Inc. Yankton, S. Dakota	12615 U.S. Terminals Inc. Cincinnati, Ohio	14936 General Instrument Corp. Semi Conductor Products Group Hicksville, New York	17856 Siliconix, Inc. Santa Clara, California
10059 Barker Engineering Corp. Formerly Amerace, Amerace ESNA Corp. Kenilworth, New Jersey	12617 Hamlin Inc. Lake Mills, Wisconsin	15636 Elec-Trol Inc. Saugus, California	17870 Replaced by 14140
11236 CTS of Berne Berne, Indiana	12697 Clarostat Mfg. Co. Dover, New Hampshire	15801 Fenwal Electronics Inc. Div. of Kidde Walter and Co., Inc. Framingham, Massachusetts	18178 Vactec Inc. Maryland Heights, Missouri
11237 CTS Keene Inc. Paso Robles, California	12749 James Electronics Chicago, Illinois	15818 Teledyne Semiconductors, formerly Amelco Semiconductor Mountain View, California	18324 Signetics Corp. Sunnyvale, California
11358 CBS Electronic Div. Columbia Broadcasting System Newburyport, Minnesota	12856 Micrometals Sierra Madre, California	15849 Litton Systems Inc. Useco Div. formerly Useco Inc. Van Nuys, California	18612 Vishay Resistor Products Div. Vishay Intertechnology Inc. Malvern, Pennsylvania
11403 Best Products Co. Chicago, Illinois	12954 Dickson Electronics Corp. Scottsdale, Arizona	15898 International Business Machines Corp. Essex Junction, Vermont	18736 Voltronics Corp. Hanover, New Jersey
11503 Keystone Columbia Inc. Warren, Michigan	12969 Unitrode Corp. Watertown, Massachusetts	15909 Replaced by 14140	18927 GTE Sylvania Inc. Precision Material Group Parts Division Titusville, Pennsylvania
11532 Teledyne Relays Hawthorne, California	13103 Thermalloy Co., Inc. Dallas, Texas	16258 Space-Lok Inc. Burbank, California	19451 Perine Machinery & Supply Co. Seattle, Washington
11711 General Instrument Corp. Rectifier Division Hicksville, New York	13327 Solitron Devices Inc. Tappan, New York	16758 Space-Lok Inc. Burbank, California	19701 Electro-Midland Corp. Mepco-Electra Inc. Mineral Wells, Texas
	13511 Amphenol Cadre Div. Bunker-Ramo Corp. Los Gatos, California		20584 Enochs Mfg. Inc. Indianapolis, Indiana

Federal Supply Codes for Manufacturers (cont)

20891 Self-Organizing Systems, Inc. Dallas, Texas	28480 Hewlett Packard Co. Corporate HQ Palo Alto, California	43543 Nytronics Inc. Transformer Co. Div. Geneva, New York	70903 Belden Corp. Geneva, Illinois
21604 Buchey Stamping Co. Columbus, Ohio	28520 Heyman Mfg. Co. Kenilworth, New Jersey	44655 Ohmite Mfg. Co. Skokie, Illinois	71002 Birnbach Radio Co., Inc. Freeport, New York
21845 Solitron Devices Inc. Transistor Division Riveria Beach, Florida	29083 Monsanto, Co., Inc. Santa Clara, California	49671 RCA Corp. New York, New York	71400 Bussmann Mfg. Div. of McGraw-Edison Co. Saint Louis, Missouri
22767 ITT Semiconductors Palo Alto, California	29604 Stackpole Components Co. Raleigh, North Carolina	49956 Raytheon Company Lexington, Massachusetts	71450 CTS Corp. Elkhart, Indiana
23050 Product Comp. Corp. Mount Vernon, New York	30148 AB Enterprise Inc. Ahoskie, North Carolina	50088 Mostek Corp. Carrollton, Texas	71468 ITT Cannon Electric Inc. Santa Ana, California
23732 Tracor Inc. Rockville, Maryland	30323 Illinois Tool Works, Inc. Chicago, Illinois	50579 Litronix Inc. Cupertino, California	71482 Clare, C.P. & Co. Chicago, Illinois
23880 Stanford Applied Engrng. Santa Clara, California	31091 Optimax Inc. Colmar, Pennsylvania	51605 Scientific Components Inc. Linden, New Jersey	71590 Centrelab Electronics Div. of Globe Union Inc. Milwaukee, Wisconsin
23936 Pamotor Div., Wm. J. Purdy Co. Burlingame, California	32539 Mura Corp. Great Neck, New York	53021 Sangamo Electric Co. Springfield, Illinois	71707 Coto Coil Co., Inc. Providence, Rhode Island
24248 Replaced by 94222	32767 Griffith Plastic Corp. Burlingame, California	54294 Cutler-Hammer Inc. formerly Shallcross, A Cutter-Hammer Co. Selma, North Carolina	71744 Chicago Miniature Lamp Works Chicago, Illinois
24355 Analog Devices Inc. Norwood, Massachusetts	32879 Advanced Mechanical Components Northridge, California	55026 Simpson Electric Co. Div. of Am. Gage and Mach. Co. Elgin, Illinois	71785 TRW Electronics Components Cinch Connector Operations Div. Elk Grove Village Chicago, Illinois
24655 General Radio Concord, Massachusetts	32897 Erie Technological Products, Inc. Frequency Control Div. Carlisle, Pennsylvania	56289 Sprague Electric Co. North Adams, Massachusetts	72005 Wilber B. Driver Co. Newark, New Jersey
24759 Lenox-Fugle Electronics Inc. South Plainfield, New Jersey	32997 Bourns Inc. Trimpot Products Division Riverside, California	58474 Superior Electric Co. Bristol, Connecticut	72092 Replaced by 06980
25088 Siemen Corp. Isilen, New Jersey	33173 General Electric Co. Products Dept. Owensboro, Kentucky	60399 Torin Corp. formerly Torrington Mfg. Co. Torrington, Connecticut	72136 Electro Motive Mfg. Co. Williamantic, Connecticut
25403 Amperex Electronic Corp. Semiconductor & Micro-Circuits Div. Slatersville, Rhode Island	34333 Silicon General Westminister, California	63743 Ward Leonard Electric Co., Inc. Mount Vernon, New York	72259 Nytronics Inc. Pelham Manor, New Jersey
27014 National Semiconductor Corp. Santa Clara, California	34335 Advanced Micro Devices Sunnyvale, California	64834 West Mfg. Co. San Francisco, California	72619 Dialight Div. Amperex Electronic Corp. Brooklyn, New York
27264 Molex Products Downers Grove, Illinois	34802 Electromotive Inc. Kenilworth, New Jersey	65092 Weston Instruments Inc. Newark, New Jersey	72653 G.C. Electronics Div. of Hydrometals, Inc. Brooklyn, New York
28213 Minnesota Mining & Mfg. Co. Consumer Products Div. St. Paul, Minnesota	37942 P.R. Mallory & Co., Inc. Indianapolis, Indiana	66150 Winslow Tele-Tronics Inc. Eaton Town, New Jersey	72665 Replaced by 90303
28425 Serv--Link formerly Bohannon Industries Fort Worth, Texas	42498 National Radio Melrose, Massachusetts	70485 Atlantic India Rubber Works Chicago, Illinois	72794 Dzus Fastener Co., Inc. West Islip, New York
28478 Deltrol Controls Div. Deltrol Corporation Milwaukee, Wisconsin		70563 Amperite Company Union City, New Jersey	72928 Gulton Ind. Inc. Gudeman Div. Chicago, Illinois

Federal Supply Codes for Manufacturers (cont)

72982 Erie Tech. Products Inc. Erie, Pennsylvania	75382 Kulka Electric Corp. Mount Vernon, New York	80583 Hammarlund Mfg. Co., Inc. Red Bank, New Jersey	83594 Burrhoughs Corp. Electronic Components Div. Plainfield, New Jersey
73138 Bechman Instrument Inc. Helipot Division Fullerton, California	75915 Littlefuse Inc. Des Plaines, Illinois	80640 Arnold Stevens, Inc. South Boston, Massachusetts	83740 Union Carbide Corp. Battery Products Div. formerly Consumer Products Div. New York, New York
73293 Hughes Aircraft Co. Electron Dynamics Div. Torrance, California	76854 Oak Industries Inc. Switch Div. Crystal Lake, Illinois	81073 Grayhill, Inc. La Grange, Illinois	84171 Arco Electronics Great Neck, New York
73445 Amperex Electronic Corp. Hicksville, New York	77342 AMF Inc. Potter & Brumfield Div. Princeton, Indiana	81312 Winchester Electronics Div. of Litton Industries Inc. Oakville, Connecticut	84411 TRW Electronic Components TRW Capacitors Ogallala, Nebraska
73559 Carling Electric Inc. West Hartford, Connecticut	77638 General Instrument Corp. Rectifier Division Brooklyn, New York	81483 Therm-O-Disc Inc. Mansfield, Ohio	84613 Fuse Indicator Corp. Rockville, Maryland
73586 Circle F Industries Trenton, New Jersey	77969 Rubbercraft Corp. of CA. LTD. Torrance, California	81483 International Rectifier Corp. Los Angeles, California	84682 Essex International Inc. Industrial Wire Div. Peabody, Massachusetts
73734 Federal Screw Products, Inc. Chicago, Illinois	78189 Shakeproof Div. of Illinois Tool Works Inc. Elgin, Illinois	81590 Korry Mfg. Co. Seattle, Washington	86577 Precision Metal Products of Malden Inc. Stoneham, Massachusetts
73743 Fischer Special Mfg. Co. Cincinnati, Ohio	78277 Sigma Instruments, Inc. South Braintree, Massachusetts	81741 Chicago Lock Co. Chicago, Illinois	86684 Radio Corp. of America Electronic Components Div. Harrison, New Jersey
73899 JFD Electronics Co. Components Corp. Brooklyn, New York	78488 Stackpole Carbon Co. Saint Marys, Pennsylvania	82305 Palmer Electronics Corp. South Gate, California	86928 Seastrom Mfg. Co., Inc. Glendale, California
73949 Guardian Electric Mfg. Co. Chicago, Illinois	78553 Eaton Corp. Engineered Fastener Div. Tinnerman Plant Cleveland, Ohio	82389 Switchcraft Inc. Chicago, Illinois	87034 Illuminated Products Inc. Subsidiary of Oak Industries Inc. Anahiem, California
74199 Quan Nichols Co. Chicago, Illinois	79136 Waldes Kohinoor Inc. Long Island City, New York	82415 North American Phillips Controls Corp. Frederick, Maryland	88219 Gould Inc. Industrial Div. Trenton, New Jersey
74217 Radio Switch Corp. Marlboro, New Jersey	79497 Western Rubber Company Goshen, Indiana	82872 Roanwell Corp. New York, New York	88245 Litton Systems Inc. Useco Div. Van Nuys, California
74276 Signalite Div. General Instrument Corp. Neptune, New Jersey	79963 Zierick Mfg. Corp. Mt. Kisko, New York	82877 Rotron Inc. Woodstock, New York	88419 Cornell-Dubilier Electronic Div. Federal Pacific Co. Fuquay-Varian, North Carolina
74306 Piezo Crystal Co. Carlisle, Pennsylvania	80031 Electro-Midland Corp. Mepco Div. A North American Phillips Co. Norristown, New Jersey	82879 ITT Royal Electric Div. Pawtucket, Rhode Island	88486 Plastic Wire & Cable Jewitt City, Connecticut
74542 Hoyt Elect. Instr. Works Penacook, New Hampshire	80183 Use 56289 Sprague Products North Adams, Massachusetts	83003 Varo Inc. Garland, Texas	88690 Replaced by 04217
74970 Johnson E.F., Co. Waseca, Minnesota	80183 Use 56289 Sprague Products North Adams, Massachusetts	83058 The Carr Co., United Can Div. of TRW Cambridge, Massachusetts	89536 John Fluke Mfg. Co., Inc. Seattle, Washington
75042 TRW Electronics Components IRC Fixed Resistors Philadelphia, Pennsylvania	80294 Bourns Inc., Instrument Div. Riverside, California	83298 Bendix Corp. Electric Power Div. Eatontown, New Jersey	89730 G.E. Co., Newark Lamp Works Newark, New Jersey
75376 Kurz-Kasch Inc. Dayton, Ohio		83330 Herman H. Smith, Inc. Brooklyn, New York	
75378 CTS Knights Inc. Sandwich, Illinois		83730 Rubbercraft Corp. of America, Inc. West Haven, Connecticut	

Federal Supply Codes for Manufacturers (cont)

90201 Mallory Capacitor Co. Div. of P.R. Mallory Co., Inc. Indianapolis, Indiana	91836 King's Electronics Co., Inc. Tuckahoe, New York	95354 Methode Mfg. Corp. Rolling Meadows, Illinois	98291 Sealectro Corp. Mamaroneck, New York
90211 Use 56365 Square D Co. Chicago, Illinois	91929 Honeywell Inc. Micro Switch Div. Freeport, Illinois	95712 Bendix Corp. Electrical Components Div. Microwave Devices Plant Franklin, Indiana	98388 Royal Industries Products Div. San Diego, California
90215 Best Stamp & Mfg. Co. Kansas City, Missouri	91934 Miller Electric Co., Inc. Div. of Aunet Woonsocket, Rhode Island	95987 Weckesser Co. Inc. Chicago, Illinois	98743 Replaced by 12749
90303 Mallory Battery Co. Div. of Mallory Co., Inc. Tarrytown, New York	92194 Alpha Wire Corp. Elizabeth, New Jersey	96733 San Fernando Electric Mfg. Co. San Fernando, California	98925 Replaced by 14433
91094 Essex International Inc. Suglex/IWP Div. Newmarket, New Hampshire	93332 Sylvania Electric Products Semiconductor Products Div. Woburn, Massachusetts	96853 Gulton Industries Inc. Measurement and Controls Div. formerly Rustrak Instruments Co. Manchester, New Hampshire	99120 Plastic Capacitors, Inc. Chicago, Illinois
91293 Johanson Mfg. Co. Boonton, New Jersey	94145 Replaced by 49956	96881 Thomson Industries, Inc. Manhasset, New York	99217 Bell Industries Elect. Comp. Div. formerly Southern Elect. Div. Burbank, California
91407 Replaced by 58474	94154 Use 94988 Wagner Electric Corp. Tung-Sol Div. Newark, New Jersey	97540 Master Mobile Mounts, Div. of Whitehall Electronics Corp. Ft. Meyers, Florida	99392 STM Oakland, California
91502 Associated Machine Santa Clara, California	94222 Southco Inc. formerly South Chester Corp. Lester, Pennsylvania	97913 Industrial Electronic Hardware Corp. New York, New York	99515 ITT Jennings Monrovia Plant Div. of ITT Jennings formerly Marshall Industries Capacitor Div. Monrovia, California
91506 Augat Inc. Attleboro, Massachusetts	95146 Alco Electronic Products Inc. Lawrence, Massachusetts	97945 Penwalt Corp. SS White Industrial Products Div. Piscataway, New Jersey	99779 Use 29587 Bunker-Ramo Corp. Barnes Div. Landsdowne, Pennsylvania
91637 Dale Electronics Inc. Columbus, Nebraska	95263 Leecraft Mfg. Co. Long Island City, New York	97966 Replaced by 11358	99800 American Precision Industries Inc. Delevan Division East Aurora, New York
91662 Elco Corp. Willow Grove, Pennsylvania	95264 Replaced by 98278	98094 Replaced by 49956	99942 Centrelab Semiconductor Centrelab Electronics Div. of Globe-Union Inc. El Monte, California
91737 Use 71468 Gremar Mfg. Co., Inc. ITT Cannon/Gremar Santa Ana, California	95275 Vitramon Inc. Bridgeport, Connecticut	98159 Rubber-Teck, Inc. Gardena, California	Toyo Electronics (R-Ohm Corp.) Irvine, California
91802 Industrial Devices, Inc. Edgewater, New Jersey	95303 RCA Corp. Receiving Tube Div. Cincinnati, Ohio	98278 Malco A Microdot Co., Inc. Connector & Cable Div. Pasadena, California	National Connector Minneapolis, Minnesota
91833 Keystone Electronics Corp. New York, New York	95348 Gordo's Corp. Bloomfield, New Jersey		

U.S. SALES OFFICES for all Fluke products

AK, Anchorage

Harry Lang & Associates
1371 Hillcrest Drive #303
Anchorage, AK 99503
(907) 279-5741

AL, Huntsville

John Fluke Mfg. Co., Inc.
3322 Memorial Parkway
Huntsville, AL 35801
(205) 881-6220
(404) 396-3224 (Atlanta)

AZ, Tempe

John Fluke Mfg. Co., Inc.
1215 S. 48th Street
Suite 104
Tempe, AZ 85282
(602) 967-8724
(602) 790-9881 (Tucson)

CA, Los Angeles

John Fluke Mfg. Co., Inc.
20902 South Bonita St.
Carson, CA 90746
(213) 538-3900 or
(714) 761-2449

CA, Santa Clara

John Fluke Mfg. Co., Inc.
2300 Walsh Ave., Bldg. K
Santa Clara, CA 95050
(408) 727-0513

CA, Tustin

John Fluke Mfg. Co., Inc.
15445 Red Hill Ave., Suite F
Tustin, CA 92680
(714) 838-8863
(714) 226-1254 (San Diego)

CO, Denver

John Fluke Mfg. Co., Inc.
1980 South Quebec St. #4
Denver, CO 80231
(303) 750-1222

CT, Hartford

John Fluke Mfg. Co., Inc.
124 Hebron Ave.
Glastonbury, CT 06033
(203) 633-0777

FL, Orlando

John Fluke Mfg. Co., Inc.
940 N. Fern Creek Ave.
Orlando, FL 32803
(305) 896-4881

HI, Honolulu

EMC Corporation
2979 Ualena St.
Honolulu, HI 96819
(808) 836-1138

IA, Iowa City

John Fluke Mfg. Co., Inc.
1027 Hollywood Blvd., #309
Iowa City, IA 52240
(319) 354-2811

IL, Chicago

John Fluke Mfg. Co., Inc.
1400 Hicks Road
Rolling Meadows, IL 60008
(312) 398-0850

IN, Indianapolis

John Fluke Mfg. Co., Inc.
5610 Crawfordsville Rd.
Suite 802
Indianapolis, IN 46224
(317) 244-2456

KA, Kansas City

John Fluke Mfg. Co., Inc.
4550 West 109th St.
Suite 130
Shawnee Mission, KA 66211
(913) 381-9800

MA, Burlington

John Fluke Mfg. Co., Inc.
25 "B" Street
Burlington MASS
(617) 273-4674

MD, Rockville

John Fluke Mfg. Co., Inc.
5640 Fishers Lane
Rockville, MD 20852
(301) 770-1570
(301) 792-7060 (Baltimore)

MI, Detroit

John Fluke Mfg. Co., Inc.
13955 Farmington Rd.
Livonia, MI 48154
(313) 522-9140

MN, Minneapolis

John Fluke Mfg. Co., Inc.
7373 West 147th Street
Suite 196
Apple Valley, MN 55124
(612) 432-9400

MO, St. Louis

John Fluke Mfg. Co., Inc.
300 Brookes Dr., Suite 100
Hazelwood, MO 63042
(314) 731-3388

NC, Greensboro

John Fluke Mfg. Co., Inc.
1310 Beaman Place
Greensboro, NC 27408
(919) 273-1918

NJ, Paramus

John Fluke Mfg. Co., Inc.
P.O. Box 930
West 75 Century Road
Paramus, NJ 07652
(201) 262-9550

NM, Albuquerque

John Fluke Mfg. Co., Inc.
1108 Alvarado Drive N.E.
Albuquerque, NM 87110
(505) 265-8431

NY, Rochester

John Fluke Mfg. Co., Inc.
4515 Culver Road
Rochester, NY 14622
(716) 266-1400

OH, Cleveland

John Fluke Mfg. Co., Inc.
7830 Freeway Circle
Middleburg Heights, OH 44130
(216) 234-4540

OH, Dayton

John Fluke Mfg. Co., Inc.
4756 Fishburg Rd.
Dayton, OH 45424
(513) 233-2238

OR, Portland

John Fluke Mfg. Co., Inc.
18360 S.W. Springfield Lane
Aloha, OR 97007
(503) 642-1342

PA, Philadelphia

John Fluke Mfg. Co., Inc.
1010 West 8th Ave., Suite H
King of Prussia, PA 19406
(215) 265-4040
(412) 261-5171 (Pittsburgh)

TX, Austin

John Fluke Mfg. Co., Inc.
111 W. Anderson Lane
Suite 213
Austin, TX 78752
(512) 478-9901
(512) 340-2621 (San Antonio)

TX, Dallas

John Fluke Mfg. Co., Inc.
14400 Midway Road
Dallas, TX 75234
(214) 233-9990

TX, Houston

John Fluke Mfg. Co., Inc.
1014 Wirt Road, Suite 270
Houston, TX 77055
(713) 683-7913

UT, Salt Lake City

John Fluke Mfg. Co., Inc.
782 East 8325 Street
Sandy, UT 84070
(801) 566-4864

WA, Seattle

John Fluke Mfg. Co., Inc.
975 Industry Drive
Seattle, WA 98188
(206) 575-3765

For more information on Fluke products or Sales Offices you may dial (800) 426-0361 toll-free in most of U.S.
From Alaska, Hawaii, or Washington, phone (206) 774-2481. From other countries phone (206) 774-2398.

INTERNATIONAL SALES OFFICES

Argentina •

Coasin, S.A.
Virrey del Pino 4071
Buenos Aires, Argentina
Tel: 525130, TLX: 390122284

Australia •

Elmeasco Instruments Pty Ltd.
P.O. Box 30, Concord, N.S.W.
Australia 2137
Tel: (2) 736-2888, TLX: 79025887

Elmeasco Instruments Pty Ltd.
P.O. Box 107

Mt. Waverly, VIC. 3149

Australia

Tel: 233-4044

TLX: 36206 (ELMVIC)

Elmeasco Instruments Pty Ltd.
Professional Suite's Bldg.
B.P.O. Box 2360

Brisbane, 4001, Australia

Tel: (07) 229-3161

Elmeasco Instruments Pty Ltd.

P.O. Box 1240

G.P.O. Adelaide 5001

South Australia

Elmeasco Instruments Pty. Ltd.

P.O. Box 95, Gosnells

West Australia 6110

Tel: (09) 348-3362

Austria ■

Walter Rekirsch
Elektronische Gerate GmbH & Co.
Vertriebs-KG., Obachgasse 28
A-1220 Vienna, Austria
Tel: (0222) 23555 TLX: 134759

Belgium ■

Fluke (Belgium) S.A./N.V.
6, Rue de Geneve
1140 Brussels, Belgium
Tel: (2) 2164090, TLX: 26312

Bolivia •

Coasin Bolivia S.R.L.
Casilla 7295, La Paz, Bolivia
Tel: 40962

Brazil •

Arotec S.A.
Industria e Comercio
Av. Pacaembu 811
01234 Sao Paulo S.P., Brazil
Tel: (011) 826-2266, TLX: 1122207

Arotec S.A.
Rua Araguari, 1705 s/402
30.000 Belo Horizonte M.G., Brazil
Tel: 335-7735

Arotec S.A.
Av. Rio Branco, 277, Grupo 1309
02000 Rio de Janeiro, R.J., Brazil
Tel: (021) 242-9776

Brunei •

Rank O'Connor's (PTE) Limited
No. 8, BK.D
Surfiri Shop House Complex
Mile 1, Jalong Tutong
Bandar Seri Begawan, Brunei
Tel: 26680

Bulgaria ■

Amtest Associates Ltd.
P.O. Box 55
Addlestone, Surrey KT15 1DU
United Kingdom
Tel: Weybridge (932) 52121
TLX: 928855

Canada •

Allan Crawford Assoc., Ltd.
#14 1935 30th Ave. N.E.
Calgary, Alberta T2E 6Z5
Tel: (403) 230-1341

Allan Crawford Assoc., Ltd.
3795 William Street
Burnaby, British Columbia V5C 3H3
Tel: (604) 294-1326

Allan Crawford Assoc., Ltd.
192 Joseph Zatzman Dr.
Suite 4

Burnside Industrial Park
Dartmouth, Nova Scotia B3B 1N4
Tel: (902) 463-9360

Allan Crawford Assoc., Ltd.
881 Lady Ellen Place
Ottawa, Ontario K1Z 5L3
Tel: (613) 722-7682

Allan Crawford Assoc., Ltd.
6503 Northam Drive
Mississauga, Ontario L4V 1J5
Tel: (416) 678-1500

Allan Crawford Assoc., Ltd.
7018 cote de Liesse
St. Laurent, Quebec H4T 1E7
Tel: (514) 731-8564

Chad ■

Fluke (Holland) B.V.
P.O. Box 5053, Zevenhevelenweg 53
5004 EB Tilburg, Netherlands
Tel: (013) 673973, TLX: 52237

Chile •

Intronica Chile Ltda.
Manuel Montt 024 - Of. D
Casilla 16228, Santiago 9, Chile
Tel: 44940
TLX: No 40301 Cab. Publ.,
Attn: Intronica Chile

China, People's Republic of •

Fluke International Corporation
P.O. Box 43210
Mountlake Terrace, WA 98043
Tel: (206) 774-2398
TLX: 152662 JOHNFLUKE MTLT

Colombia •

Coasin Ltda.
Carrera 13, No. 37-37, Of. 401
Ap. Aero 29583
Bogota DE, Colombia
Tel: 232-45-32, TLX: 45787

Cyprus ■

Chris Radiovision Ltd.
P.O. Box 1989, Nicosia, Cyprus
Tel: 66121, TLX: 2395

Czechoslovakia ■

Amtest Associates Ltd.
P.O. Box 55
Addlestone, Surrey KT15 1DU
United Kingdom
Tel: Weybridge (932) 52121
TLX: 928855

Denmark ■

Tage Olsen A/S
Ballerup Byvej 222
DK - 2750 Ballerup, Denmark
Tel: (2) 658111, TLX: 35293

Ecuador •

Proteco Coasin Cia., Ltda.
Edificio "Jerico"
Ave. 12 de Octubre #2285 y
Ave. Orellana (Planta Baja)
Quito, Ecuador
Tel: 529684, TLX: 2865 Protec Ed

Proteco Coasin Cia., Ltda.
Calderon 103Y Malecon
Casilla #9733
Guayaquil, Ecuador
Tel: 526093

Egypt and Sudan ■

Lotus Engineering Organisation
P.O. Box 1252
22, Kaft El Nil
Cairo, Egypt
Tel: 971617, TLX: 92504

Eire (Republic of Ireland) ■

EURO Electronics
32 Brews Hill
Naven, County Meath, Ireland
Tel: 46-23577, TLX: 3182

Ethiopia ■

Fluke (Holland) B.V.
P.O. Box 5053, Zevenhevelenweg 53
5004 EB Tilburg, Netherlands
Tel: (013) 673973, TLX: 52237

Finland ■

Oy Findip AB, Teollisuustie 7
02700 Kaunainen, Finland
Puh: (0) 5052255
TLX: 123129

France ■

M.B. Electronique S.A.
Rue Fourny 606, Z1 Centre
78530 BUC
B.P. No. 31
78530 BUC, France
Tel: (3) 9568131, TLX: 695414

German Democratic Republic ■

Amtest Associates Ltd.
P.O. Box 55
Addlestone, Surrey KT15 1DU
United Kingdom
Tel: Weybridge (932) 52121
TLX: 928855

German Federal Republic ■

Fluke (Deutschland) GmbH
Max-Hueber StraBe 8
8045 Ismaning, West Germany
Tel: (089) 96251, TLX: 522472
Rapifax: (089) 966718

Fluke (Deutschland) GmbH
MeineckestraBe 53
4000 Dusseldorf 30, West Germany
Tel: (0211) 450831, TLX: 8585576

Fluke (Deutschland) GmbH
Oberer Kirchhaldenweg 135
7000 Stuttgart 1, West Germany
Tel: (0711) 694091, TLX: 722518

Fluke (Deutschland) GmbH
Hubertusallee 46
1000 Berlin-33, West Germany
Tel: (030) 8911090
TLX: 0184978

Greece ■

Hellenic Scientific Representations Ltd.
11, Vrasside Street
Athens 615, Greece
Tel: (1) 711140, TLX: 219330

Hong Kong •

Schmidt & Co. (H.K.) Ltd.
28th Fl. Wing on Centre
111 Connaught Road
Central Hong Kong
Tel: 5-455644
TLX: 74766 SCHMC HX

Hungary ■

Amtest Associates Ltd.
P.O. Box 55
Addlestone, Surrey KT15 1DU
United Kingdom
Tel: Weybridge (932) 52121
TLX: 928855

Iceland •

Kristjan O. Skagfjord Ltd.
P.O. Box 906
Reykjavik, Iceland
Tel: 24120, TLX: 2133

India •

Hinditron Services Pvt. Ltd.
69/A.L. Jagmohandas Marg
Bombay 400 006, India
Tel: 811316,
TLX: 953-112326 Hspl In

Hinditron Services Pvt. Ltd.
33/44-A 8th Main Road
Raj Mahl Vilas Extension
Bangalore 560 080, India
Tel: 33139
TLX: 0845741

Hinditron Services Pvt. Ltd.
Shantiniketan, Office No.6
6th Floor, 8 Camac Street
Calcutta 700 017, India
Tel: 434032, 447541

Hinditron Services Pvt. Ltd.
15 Community Centre, Panchshila Park
New Delhi 110 017, India
Tel: 619118

Hinditron Services Pvt. Ltd.
Srinath Complex, 5th Floor
1-1-58/1 to 1-1-58/11
Sarojini Devi Road
Secunderabad 500 003, India
Tel: 61705

Indonesia •

P.T. Dwi Tunggal Jaya Sakti
Sangga Buana Bldg., 1st Floor
Jl. Senen Raya 44, P.O. Box 4435
Jakarta, Indonesia
Tel: 367390-9, TLX: 46624

Iran ■

Irantronics Company Ltd.
20, Salm Road
Roosevelt Avenue, Tehran, Iran
Tel: 828294/831564
TLX: 212956

Iraq ■

Fluke (Holland) B.V.
P.O. Box 5053, Zevenhevelenweg 53
5004 EB Tilburg, Netherlands
Tel: (013) 673973, TLX: 52237

Ireland ■

Euro Electronics
32 Brews Hill
Naven County Meath, Ireland
Tel: (46) 23577, TLX: 3182

Israel ■

R.D.T. Electronics Engineering Ltd.
P.O. Box 75
46, Sokolov Street
Ramat Hasharon 47235, Israel
Tel: (3) 483212, TLX: 32143



Italy ■

Sistrel S.p.A.
Via Giuseppe Armellini No. 37
00143 Rome, Italy
Tel: (6) 5915551, TLX: 68356

Sistrel S.p.A.
Via Pelizza da Volpedo 59
20092 Cinisello besamo
Milan, Italy
Tel: (2) 6181893, TLX: 334643

Sistrel S.p.A.
Via Cintia Parco S. Paolo 35
80126 Naples, Italy
Tel: (81) 7679700

Japan ●

John Fluke Mfg. Co., Inc.
Japan Branch
(PC Board Testers only)
1 Higashikata-machi
Midori-ku

Yokohama 226, Japan
Tel: (045) 473-5425
TLX: 3823-666 FLKJJP

Tokyo Electron Ltd.
38 FL Shinjuku Nomura Bldg.
1-26-2, Nishi-Shinjuku
Shinjuku-ku
Tokyo 160, Japan
Tel: 03-343-4411, TLX: 2322220

Kenya ●

ADCOM Ltd.
P.O. Box 30070
Nairobi, Kenya, East Africa
Tel: 331955, TLX: 22639

Korea ●

Electro-Science Korea Co.
C.P.O. Box 8446
Rm. 501, Boondo Bldg.
56-12 Jangchung-IKa
Jung-ku
Seoul, Korea
Tel: 261-7702, TLX: K25381

Kuwait ■

Tareq Company
P.O. Box Safat 20506
Kuwait, Arabian Gulf
Tel: 436100/436045
TLX: 2315

Lebanon and Jordan ■

Mabek (Electronics Division)
P.O. Box 11-3823
Beirut, Lebanon
Tel: 252631/348728
TLX: 22889

Libya ■

Fluke (Holland) B.V.
P.O. Box 5053, Zevenhevelenweg 53
5004 EB Tilburg, Netherlands
Tel: (013) 673973, TLX: 52237

Malaysia ●

Rank O'Connor's (PTE) Limited
P.O. Box 91, Petaling Jaya
Selangor, West Malaysia
Tel: 566599
TLX: OCONOR MA37649

Rank O'Connor's (PTE) Limited
Lot No. 5 Taman Mesra
Mile 3, Jalan Penampang
Kota Kinabulu, East Malaysia
Tel: 55322, TLX: MA80286

Mexico ●

Christensen S.A. De C.V.
Instrumentos Electronicos de Medicion
Melchor Ocampo 150-8
Mexico 4 D.F., Mexico
Tel: (905) 535-2258
TLX: 1775612

Morocco ■

Mainvest
Residence Moulay Ismail, Bat. C.
12, Place des Alaouites
Rabat, Morocco
Tel: (7) 23990, TLX: 31036

Netherlands ■

Fluke (Nederland) B.V.
Zonneban 39
3606 CH Maarssen
P.O. Box 225
3600 AE Maarssen
Tel: (030) 436514, TLX: 47128

New Zealand ●

W & K McLean Ltd.
P.O. Box 18065, Glen Innes
Auckland, New Zealand
Tel: 587-037
TLX: N.Z. 7912763

W & K McLean Ltd.
P.O. Box 2421
Christchurch, New Zealand
Tel: 851-450

W & K McLean Ltd.

P.O. Box 496
Wellington, New Zealand
Tel: 851-450

Nigeria ●

Mofat Engineering Co., Ltd.
P.O. Box 6369
Lagos, Nigeria
Tel: 21353, Attn: MOFAT

Norway ■

Morgenstjerne & Co A/S
Konghellegate 3/5
P.O. Box 6688, Rodelokka
Oslo 5, Norway
Tel: (2) 356110, TLX: 11719

Pakistan ●

Pak International Operations
505 Muhammadi House
I.I. Chundrigar Road
P.O. Box 5323, Karachi, Pakistan
Tel: 221127, TLX: 24494

PDR Yemen ■

Fluke (Holland) B.V.
P.O. Box 5053, Zevenhevelenweg 53
5004 EB Tilburg, Netherlands
Tel: (013) 673973, TLX: 52237

Peru ●

Importaciones Y Representaciones
Electronicas S.A.
Avda. Franklin D. Roosevelt 105
Lima 1, Peru
Tel: 288650, TLX: 37425663

Philippines ●

Spark Radio & Electric Supply
P.O. Box 610, Greenhills, San Juan
M. Manila, Philippines
Tel: 78-78-16
TLX: 27901 RLA PH

Poland ■

Amtest Associates Ltd.
P.O. Box 55
Addlestone, Surrey KT15 1DU
United Kingdom
Tel: Weybridge (932) 52121
TLX: 928855

Portugal ■

Decada-Equipamentos
de Electronica, Lda.
P.O. Box 1128, 1003
Lisbon Codex, Portugal
Tel: (1) 574984, TLX: 18469

Qatar ■

Technology Organisation
P.O. Box 5549, Doha, Qatar
Tel: 321431, TLX: 4581

Romania ■

Amtest Associates Ltd.
P.O. Box 55
Addlestone, Surrey KT15 1DU
United Kingdom
Tel: Weybridge (932) 52121
TLX: 928855

Saudi Arabia ■

Electronic Equipment Marketing Co. Ltd.
P.O. Box 3750
Riyadh, Saudi Arabia
Tel: 4032761, TLX: 201120

Singapore ●

Rank O'Connor's (PTE) Limited
98 Pasir Panjang Road
Singapore 0511
Republic of Singapore
Tel: 637944
TLX: OCONSIN RS21023

Somalia ■

Fluke (Holland) B.V.
P.O. Box 5053, Zevenhevelenweg 53
5004 EB Tilburg, Netherlands
Tel: (013) 673973, TLX: 52237

South Africa ●

Fluke S.A. (Pty) Ltd.
P.O. Box 39797, Bramley 2018
Republic of South Africa
Tel: (011) 786-3170, TLX: 424328

Spain ■

Hispano Electronica S.A.
Piligono Industrial Urtinsa
Apartado de Correos 48
Alcorcon (Madrid), Spain
Tel: (1) 6194108
TLX: 22404/42634

Sweden ■

Teleinstrument AB
P.O. Box 4490
162 04 Vallingby, Sweden
Tel: (8) 380370, TLX: 11347

Switzerland ■

Traco Electronic Company Ltd.
Jenatschstrasse 1
8002 Zurich, Switzerland
Tel: (1) 2010711, TLX: 54318

Syria ■

Mabek (Electronics Division)
P.O. Box 4238
Damascus, Syria

Taiwan ●

CCT Associates, Inc.
P.O. Box 32-79
Taipei, Taiwan, Republic of China
Tel: (02) 391-6894,
TLX: 24263 Longgulf

Thailand ●

Dynamic Supply Engineering R.O.P.
12 SOI, Pasana 1, Ekami Sukhumvit 63
Bangkok-11, Thailand
Tel: 3925313
TLX: TH 82938 MONTIEN TH

Tunisia ■

Selep S.A.R.L.
6, Rue de Sparte
Tunis - 1000 RP, Tunisia
Tel: (1) 248093, TLX: 13030

Turkey ■

Erkmen Elektronik Aletler
Ticaret Anonim Sirketi
Necatibey Cad 92/3
Karakoy, Istanbul, Turkey
Tel: (1) 5461
TLX: 23353

United Arab Emirates & Oman ■

Haris A1-Afag Ltd.
P.O. Box 545
Sharajah, United Arab Emirates
Tel: 35912/359121/359122/359123
TLX: 23966

United Kingdom ■

Fluke (G B) Ltd.
Colonial Way
Watford, Herts, WD2 4TT
United Kingdom
Tel: (0923) 40511, TLX: 934583
Rapifax: (0923) 25067

Uruguay ●

Coasin Uruguay S.R.L.
Cuareim 2196
Casilla de Correos 1400
Correo Central
Montevideo, Uruguay
Tel: 29-31-95, TLX: 37425663

U.S.S.R. ■

Amtest Associates Ltd.
P.O. Box 55
Addlestone, Surrey KT15 1DU
United Kingdom
Tel: Weybridge (932) 52121
TLX: 928855

Venezuela ●

Coasin, C.A.
Calle 9 Con Calle 4, Edif. Edinurbi
Piso 3, La Urbina
Apartado De Correos NR-70.136 Los Ruices
Caracas 1070A, Venezuela
Tel: 38-78-42, TLX: 2102

Yemen ■

Fluke (Holland) B.V.
P.O. Box 5053, Zevenhevelenweg 53
5004 EB Tilburg, Netherlands
Tel: (013) 673973, TLX: 52237

Yugoslavia ■

Amtest Associates Ltd.
P.O. Box 55
Addlestone, Surrey KT 15 1DU
United Kingdom
Tel: Weybridge (932) 52121
TLX: 928855

■ Supplied and Supported by —

Fluke (Holland) B.V.
P.O. Box 5053, Zevenhevelenweg 53
5004 EB Tilburg, Netherlands
Tel: (013) 673973, TLX: 52237

● Supplied and Supported by —

Fluke International Corporation
P.O. Box C9090
Everett, WA 98206
Tel: (206) 356-6300
TLX: 152662 JOHNFLUKE MTLT

● Latin America also supported by —

Sr. Benewaldo Padovani
c/o AROTEC S.A.
Industria e Comercio
Av. Pacaembu 811
01234 Sao Paulo S.P., Brazil
Tel: (011) 826-2266
TLX: 1122207 AROT BR

TECHNICAL SERVICE CENTERS

U.S. & Canada

CA, Burbank

Fluke Technical Center
2020 N. Lincoln Street
Burbank, CA 91504
(213) 849-4641

CA, Santa Clara

Fluke Technical Center
1980 S. Quebec St., Unit 4
Denver, CO 80231
(303) 750-1228

FL, Orlando

Fluke Technical Center
940 N. Fern Creek Avenue
Orlando, FL 32803
(305) 896-2296

IL, Rolling Meadows

Fluke Technical Center
1400 Hicks Road
Rolling Meadows, IL 60008
(312) 398-5800

MA, Waltham

Fluke Technical Center
25 "B" Street
Burlington, MA 01803
(617) 273-4678

MD, Rockville

Fluke Technical Center
5640 Fishers Lane
Rockville, MD 20852
(301) 770-1576

MN, Apple Valley

Fluke Technical Center
Suite 196
7373 West 147th Street
Apple Valley, MN 55124
(612) 432-7050

NC, Greensboro

Fluke Technical Center
1310 Beaman Place
Greensboro, NC 27408
(919) 273-1918

NJ, Paramus

Fluke Technical Center
West 75th Century Road
Paramus, NJ 07652
(201) 262-9550

TX, Dallas

Fluke Technical Center
14400 Midway Road
Dallas, TX 75240
(214) 233-9945

WA, Mountlake Terrace

Fluke Technical Center
21707 66th Avenue West
Suite 1
Mountlake Terrace, WA 98043
(206) 774-2206

ALB, Calgary

Allan Crawford Assoc., Ltd.
#14 1935 30th Ave. N.E.
Calgary, Alberta T2E 6Z5
(403) 230-1341

ONT, Mississauga

Allan Crawford Assoc., Ltd.
6503 Northam Drive
Mississauga, Ontario L4V 1J2
(416) 678-1500

QUE, Montreal

All Crawford Assoc., Ltd.
7918 Cote de Liesse
Montreal, Quebec H41 1E7
(514) 731-8564

B.C., Burnaby

All Crawford Assoc. Ltd.
795 William St.
Burnaby, B.C. V5C 3H3
(604) 294-1326

Other Areas

Argentina

Fluke Latin American
Service Headquarters
Virrey del Pino 4071
Buenos Aires, Argentina
Tel: 523185

Australia

Elmeasco Instruments Pty Ltd.
P.O. Box 30
Concord, N.S.W.
Australia 2137
Tel: (02) 736-2888

Australia

Elmeasco Instruments Pty. Ltd.
P.O. Box 107
Mr. Waverly, VIC 3149
Australia
Tel: (03) 2334044

Australia

Elmeasco Instruments Pty. Ltd.
GPO Box 2360
Brisbane, Queensland 4001
Australia
Tel: (07) 229-3161

Austria

Walter Rekirsch
Elektronische Gerate GmbH & Co.
Vertriebs-KG.
LiechtensteinstraBe 97/6
A-1090 Vienna, Austria
Tel: 09-43-222-347646

Belgium

Fluke (Belgium) S.A./N.V.
6, Rue de Geneve
1140 Brussels, Belgium
Tel: 09-32-2-2164090

Brazil

Arotec S.A.
Industria e Comercio
Av. Pacaembu 811
01234 Sao Paulo S.P., Brazil
Tel: 826-2266

Chile

Intronica Chile Ltda.
Casilla 16228
Santiago 9, Chile
Tel: 44940

Colombia

Coasin Ltda.
Carrera 13, No. 37-43, Of. 401
Ap. Aero 29583
Bogota DE, Colombia
Tel: 285-0230

Denmark

Tage Olson A/S
Ballerup Byvej 222
DK-2750 Ballerup
Denmark
Tel: (01)2-65 81 11

Ecuador

Proteco Coasin Cia., Ltda.
Edificia "Jerico"
Ave. 12 de Octubre #2285 y
Ave. Orellana (Planta Baja)
Quito, Ecuador
Tel: 526759

Egypt

Lotus Engineering Organisation
P.O. Box 1252
Cairo, Egypt
Tel: 971617

Finland

Oy Findip AB
Teollisuustie 7
02700 Kauniainen
Finland
Tel: 09-358-0-502255

France

M.B. Electronique S.A.
Rue Fourny
ZAC de BUC
B.P. No. 31
78530 BUC, France
Tel: 09-33-1-9568131

Greece

Hellenic Scientific
Representations Ltd.
11, Vrassida Street
Athens 615, Greece
Tel: 09-30-1-711140

Hong Kong

Schmidt & Co (H.K.) Ltd.
28th Fl. Wing On Centre
111 Connaught Road
Central Hong Kong
Tel: 5-455644

India

Hinditron Services Pvt. Ltd.
Field Service Centre
33/44-A, 8th Main Road
Rajmahal Vilas Extn.
Bangalore 560 080, India
Tel: 365344

India

Hinditron Services Pvt. Ltd.
69/A.L. Jagmohandas Marg
Bombay 400 006, India
Tel: 365344

India

Hinditron Services Pvt. Ltd.
15, Community Centre
Panchashila Park
Delhi 110 010, India

Israel

R.D.T. Electronics Engineering Ltd.
P.O. Box 75
46, Sokolov Street
Ramat Hasharon 47235
Israel
Tel: 09-972-3-483211

Italy

Sistrel S.p.A.
Via Pelizza da Volpedo 59
20092 Cinisello Besamo
Milan, Italy
Tel: (2) 6181893

Italy

Sistrel S.p.A.
Via Guiseppe Armellini No. 37
00143 Rome, Italy
Tel: 09-39-6-5915551

Japan

John Fluke Mfg. Co., Inc.
Japan Branch
1 Higashikata-machi
Midori-ku
Yokohama 226, Japan
Tel: (045) 473-5428

Korea

Electro-Science Korea Co.
C.P.O. Box 8446
Rm. 707 Bowon Bldg.
490 Chongro - 5 Ka
Chongro-ku
Seoul, Korea
Tel: 261-7702

Malasia

Rank O'Connor's (Malasia) SDN. BHD.
P.O. Box 91
Petaling Jaya, Selangor
West Malaysia
Tel: 566599

Mexico

C.J. Christensen S.A. De C.V.
Melchor Ocampo 150-8
Mexico 4 D.F., Mexico
Tel: (905) 535-2258

Netherlands

Fluke (Nederland) B.V.
P.O. Box 5053
5004 EB Tilburg
The Netherlands
Tel: 684971

New Zealand

W & K McLean Ltd.
P.O. Box 18065
Glen Innes
Auckland, New Zealand
Tel: 587-037

Norway

Morgenstjerne & Co. A/A
Konghellegate 3
P.O. Box 6688, Rodelokka
Oslo 5, Norway
Tel: 09-47-2-356110

Pakistan

Pak International Operations
505 Mohammadi House
I.I. Chundrigar Road
Karachi-2 Pakistan
Tel: 221127/239052

Peru

Importaciones Y Representaciones
Electronicas S.A.
Avda. Franklin D. Roosevelt 105
Lima 1, Peru
Tel: 288650

Peru

Spark Radio and Electric Supply
P.O. Box 610
Greenhills, San Juan
Metro Manila, Philippines
Tel: 78-78-16

Portugal

Equipamentos de Laboratorio, Ltda.
P.O. Box 1100
Lisbon 1002, Portugal
Tel: 09-351-1-578936/547512

Republic of Singapore

Rank O'Connor's (PTE) Ltd.
98 Pasir Panjang Road
Singapore 0511
Republic of Singapore
Tel: 637944

Republic of South Africa

Fluke S.A. (Pty) Ltd.
P.O. Box 39797
Bramley 2018
Republic of South Africa
Tel: (011) 786-3170

Spain

Hispano Electronica S.A.
Apartado de Correos 48
Alcorcon (Madrid)
Spain
Tel: 09-341694108

Sweden

Teleinstrument AB
P.O. Box 490
S-162 Vallingby 4
Sweden
Tel: -09-46-8-380370

Switzerland

Traco Electronic AG
Jenatschstrasse 1
8002 Zurich
Switzerland
Tel: 09-41-1-2010711

Taiwan

CCT Associates, Inc.
P.O. Box 32-79
Taipei, Taiwan
Republic of China
Tel: (02) 391-6894, 393-5760

Thailand

Dynamic Supply Engineering R.O.P.
12, Soi Pasana 1, Ekami
Sukhumvit 63
Bangkok 11, Thailand
Tel: 3925313

Turkey

Erkman Elektronik Aletler
Ticaret Anonim Sirketi
Necatibey Cad 92/3
Karakoy, Istanbul, Turkey
Tel: 09-44-1-5461

United Kingdom

Fluke (GB) Ltd.
Watford Way
Colindale, Herts, WD2 4TT
United Kingdom
Tel: 09-4492340511

Uruguay

Coasin Uruguaya S.R.L.
Casilla de Correos 1400
Correo Central
Montevideo, Uruguay
Tel: 29-31-95

Venezuela

Coasin C.A.
Calle 9 Con Calle 4
Edif. Edinurbi
Piso 3, La Urbina
Apartado de Correos Nr-70. 136
Los Ruices
Caracas 1070-A, Venezuela
Tel: 387842

West Germany

Fluke (Deutschland) GmbH
Krausstrabe 32
8045 Ismaning
West Germany
Tel: (089) 96251



Section 8

Schematic Diagrams

FIGURE NO.	NAME	DRAWING NO.	PAGE
8-1	DC Voltage Standard (3 sheets)	332B-1001	8-3
8-2	Support Module Assemblies (2 sheets)	332B-1002	8-6
8-3	A2 Sample String	332B-1003	8-8
8-4	Power Distribution Assemblies	332B-1004	8-9

NOTES:

1. RESISTANCE IN OHMS AND CAPACITANCE IN MICROFARADS UNLESS OTHERWISE SPECIFIED.
2. * FACTOR 1 SELECTED COMPONENT.
3. ⊕ INTERNAL ADJUSTMENT
4. ▴ FLAG NOTES WITH SAME NUMBERS ARE COLLECTED. FLAGS WITHOUT TO OR FROM INFORMATION ARE LOCATED ON SAME SHEET.

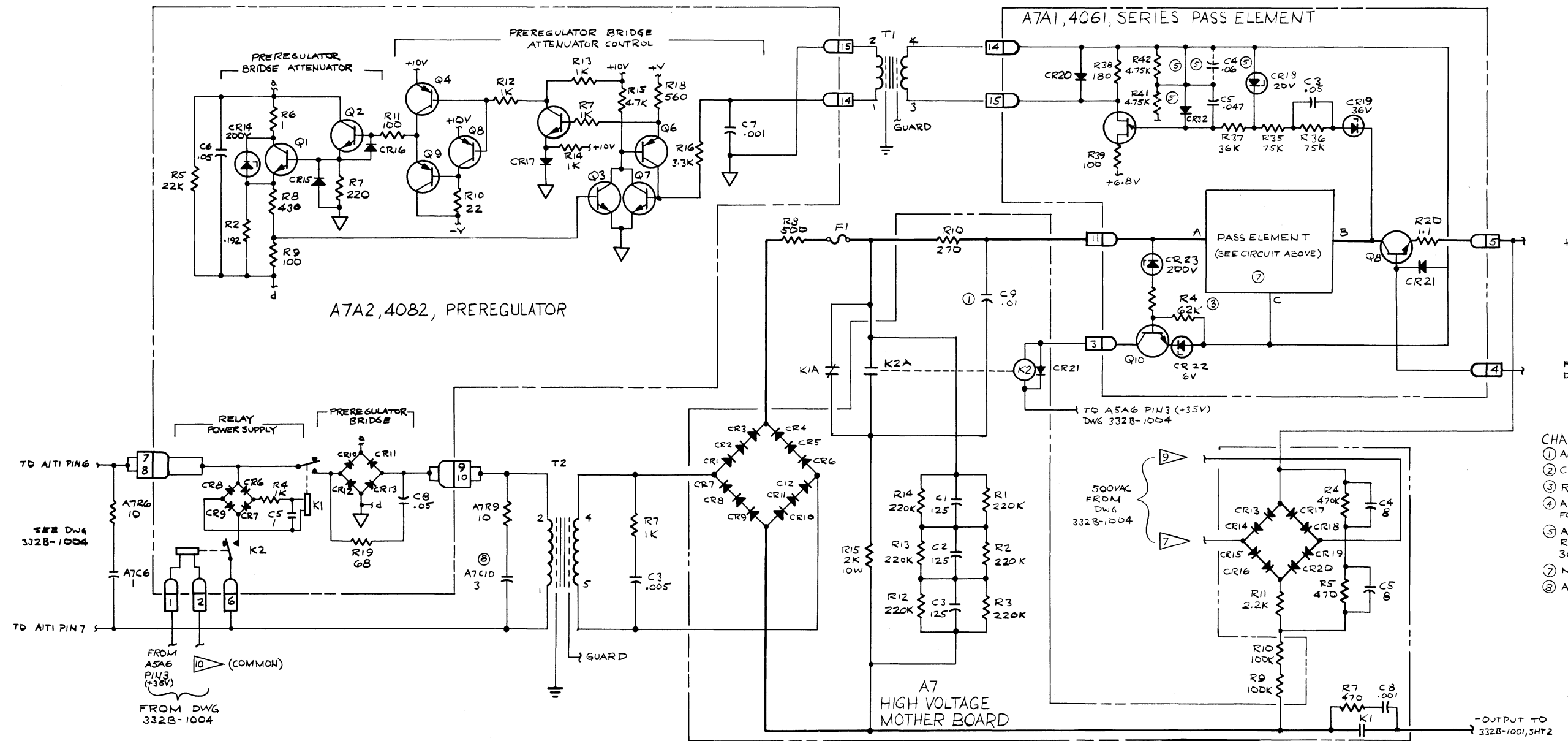
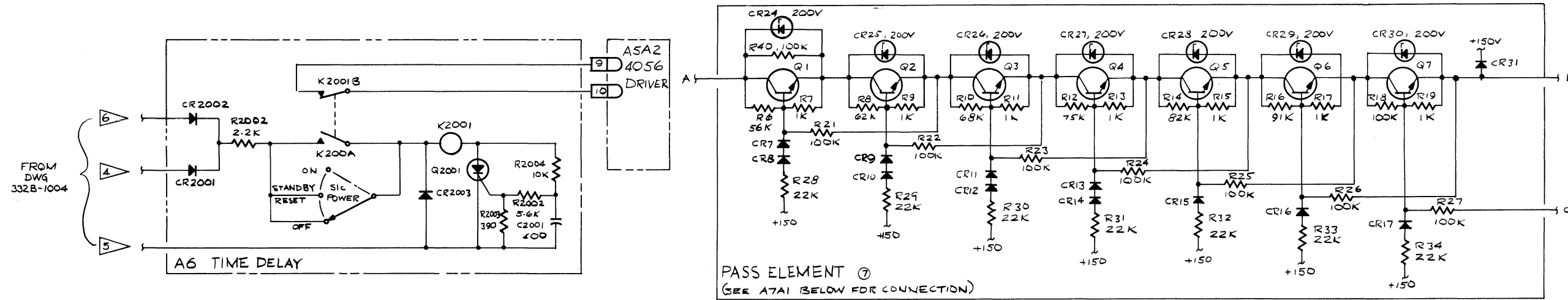

+ OUTPUT TO DWG 332B-1001, SHT 2

FROM ASA2, PIN 4 DWG 332B-1001, SHT 2

CHANGES:

- ① ADDED AT S/N 178 AND ON.
- ② CR15 ADDED AT S/N 179 AND ON.
- ③ R4 WAS 360Ω, R5 WAS 270K, S/N 123 THRU 187.
- ④ ASA2 R21 WAS 220Ω, A7A2 R8 WAS 430Ω FOR S/N 123 THRU 355.
- ⑤ A7A1C4 DELETED, A7A1R4 DELETED, A7A1R42 REPLACED WITH BUSS WIRE, S/N 356, 358, 368, 369, 376 AND ON.
- ⑥ MODIFIED ASSEMBLY ON 332B/AF.
- ⑦ A7C10 CHANGED TO 1μF ON 332B/AF

FIGURE 8-1. (1 of 3) DC VOLTAGE STANDARD (332B-1001)

NOTES:
SEE SHT.

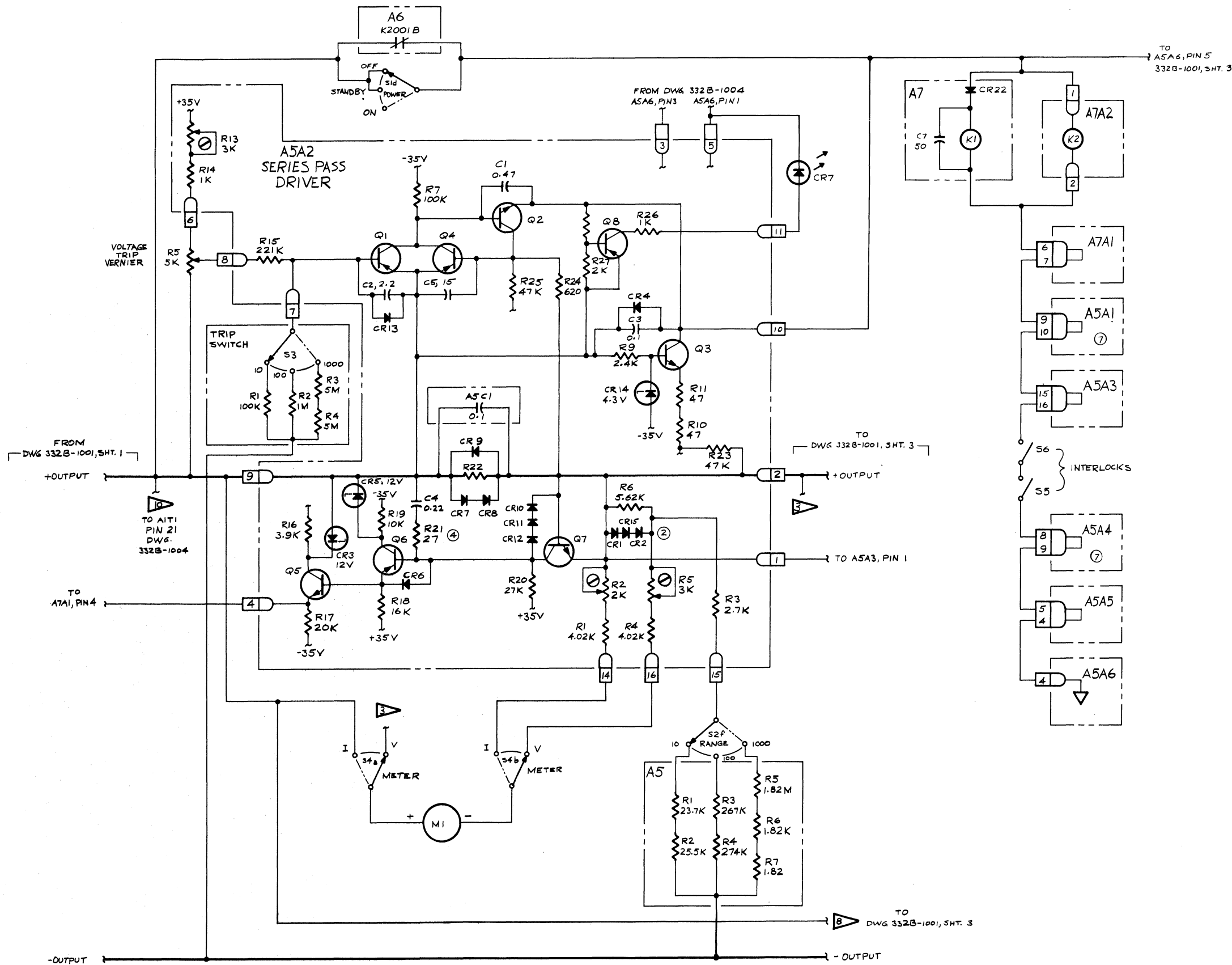

FIGURE 8-1. (2 of 3) DC VOLTAGE STANDARD (332B-1001)

NOTES:
SEE SHT. 1

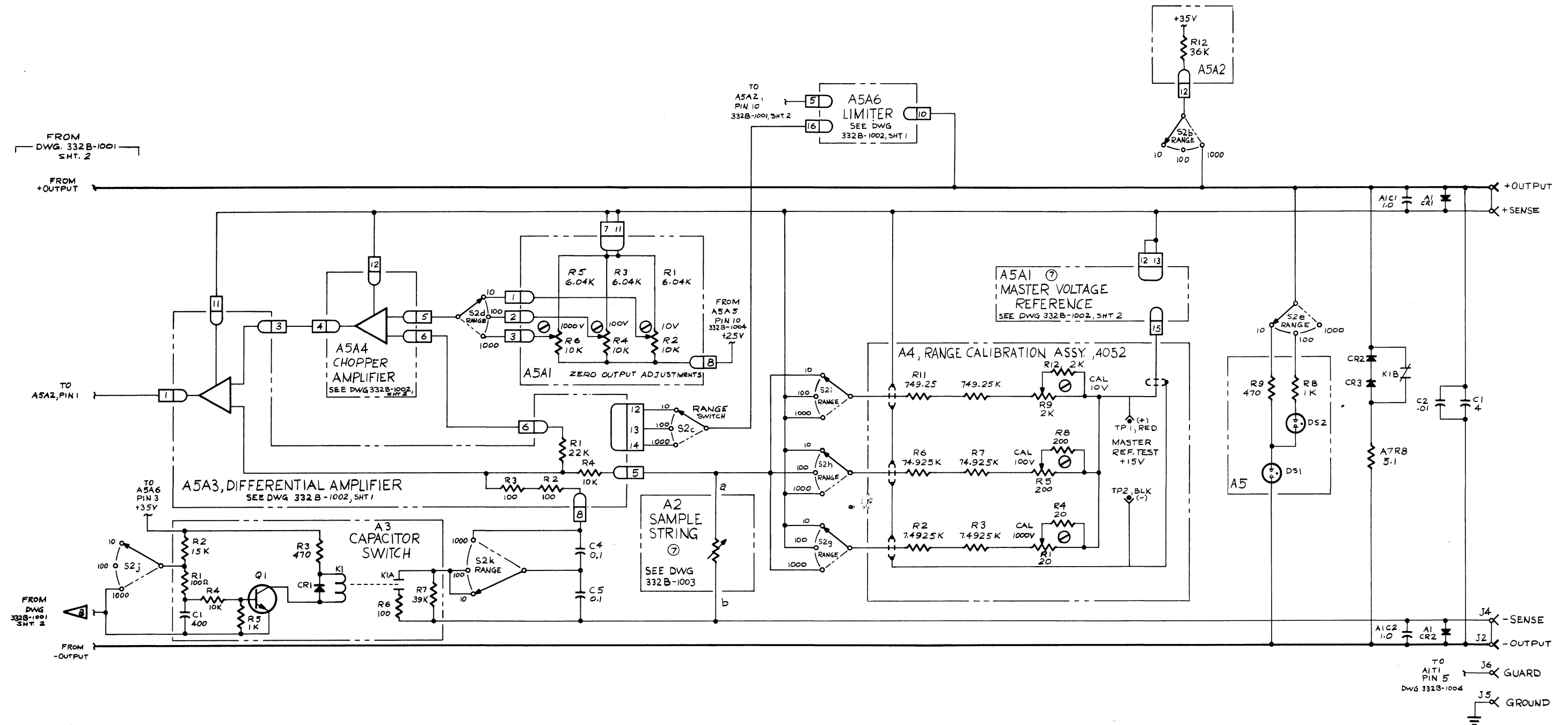
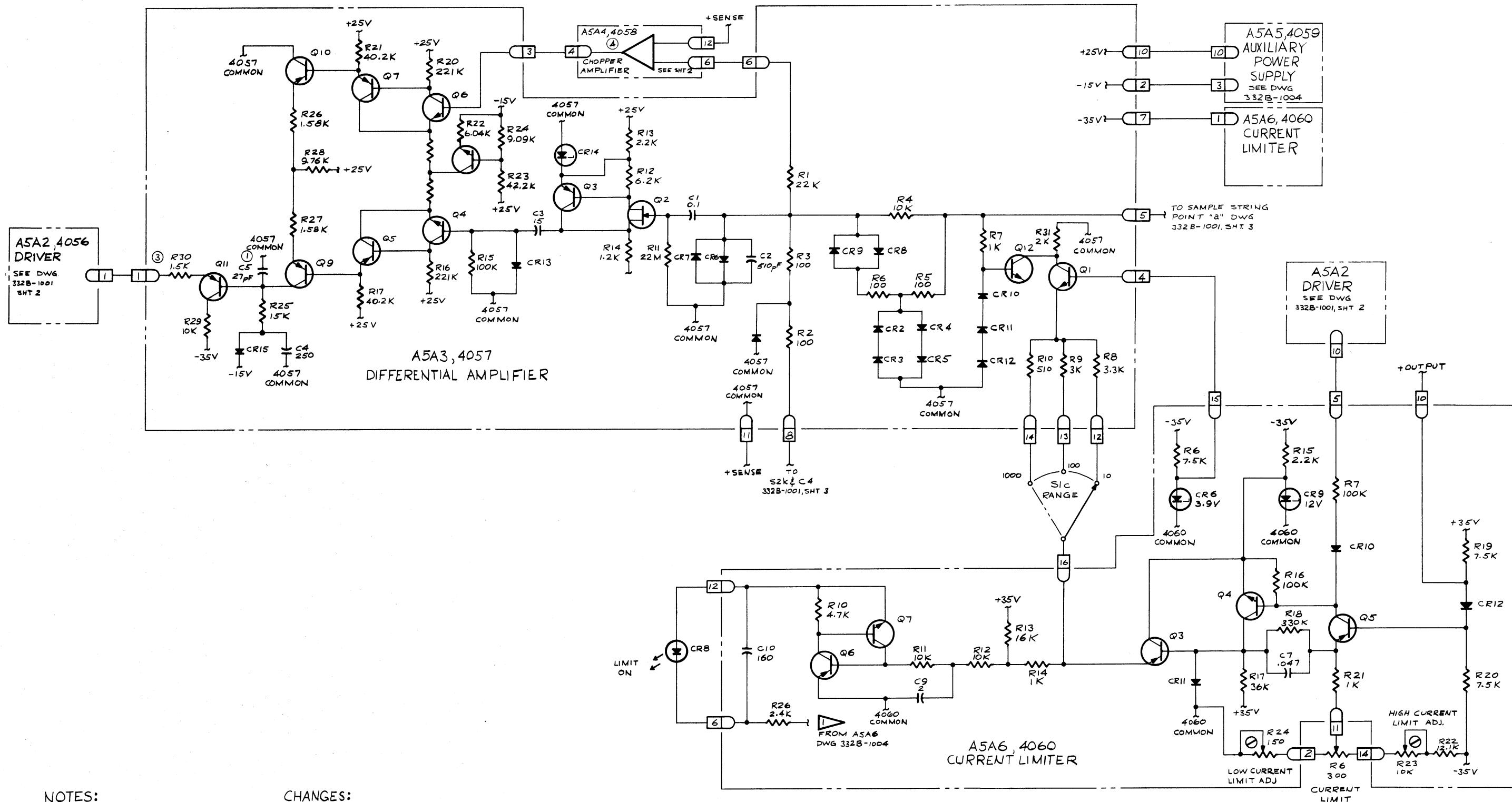

FIGURE 8-1. (3 of 3) DC VOLTAGE STANDARD (332B-1001)



NOTES:

1. RESISTANCE IN OHMS AND CAPACITANCE IN MICROFARADS UNLESS OTHERWISE SPECIFIED.
2. ▷ FLAGS WITH SAME NUMBER ARE CONNECTED.
3. * FACTORY SELECTED COMPONENT.
4. ⊖ INTERNAL ADJUSTMENT

CHANGES:

- ① ASA3 C5 INCLUDED IN S/N 188 THRU 307, 309, 311, 314, 316, 317, 319, 320, 322, 324, 330, 331, & 335.
- ② ASA1C1 ADDED TO S/N 270, 273, 283, 284, 287-296, 298, 300-302, 305, 306 & ON.
- ③ ASA3R30 CHANGED FROM 1K TO 1.5K AT S/N 366 & ON.
- ④ MODIFIED ASSEMBLY ON 332B/AF.

FIGURE 8-2. (1 of 2) SUPPORT MODULE ASSEMBLIES (332B-1002)

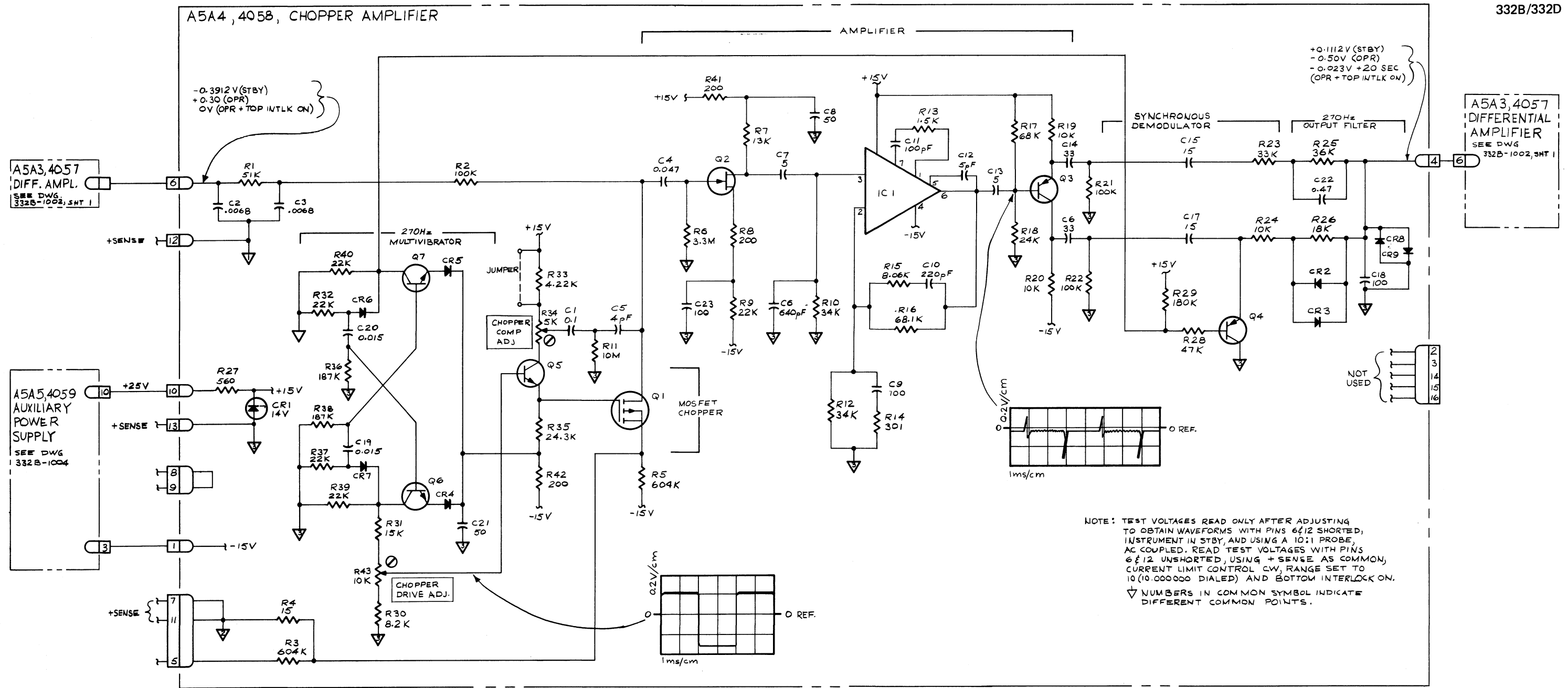

NOTE: TEST VOLTAGES READ ONLY AFTER ADJUSTING TO OBTAIN WAVEFORMS WITH PINS 6 & 12 SHORTED, INSTRUMENT IN STBY, AND USING A 10:1 PROBE, AC COUPLED. READ TEST VOLTAGES WITH PINS 6 & 12 UNSHORTED, USING + SENSE AS COMMON, CURRENT LIMIT CONTROL CW, RANGE SET TO 10 (10.000000 DIALED) AND BOTTOM INTERLOCK ON.
 ▽ NUMBERS IN COMMON SYMBOL INDICATE DIFFERENT COMMON POINTS.

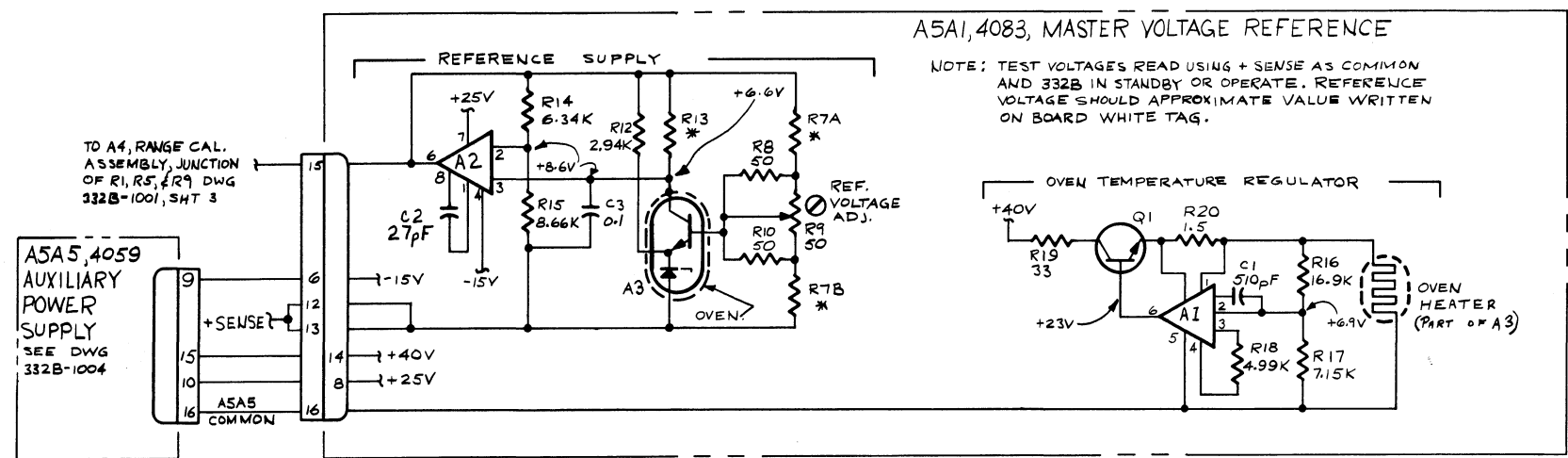

NOTES:
 SEE SHEET 1 FOR NOTES AND CHANGES.

FIGURE 8-2. (2 of 2) SUPPORT MODULE ASSEMBLIES (332B-1002)

TO "a"
DWG
332B-1001, SHT 3

332B/332D

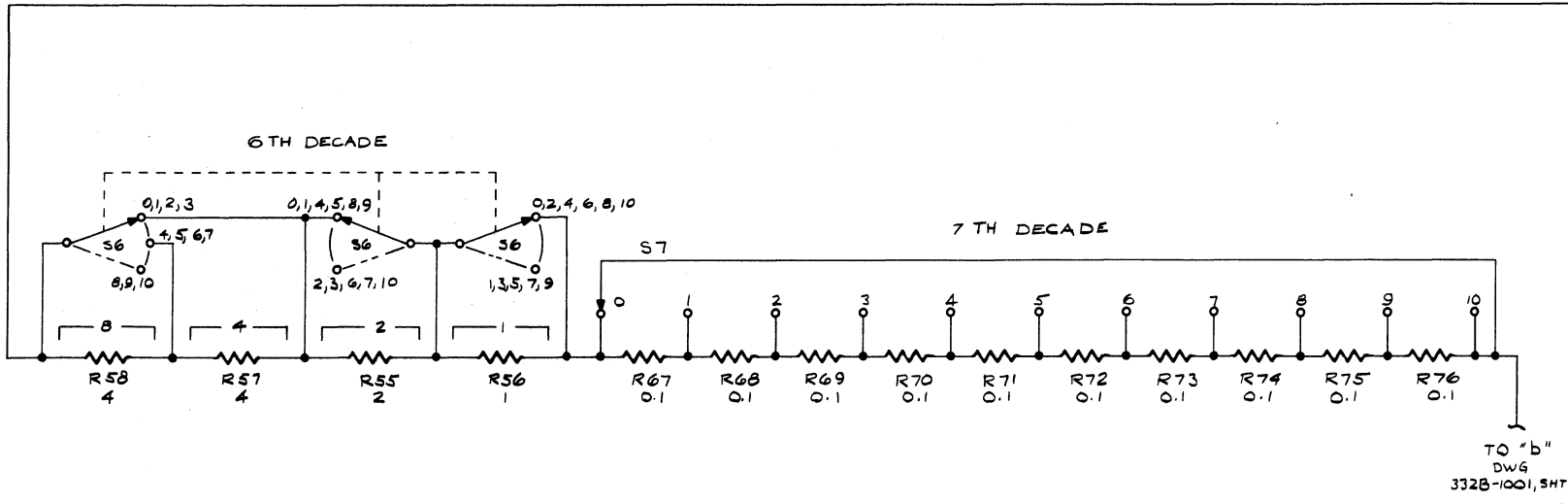
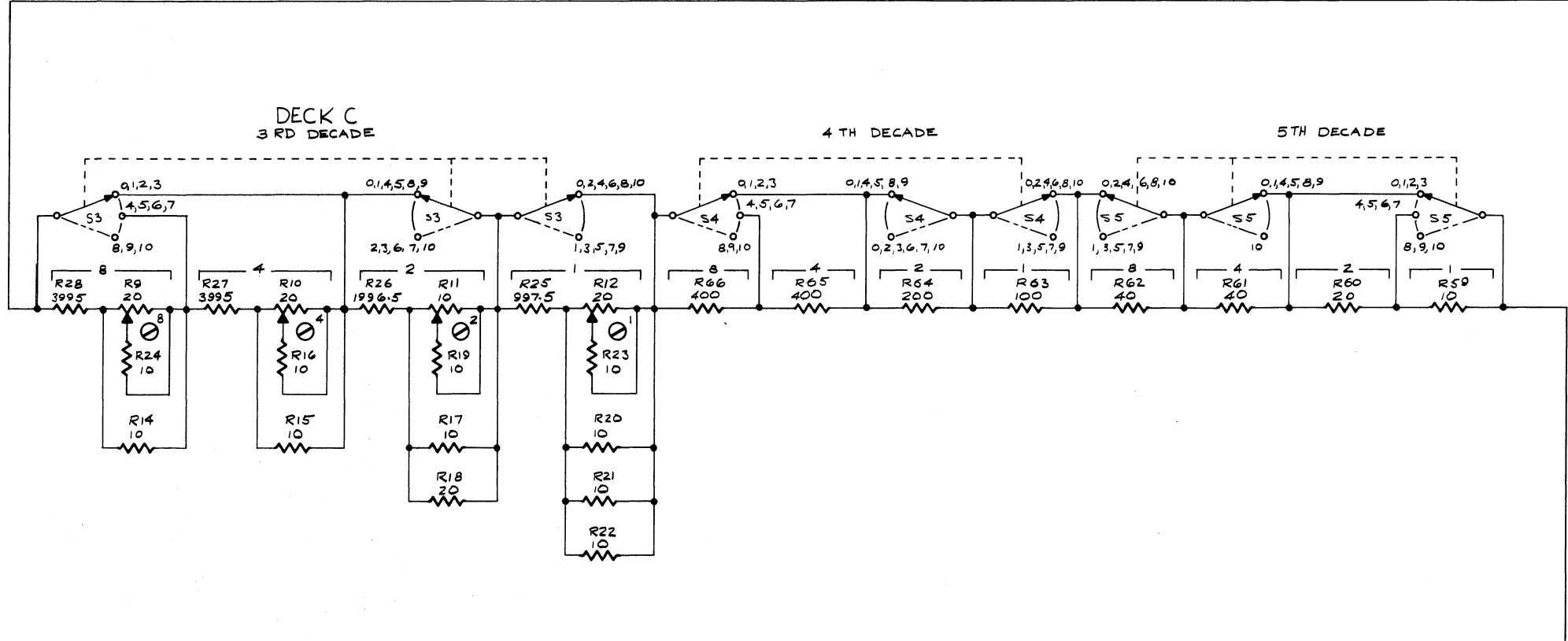
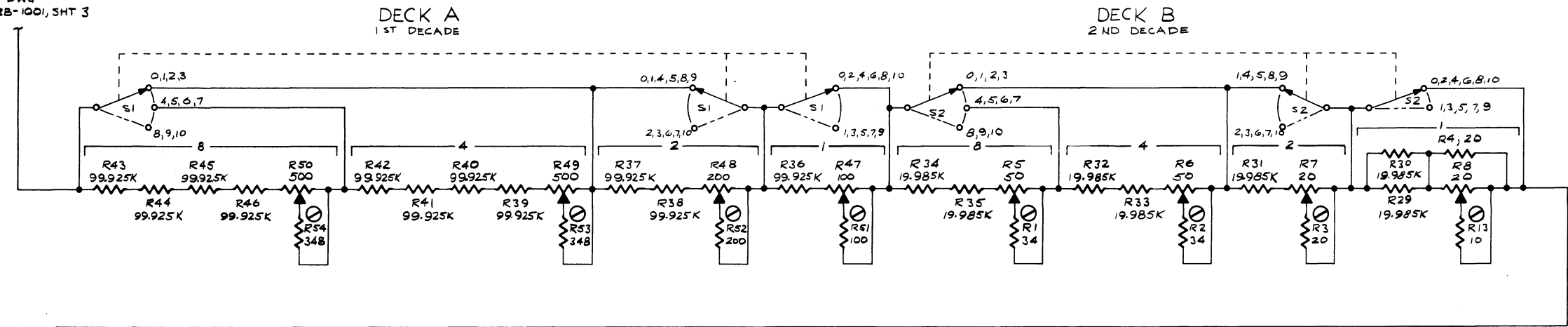

TO "b"
DWG
332B-1001, SHT 3

- NOTES:
1. RESISTANCE IN OHMS UNLESS OTHERWISE SPECIFIED.
 2. Ⓞ INTERNAL ADJUSTMENT.

FIGURE 8-3. A2 SAMPLE STRING (332B-1003)
8-8 3/75

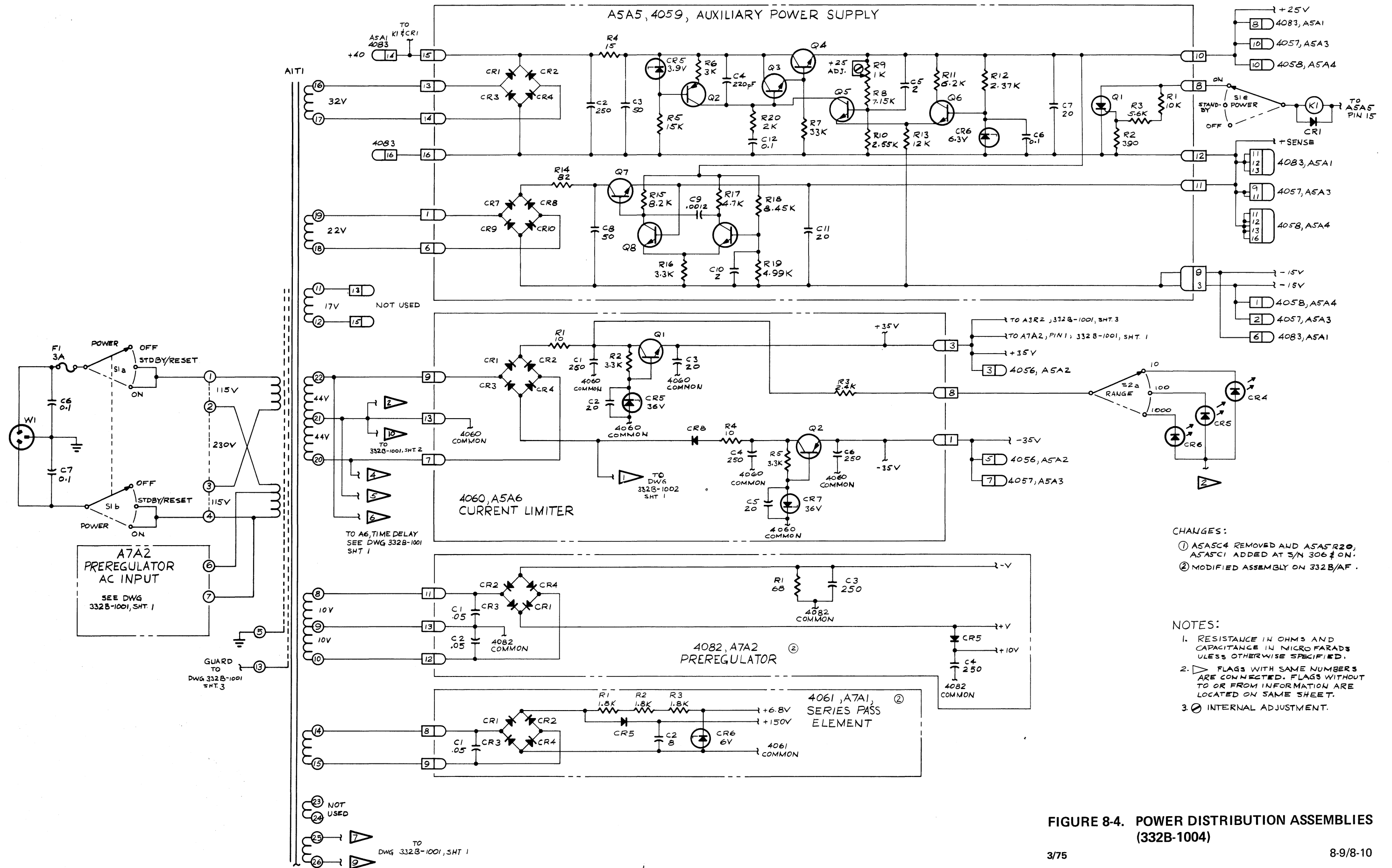

FIGURE 8-4. POWER DISTRIBUTION ASSEMBLIES (332B-1004)