

SED1330F

Graphic LCD Controller

- For Medium-scale LCD
- Simplified External Circuits
- Virtual Screen Display RAM
- Enhanced Control Function

DESCRIPTION

The SED1330F is a graphics and character display controller for use with medium scale dot matrix LCDs. The SED1330F generates all the signals required by the display memory and LCD drivers, and incorporates a character generator ROM, so that flexible, low power, display systems can be designed with a minimum number of external components.

The SED1330F's high speed MPU interface can be configured for both 6800 family and 8080 family processors, and the rich command set allows the user to create a layered display of characters and graphics, scroll the display, and assign display attributes to selected areas of the screen with a minimum of MPU intervention.

The controller also functions as a pipeline buffer between the MPU and display memory so that low cost, medium speed SRAM can be used.

The SED1330F character generator system supports user defined characters, which can be used alone, or in conjunction with the on board character set.

FEATURES

- 6800 and 8080 family compatibility, 2-pin programmable
- Programmable cursor movement
- Flexible scrolling
 - ...Scrolling in both horizontal and vertical directions
 - ...Scrolling of selected areas of the display
- Multimode display
 - ...Up to 2 layers of mixed character and graphics
 - ...Up to 3 layers of graphics
- Selectable display synthesis
 - ...Display attributes (reverse video, flashing, etc.) for selected areas of the display
 - ...Simple animation
- Supports 64K bytes of memory
 - ...4K bytes of user definable characters
 - ...60K bytes of display memory
- 160 JIS 5×7 pixel characters internal
- Supports external character ROM or RAM
 - ...8×8 or 8×16 pixel characters
 - ...Allows mixing of ROM RAM character sets
- Variable LCD duty cycle, from 1/2 to 1/256
- Low power CMOS fabrication
 - ...5mA (typical)
 - ...0.05μA (typical), standby
- Single 5V supply
- Package...SED1330F_{BA} QFP5-60pin (plastic)
SED1330F_{BB} QFP5-60pin (plastic)

BLOCK DIAGRAM

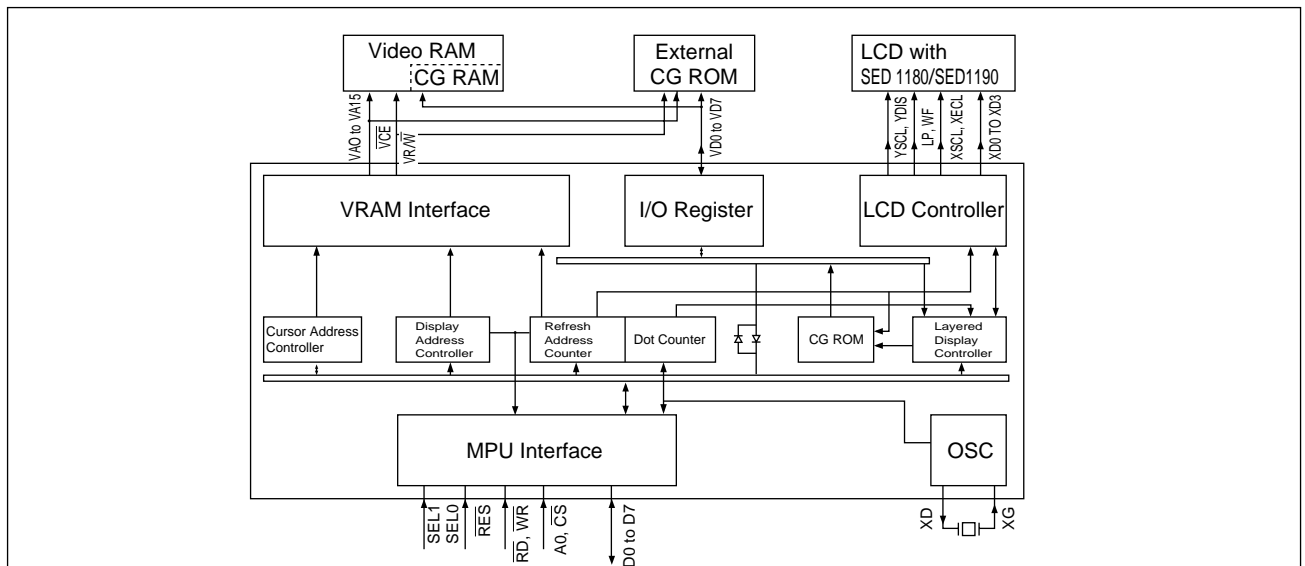

PIN CONFIGURATION

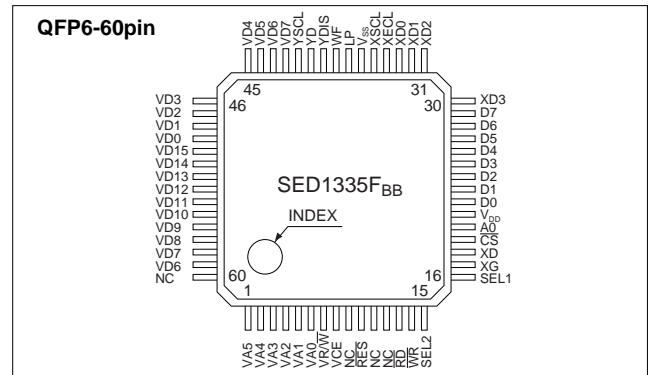
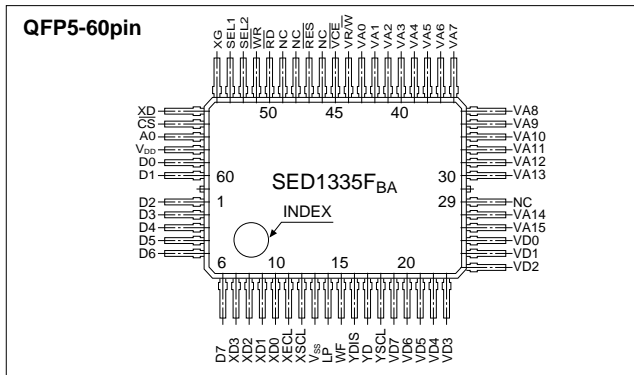

PIN DESCRIPTION

Pin Name	Pin No.		I/O	Function	Pin Name	Pin No.		I/O	Function
	SED1330F _{BA}	SED1330F _{BB}				SED1330F _{BA}	SED1330F _{BB}		
XG	54	17	I	Oscillator terminal	VD7 to VD0	19 to 26	42 to 49	I/O	VRAM data bus
XD	55	18	O	Oscillator terminal	VR/W	44	7	O	VRAM R/W signal
VDD	58	21	+5V	Power supply	VCE	45	8	O	Memory control signal
VSS	13	36	GND(0V)	Power supply	XD3 to XD0	7 to 10	30 to 33	O	Dot data output bus to X driver
SEL1,2	53•52	16•15	I	MPU interface format selection	XSCL	12	35	O	Dot data shift clock for X driver
D0 to D7	59 to 60 1 to 6	22 to 29	I/O	Data bus	LP	11	34	O	Chip enable shift clock for X driver
A0	57	20	I	Data type selection	WF	14	37	O	Dot data latch pulse
RD	50	13	I	80 series Read strobe signal 68 series "E" clock	YSCL	15	38	O	Frame signal
WR	51	14	I	80 series Write strobe signal 68 series R/ W signal	YD	18	41	O	Scan data shift clock for Y driver
CS	56	19	I	Chip select	YDIS	17	40	O	Scan data output
RES	47	10	I	Reset					
VA15 to VA0	27•28 30 to 43	1 to 6 50 to 59	O	VRAM address bus		16	39	O	Power down signal when display OFF

NC : Non Connection

ABSOLUTE MAXIMUM RATINGS

(V_{SS} = 0V)

Rating	Symbol	Value	Unit
Supply voltage	V _{DD}	-0.3 to 7.0	V
Input voltage	V _I	-0.5 to V _{DD} +0.5	V
Power dissipation	P _D	300	mW
Operating temperature	T _{opr}	-20 to 75	°C
Storage temperature	T _{stg}	-60 to 150	°C
Soldering temperature and time	T _{sol}	260°C, 10s (at lead)	—

ELECTRICAL CHARACTERISTICS

(V_{DD} = 5V±10%, V_{SS} = 0V, Ta = -20 to 75°C)

Characteristic	Symbol	Condition	Min.	Typ.	Max.	Unit
Operating voltage	V _{DD}		4.5	5.0	5.5	V
Register data retention voltage	V _{OH}		2.0	—	6.0	V
TTL	High level input voltage	V _{IHT}	2.2	—	V _{DD} +0.3	V
	Low level input voltage	V _{ILT}	-0.3	—	0.8	V
	High level output voltage	V _{OHT}	2.4	—	—	V
	Low level output voltage	V _{OLT}	—	—	0.4	V

SED1330F

Characteristic	Symbol	Condition	Min.	Typ.	Max.	Unit	
CMOS	High level input voltage	V_{IH}	$I_{OH} = 1.6\text{mA}$, $I_{OL} = -1.6\text{mA}$,	$0.8V_{DD}$	—	—	V
	Low level input voltage	V_{IL}	SEL1,2, SYNC, YD, XD0 to	—	—	$0.2V_{DD}$	V
	High level output voltage	V_{OH}	XD3, XSCL, XECL, LP, FR,	$V_{DD}-0.4$	—	—	V
	Low level output voltage	V_{OL}	YSCL, YDIS, OSC1, OSC2	—	—	0.4	V
TTL	Positive trigger threshold voltage	V_{T+}	RES*	$0.5V_{DD}$	$0.7V_{DD}$	$0.8V_{DD}$	V
	Negative trigger threshold voltage	V_{T-}		$0.2V_{DD}$	$0.3V_{DD}$	$0.5V_{DD}$	V
Input leakage current	I_{LI}	$V_I = V_{DD}$ or V_{SS}	—	0.05	2.0	μA	
Output leakage current	I_{LO}		—	0.10	5.0	μA	
Average operating current	I_{DDA}	$f_{OSC} = 10\text{MHz}$, No load (No external V-RAM)	—	8	12	mA	
Standby current	I_{DDS}	$XG = \overline{CS} = V_{DD}$	—	0.05	20	μA	
Oscillation frequency	f_{OSC}	AT X' tal XG, XD	1.0	—	10.0	MHz	
External clock frequency	f_{CLK}		—	—	10.0	MHz	
Feed back resistance	R_f		0.5	1.0	5.0	$M\Omega$	

* RES input pulse should be longer than 1.0ms.
 V_{LS} should be OFF when RES is "L"

MPU AND LCD PANEL CONNECTION EXAMPLE

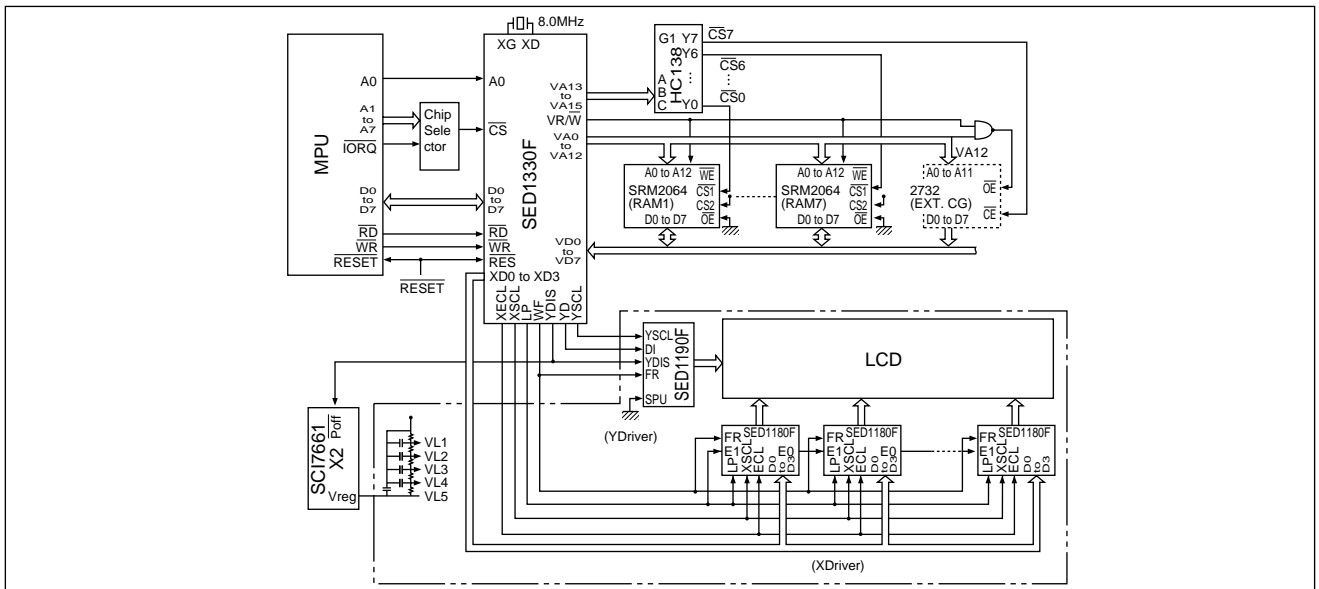

PACKAGE DIMENSIONS

● SED1330FBA

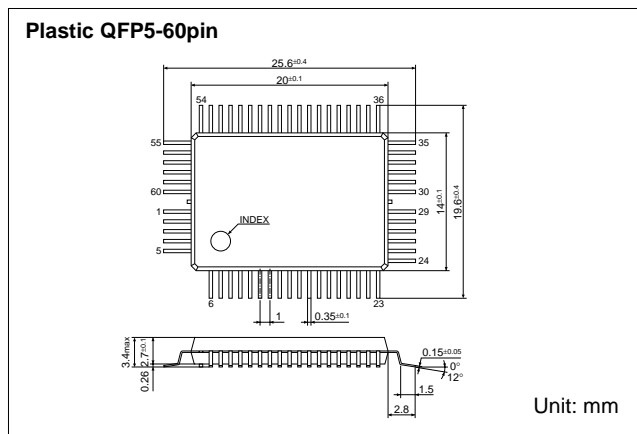

● SED1330FBB

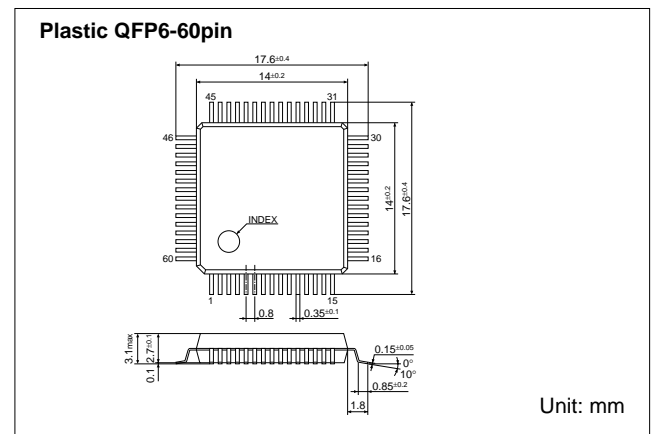

NOTICE:

No part of this material may be reproduced or duplicated in any form or by any means without the written permission of Seiko Epson. Seiko Epson reserves the right to make changes to this material without notice. Seiko Epson does not assume any liability of any kind arising out of any inaccuracies contained in this material or due to its application or use in any product or circuit and, further, there is no representation that this material is applicable to products requiring high level reliability, such as, medical products. Moreover, no license to any intellectual property rights is granted by implication or otherwise, and there is no representation or warranty that anything made in accordance with this material will be free from any patent or copyright infringement of a third party. This material or portions thereof may contain technology or the subject relating to strategic products under the control of the Foreign Exchange and Foreign Trade Control Law of Japan and may require an export license from the Ministry of International Trade and Industry or other approval from another government agency.

© Seiko Epson Corporation 1997 All right reserved.

SEIKO EPSON CORPORATION

ELECTRONIC DEVICE MARKETING DEPARTMENT

IC Marketing & Engineering Group
421-8 Hino, Hino-shi, Tokyo 191, JAPAN
Phone: 0425-87-5816 FAX: 0425-87-5624

International Marketing Department I (Europe, U.S.A.)
421-8 Hino, Hino-shi, Tokyo 191, JAPAN
Phone: 0425-87-5812 FAX: 0425-87-5564

International Marketing Department II (Asia)
421-8 Hino, Hino-shi, Tokyo 191, JAPAN
Phone: 0425-87-5814 FAX: 0425-87-5110

First issue April, 1995 
Printed January, 1997 in Japan