

# Mastering Electronics

204 MASTERING ELECTRONICS

## ISBN-10: 0333669703

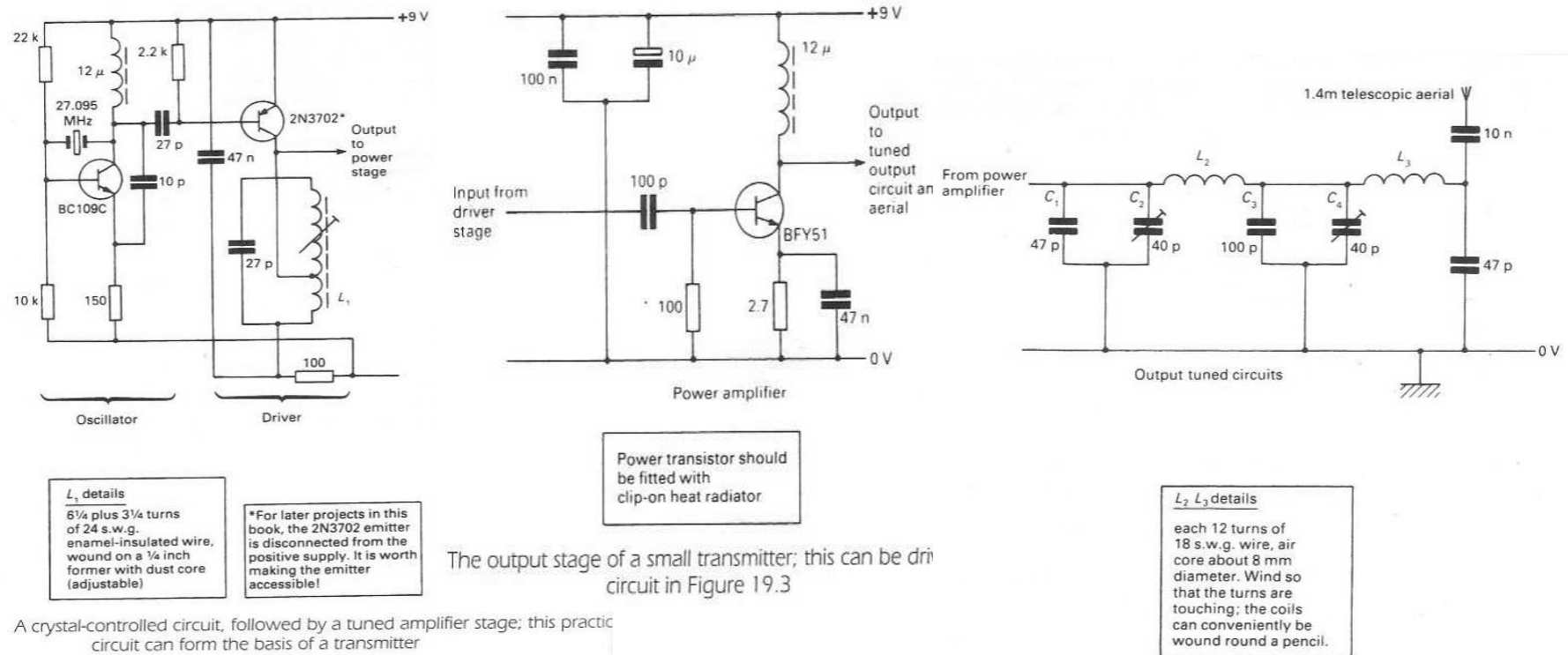

**Figure 19.3** A crystal-controlled circuit, followed by a tuned amplifier stage; this practical circuit can form the basis of a transmitter

The output stage of a small transmitter; this can be driven by the circuit in Figure 19.3

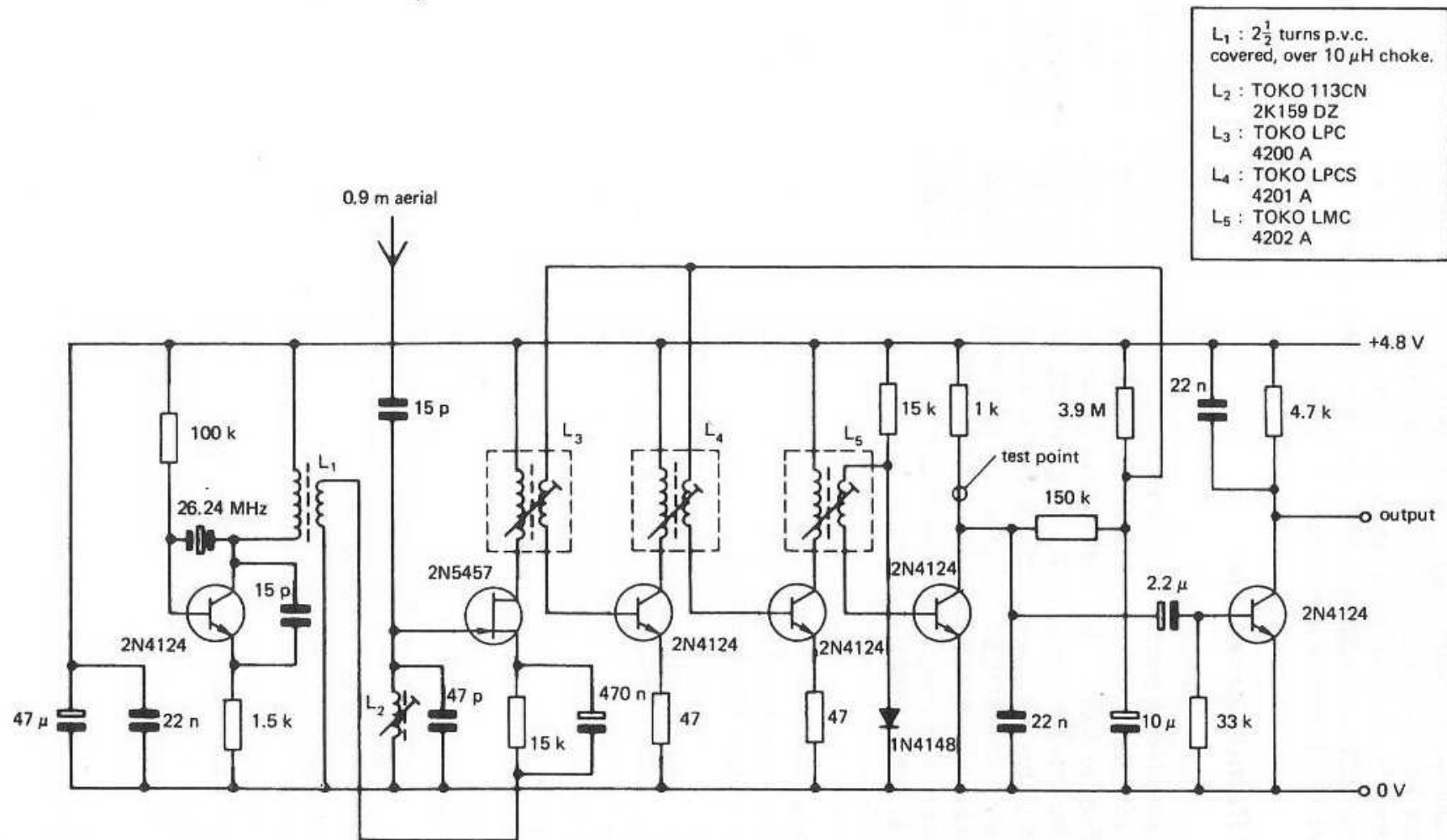

**Figure 19.22** The circuit of a complete superhet receiver; this is a practical design for use with the 27 MHz transmitter described at the beginning of the chapter. The receiver is crystal-controlled and is intended for model radio-control work. A suitable decoder circuit is given in Chapter 29. See also Appendix 1