

## Speed control using the L6235 or L6229 with a PWM output from a microcontroller

By Thomas Hopkins

Main components	
L6235, L6229	DMOS driver for three-phase brushless DC motor

### Purpose and benefits

A simple implementation of speed and direction control of a BLDC motor is described in this note. This is achieved through an alternate use of the direction control input pin of the L6235 and L6229 when a microcontroller is doing the speed regulation in voltage mode. The advantage is that this solution uses only digital inputs and outputs of the microcontroller and it does not need to generate an analog current control command and that voltage mode typically has better load response than current mode control.

The analog current control loop in the L6235 and L6229 is used for the torque limit in this example.

### Description

A simple way to interface the L6235 to a microcontroller is to connect the FWD/REV pin of the L6235 to a counter timer configured as a PWM output, as shown in figure 1.

In this configuration, the PWM controls both speed and direction. A PWM duty cycle of greater than 50% will cause the motor to run forward and a duty cycle of less than 50% will cause the motor to run in the reverse direction.

Of the three digital pins available, the FWD/REV input may not be the obvious choice for implementing the speed control, but it turns out to be a very effective choice. The BRAKE command places the output in a state with all three lower transistors turned on and is not appropriate for a speed control. One could use the enable input but you would need to have two signals from the microcontroller, the PWM for speed and the direction input. This approach is more cumbersome when crossing zero speed and reversing direction.

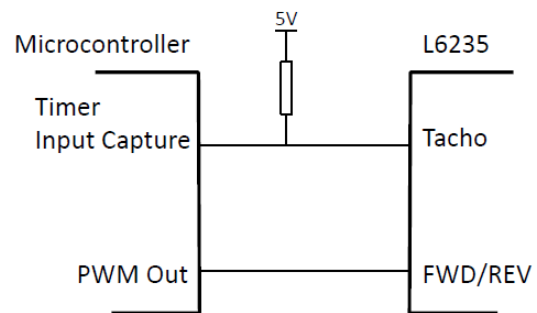

Figure 1. Connecting a L6235 to a Microcontroller

---

Analyzing the operation of the FWD/REV input, we find that it operates quite well as speed and direction input. For any fixed pattern on the hall effect inputs, the output turns on one upper and one lower transistor. If there is no change on the hall effect inputs, you are effectively working with a simple H-bridge, like driving a DC motor, and changing the FWD/REV input reverses the bridge. So in the same way that reversing the bridge in a DC motor can be used as to control a DC motor, applying the PWM to the FWD/REV input can be used for the brushless DC motor. This configuration also allows full four quadrant operation.

This configuration also allows the implementation of a position servo, if an encoder or other position sensor provides the position feedback. In this case, when the position loop is closed to hold position a full four quadrant control is achieved by simply modulating the duty cycle around the 50% point.

The maximum motor current can be limited by setting a fixed reference on the reference input for the on chip current regulator. This allows the designer to set a maximum current that effectively sets a maximum torque limit for the application, independently from the speed control loop.

For speed control, the tacho output from the L6235 can be connected to the input capture pin of a second timer channel, as shown in Figure 1, to provide the speed information (actually the period of one electrical cycle) to the microcontroller. However, this configuration provides only one update to the speed regulator every rotation (for a two pole motor). By connecting the hall effect signals to both the L6235 and the inputs to the microcontroller as shown in Figure 2, and looking at both the rising and falling edge of the three signals, you can get 6 updates every rotation. The increased feedback can be very important for low speed applications. Some microcontrollers, like the STM32, have timer channels that can be configured to do the exclusive OR of the three signals to automatically get a signal for all six edges.

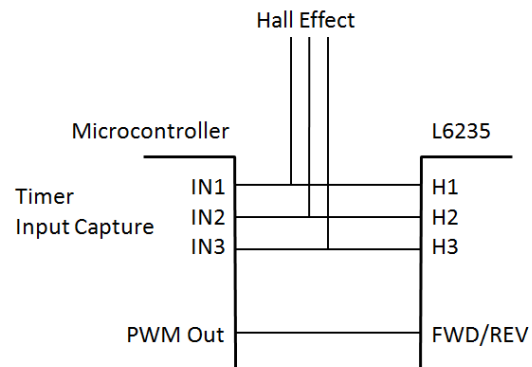

Figure 2: Improved speed feedback

---

## Support material

Related design support material
Product/ System evaluation boards EVAL6235N, three-phase brushless DC motor driver demonstration board EVAL6235PD, three-phase brushless DC motor driver demonstration board
Documentation
Datasheets L6235, DMOS driver for three-phase brushless DC motor L6229, DMOS driver for three-phase brushless DC motor
Data Brief: EVAL6235PD: L6235 three-phase brushless DC motor driver demonstration board
Application Notes: AN1625: L6235 three phase brushless DC motor driver AN3134: EVAL6229QR demonstration board using the L6229Q DMOS driver for a three-phase BLDC motor control application
Schematics: EVAL6235N schematic EVAL6235PD schematic EVAL6229PD schematic

## Revision history

Date	Version	Changes
01 Apr 2012	1	Initial release

---

### Please Read Carefully

Information in this document is provided solely in connection with ST products. STMicroelectronics NV and its subsidiaries ("ST") reserve the right to make changes, corrections, modifications or improvements, to this document, and the products and services described herein at anytime, without notice.

All ST products are sold pursuant to ST's terms and conditions of sale.

Purchasers are solely responsible for the choice, selection and use of the ST products and services described herein, and ST assumes no liability whatsoever relating to the choice, selection or use of the ST products and services described herein.

No license, express or implied, by estoppel or otherwise, to any intellectual property rights is granted under this document. If any part of this document refers to any third party products or services it shall not be deemed a license grant by ST for the use of such third party products or services, or any intellectual property contained therein or considered as a warranty covering the use in any manner whatsoever of such third party products or services or any intellectual property contained therein.

**UNLESS OTHERWISE SET FORTH IN ST'S TERMS AND CONDITIONS OF SALE ST DISCLAIMS ANY EXPRESS OR IMPLIED WARRANTY WITH RESPECT TO THE USE AND/OR SALE OF ST PRODUCTS INCLUDING WITHOUT LIMITATION IMPLIED WARRANTIES OF MERCHANTABILITY, FITNESS FOR A PARTICULAR PURPOSE (AND THEIR EQUIVALENTS UNDER THE LAWS OF ANY JURISDICTION), OR INFRINGEMENT OF ANY PATENT, COPYRIGHT OR OTHER INTELLECTUAL PROPERTY RIGHT.**

**UNLESS EXPRESSLY APPROVED IN WRITING BY TWO AUTHORIZED ST REPRESENTATIVES, ST PRODUCTS ARE NOT RECOMMENDED, AUTHORIZED OR WARRANTED FOR USE IN MILITARY, AIR CRAFT, SPACE, LIFE SAVING, OR LIFE SUSTAINING APPLICATIONS, NOR IN PRODUCTS OR SYSTEMS WHERE FAILURE OR MALFUNCTION MAY RESULT IN PERSONAL INJURY, DEATH, OR SEVERE PROPERTY OR ENVIRONMENTAL DAMAGE. ST PRODUCTS WHICH ARE NOT SPECIFIED AS "AUTOMOTIVE GRADE" MAY ONLY BE USED IN AUTOMOTIVE APPLICATIONS AT USER'S OWN RISK.**

Resale of ST products with provisions different from the statements and/or technical features set forth in this document shall immediately void any warranty granted by ST for the ST product or service described herein and shall not create or extend in any manner whatsoever, any liability of ST.

ST and the ST logo are trademarks or registered trademarks of ST in various countries.

Information in this document supersedes and replaces all information previously supplied.

The ST logo is a registered trademark of STMicroelectronics. All other names are the property of their respective owners.

© 2012 STMicroelectronics - All rights reserved

STMicroelectronics group of companies

Australia - Belgium - Brazil - Canada - China - Czech Republic - Finland - France - Germany - Hong Kong - India - Israel - Italy - Japan - Malaysia - Malta - Morocco - Philippines - Singapore - Spain - Sweden - Switzerland - United Kingdom - United States of America

[www.st.com](http://www.st.com)