

# SoftBaugh

4080 McGinnis Ferry Road  
Suite 604  
Alpharetta, GA 30005  
www.softbaugh.com

## SBLCDA2/T

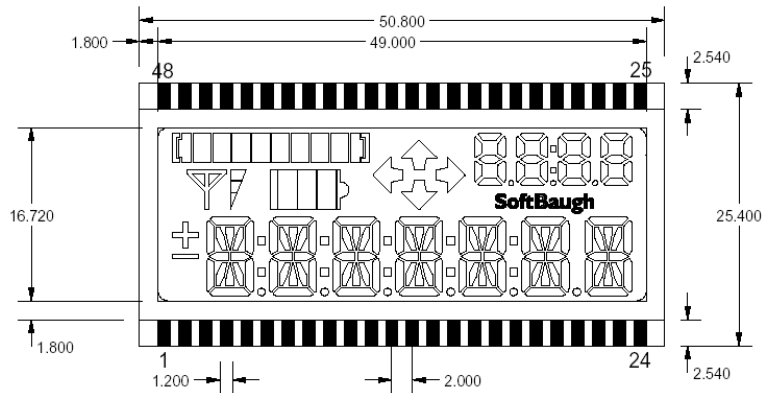

### Overview:

Our advanced SBLCDA2 and SBLCDA2T are compatible with all MSP430F44x devices. The SBLCDA2 is for daytime use only while the SBLCDA2T is transfective, which allows a backlight to be installed for optional nighttime use. These two LCDs offer the following:

- 2.7v to 3.6v operation directly connected to the MSP430 LCD drive
- 4-mux operation
- Seven 14-segment digits with plus/minus symbology allows versatile text
- Supplemental 4-digit 7-segment clock-counter display
- Arrows left, up, right, and down
- Battery with 3-segment meter
- Antenna with 3-segment meter
- Colons for HH:MM:SS operation
- Progress bar for convenient user feedback
- 6 o'clock viewing angle
- Low-cost bias circuit allows adjustment for viewing angle, contrast, and temperature
- Transfective option allows for the addition of a backlight for nighttime viewing (SBLCDA2T only)
- Operating temperature  $-20^{\circ}\text{C}/50^{\circ}\text{C}$

### Typical Operation:

The following graphs illustrate the SBLCDA2 and SBLCDA2Ts viewing angles for the range of  $V_{CC}$  from 2.7v to 3.6v. The voltage was measured on pin 56 (R03) of the MSP430F449. This is the input port of the lowest analog LCD level (V5). The voltage is controlled by P2 on our ES449 development kit and can be measured at TP27.

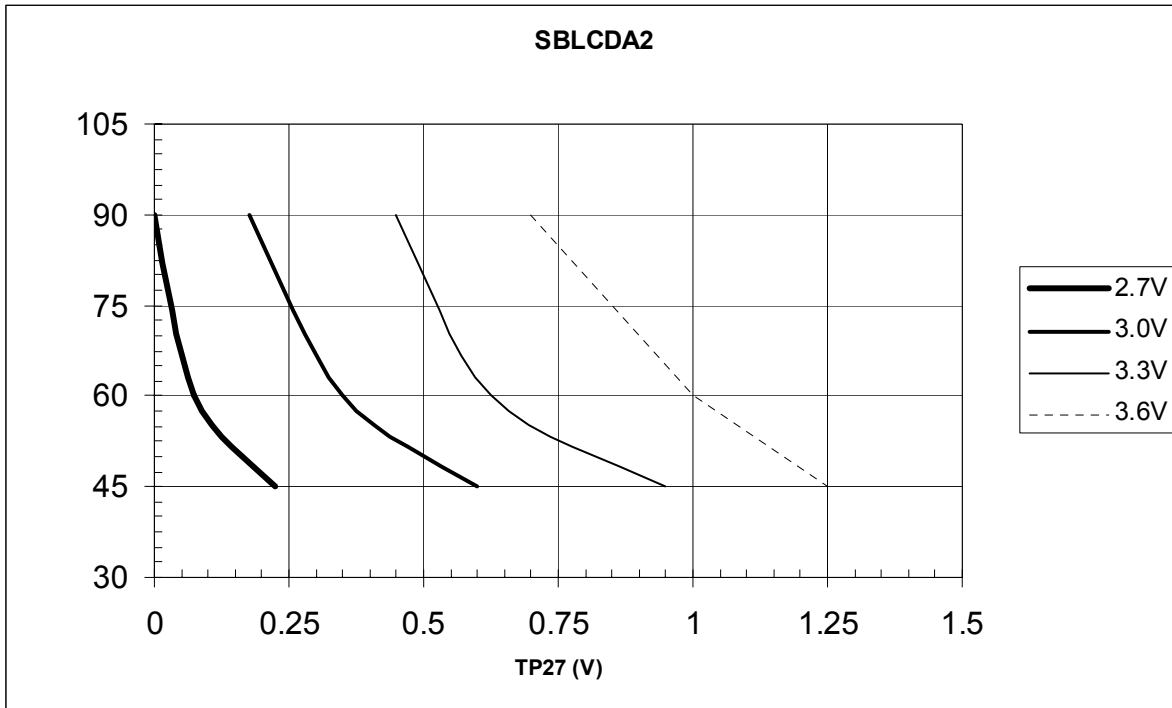

Figure 1.

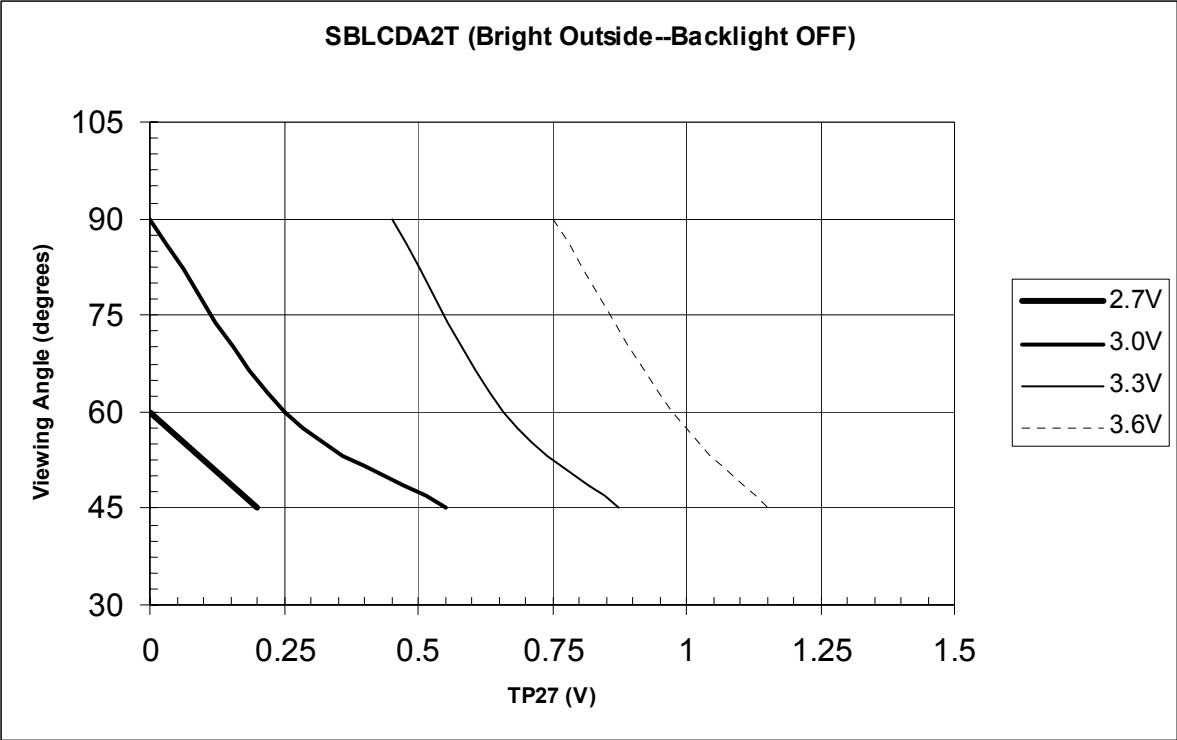

Figure 2.

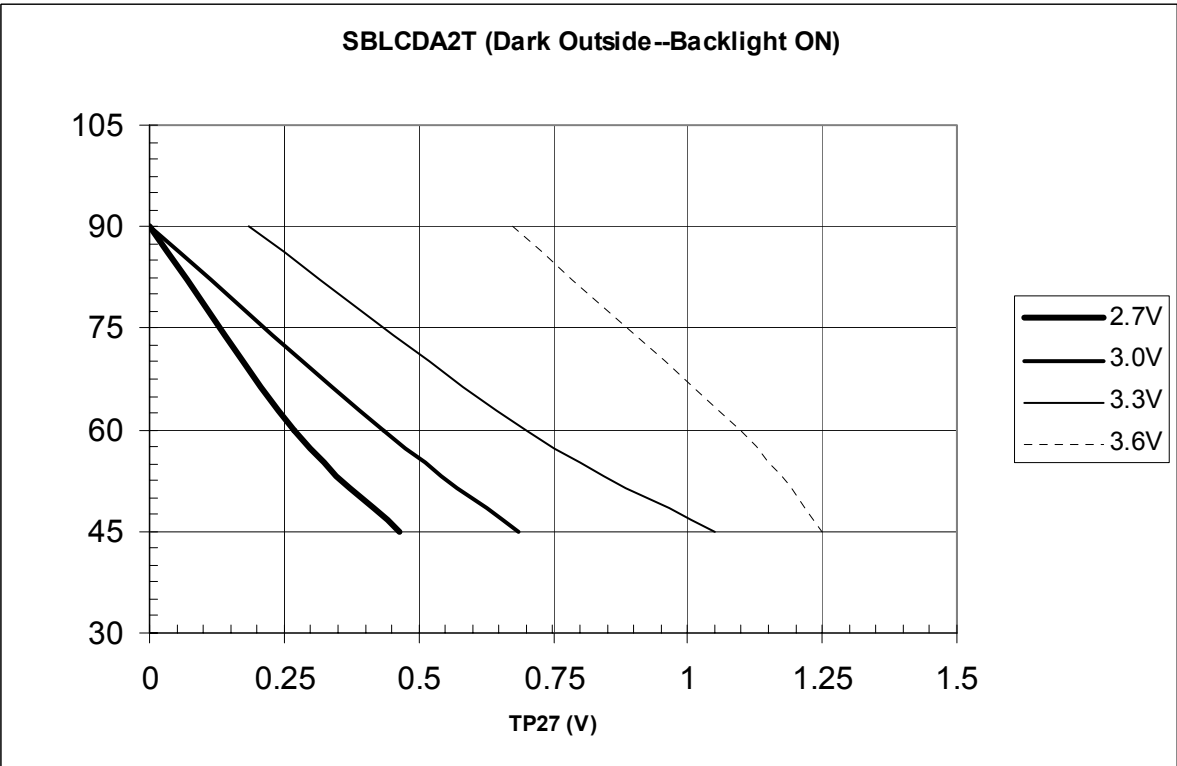
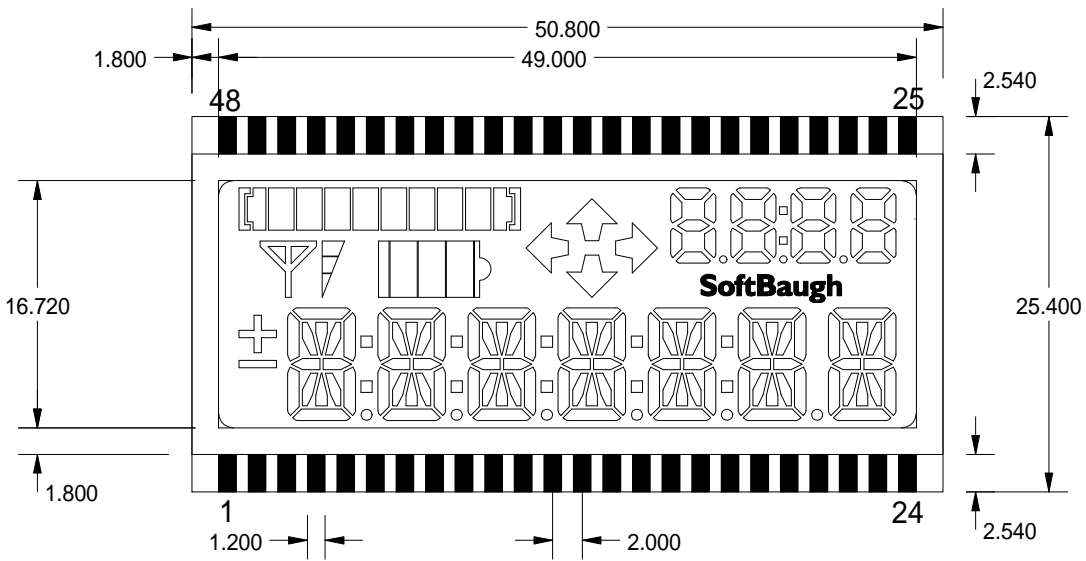

Figure 3.



# SBLCDA2

Rev 1.1.0, 15 July 2002

SoftBaugh, Inc.  
 5040 Oakmont Bend Drive  
 Alpharetta, GA 30004 USA  
[www.softbaugh.com](http://www.softbaugh.com)  
 (770) 772-8111  
 (770) 772-9030 (fax)

Pins both sides, 2.0mm pitch, .5mm wide at PCB, 6.5mm long overall

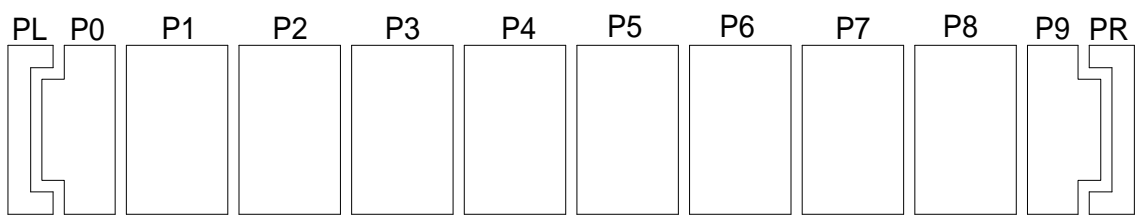
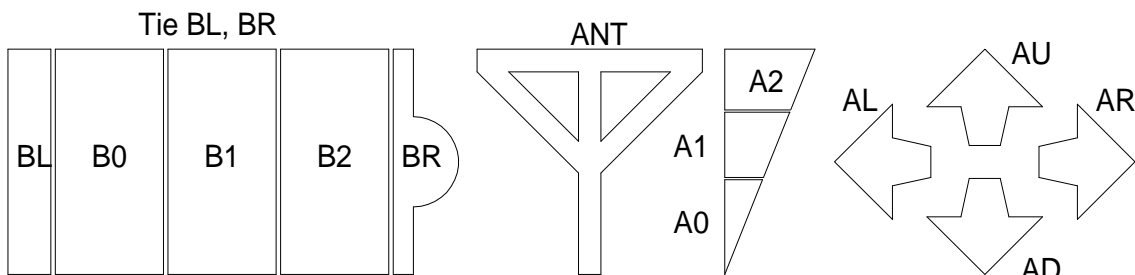
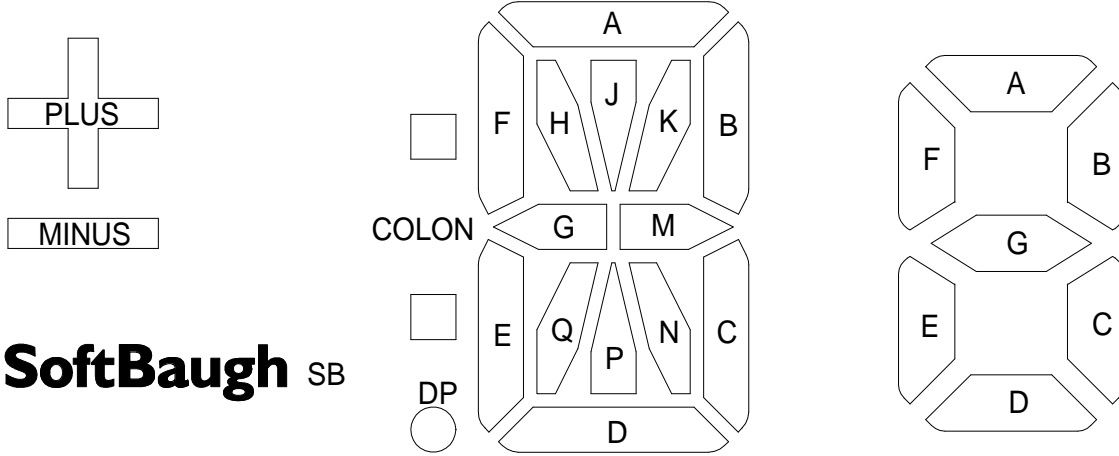
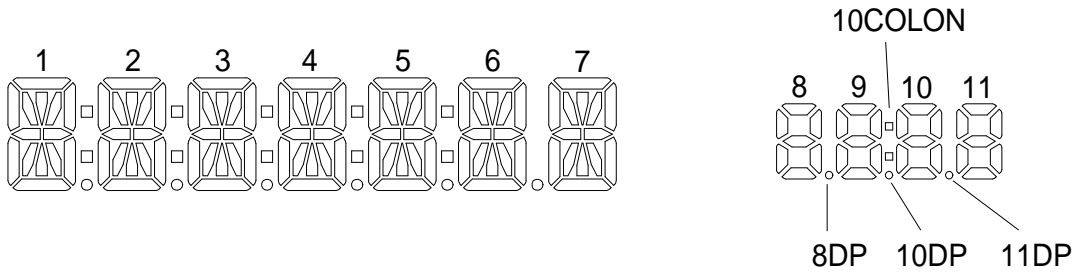

### SBLCDA2 Segment Mapping

PIN	COM3	COM2	COM1	COM0		COM3	COM2	COM1	COM0	PIN
1	1A	1B	1C	1D		COM3				48
2	1J	1K	1M	1N			COM2			47
3	2COL	2F	2E	1DP				COM1		46
4	2H	2G	2Q	2P					COM0	45
5	2A	2B	2C	2D		1H	1G	1Q	1P	44
6	2J	2K	2M	2N		PLUS	1F	1E	MINUS	43
7	3COL	3F	3E	2DP		A1	A2	ANT	A0	42
8	3H	3G	3Q	3P		PL	P0	P1	P2	41
9	3A	3B	3C	3D		P6	P5	P4	P3	40
10	3J	3K	3M	3N		NC	NC	NC	NC	39
11	4COL	4F	4E	3DP		NC	NC	NC	NC	38
12	4H	4G	4Q	4P		P7	P8	P9	PR	37
13	4A	4B	4C	4D		B0	B1	B2	BRBL	36
14	4J	4K	4M	4N		AD	AR	AU	AL	35
15	5COL	5F	5E	4DP		8D	8E	8G	8F	34
16	5H	5G	5Q	5P		8DP	8C	8B	8A	33
17	5A	5B	5C	5D		9D	9E	9G	9F	32
18	5J	5K	5M	5N		10DP	9C	9B	9A	31
19	6COL	6F	6E	5DP		10COL	10E	10F	10A	30
20	6H	6G	6Q	6P		10D	10C	10G	10B	29
21	6A	6B	6C	6D		11DP	11E	11F	11A	28
22	6J	6K	6M	6N		11D	11C	11G	11B	27
23	SB	7F	7E	6DP		7J	7K	7M	7N	26
24	7H	7G	7Q	7P		7A	7B	7C	7D	25

### Recommended SBLCDA2 Footprint

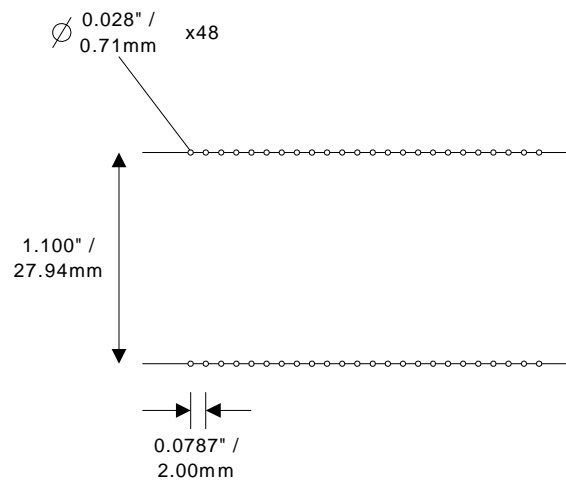

# SBLCA2 Circuit Examples

## Sample MSP430F449 Interconnect

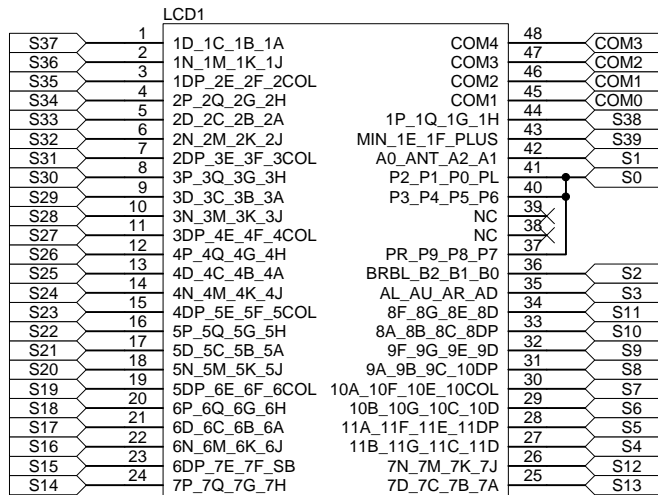

General design principle is to choose three segment lines (twelve segment features) to be unused, and tie them together. Then, ensure that segment line is perpetually disabled.

In this example, the progress bar is disabled.

## Sample MSP430 Bias Circuit

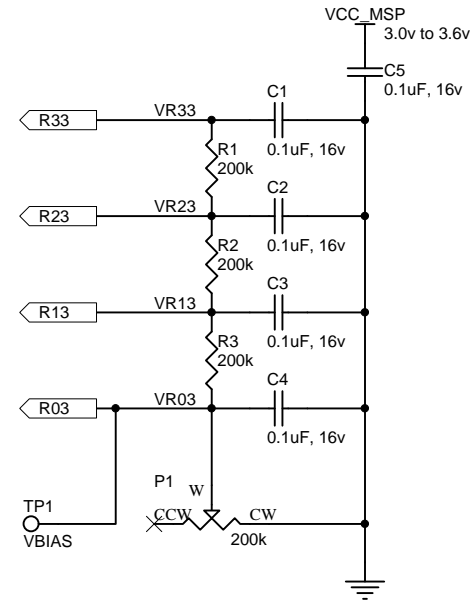

By manipulating the R03 voltage, the contrast and viewing angle can be adjusted for a wide variety of operating voltages and temperatures.

**SoftBaugh**

www.softbaugh.com 800 794-5756  
 Sheet: SBLCA2  
 Project: Sample MSP430 Interconnect  
 Date: 3-Jan-2003 1 of 1 v. 1