

## PRODUKTINFORMATION



**HÄMTFAX**  
08-580 941 14



**FAX ON DEMAND**  
+46 8 580 941 14



**INTERNET**  
<http://www.elfa.se>

TEKNISK INFORMATION 020-75 80 20    ORDERTEL 020-75 80 00    ORDERFAX 020-75 80 10

TECHNICAL INFORMATION +46 8 580 941 15    ORDERPHONE +46 8 580 941 01    ORDERFAX +46 8 580 941 11

— Vi reserverar oss mot fel samt förbehåller oss rätten till ändringar utan föregående meddelande —

ELFA artikelnr.  
73-104-85 UV1316/IEC TV-tuner

Antal sidor: 20

# DATA SHEET

## **UV1316** VHF/UHF television tuner

Preliminary specification  
File under BU Tuners, DC03

1996 Oct 10

**VHF/UHF television tuner****UV1316****FEATURES**

- Member of the UV1300 family small sized UHF/VHF tuners
- Systems CCIR: B/G, H, L, L', I and I'; OIRT: D/K
- Digitally controlled (PLL) tuning via I<sup>2</sup>C-bus
- Off-air channels, S-cable channels and Hyperband
- Globally standardized mechanical dimensions and global standard pinning
- Compact size
- Complies to "CENELEC EN55020" and "EN55013".

**DESCRIPTION**

The UV1316 tuner belongs to the UV1300 family of tuners, which are designed to meet a wide range of applications. It is a combined VHF, UHF tuner suitable for CCIR systems B/G, H, L, L', I and I'. The low IF output impedance has been designed for direct drive of a wide variety of saw filters with sufficient suppression of triple transient.

The tuners comply with the requirements of radiation, signal handling capability and immunity conforming with:

- CISPR 13 (1990) incl. amendment 1 (1992) and amendment 2 (1993)
- European standards CENELEC EN55013, EN55020.

**MARKING**

The following items of information are printed on a sticker that is on the top cover of the tuner:

- Type number
- Code number
- Origin letter of factory
- Change code
- Year and week code.

**ORDERING INFORMATION**

TYPE	DESCRIPTION	ORDER NUMBERS
UV1316/I	IEC; symmetrical IF output	3139 147 13171
UV1316AS/I	IEC; asymmetrical IF output	3139 147 13191
UV1316/PH	standard phono; symmetrical IF output	3139 147 13161
UV1316AS/PH	standard phono; asymmetrical IF output	3139 147 13181

## VHF/UHF television tuner

UV1316

## INTERMEDIATE FREQUENCIES

SIGNAL	FREQUENCY <sup>(1)</sup> (MHz)					
	SYSTEM B/G, H	SYSTEM L	SYSTEM L'	SYSTEM D/K	SYSTEM I	SYSTEM I'
Picture carrier	38.90	38.90	33.40	38.90	39.50	38.90
Colour	34.47	34.47	37.83	34.62	35.07	34.47
Sound 1	33.40	32.40	39.90	32.40	33.50	32.90
Sound 2 (if applicable)	33.16	–	–	–	33.00	32.40

**Note**

1. The oscillator frequency is above the input signal frequency.

## CHANNEL COVERAGE

BAND	OFF-AIR CHANNELS		CABLE CHANNELS	
	CHANNELS	FREQUENCY RANGE (MHz)	CHANNELS	FREQUENCY RANGE (MHz)
Low band	E2 to C	48.25 to 82.25 <sup>(1)</sup>	S01 to S10	69.25 to 168.25
Mid band	E5 to E12	175.25 to 224.25	S11 to S39	231.25 to 447.25
High band	E21 to E69	471.25 to 855.25 <sup>(2)</sup>	S40 to S41	455.25 to 463.25

**Notes**

1. Enough margin is available to tune down to 45.25 MHz.
2. Enough margin is available to tune up to 863.25 MHz.

VHF/UHF television tuner

UV1316

BLOCK DIAGRAM

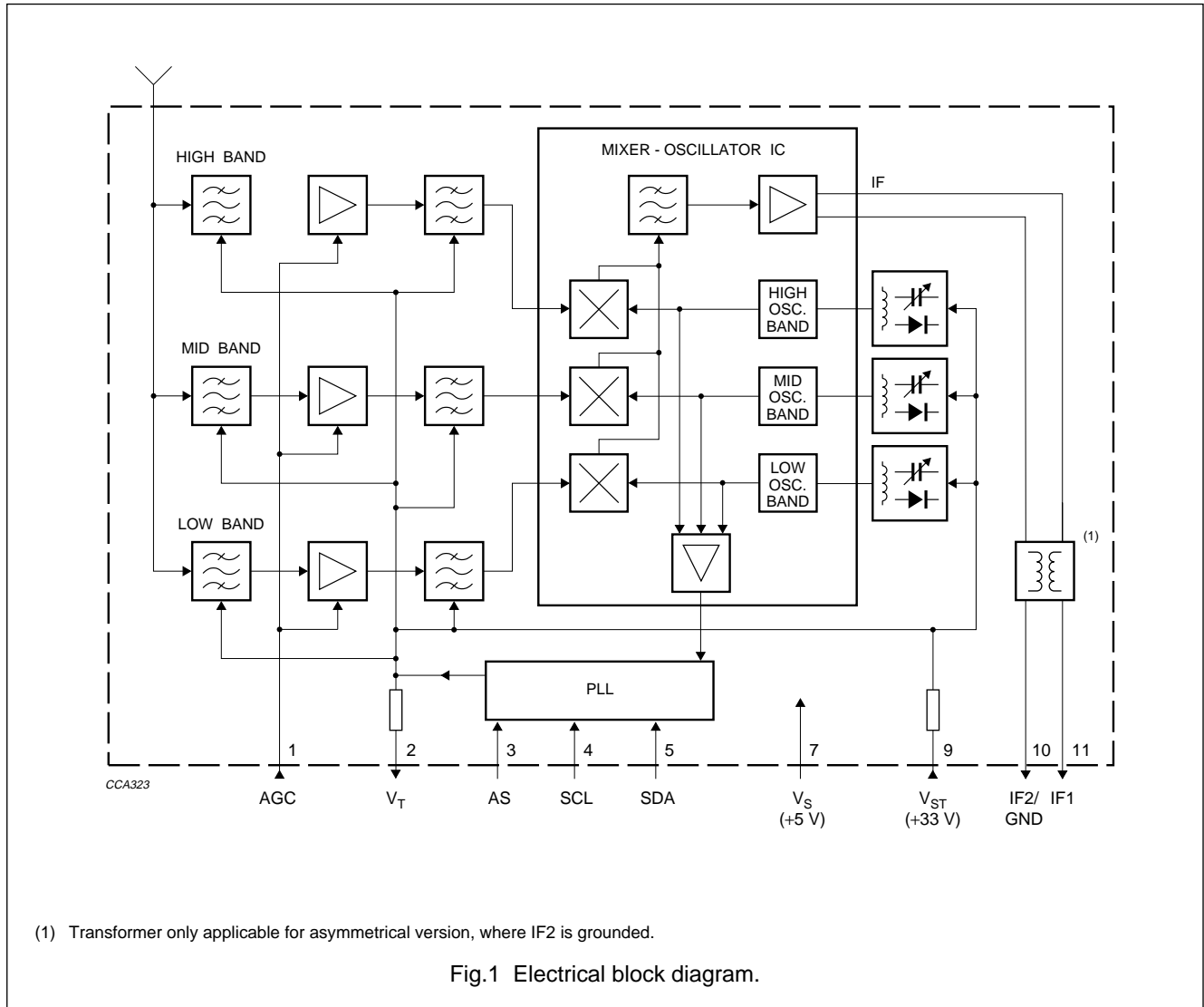

(1) Transformer only applicable for asymmetrical version, where IF2 is grounded.

## VHF/UHF television tuner

UV1316

**PINNING**

SYMBOL	PIN	DESCRIPTION
AGC	1	gain control voltage
V <sub>T</sub>	2	tuning voltage
AS	3	I <sup>2</sup> C-bus address select
SCL	4	I <sup>2</sup> C-bus serial clock
SDA	5	I <sup>2</sup> C-bus serial data
n.c.	6	not connected
V <sub>S</sub>	7	PLL supply voltage +5 V
n.c.	8	not connected
V <sub>ST</sub>	9	tuner supply voltage +33 V
IF2/GND	10	UV1316: symmetrical IF output; UV1316AS: ground
IF1	11	UV1316: symmetrical IF output; UV1316AS: asymmetrical IF output
GND	TH1, TH2, TH3 and TH4	mounting tags (ground)

**LIMITING VALUES****Environmental conditions**

SYMBOL	PARAMETER	CONDITIONS	MIN.	TYP.	MAX.	UNIT
<b>Non-operational conditions</b>						
T <sub>amb</sub>	ambient temperature		-25	-	+85	°C
RH	relative humidity		-	-	100	%
g <sub>B</sub>	bump acceleration	25 g	-	-	245	m/s <sup>2</sup>
g <sub>S</sub>	shock acceleration	50 g	-	-	490	m/s <sup>2</sup>
	vibration amplitude	10 to 55 Hz	-	0.35	-	mm
<b>Operational conditions</b>						
T <sub>amb</sub>	ambient temperature		-10	-	+60	°C
RH	relative humidity		-	-	95	%

## VHF/UHF television tuner

UV1316

**Limiting values under operational conditions**

The tuner can be guaranteed to function properly under the following conditions.

SYMBOL	PARAMETER	PIN	MIN.	TYP.	MAX.	UNIT
V <sub>S</sub>	supply voltage	7	4.75	5.00	5.50	V
V <sub>S(ripple)</sub>	peak-to-peak ripple voltage susceptibility; note 1		–	–	28.5	mV
I <sub>S</sub>	supply current		–	–	130	mA
V <sub>ST</sub>	supply voltage	9	30	33	35	V
V <sub>ST(ripple)</sub>	peak-to-peak ripple voltage susceptibility		–	–	10	mV
I <sub>ST</sub>	supply current		–	–	1.7	mA
V <sub>AGC</sub>	AGC input voltage	1	–	4.0	4.5	V
ΔV <sub>AGC</sub>	AGC input voltage range		0.3	–	4.0	V
I <sub>AGC</sub>	AGC input current		–	–	20	μA
V <sub>AS</sub>	address select input voltage	3	–	–	5.5	V
V <sub>SCL</sub>	serial clock input voltage	4	–0.3	–	5.5	V
V <sub>SDA</sub>	serial data input voltage	5	–0.3	–	5.5	V
I <sub>SDA</sub>	serial data input current		–1	–	5	mA

**Note**

1. Sinusoidal ripple voltage superimposed on the 5 V supply voltage in the frequency range of 20 Hz to 500 kHz.  
Criteria for TV interference >57 dB.

**ELECTRICAL DATA****Conditional data**

Unless otherwise specified, all electrical values for Chapter “Electrical data” apply at the following conditions and the electrical performance is related to system B,G and H.

A proper function is guaranteed within the specified operational conditions but a certain deterioration of performance parameters may occur at the limits of the operational conditions.

SYMBOL	PARAMETER	VALUE	UNIT
T <sub>amb</sub>	ambient temperature	25 ±5	°C
RH	relative humidity	60 ±15	%
V <sub>S</sub>	supply voltage	5.0 ±0.125	V
V <sub>AGC</sub>	AGC input voltage	4.0 ±0.1	V
V <sub>ST</sub>	tuning voltage	33 ±0.5	V
t <sub>pr</sub>	pre-heating time (+5 V at pin 7)	10	minute
Z <sub>S(AE)</sub>	aerial source impedance (unbalanced)	75	Ω

## VHF/UHF television tuner

UV1316

## Aerial input characteristics

SYMBOL	PARAMETER	CONDITIONS	MIN.	MAX.	UNIT
V <sub>SWR</sub>	reflection coefficient	referred to 75 $\Omega$ impedance (worst case on or between picture and sound carrier at maximum gain)	–	5	
V <sub>PSM</sub>	surge protection voltage		5	–	kV
V <sub>ant</sub>	antenna connection disturbance voltage	<1.75 GHz; complies to "EN55013 section 3.3"	–	46	dB $\mu$ V

## General characteristics

SYMBOL	PARAMETER	CONDITIONS	MIN.	TYP.	MAX.	UNIT
f <sub>b</sub>	frequency range: low band mid band high band		48.25 170.0 450.0	– – –	170.0 450.0 855.2	MHz MHz MHz
$\Delta$ f <sub>b</sub>	margin: for low band for mid/high band		$\pm$ 1 $\pm$ 3	– –	– –	MHz MHz
G <sub>V</sub>	voltage gain: all channels gain taper (off-air channels)		38 –	44 –	50 8	dB dB
	noise: low band mid band high band		– – –	6 6 6	9 9 9	dB dB dB
$\Delta$ V <sub>AGC</sub>	AGC input voltage range: VHF off-air channels cable channels high band		40 35 30	65 60 50	– – –	dB dB dB
$\alpha$ <sub>i</sub>	image rejection (nominal gain to 10 dB gain reduction): low and mid band mid band high band	<300 MHz >300 MHz	70 60 50	75 75 75	– – –	dB dB dB
$\alpha$ <sub>IF</sub>	IF rejection (picture)		60	80	–	dB
Z <sub>IF</sub>	$\frac{1}{2}$ IF susceptibility: channel E2 to E12 channel E21 to E69		75 60	90 80	– –	dB $\mu$ V dB $\mu$ V

## VHF/UHF television tuner

## UV1316

SYMBOL	PARAMETER	CONDITIONS	MIN.	TYP.	MAX.	UNIT
$\alpha_S$	sound-chrominance moiré rejection: off-air	up to 40 dB gain reduction	56	65	–	dB
	UHF	up to 30 dB minimum gain reduction	56	75	–	dB
	breakthrough susceptibility		60	–	–	dB $\mu$ V
$m_x$	cross modulation: in-channel		68	–	–	dB $\mu$ V
	in-band					
	low band (n $\pm$ 2)		80	–	–	dB $\mu$ V
	mid band (n $\pm$ 3)		80	–	–	dB $\mu$ V
	high band (n $\pm$ 5)		84	–	–	dB $\mu$ V
	out of band		–	100	–	dB $\mu$ V
$V_{osc}$	oscillator voltage: IF pin		–	–	85	dB $\mu$ V
	all other pins		–	–	70	dB $\mu$ V
	overloading: 1 dB gain compression		74	81	–	dB
	detuning of oscillator at +300 to –1000 kHz		80	100	–	dB
	PLL lock-out		90	–	–	dB
	pulling	10 kHz	68	–	–	dB
	tuning system interference: crystal harmonics interference rejection at IF output		54	–	–	dB
	divider interference rejection at IF output	input level 50 dB $\mu$ V	57	–	–	dB
	residual carrier FM caused by I <sup>2</sup> C-bus cross-talk		–	–	5	kHz
$V_{ESD}$	electrostatic discharge (ESD) on all pins	note 1	2	–	–	kV
	oscillator characteristics: oscillator tuning resolution		–	–	$\pm$ 250	kHz
	oscillator instability	$V_S = 5\text{ V} \pm 10\%$ ; $T_{amb} = 0\text{ to }60\text{ }^\circ\text{C}$	–	–	$\pm$ 500	kHz
	lock-in time		–	–	150	msec

**Note**

1. All the pins of the tuner are protected against electrostatic discharge (ESD) up to 2 kV. The product is classified in category B ("MIL-STD-883C").

## VHF/UHF television tuner

UV1316

## AMPLITUDE RESPONSE

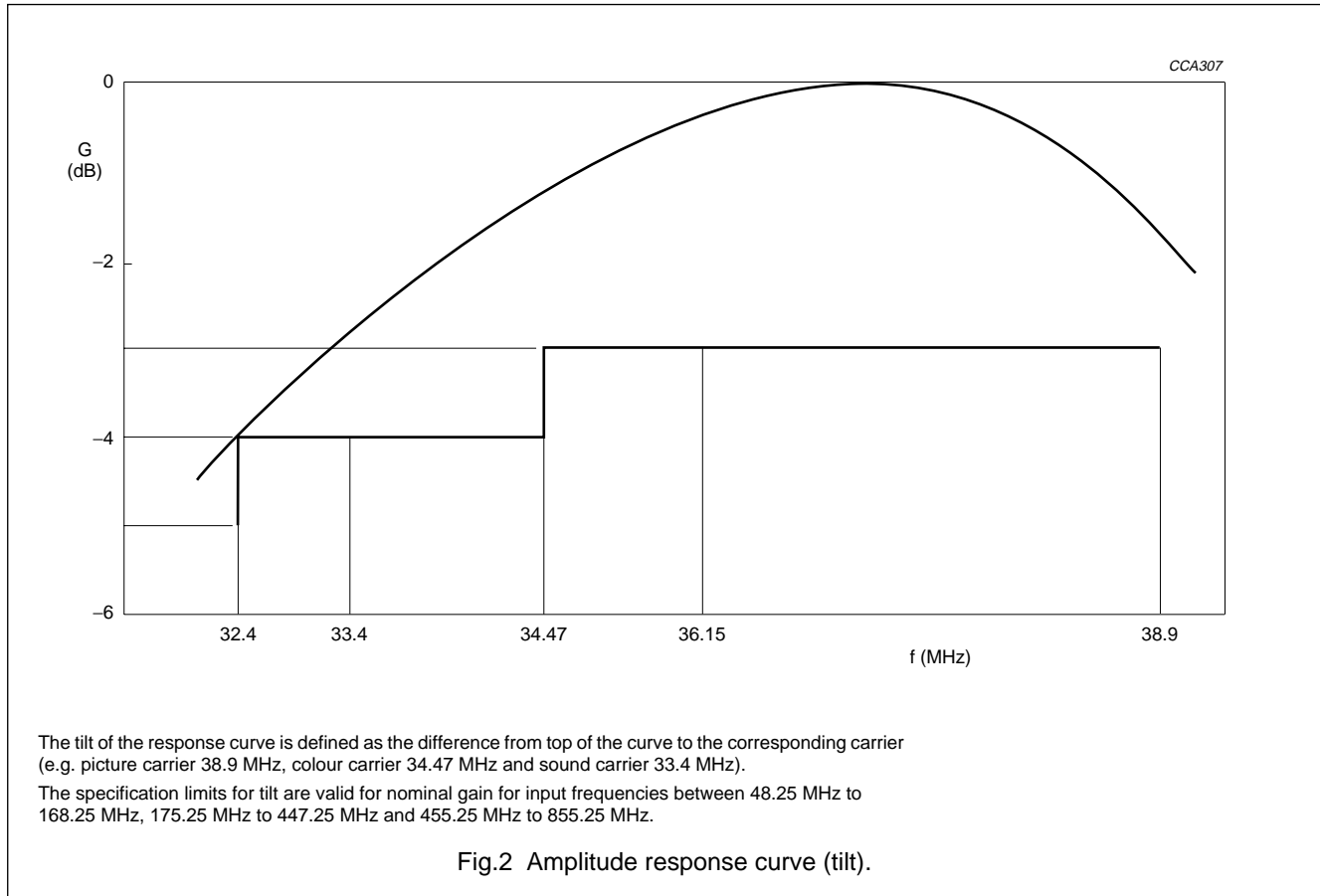
**Visibility test (input immunity and immunity from radiated fields)**

The tuners meet the requirements of the european norm "EN55020", when measured in an adequate television receiver. The AGC must be adjusted such that the picture carrier level (top sync.) at the tuner output does not exceed 105 dB $\mu$ V at an input signal level of 74 dB $\mu$ V or greater.

**Radiation**

The tuners meet the requirements of the european norm "EN55013" and "CISPR13" (1990), when measured in an adequate television receiver.

**Microphony**

For sound signals in the audio frequency range 100 Hz to 10 kHz and sound pressure levels up to 105 dB (20  $\mu$ Pa), the video signal to sound interference ratio will be greater than 40 dB.

## VHF/UHF television tuner

## UV1316

## APPLICATION INFORMATION

A detailed description of the I<sup>2</sup>C-bus specification, with applications, is given in brochure "The I<sup>2</sup>C-bus and how to use it." This brochure may be ordered using the code number 9398 393 40011.

## WRITE mode

BYTE	BITS								
	7 MSB	6	5	4	3	2	1	0 LSB	A <sup>(1)</sup>
Address byte	1	1	0	0	0	MA1	MA0	R/W <sup>(2)</sup>	A
Program divider byte 1	0	n14	n13	n12	n11	n10	n9	n8	A
Program divider byte 2	n7	n6	n5	n4	n3	n2	n1	n0	A
Control information byte 1	1	CP	0	0	1	1	1	0	A
Control information byte 2	P7	P6	P5	P4	P3	P2	P1	P0	A

## Notes

1. A = Acknowledge.
2. R/W bit = 0 for WRITE mode, R/W bit = 1 for READ mode.

## ADDRESS SELECTION

V<sub>S</sub> = +5 V (PLL supply voltage); for all UV1316 tuner types, the AS input (pin 3) is left floating.

MA1	MA0	ADDRESS	VOLTAGE AT PIN 3
0	0	C0	0 to 0.1V <sub>S</sub>
0	1	C2	don't care (see notes 1 and 2)
1	0	C4	0.4 to 0.6V <sub>S</sub>
1	1	C6	0.9V <sub>S</sub> to V <sub>S</sub>

## Notes

1. This general address is always valid for all tuner types of this group. It is recommended not to use this address in applications where a further tuner becomes necessary, e.g. television sets with an option for picture-in-picture or satellite television.
2. If the AS pin is left floating, the internal bias will automatically set the address to C2.

## PROGRAMMABLE DIVIDER SETTINGS (BYTES 1 AND 2)

Divider ratio:

$$N = 16 \times \{f_{RF(pc)} + f_{IF(pc)}\}, \text{ where (pc) is picture carrier and } f_{RF} \text{ and } f_{IF} \text{ are expressed in MHz.}$$

$$f_{osc} = N/16 \text{ (MHz).}$$

$$N = (8192 \times n13) + (4096 \times n12) + (2048 \times n11) + (1024 \times n10) + (512 \times n9) + (256 \times n8) + (128 \times n7) + (64 \times n6) + (32 \times n5) + (16 \times n4) + (8 \times n3) + (4 \times n2) + (2 \times n1) + n0$$

## VHF/UHF television tuner

UV1316

## CONTROL BYTE 1

CP can be set to either 0 (low current) or 1 (high current).

Charge pump settings:

CP = 1, for fast tuning

CP = 0, for moderate speed tuning with slightly better residual oscillator FM.

## CONTROL BYTE 2

BAND SWITCHING	BIT <sup>(1)</sup>							
	P0	P1	P2	P3 <sup>(2)</sup>	P4	P5	P6	P7
Low band	X	X	X	0	0	1	0	1
Mid band	X	X	X	0	1	0	0	1
High band	X	X	X	0	1	1	0	0

**Notes**

1. X = don't care; P0 to P7 are output ports on the PLL device.
2. P3 must be set 0, because at this combined input/output port, the address voltage is applied.

## TELEGRAM EXAMPLES (WRITE MODE)

Start - Adb - Ack - Db1 - Ack - Db2 - Ack - Cb1 - Ack - Cb2 - Ack - Stop.

Start - Adb - Ack - Cb1 - Ack - Cb2 - Ack - Db1 - Ack - Db2 - Ack - Stop.

Start - Adb - Ack - Db1 - Ack - Db2 - Ack - Cb1 - Ack - Stop.

Start - Adb - Ack - Db1 - Ack - Db2 - Ack - Stop.

Where:

Start = start condition

Adb = address byte

Db1 = divider byte 1

Db2 = divider byte 2

Cb1 = control byte 1

Cb2 = control byte 2

Stop = stop condition.

**Remark:** for channel selection involving band switching, and to ensure smooth tuning to the desired channel without causing unnecessary charge pump action, it is recommended to consider the difference between wanted channel frequency ( $f_w$ ) and the current channel frequency ( $f_c$ ):

- If  $f_w > f_c$ , use telegram as:  
Start - Adb - Ack - Db1 - Ack - Db2 - Ack - Cb1 - Ack - Cb2 - Ack - Stop.
- If  $f_w < f_c$ , use telegram as:  
Start - Adb - Ack - Cb1 - Ack - Cb2 - Ack - Db1 - Ack - Db2 - Ack - Stop.

Unnecessary charge pump action will result in very low tuning voltage ( $V_T \approx 0$  V) which may drive the oscillator to extreme conditions.

## VHF/UHF television tuner

UV1316

**READ mode**

The in-lock flag can be read by setting the R/W bit to 1.

BYTE	BITS								
	7 MSB	6	5	4	3	2	1	0 LSB	A <sup>(1)</sup>
Address byte	1	1	0	0	0	MA1	MA0	R/W <sup>(2)</sup>	A
Status byte	POR <sup>(3)</sup>	FL <sup>(4)</sup>	I2 <sup>(5)</sup>	I1 <sup>(5)</sup>	I0 <sup>(5)</sup>	A2 <sup>(6)</sup>	A1 <sup>(6)</sup>	A0 <sup>(6)</sup>	A

**Notes**

1. A = Acknowledge.
2. R/W bit = 0 for WRITE mode, R/W bit = 1 for READ mode.
3. POR = Power On Reset. POR is internally set to 1 in case  $V_S$  drops below 3 V. The POR bit is reset when an end of data is detected by the PLL IC.
4. FL = In-lock flag; FL = 1: loop is phase-locked. The loop must be phase-locked during at least 8 periods of the internal 7.8125 kHz reference frequency before the FL flag is internally set to 1.
5. I2, I1 and I0 = digital information for I/O ports P2, P1 and P0 respectively.
6. A2, A1 and A0 = not used.

## TELEGRAM EXAMPLES (READ MODE)

Start - Adb - Ack - STB - Ack - STB - - Stop (no Ack from processor = End-of-data).

Start - Adb - Ack - STB - - Stop (no Ack from processor = End-of-data).

Where:

STB = Status byte.

VHF/UHF television tuner

UV1316

**Tuning supply voltage**

Pin 9 must be set to a typical tuning voltage of 33 V (maximum 35 V and minimum 30 V). Alternatively, a constant current of 1 to 1.5 mA can also be applied. Figure 3 shows an alternative supply from a 140 V source. The Zener diode prevents the tuning voltage at pin 9 from exceeding 33 V.

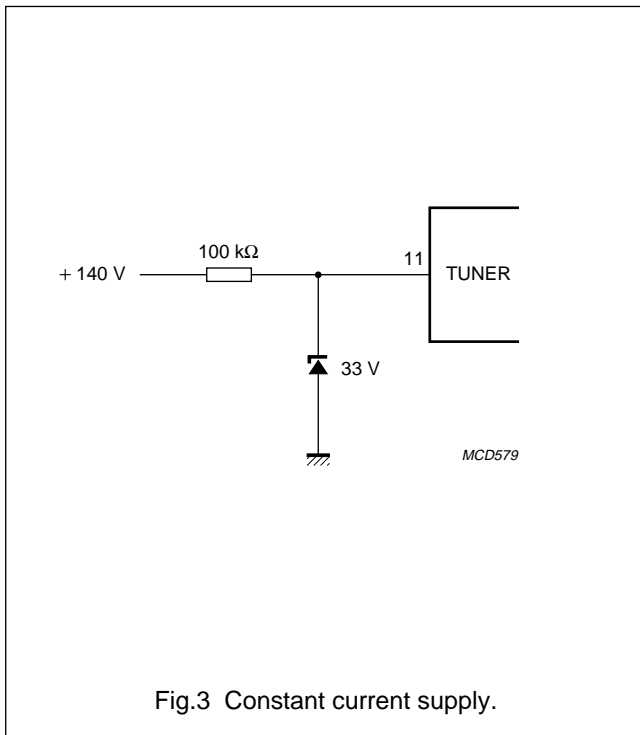

**I<sup>2</sup>C-bus load**

The UV1316 contains a series resistor ( $R = 100 \Omega$ ) in the SCL and SDA lines. Both lines also have a capacitive load of typical 56 pF (see Fig.4).

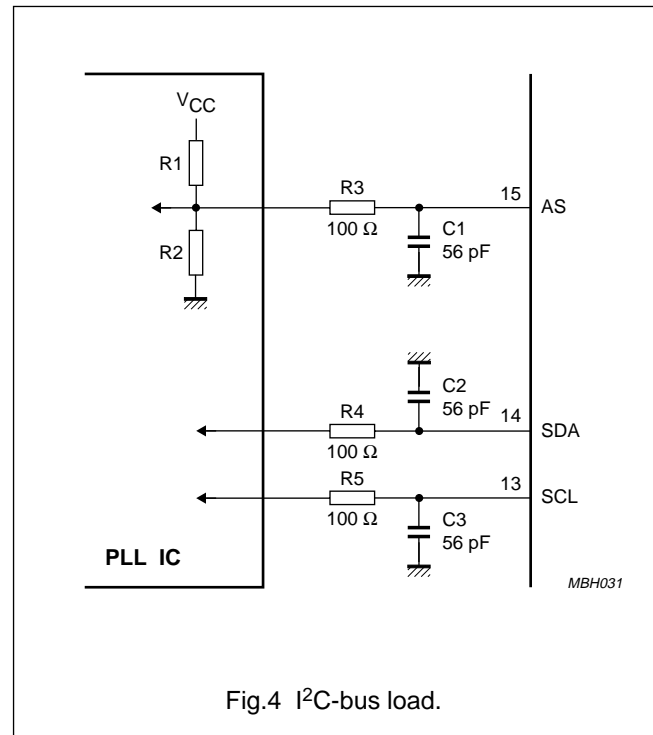

**IF bandwidth**

The typical IF bandwidth is 12 MHz.

**IF output impedance**

The IF output impedance at 36.15 MHz is  $73+j40.4 \Omega$  for symmetrical versions. For asymmetrical versions it is  $73+j48.2 \Omega$ .

**IF load**

The minimum permissible resistive load is 1 kΩ, the maximum capacitive load is 22 pF.

To guarantee optimal signal handling performance the reactive load of the IF circuitry (interconnections, saw filter) has to be tuned to tuner IF centre frequency.

The IF output is to be maintained at 105 dBμV maximum. In case this limit is exceeded, the tuner gain should be reduced accordingly.

VHF/UHF television tuner

UV1316

Automatic gain control (AGC)

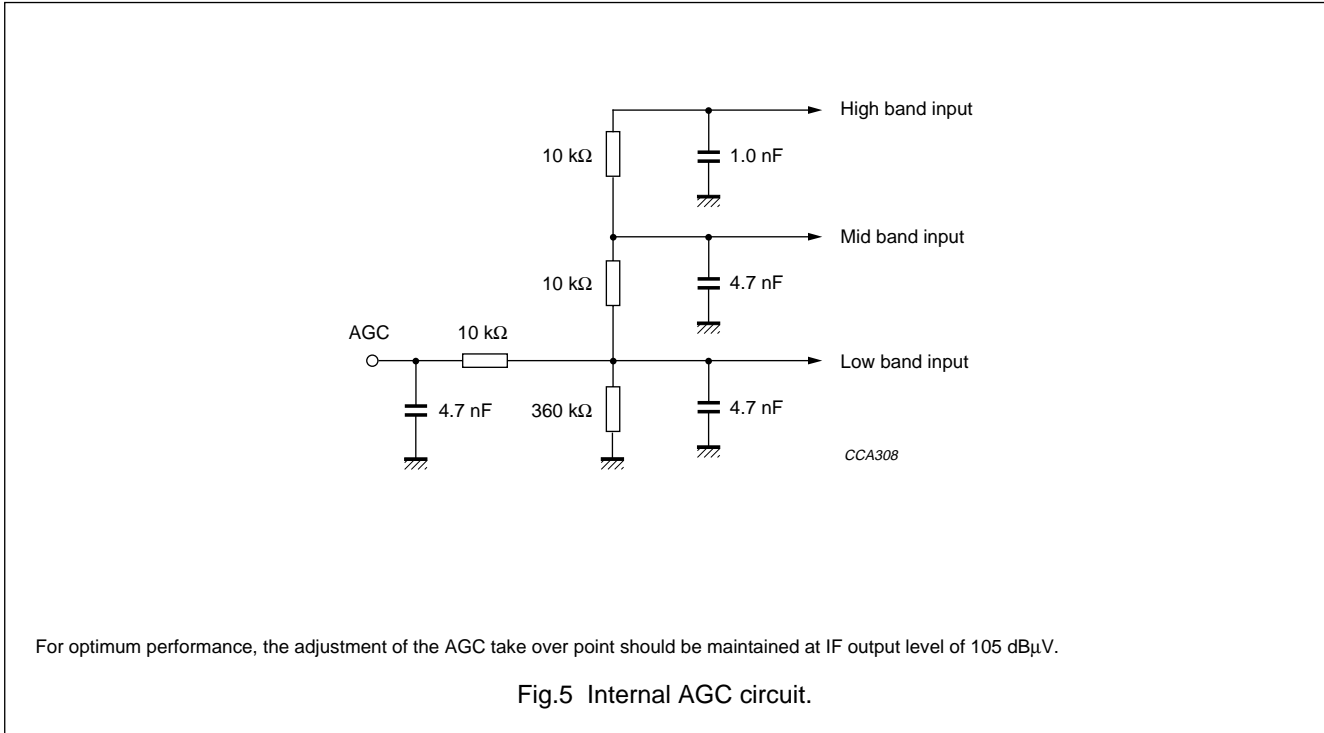

Fig.5 Internal AGC circuit.

TYPICAL AGC CURVES

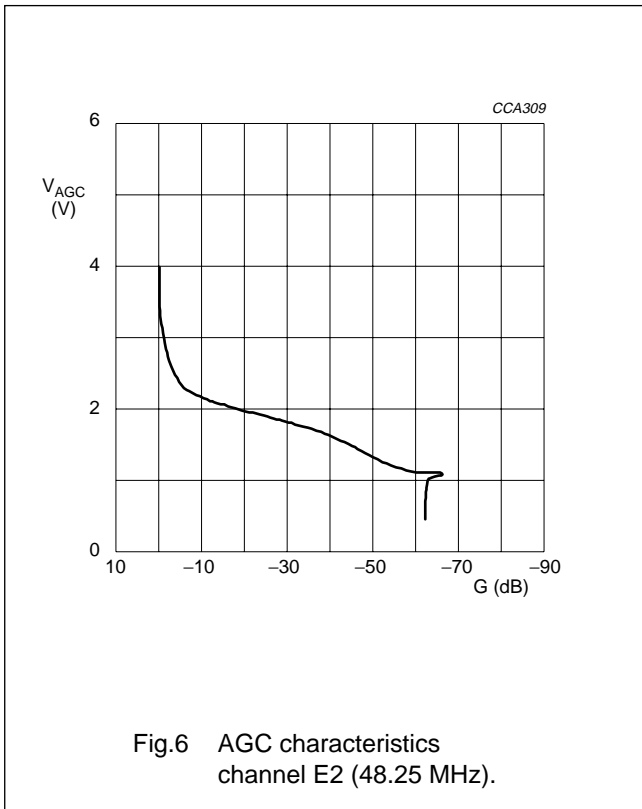

Fig.6 AGC characteristics channel E2 (48.25 MHz).

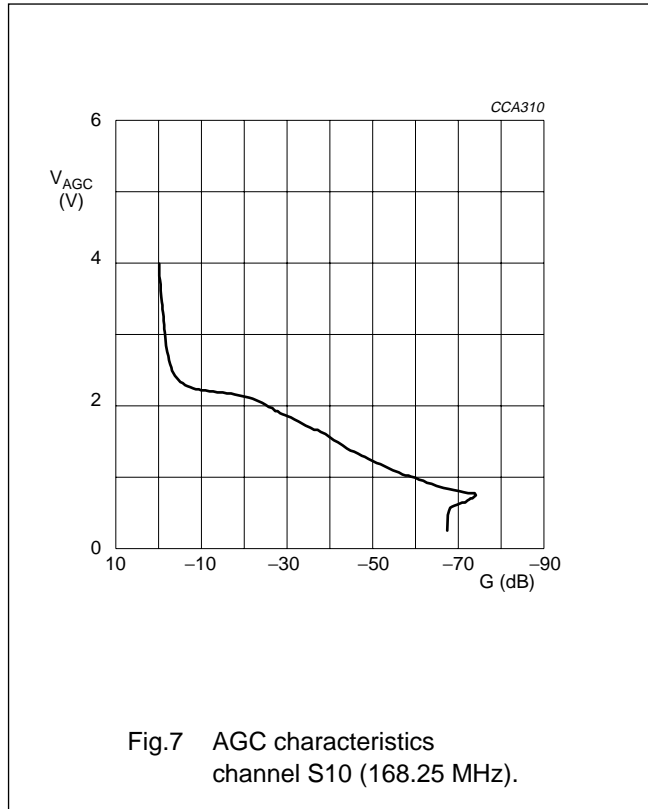
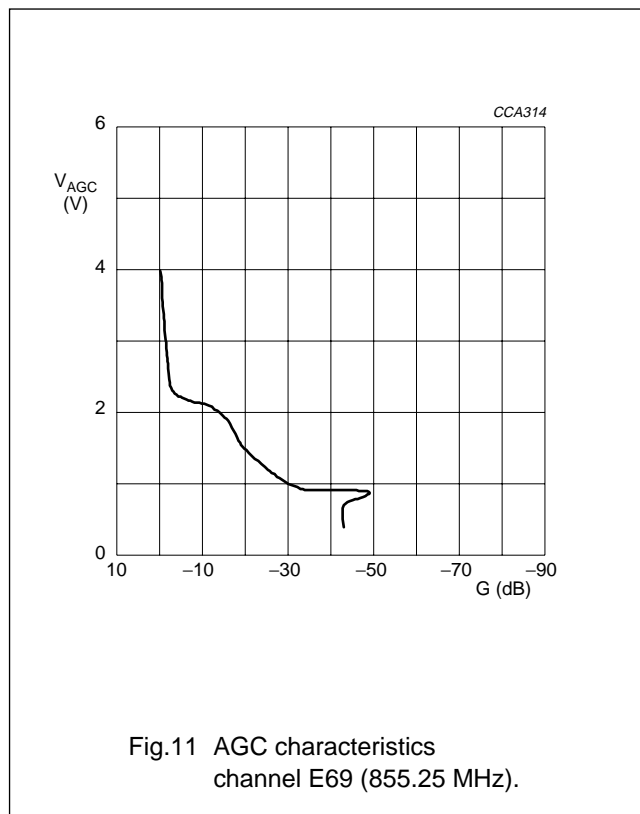
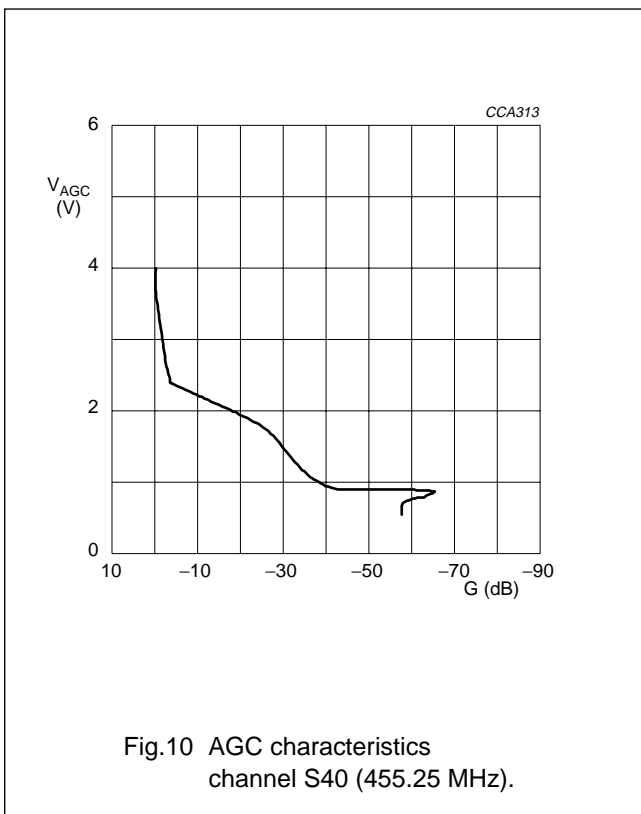
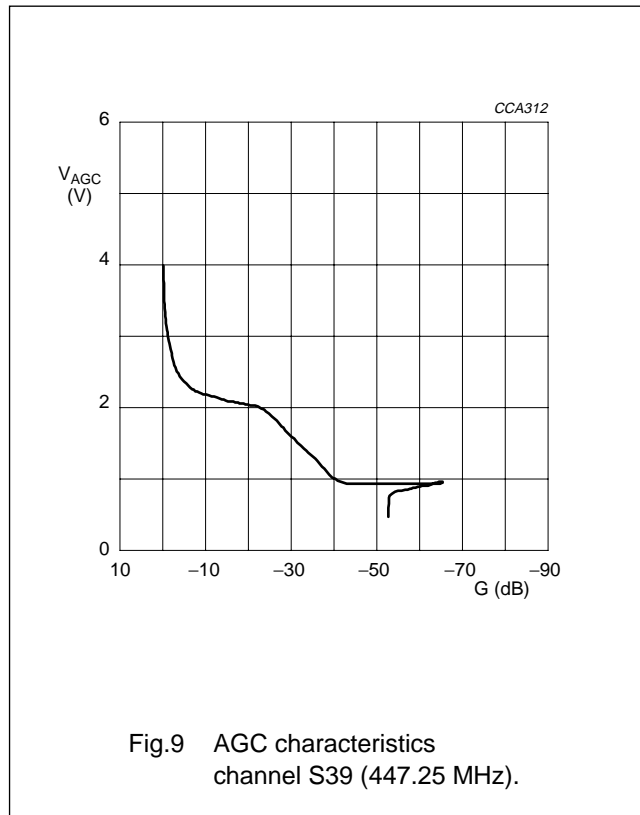
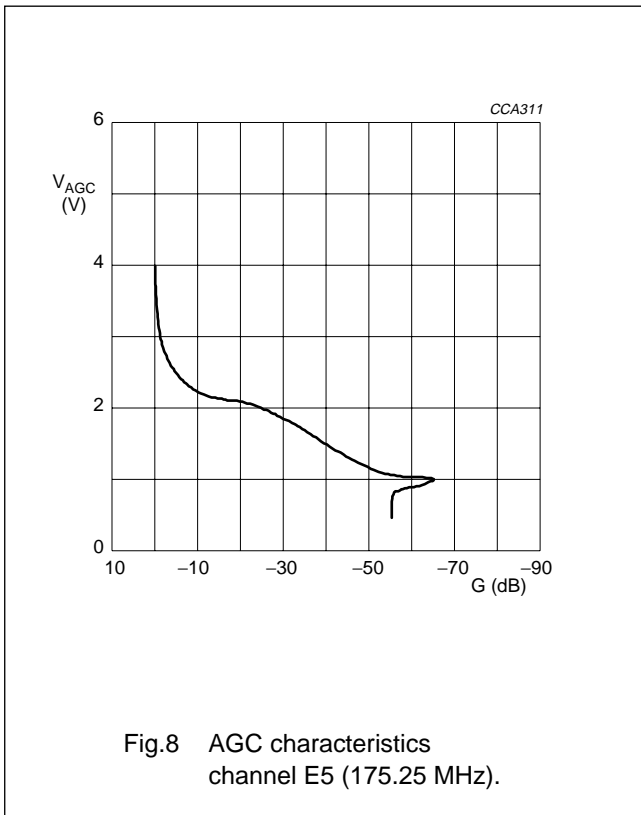

Fig.7 AGC characteristics channel S10 (168.25 MHz).

VHF/UHF television tuner

UV1316



VHF/UHF television tuner

UV1316

MECHANICAL DATA

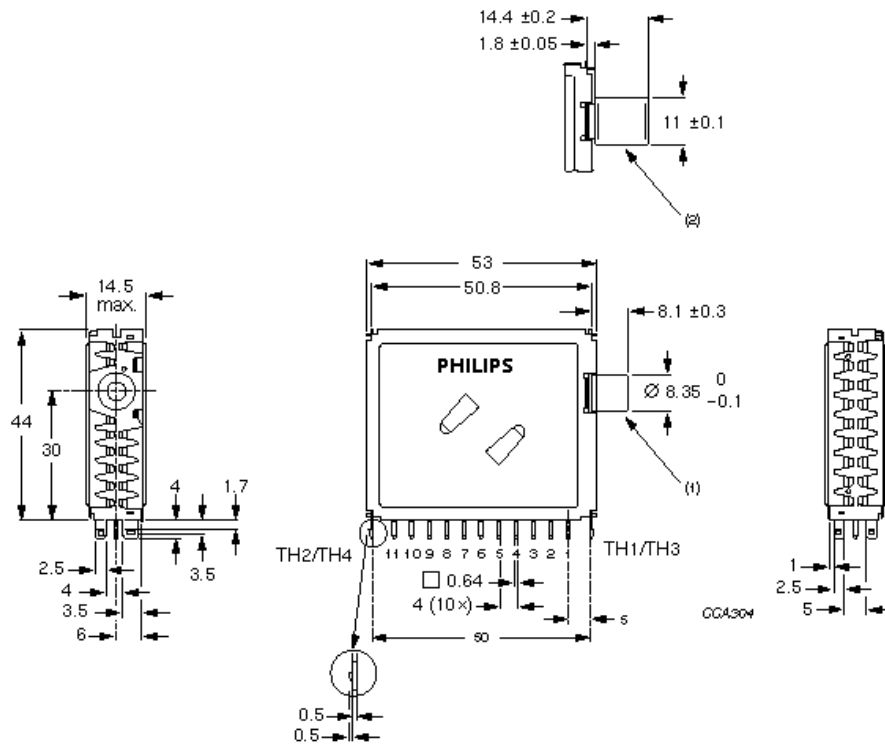

Dimensions in mm.

- (1) Standard phono socket female 75 Ω.
- (2) Alternative IEC connection.

Fig.12 Mechanical outline.

VHF/UHF television tuner

UV1316

**Aerial connections**

Standard-phono socket female 75 Ω or IEC (female).

**Solderability**

The solderability of pins and mounting tags when tested initially and after 16 hours steam ageing in accordance with "IEC 68-2-20", test Ta, method 1 (solder bath 235 °C for 2 s), results in a wetted area of 95%. No de-wetting will occur when soldered at 260 °C for 5 s.

**Resistance to soldering heat**

The product will not be damaged when tested in accordance with "IEC 68-2-20", test Tb, method 1A (solder bath 260 °C for 10 ±1 s).

**Mass**

Approximately 35 g.

**Robustness of pins**

The pins will not be damaged when tested in accordance with "IEC 68-2-21":

- Test Ua1, tensile of 10 N in axial direction
- Test Ua2, thrust of 4 N in axial direction.

**Punching pattern of chassis PCB**

For optimal mounting of the tuner to a PCB the following punching pattern is recommended (see Fig.13).

The tuner must be mounted without clearance between the tuner supporting surface and the printed wiring board. When mounted in this way, the tuner must be soldered to the printed circuit board (PCB). This can be achieved by pressing the unit vertically on the PCB during soldering.

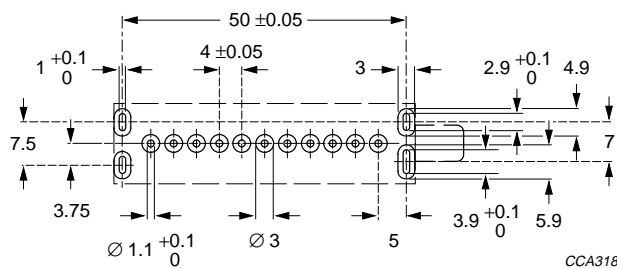

Dimensions in mm.

Fig.13 Punching pattern seen from solder side.

## VHF/UHF television tuner

UV1316

**DEFINITIONS**

<b>Data sheet status</b>	
Objective specification	This data sheet contains target or goal specifications for product development.
Preliminary specification	This data sheet contains preliminary data; supplementary data may be published later.
Product specification	This data sheet contains final product specifications.
<b>Application information</b>	
Where application information is given, it is advisory and does not form part of the specification.	

**LIFE SUPPORT APPLICATIONS**

These products are not designed for use in life support appliances, devices, or systems where malfunction of these products can reasonably be expected to result in personal injury. Philips customers using or selling these products for use in such applications do so at their own risk and agree to fully indemnify Philips for any damages resulting from such improper use or sale.

# Philips Components – a worldwide company

**Argentina:** Ierod, BUENOS AIRES,  
Tel. (541) 786 7635, Fax. (541) 786 9367.

**Australia:** Philips Components Pty Ltd, NORTH RYDE,  
Tel. (02) 805 4455, Fax. (02) 805 4466.

**Austria:** Philips Components m.b.H., WIEN,  
Tel. (01) 601 01 12 12, Fax. (01) 60 101 12 10.

**Belgium:** Philips Nederland B.V., EINDHOVEN, NL.,  
Tel. (31) 40 2783 749, Fax. (31) 40 2788 399.

**Belarus:** Philips Office Belarus, MINSK,  
Tel. (5172) 200 915, Fax. (5172) 200 773.

**Brazil:** Philips Components, SÃO PAULO,  
Tel. (011) 821 2333, Fax. (011) 829 1849.

**Canada:** Philips Electronics Ltd., SCARBOROUGH,  
Tel. (0416) 292 5161, Fax. (0416) 754 6248.

**Chile:** Philips Chilena S.A., SANTIAGO,  
Tel. (02) 77 38 16, Fax. (02) 735 35 94.

**China:** Philips Company, SHANGHAI,  
Tel. (21) 485 0600, Fax. (21) 485 1015.

**Colombia:** Iprelenso Ltda, SANTAFE DE BOGOTA,  
Tel. (57) (1) 345 8713, Fax. (57) (1) 345 8712.

**Denmark:** Philips Components A/S, COPENHAGEN S,  
Tel. (32) 883 333, Fax. (31) 571 949.

**Finland:** Philips Components, ESPOO,  
Tel. (9) 0-615 800, Fax. (9) 0-615 80920.

**France:** Philips Composants, SURESNES,  
Tel. (01) 4099 6161, Fax. (01) 4099 6427.

**Germany:** Philips Components G.m.b.H., HAMBURG,  
Tel. (040) 2489 1330, Fax. (040) 2489 1426.

**Greece:** Philips Hellenique S.A., TAVROS,  
Tel. (01) 4894 339/(01) 4894 911, Fax. (01) 4815 180.

**Hong Kong:** Philips Hong Kong, KOWLOON,  
Tel. (852) 2784 3000, Fax. (852) 2784 3003.

**India:** Philips India Ltd., BOMBAY,  
Tel. (022) 4938 541, Fax. (022) 4938 722.

**Indonesia:** P.T. Philips Development Corp., JAKARTA,  
Tel. (021) 520 1122, Fax. (021) 520 5189.

**Ireland:** Philips Electronics (Ireland) Ltd., DUBLIN,  
Tel. (01) 76 40 203, Fax. (01) 76 40 210.

**Israel:** Rapac Electronics Ltd., TEL AVIV,  
Tel. (03) 6450 444, Fax. (03) 6491 007.

**Italy:** Philips Components S.r.l., MILANO,  
Tel. (02) 6752 2531, Fax. (02) 6752 2557.

**Japan:** Philips Japan Ltd., TOKYO,  
Tel. (03) 3740 5028, Fax. (03) 3740 0580.

**Korea (Republic of):** Philips Electronics (Korea) Ltd., SEOUL,  
Tel. (02) 709 -1472, Fax. (02) 709 1479.

**Malaysia:** Philips Malaysia Sdn Berhad, KUALA LUMPUR,  
Tel. (03) 757 5511, Fax. (03) 757 4880.

Philips Malaysia Sdn Berhad, PULAU PINANG,  
Tel. (04) 870 055, Fax. (04) 879 215.

**Mexico:** Philips Components, EL PASO, U.S.A.,  
Tel. (915) 772 4020, Fax. (915) 772 4332.

**Netherlands:** Philips Nederland B.V., EINDHOVEN,  
Tel. (040) 2783 749, Fax. (040) 2788 399.

**New Zealand:** Philips New Zealand Ltd., AUCKLAND,  
Tel. (09) 849 4160, Fax. (09) 849 7811.

**Norway:** Norsk A/S Philips, OSLO,  
Tel. (22) 74 8000, Fax. (22) 74 8341.

**Pakistan:** Philips Electrical Industries of Pakistan Ltd., KARACHI,  
Tel. (021) 587 4641-49, Fax. (021) 577 035/587 4546.

**Philippines:** Philips Semiconductors Philippines Inc., MANILA,  
Tel. (02) 810 0161, Fax. (02) 817 3474.

**Poland:** Philips Poland Sp. z.o.o., WARSZAWA,  
Tel. (22) 612 2594, Fax. (22) 612 2327.

**Portugal:** Philips Portuguesa S.A.

Wire Wound Components: OVAR,  
Tel. (056) 5800 331, Fax. (056) 5860 018.

Other Philips Components: LINDA-A-VELHA,  
Tel. (01) 416 3160/416 3333, Fax. (01) 416 3174/416 3366.

**Russia:** Philips Russia, MOSCOW,  
Tel. (095) 247 9124, Fax. (095) 247 9132.

**Singapore:** Philips Singapore Pte Ltd., SINGAPORE,  
Tel. (65) 350 2000, Fax. (65) 355 1758.

**South Africa:** S.A. Philips Pty Ltd., JOHANNESBURG,  
Tel. (011) 470 5911, Fax. (011) 470 5494.

**Spain:** Philips Components, BARCELONA,  
Tel. (93) 301 63 12, Fax. (93) 301 42 43.

**Sweden:** Philips Components AB, STOCKHOLM,  
Tel. (+46) 8 632 2000, Fax. (+46) 8 632 2745.

**Switzerland:** Philips Components AG, ZÜRICH,  
Tel. (01) 488 22 11, Fax. (01) 481 77 30.

**Taiwan:** Philips Taiwan Ltd., TAIPEI,  
Tel. (02) 388 7666, Fax. (02) 382 4382.

**Thailand:** Philips Electronics (Thailand) Ltd., BANGKOK,  
Tel. (66) 2 745 4090, Fax. (66) 2 398 0793.

**Turkey:** Türk Philips Ticaret A.S., GÜLTEPE/ISTANBUL,  
Tel. (0212) 279 2770, Fax. (0212) 282 6707.

**Ukraine:** Philips Ukraine Ltd., KIEV,  
Tel. (044) 476 0297, Fax. (044) 476 6991.

**United Kingdom:** Philips Components Ltd., DORKING,  
Tel: (01306) 512 000, Fax. (01306) 512 345.

**United States:** Philips Components, JUPITER,  
Tel. (561) 745 3300, Fax. (561) 745 3600.

For literature: (800) 447 3762.

Display and Wire Wound Components, ANN ARBOR,  
Tel. (313) 996 9400, Fax. (313) 761 2776.

**Uruguay:** Philips Components, MONTEVIDEO,  
Tel. (02) 704 044, Fax. (02) 920 601.

**For all other countries apply to:** Philips Components,  
Marketing Communications, P.O. Box 218, 5600 MD EINDHOVEN,  
The Netherlands, Fax. +31-40-2724 547.

COD07

© Philips Electronics N.V. 1996

All rights are reserved. Reproduction in whole or in part is prohibited without the prior written consent of the copyright owner.

The information presented in this document does not form part of any quotation or contract, is believed to be accurate and reliable and may be changed without notice. No liability will be accepted by the publisher for any consequence of its use. Publication thereof does not convey nor imply any license under patent- or other industrial or intellectual property rights.

Printed in The Netherlands

*Let's make things better.*

**Philips  
Components**



**PHILIPS**