

Humidity and temperature measurement system using a low-cost Universal Transducer Interface

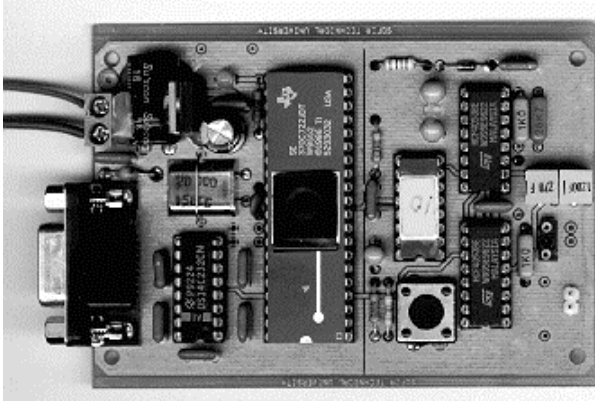

Introduction

The use of an Universal Transducer Interface (UTI) greatly simplifies electronic measurement of almost all kind of electronic sensors (capacitors, platinum resistors, thermistors, resistive bridges and potentiometers). The chip operates with power supply in the range 3,3 - 5,5 V and converts the analogue signal in pulse sequence with logic levels directly compatible with microcomputers

inputs. Its current consumption is below 2,5 mA during operation and greatly reduces up to 1 μ A in Power-down mode. The achieved 14 bit accuracy satisfies almost all sensor applications and eliminates the need of expensive instrumentation amplifiers and other analogue circuitry in front of the ADC of the microcontroller. The one-wire digital signal interface between the UTI and the microprocessor also facilitates the DC isolation or distance signal transmission where needed.

The circuit described herein illustrates how the UTI can be used in Humidity and Pressure measurement system. Nevertheless that the Texas Instrument's TMS370 single chip microcontroller is used the information is sufficiently general for use of most microcontrollers for its function.

The sensors

The humidity sensor used converts the relative humidity in capacity in the range from 300 pF for 0% to 370 pF for 100%. It has the linearity of 2% and operating temperature from - 40 $^{\circ}$ C to 110 $^{\circ}$ C . A thermistor of 1k Ohm at 25 $^{\circ}$ C is used as a temperature transducer.

Function

The board shown in figure 1 is designed to provide humidity and pressure measurement. The results are sent to the host computer by a 3-wire RS232 interface. The system has the capability to perform humidity or temperature measurement or both. It can be configured for only one measurement of the selected values or for continues measurement cycle. The internal mean average of up to 8 results is also included. Slow or fast measurement mode can be used.

Detailed circuit description

The supply Voltage

The supply voltage for the system can be in the range from 8 V up to 30 V. It is stabilised by a MC7805 fixed voltage regulator in order to give the necessary 5V power supply for the digital part of the system. The +5V analogue power supply is provided by filtering the digital supply. Nevertheless the MUX used can operate with single supply voltage, their parameters are much better

in dual supply. The negative power supply is the trade-off we should pay the usage of a low-cost MUX. The -5V are delivered from the -10V power charge pump of MAX232 interface chip filtered with a low-pass filter and stabilized with a zener diode. The overall system consumption is approximately 45 mA.

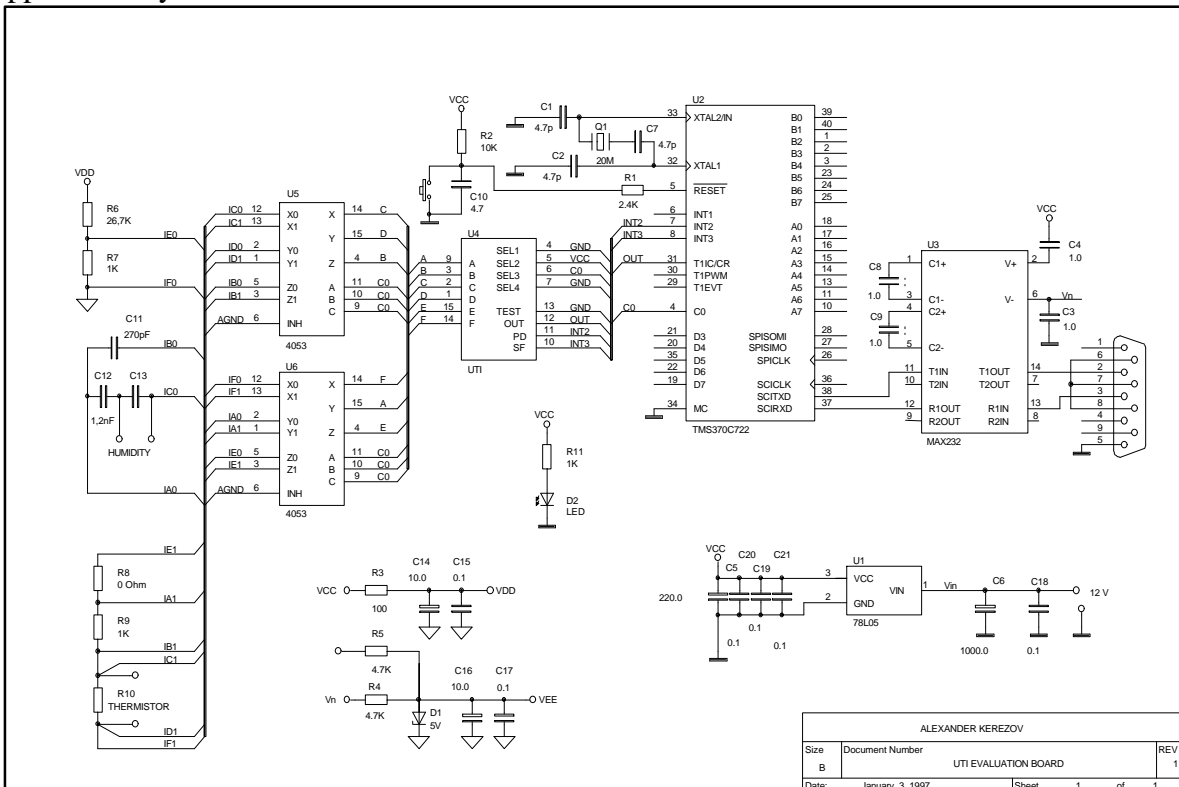

The analogue part

The analogue condition of transducers signal and analogue to digital conversion are achieved by the use of the UTI. Humidity and temperature sensors are switched alternatively on the UTI inputs by an analogue multiplexes. A low cost MUX are used in order to reduce the total system cost.

The digital part

Texas Instrument's TMS370C722 single chip microcontroller is used as a core of the measurement system operating at 20MHz clock. It has an incorporated Input capture timer function which greatly simplifies the measurement of the pulse sequences from the UTI output. This gives the resolution of 200 ns in pulse width measurement. The other control signals for the UTI are provided by a general purpose digital outputs of the microcontroller.

Elimination of EMC problems

The low power consumption itself contributes to the EMC. The suppression of interference on the supply lines is done by blocking capacitors. Further reduction can be achieved by putting ferrite coil on the supply wires. Analogue power supplies are divided from the digital ones by a low-pass filters. All the lines on the PCBoard are kept as short as possible thus reducing the antenna effect. A solid ground layer prevents the currents loops. The highest frequencies are found in the clock generator. That's why the crystal oscillator is situated as close as possible to the microprocessor clock pins. Further reduction of the electromagnetic emission is achieved by surrounding the clock wires with ground layer.

RS232 interface

The RS232 interface is based on the hardware SCI subsystem. The 0-5V to RS232 levels translation is done by a single supply MAX232 interface chip. The standard non-return to zero standard is used, transmission rate is 19200 Baud, no parity, one stop bit.

Program algorithm

The flow-chart of the system software is shown on the figure

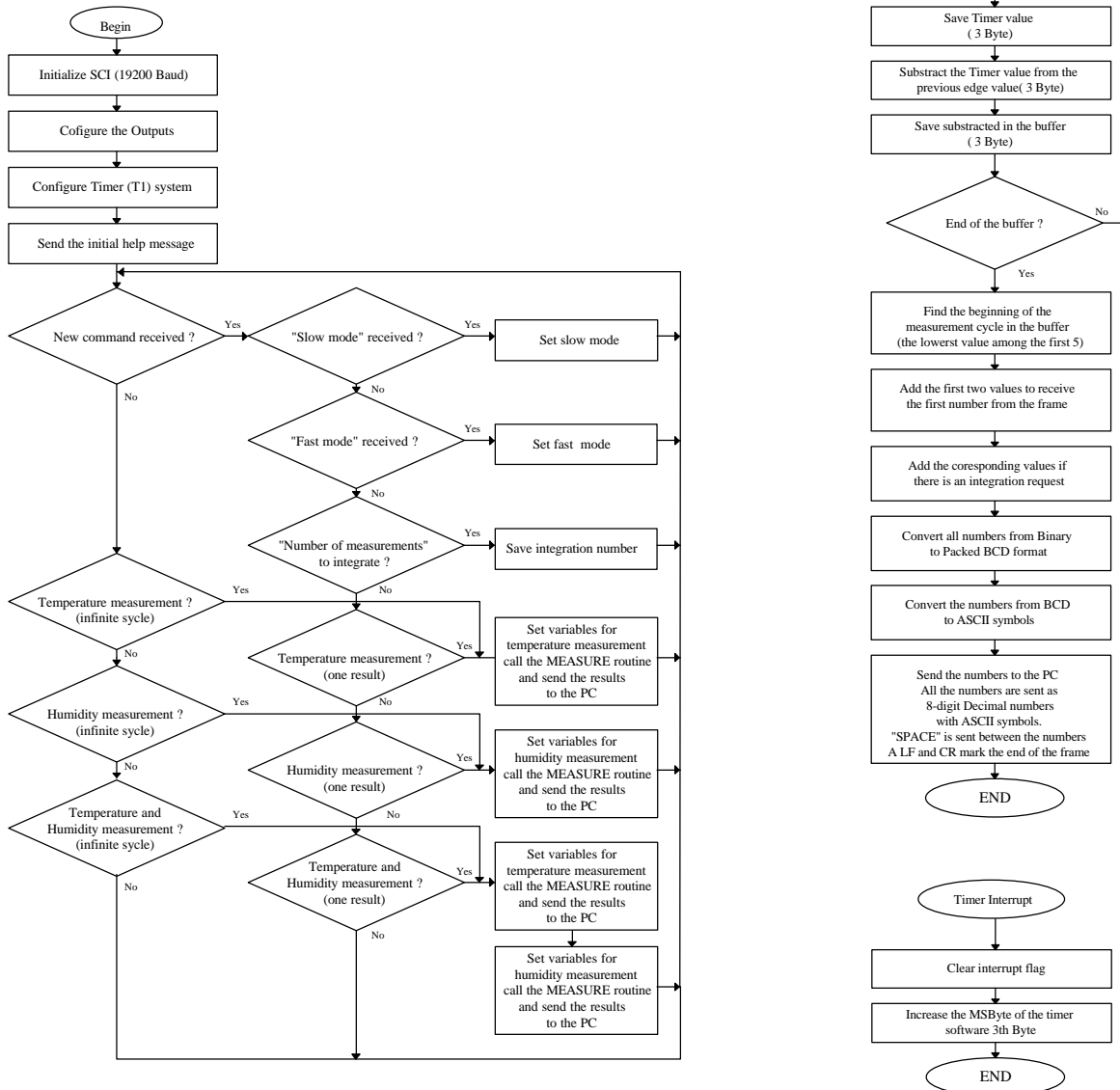

The program can be divided in two major parts - Control & PC communication routines and Measurement routines.

Control & PC communication routines: that part of the program is responsible for the conditioning of the UTI and for the communication with the Personal Computer through RS232 interface. The recognition of a new command received from the PC is done by checking Receive Buffer Register Ready Flag. No interrupt connected with the SCI is enabled. The TMS370 outputs are changed according to the command received in order to put the UTI in the necessary mode.

Measurement routines: the measurement of the different phases of the UTI is based on the Input Capture function of TMS370. On the rising edge of the signal the value of the 16-bit timer is "captured" in hardware in the 16-bit capture register and later is read by the program from that register. On every Overflow interrupt of the 16-bit timer another 8-bit sell in incremented in software thus creating a 24-bit counter. A dedicated software logic is implemented in order to eliminate the problem of eventually changing this sell between reading the hardware Capture register and this "Most significant byte" of the timer.

The Timer overflow interrupt is enabled and its only function is to increment the "Most significant byte" sell in order to have a 24 bit timer system.

System performance

The quantisation process error is:

Fast mode: - Capacitance - the lowest number is approximately 11 000, which means more then 13 bit quantisation precision (5MHz clock).
 - Resistance - the lowest number is approximately 6 500, which means more then 12 bit quantisation precision (5MHz clock).

Slow mode: - Capacitance - the lowest number is approximately 90 000, which means more then 16 bit quantisation precision (5MHz clock).
 - Resistance - the lowest number is approximately 50 000, which means more then 15 bit quantisation precision (5MHz clock).

The standard deviation in fast mode without internal average is 0,13% for capacity measurement and 0,10% for resistance measurement and respectively 0,08% and 0,03% in slow mode (100 measurements).

Conclusion

The use of UTI greatly simplifies the interfacing of a sensor with the microcontroller. It reduces the total system cost by eliminating the expensive analogue components without degrading the sensors precision.

PC Board layout

