

BP 275 PV modules provide cost-effective photovoltaic power for general use, operating DC loads directly or, in an inverter-equipped system, AC loads. Its features include the strongest frame in the industry, time-tested monocrystalline silicon solar cells, and a high-capacity multipurpose junction box. With 75 watts of nominal maximum power, the BP 275 is well-suited to utility grid-connected building facades and roof systems, telecommunication systems, pumping and irrigation, cathodic protection, remote villages and homes, and land-based navigation aids. Its 36 series-connected cells charge 12V batteries efficiently in virtually any climate.

It is available as the BP 275U and 275H, with two types of junction box as described below.

Proven Materials and Construction

BP Solar's quarter-century of field experience shows in every aspect of this module's construction and materials:

- 36 monocrystalline silicon solar cells configured as one 36-cell string (bypass diodes are included);
- Cells are laminated between sheets of ethylene vinyl acetate (EVA) and high-transmissivity low-iron 3mm tempered glass;
- Frame strength exceeds requirements of certifying agencies.

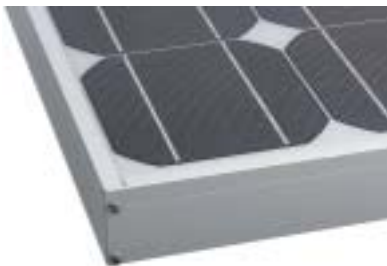

Clear-Anodized Universal Frame

Output Options

The BP 275 is offered with two types of junction box.

BP 275U output is via our Type A junction box. This junction box is raintight (IP54 rated) and accepts PG13.5 or 1/2" nominal conduit or cable fittings. Its volume (411cc, 25 cubic inches) and 6-terminal connection block enable most system array connections (putting modules in series or parallel) to be made right in the junction box. Options include:

- oversize terminal block which accepts conductors up to 25mm² (AWG #4); standard terminals accept up to 6mm² (AWG #10);
- Solarstate™ charge regulator.

BP 275H output is via our Type B junction box, which is raintight (IP65 rated) and features a convenient flip screw-tight lid. It is equipped with a versatile 5-terminal Euro-style connection block with the same wiring capabilities as the Type A junction box. Two cable fittings that accept cable with a diameter between 6 -12mm are included with each BP 275H module.

Quality and Safety

Both modules are manufactured in ISO 9001-certified factories, certified by TÜV Rheinland as Class II equipment, and compliant with the requirements of IEC 61215, including:

- repetitive cycling between -40°C and 85°C at 85% relative humidity;
- simulated impact of 25mm (one-inch) hail at terminal velocity;
- a "damp heat" test, consisting of 1000 hours of exposure to 85°C and 85% relative humidity;
- a "hot-spot" test, which determines a module's ability to tolerate localized shadowing (which can cause reverse-biased operation and localized heating);
- static loading, front and back, of 2400 pascals (50 psf); front loading (e.g. snow) of 5400 pascals (113 psf).

The BP 275U and BP 275H are listed by Underwriter's Laboratories for electrical and fire safety (Class C fire rating). The BP 275U is approved by Factory Mutual Research for applications in NEC Class 1, Division 2, Groups C & D hazardous locations.

Limited Warranties

- Power output for 25 years;
- Freedom from defects in materials and workmanship for 2 years.

See our website or your local representative for full terms of these warranties.



BP 275



Electrical Characteristics¹

	BP 275	BP 270 ⁴
Maximum power (P_{max}) ²	75W	70W
Voltage at P_{max} (V_{mp})	17.0V	17.0V
Current at P_{max} (I_{mp})	4.45A	4.16A
Warranted minimum P_{max}	70W	65W
Short-circuit current (I_{sc})	4.75A	4.48A
Open-circuit voltage (V_{oc})	21.4V	21.4V
Temperature coefficient of I_{sc}	(0.065±0.015)%/°C	
Temperature coefficient of voltage	-(80±10)mV/°C	
Temperature coefficient of power	-(0.5±0.05)%/°C	
NOCT ³	47±2°C	
Maximum system voltage	600V (U.S. NEC rating) 1000V (TÜV Rheinland rating)	
Maximum series fuse rating	20A	

Notes

- These data represent the performance of typical BP 270 and BP 275 modules as measured at their output terminations. The data are based on measurements made in accordance with ASTM E1036 corrected to SRC (Standard Reporting Conditions, also known as STC or Standard Test Conditions), which are:
 - illumination of 1 kW/m² (1 sun) at spectral distribution of AM 1.5 (ASTM E892 global spectral irradiance);
 - cell temperature of 25°C.
- During the stabilization process which occurs during the first few months of deployment, module power may decrease approximately 3% from typical P_{max} .
- The cells in an illuminated module operate hotter than the ambient temperature. NOCT (Nominal Operating Cell Temperature) is an indicator of this temperature differential, and is the cell temperature under Standard Operating Conditions: ambient temperature of 20°C, solar irradiation of 0.8 kW/m², and wind speed of 1m/s.
- The power of solar cells varies in the normal course of production; the BP 270 is assembled using cells of slightly lower power than the BP 275.

BP 275 I-V Curves

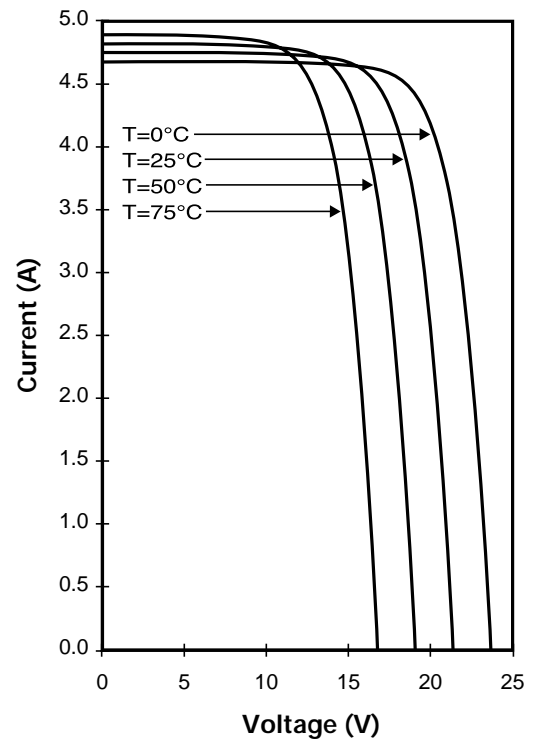

Mechanical Characteristics

Weight

BP 275 7.7 kg (17 pounds)

Dimensions

Dimensions in brackets are in inches.

Unbracketed dimensions are in millimeters

Overall tolerances $\pm 3\text{mm}$ (1/8")

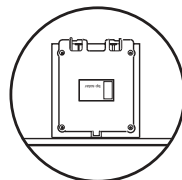
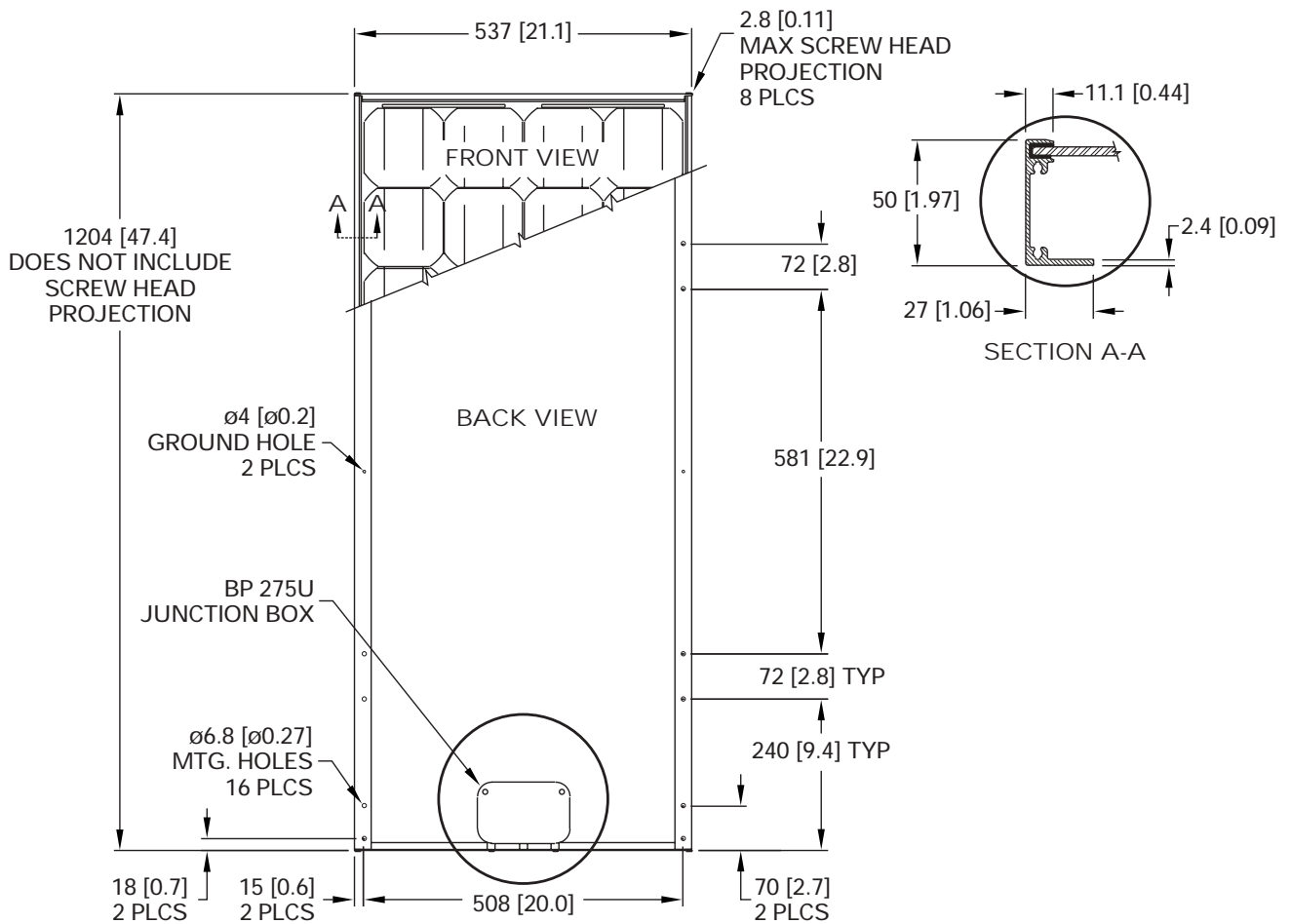

BP 275H
JUNCTION BOX

BP 275



bp solar

This publication summarizes product warranty and specifications, which are subject to change without notice and should not be used as the definitive source of information for final system design. Additional warranty and technical information may be found on our website www.bpsolar.com or may be obtained from your local representative.



Printed on recycled paper with vegetable based inks.