

harman/kardon

SUB-TS18

(HKTS 18 SUBWOOFER)

SERVICE MANUAL



harman/kardon, Inc.
250 Crossways Park Dr.
Woodbury, New York 11797

Rev1 4/2007

CONTENTS

BASIC SPECIFICATIONS	1
DETAILED SPECIFICATIONS.	2
PACKAGING.	4
CONTROLS & CONNECTIONS	5
SPEAKER CONNECTIONS.....	6
OPERATION.....	10
TEST PROCEDURE.	11
UNIT EXPLODED VIEW.	12
AMPLIFIER EXPLODED VIEW.	13
BLOCK DIAGRAM	14
DETAILED TROUBLESHOOTING.....	15
PCB DRAWINGS.	16
ELECTRICAL PARTS LIST	20
SEMICONDUCTOR PINOUTS	24
SCHEMATIC DIAGRAMS	25

SPECIFICATIONS

Amplifier Power (RMS)	200 Watts
Driver	10" (254mm) woofer, Bass Reflex Enclosure
Inputs	Stereo Line Level, dedicated Subwoofer (LFE) and Speaker Level with gold-plated binding posts
Outputs	Speaker Level with gold-plated binding posts
Frequency Response	35Hz – 120Hz (Filter switch ON) 35Hz – 450Hz (Filter switch OFF)
External Trigger Input Voltage:	3-30 Volts AC/DC
Dimensions (H x W x D)	18-7/8" x 13-3/8" x 13-3/8" (479mm x 340mm x 340mm)
Weight	35.1 lb/15.8kg

Occasional refinements may be made to existing products without notice but will always meet or exceed original specifications unless otherwise stated.

HKTS 18 Sub 200W Powered Sub/ Plate Amp

LINE VOLTAGE	Yes/No	Hi/Lo Line	Nom.	Unit	Notes
US 120vac/60Hz	Yes	108-132	120	Vrms	Normal Operation
Parameter	Nonimal Specification	Unit	QA Test Limits	Conditions	Notes
Amp Section					
Type (Class AB, D, other)	D	n/a	n/a		Bridge type amplifier, None of the speaker terminals must be connected to system GND at any time.
Load Impedance (speaker)	3.5	Ohms	n/a	Nominal	
Rated Output Power	200	Watts	150	50 - 250 Hz, 1 input driven, limiter off	
THD @ Rated Power	0.08	%	0.1	22k filter	
THD @ 1 Watt	0.15	%	0.5	22k filter	
DC Offset	5	mV-DC	20	@ Speaker Outputs	
Damping factor	16	n/a	10	Measured at amplifier board	Measured at the speaker at speaker output terminals on the amp board.
Input Sensitivity					
Input Frequency	50	Hz	n/a	Nominal Freq.	
Line (L&R) Input	220	mVrms	154 - 308	To Rated Power	Single input driven
SUB (LFE) Input	125	mVrms	87 - 175	To Rated Power	SUB (LFE) input driven only (20 dB below Line In), Single input driven
Speaker/Hi Level Input	3.4	Vrms	2.4 - 4.8	To Rated Power	
Hi Level Max. Input Voltage	32	Vrms	30	Nominal Freq., Min. Volume	
Signal to Noise Ratio					
SNR-A-Weighted	85	dB	82	relative to rated power	A-Weighting filter
SNR-unweighted	62	dB	59	relative to rated power	22k filter
SNR rel. 1W-unweighted	64	dB	59	relative to 1W Output	22k filter
Residual Noise Floor	1.2	mVrms	3.0	Volume @max, using RMS reading DMM/VOM (or A/P)	
Residual Noise Floor	0.8	mVrms	2.0	Volume @max, w/ A/P Swept Bandpass Measurement (Line freq.+ harmonics)	
Input Impedance					
Line Input (L, R,LFE)	10K	ohms	n/a	Nominal	
Speaker/Hi Level Input	4.7K	ohms	n/a	Nominal	
Filters					
L&R Fixed Low-Pass Filter	160	Hz	140 - 180	@ -6dB ref. 100Hz	3rd order fixec
SUB (LFE) Low pass Filter	270	Hz	240 - 300	@ -3dB ref. 100Hz	2nd order fixec
Subsonic filter (HPF) 3rd Order	25	Hz	22 - 28	@ -3dB ref. 30Hz	3rd order fixec
Limiter					
THD at Max. Output Power	2.0	%	5.0		
Features					
Auto - On -Off Selection Switch	YES		functional		Refer to ATO section
Phase Switch	0-180	deg	functional		
Filter On/Off Switch	YES		functional		
Volume Pot Taper (Lin/Log)	LOG		functional		A Taper
Speaker Out	YES		functional		Binding post connector L&R
2-Color LED power indicator	YES		functional		Blue: On, Amber: Stand-by
Power Switch	YES		functional		
Fuse Holder	YES		functional		
Input Configuration					
Line In (L,R)	YES		functional		Dual RCA jack
SUB (LFE)	YES		functional		RCA jack
Speaker/Hi Level In	YES		functional		Binding post connector L&R
Signal Sensing (ATO)					
Auto-Turn-On (yes/no)	YES		functional	Auto - on selection switch in Auto	
ATO Input test frequency	50	Hz	n/a	"	
ATO Level Line & SUB Input	4.0	mV	2.0 - 6.0	"	
ATO Level Speaker in	35	mV	20 - 50	"	
ATO Turn-on time	0.9	sec.	functional	Amp connected and AC on, then input signal applied	

Parameter	Nonimal Specification	Unit	QA Test Limits	Conditions	Notes
Amp Section					
ATO Turn-OFF Time	12	minutes	5 - 17	Time before muting, after signal is removed	
Power on Delay time	3	sec.	functional	AC Power Applied	
Transients/Pops					
ATO Transient	5	mV-peak	10	@ Speaker Outputs	
Turn-on Transient	500	mV-peak	700	@ Speaker Outputs	AC Line cycled from OFF to ON
Turn-off Transient	500	mV-peak	700	@ Speaker Outputs	AC Line cycled from ON to OFF
Efficiency					
Stand-by Input Power	8	Watts	12	@ nom. line voltage	Maximum allowable input power under nominal input voltage and frequency, in stand-by mode (HOT or COLD operation).
Power Consumption @ rated power	240	Watts	250	@ nom. line voltage	200 Watts @ 3.5 ohms and nominal line voltage
Protection					
Short Circuit Protection	YES		functional	Direct short at output	Amplifier should resume operation after short circuit condition is removed.
Thermal Protection	YES		functional		Any user accessible metal parts should always remain at 65 degree C or less for domestic version or 55 degree C or less for EU version.
DC Offset Protection	YES		functional	DC present at Speaker Out leads	Relay or crowbar (for driver/fire protection).
Primary Fuse Rating					
USA-Domestic	3.15	Amps	n/a	Type-T or Slo Blo (no DENTORI	User-replacable fuse with UL/SEMCO rated holder.

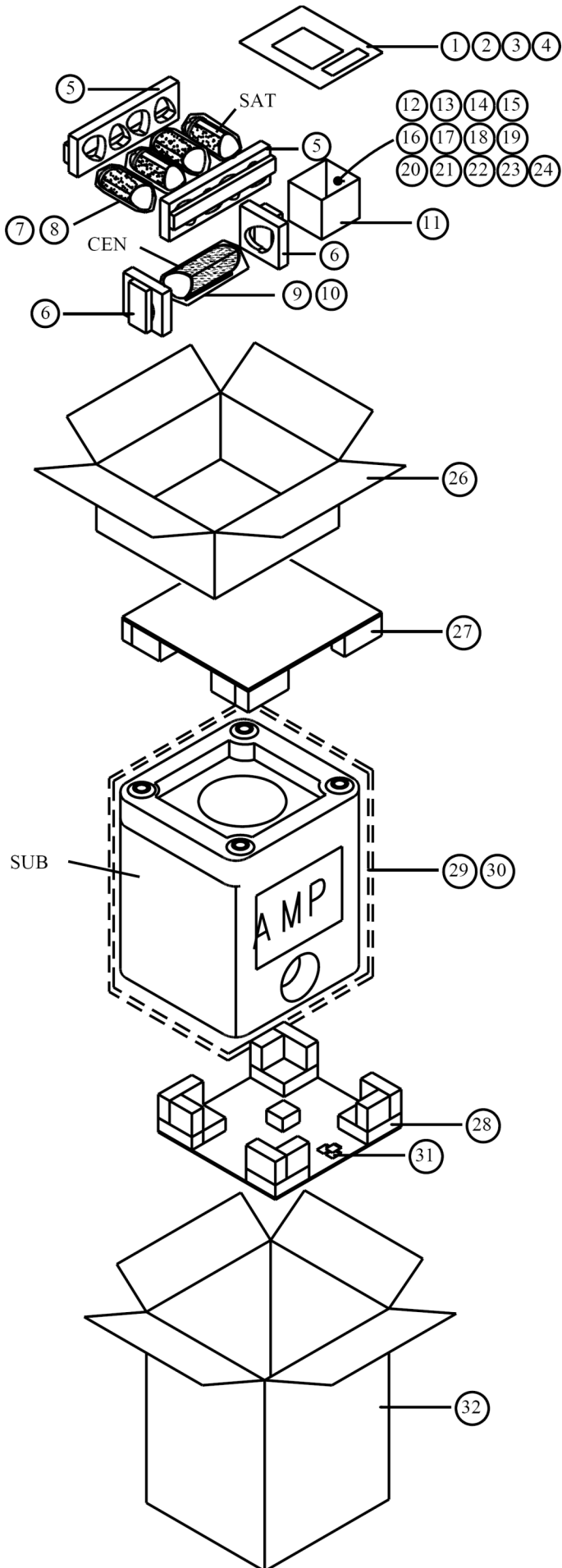

Item	Description	Part Number	Qty
1	Color Label		1.0
2	Warranty Card	405-000-00333-E	1.0
3	Warranty Card	405-000-05033-E	1.0
4	Owner's Manual	406-000-05504-E	1.0
5	Satellite Packing		1.0
6	Satellite Packing		1.0
7	Non-woven Bag		4.0
8	PE Bag		4.0
9	Non-woven Bag		1.0
10	PE Bag		1.0
11	Cardboard		1.0
12	Wall Mount Bracket	326-ABS-00108-0BAE	4.0
13	Mounting Plate	326-FE-00109-E	4.0
14	Leather Cushion	336-EVA-05405-0BAE	4.0
15	Bracket for Center	325-SPCC-05229-0BAE	1.0
16	Screw Bag for CEN Wall Bracket	371-000-05168-E	1.0
17	Terminal Cap	317-PS-00172-0BAE	4.0
18	Signal cable Purple RCA 15 ft	370-000-05034-E	1.0
19	Speaker cable 20 feet red tube	370-000-05035-E	1.0
20	Speaker cable 20 feet green tube	370-000-05036-E	1.0
21	Speaker cable 20 feet white tube	370-000-05037-E	1.0
22	Speaker cable Sat+Center 12m Gray	370-000-05038-E	1.0
23	Speaker cable Sat+Center 12m Blue	370-000-05039-E	1.0
24	Screw Bag for SAT Wall Bracket	371-000-00360-E	1.0
25	Signal Cable for Trigger	165-54505501-e	1.0
26	Inner Carton	401-000-05003-E	1.0
27	Top SUB TS18 package		1.0
28	Btm SUB TS18 package		1.0
29	Non-woven Bag		1.0
30	PO Bag		1.0
31	Dessicant		2.0
32	Outer Carton	402-000-05680-E	1.0

371-000-05168-E: 2pcs Flat head, 10mm(screw Length) x 8mm(Screw head Dim.)

371-000-00360-E: 2pcs Round head, 1/4"(screw Length) x 10.5mm(Screw head Dim.)

SUB-TS18 SUBWOOFER AMPLIFIER PANEL CONTROLS AND CONNECTIONS

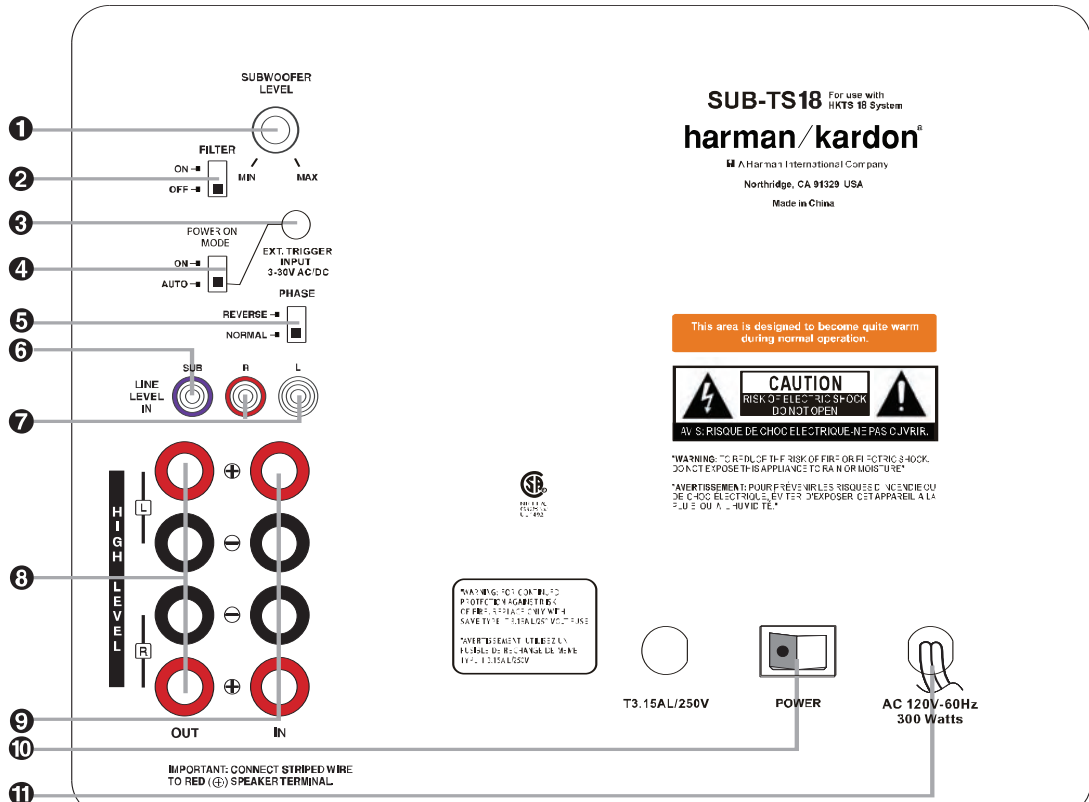

- 1 Subwoofer-Level Control
- 2 High-Cut (Low-Pass) Filter Switch
- 3 External Trigger Input
- 4 Audio-Sense On/Off Switch

- 5 Phase Switch
- 6 Line-Level Subwoofer (SUB) Input
- 7 Line-Level Full-Range Inputs
- 8 Speaker-Level Outputs

- 9 Speaker-Level Inputs
- 10 Master Power Switch
- 11 AC Power Cord

1 Subwoofer-Level Control: Volume may be adjusted using the **Subwoofer-Level Control**. Turn the control clockwise to increase the SUB-TS18's volume, or counterclockwise to decrease it.

2 High-Cut (Low-Pass) Filter Switch: Placing this switch in the **ON** position activates circuitry that cuts out all audio input signals above 120Hz, allowing the SUB-TS18 to focus its power on reproducing the low-frequency portion of the signal, avoiding

inefficiency and distortion. Engage this filter when using the **Speaker-Level Inputs 9**, or when using the **Line-Level Full-Range Inputs 7**, unless your receiver or processor processes its line-level output using a low-pass filter. The filter has no effect when the **SUB Input 6** is used.

3 External Trigger Input: Use the supplied mini-plug cable to connect the trigger output of another product to this jack. When a trigger signal between 3 and 30 volts (AC

or DC) is detected, the SUB-TS18 amplifier will turn on, even when the audio-sense feature has been activated by placing the **Audio-Sense On/Off Switch 4** in the **AUTO** position. The amplifier will remain on for about 10–15 minutes without a trigger signal.

4 Audio-Sense On/Off Switch: When placed in the **AUTO** position, and when the **Master Power Switch 10** is turned on, the SUB-TS18 will automatically turn itself on or

SUB-TS18 SUBWOOFER AMPLIFIER PANEL CONTROLS AND CONNECTIONS

place itself in the Standby mode, depending on whether it is receiving an audio signal. When this switch is placed in the **ON** position, the SUB-TS18 will remain on, whether or not it is receiving an audio signal.

An LED located on top of the SUB-TS18 indicates whether the SUB-TS18 is in the On or Standby state when used with the **Audio-Sense On/Off Switch 4** in the **AUTO** position. The LED is lit blue to indicate that the SUB-TS18 is receiving an audio signal and is turned on, and the LED is lit amber to indicate that no signal is being received and the SUB-TS18 is in the Standby mode.

When the **Audio-Sense On/Off Switch 4** is in the **ON** position, the LED will be lit blue, whether or not an audio signal is present.

When the **Master Power Switch 10** is turned off, the LED goes dark, no matter which position the **Audio-Sense On/Off Switch 4** is in.

5 Phase Switch: This switch determines whether the SUB-TS18 subwoofer's piston-like action moves in and out in phase with the main speakers. If the speakers were to play out of phase, the sound waves produced by the subwoofer would be canceled out, reducing bass response. This phenomenon depends in part on the relative placement of the speakers in the room. In most cases, the **Phase Switch 5** should be left in the **NORMAL** position. However, it does no harm to experiment with the **Phase Switch 5**, and you may leave it in the position that maximizes bass response.

6 Line-Level Subwoofer (SUB) Input: Connect the subwoofer output of a receiver with digital surround sound decoding, such as Dolby® Digital or DTS®, to this input. This input bypasses the SUB-TS18's internal crossover circuitry, and should only be used with a filtered signal. If your receiver does not have digital decoding, you should use the **Line-Level Full-Range Inputs 7** instead.

7 Line-Level Full-Range Inputs: Connect the line-level subwoofer output or preamp output(s) of your receiver or amplifier to these inputs. If your receiver does not have a separate subwoofer output, use a Y-adaptor (not supplied) to bridge the receiver's preamp output to the main amp input for that channel, and connect the long end of the adaptor to the corresponding line-level input on the SUB-TS18. If your receiver has only a single subwoofer output, you may connect it to either the left or right line-level input on the SUB-TS 18, and no Y-adaptor is needed.

8 Speaker-Level Outputs: If you are using the **Speaker-Level Inputs 9** on the SUB-TS18, you should connect these binding-post terminals to your front left and right speakers, remembering to maintain polarity by connecting the (+) terminal on the SUB-TS18 subwoofer to the (+) terminal on the speaker, and the (–) terminal on the SUB-TS18 subwoofer to the (–) terminal on the speaker. If you are not using the **Speaker-Level Inputs 9**, then connect your front left and right speakers directly to your receiver or amplifier. See pages 9 through 12 for further information on speaker connections.

9 Speaker-Level Inputs: If your receiver or amplifier does not have a line-level subwoofer output, connect these binding-post terminals to the main left and right speaker terminals of your receiver or amplifier. Remember to maintain polarity by connecting the (+) terminal on the receiver/amplifier to the (+) terminal on the SUB-TS18 subwoofer, and the (–) terminal on the receiver/amplifier to the (–) terminal on the SUB-TS18 subwoofer.

10 Master Power Switch: Place this switch in the "●" position to power-on the SUB-TS18 subwoofer. The SUB-TS18 will then be either in the Standby mode or completely on, depending on the position of the **Audio-Sense On/Off Switch 4**.

11 AC Power Cord: Make sure to plug this cord into an active, unswitched electrical outlet for proper operation of the SUB-TS18. The cord should not be plugged into the accessory outlets found on some audio components.

SPEAKER CONNECTIONS

Dolby® Digital or DTS® (or Other Digital Surround Mode) Connection

USE THIS INSTALLATION METHOD FOR DOLBY DIGITAL, DTS OR OTHER DIGITAL SURROUND PROCESSORS:

Use the line-level input jack marked **SUB** ⑥ for the low-frequency effects channel. Connect this jack to the subwoofer output or LFE output on your receiver or amplifier. Connect each speaker to the corresponding speaker terminals on your receiver or amplifier.

Make sure you've configured your surround sound processor for "Subwoofer On." The front left, front right, center and surround speakers should all be set to "Small."

When all connections have been made, plug the AC power cord on the subwoofer into an AC outlet.

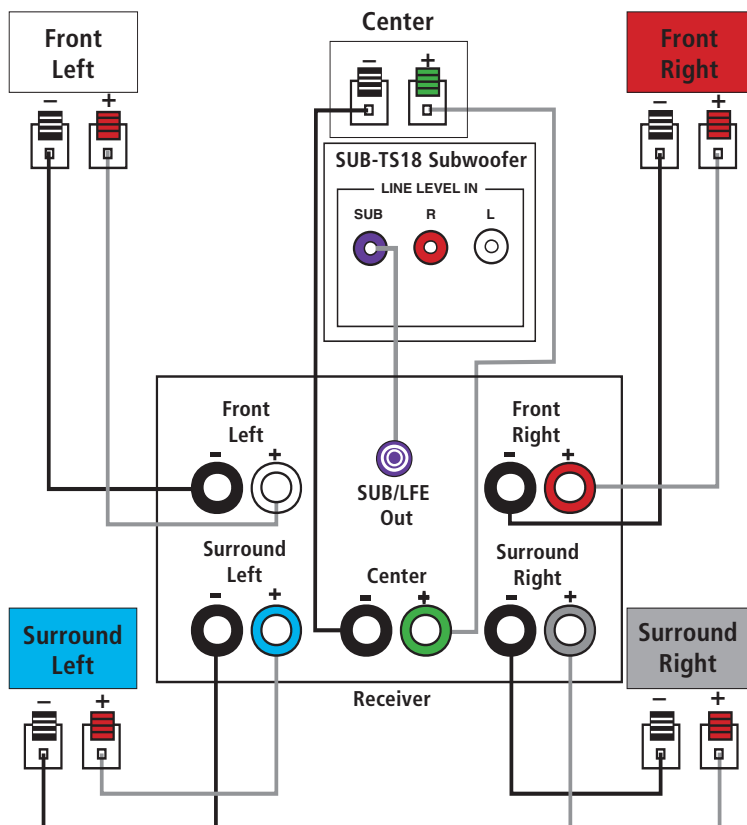

SPEAKER CONNECTIONS

Dolby Pro Logic® (Non-Digital) – Line Level

USE THIS INSTALLATION METHOD FOR DOLBY PRO LOGIC APPLICATIONS (NOT DOLBY DIGITAL, DTS OR OTHER DIGITAL PROCESSING), WHERE THE RECEIVER/PROCESSOR IS EQUIPPED WITH A SUBWOOFER OUTPUT, OR A VOLUME-CONTROLLED PREAMP (LINE-) LEVEL OUTPUT:

Use the supplied RCA-type interconnect cable to connect the line-level subwoofer output on your receiver or amplifier to either the left or right **Line-Level Full-Range Input 7** on the SUB-TS18 subwoofer. Use both the left and right inputs on the subwoofer if your receiver or processor has both left and right line-level outputs. In that case, you will need to supply a second interconnect cable.

If your receiver is equipped with line-level outputs but does not have a separate subwoofer output, use a Y-adaptor (not supplied) to bridge the receiver's preamp output to the main amp input for that channel, and connect the long end of the adaptor to the corresponding line-level input on the SUB-TS18.

IMPORTANT: Do not use the **SUB Input 6** on the subwoofer with Dolby Pro Logic processors.

If your receiver/processor has a built-in low-pass-crossover filter for the subwoofer output, you may use the **SUB Input 6** to bypass the subwoofer's internal crossover.

Connect each speaker to the corresponding speaker terminals on your receiver or amplifier.

Make sure that you have configured your surround sound processor for "Subwoofer On." The front left, front right, center and surround speakers should all be set to "Small."

When all connections have been made, plug the AC power cord on the subwoofer into an AC outlet.

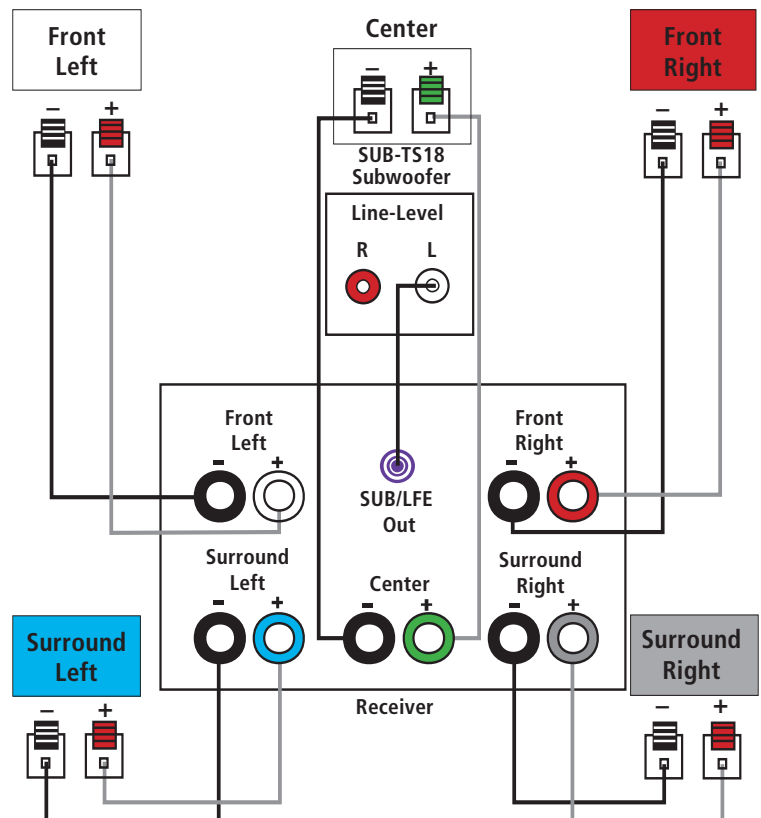

SPEAKER CONNECTIONS

Dolby Pro Logic (Non-Digital) – Speaker Level

USE THIS INSTALLATION METHOD FOR DOLBY PRO LOGIC APPLICATIONS (NOT DOLBY DIGITAL, DTS OR OTHER DIGITAL PROCESSING), WHERE THE RECEIVER/PROCESSOR DOES NOT HAVE A SUB-WOOFER OUTPUT, OR A VOLUME-CONTROLLED PREAMP (LINE-) LEVEL OUTPUT:

Connect your receiver or amplifier's front left and right speaker terminals to the left and right **Speaker-Level Input** ⑨ terminals on the SUB-TS18 subwoofer that are marked "High Level In." Connect the left and right **Speaker-Level Output** ⑧ terminals on the SUB-TS18 subwoofer that are marked "High Level Out" to the corresponding terminals on the back of your front left and right speakers.

Connect your receiver or amplifier's center and surround left and right speaker terminals to the corresponding terminals on the back of your center and surround left and right speakers.

When all connections have been made, plug the AC power cord on the subwoofer into an AC outlet.

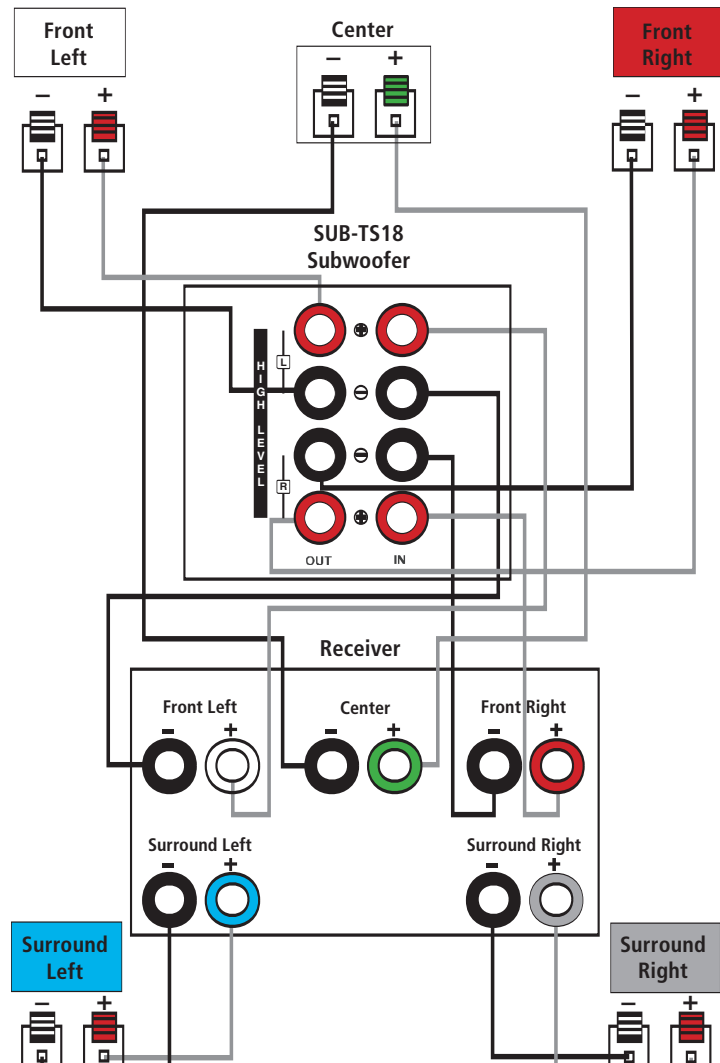

OPERATION

Move the **Master Power Switch 10** (marked **Power**) to the "●" (On) position. The SUB-TS18 subwoofer will automatically turn itself on or go into Standby mode, depending on whether or not a signal is being sent to it by your receiver or surround processor, and provided that the **Audio-Sense On/Off Switch 4** is moved down so that it is in the **AUTO** position.

When your receiver or amplifier is off, or is not sending program material to the subwoofer, the subwoofer will be in Standby mode and the LED indicator on the top of the subwoofer will turn amber. When the subwoofer senses an audio signal, it will automatically turn itself on and the LED indicator will turn blue. If the subwoofer does not sense a signal after approximately 20 minutes, it will automatically go into Standby mode.

When the **Audio-Sense On/Off Switch 4** is switched to the **ON** position, the subwoofer will remain on, whether or not program material is playing, and the LED indicator will remain lit blue.

If your receiver, processor or amplifier is equipped with a compatible trigger output, you may connect it to the SUB-TS18's **External Trigger Input 3**. When you turn on your component, if you have set it up correctly, it will send an electrical trigger signal to the SUB-TS18, which will cause the subwoofer to turn itself on, even when the **Audio-Sense On/Off Switch 4** has been placed in the **AUTO** position and no audio signal is detected.

The trigger signal must be between 3 and 30 volts, although it may be an AC or DC signal, and an AC signal may be 50Hz or 60Hz.

If you'll be away from home for an extended period of time, or if the subwoofer will not be used, switch the **Master Power Switch 10** to the **OFF** position.

Volume

Volume can be adjusted using the **Subwoofer-Level Control 1**, as shown. Turn the control knob clockwise to increase the volume of the subwoofer, and counterclockwise to decrease the subwoofer's volume.

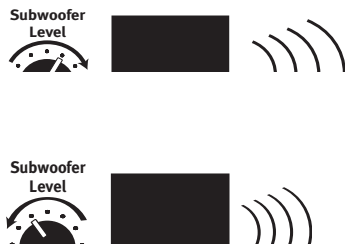

Additional Bass Adjustments

In addition to the volume adjustments described previously, the SUB-TS18 subwoofer includes a **Phase Switch 5** and a **Filter Switch 2** that can be used to adjust the bass response to suit your listening environment or taste.

In most situations, the **Phase Switch 5** should be left in the **NORMAL** position. If you suspect that the subwoofer is playing out of phase with the other speakers, which would tend to diminish bass response, try placing this switch in the **REVERSE** position. There is no harm in experimenting, and you may return the switch to the **NORMAL** position at any time. If you rearrange your room and reposition the speakers, it would be a good idea to check whether they are in phase by flipping this switch.

The **High-Cut (Low-Pass) Filter Switch 2** limits the frequencies of the audio signal inputted to the subwoofer to the low frequencies that the subwoofer reproduces best. This allows the subwoofer to perform more efficiently, and with superior bass reproduction, minimizing distortion that might occur if the subwoofer attempted to reproduce higher frequencies. This switch should be left in the **ON** position, **except**:

1. When the **SUB Input 6** is being used, in which case it has no effect, or
2. When the **Speaker-Level Inputs 9** or the **Line-Level Full-Range Inputs 7** are being used with a crossover or filter aboard the receiver or processor.

In these two circumstances, place the switch in the **OFF** position.

Test Set Up and Procedure

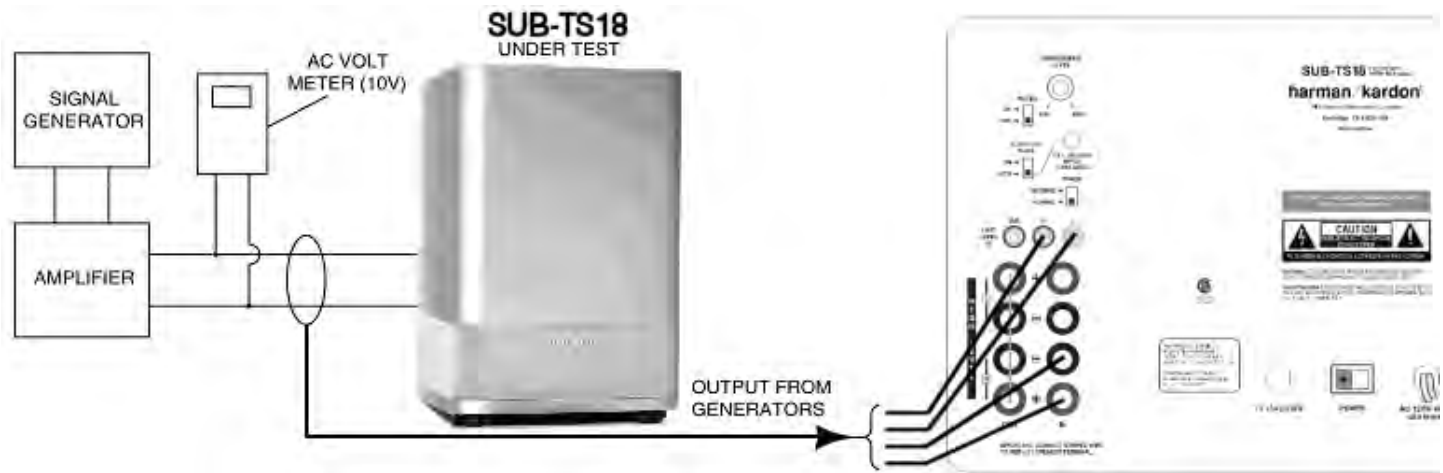

Equipment needed:

- Function/signal generator/sweep generator
- Integrated Amplifier
- Multimeter
- Speaker cables

Initial Control Settings:

- Power Switch OFF; Filter OFF
- Level MIN (Full CCW)
- Phase, Auto/On switches do not matter

General Unit Function (UUT = Unit Under Test)

- 1) From the signal generator, connect one line level (RCA) cable to the Subwoofer Line Level Input jacks L/R on the UUT. Use a Y-cable from a mono source if necessary to connect to both inputs. Do not connect to the single, purple SUB input.
- 2) Turn on generator; adjust to **60mV, 50 Hz**.
- 3) Plug in UUT; turn the power switch ON. Turn LEVEL control full clockwise (MAX)
- 4) LED should turn from Amber to Blue (on top of UUT); immediate and vigorous bass response should be heard and felt from port tube opening.
- 5) Turn off generator, turn LEVEL control full counterclockwise (MIN), and disconnect RCA cable.
- 6) Connect one pair of speaker cables to Speaker Level input terminal (IN) on UUT. Cables should be connected to an integrated amplifier fed by the signal generator.
- 7) Turn on generator and adjust so that speaker level input at the amplifier is **1.2V, 50 Hz**. Turn LEVEL control full clockwise.
- 8) LED should turn from Amber to Blue; immediate and vigorous bass response should be heard and felt from the port tube opening.

Sweep Function

- 1) Follow steps 6-8 above, using a sweep generator as a signal source.
- 2) Sweep generator from 20Hz to 300Hz. Listen to the cabinet and drivers for any rattles, clicks, buzzes or any other noises. If any unusual noises are heard, remove woofers and test.

Driver Function

- 1) Remove woofer from cabinet; detach + and - wire clips.
- 2) Check DC resistance of woofer; it should be **2.8 ohms ±10%**
- 3) Connect a pair of speaker cables to driver terminals. Cables should be connected to an integrated amplifier fed by a signal generator. Turn on generator and adjust so that speaker level output is **5.0V**.
- 4) Sweep generator from 20Hz to 1kHz. Listen to driver for any rubbing, buzzing, or other unusual noises.

EXPLODED VIEW

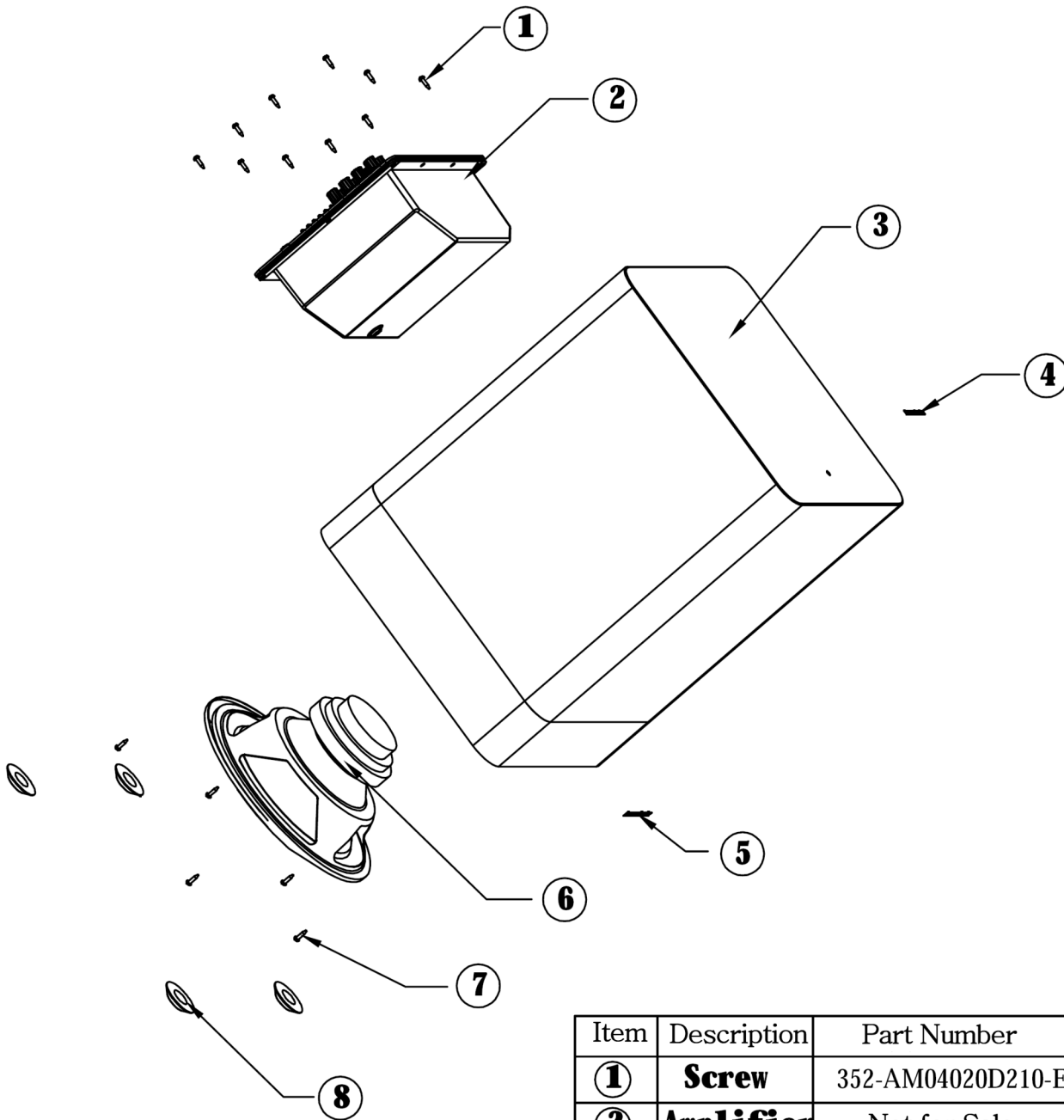

Item	Description	Part Number	Qty
①	Screw	352-AM04020D210-E	10
②	Amplifier	Not for Sale	1
③	Enclosure	Not for Sale	1
④	Logo	316-AG-00557-E	1
⑤	Logo	316-AL-00553-E	1
⑥	Woofer	25PF12DZB-DW02-E	1
⑦	Screw	352-FM04020D605-E	5
⑧	Foot Pad	320-RUB-00057-0BAE	4

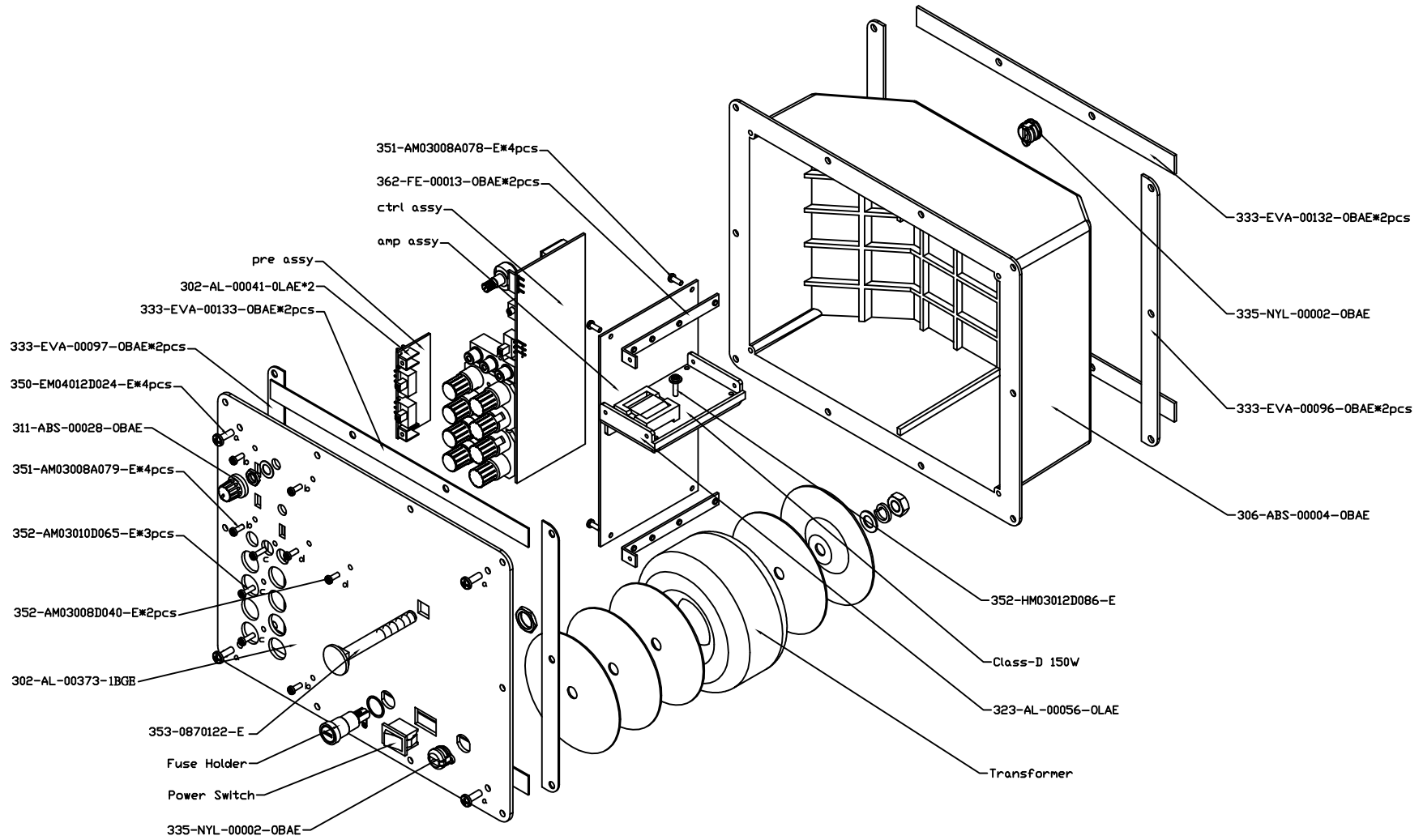

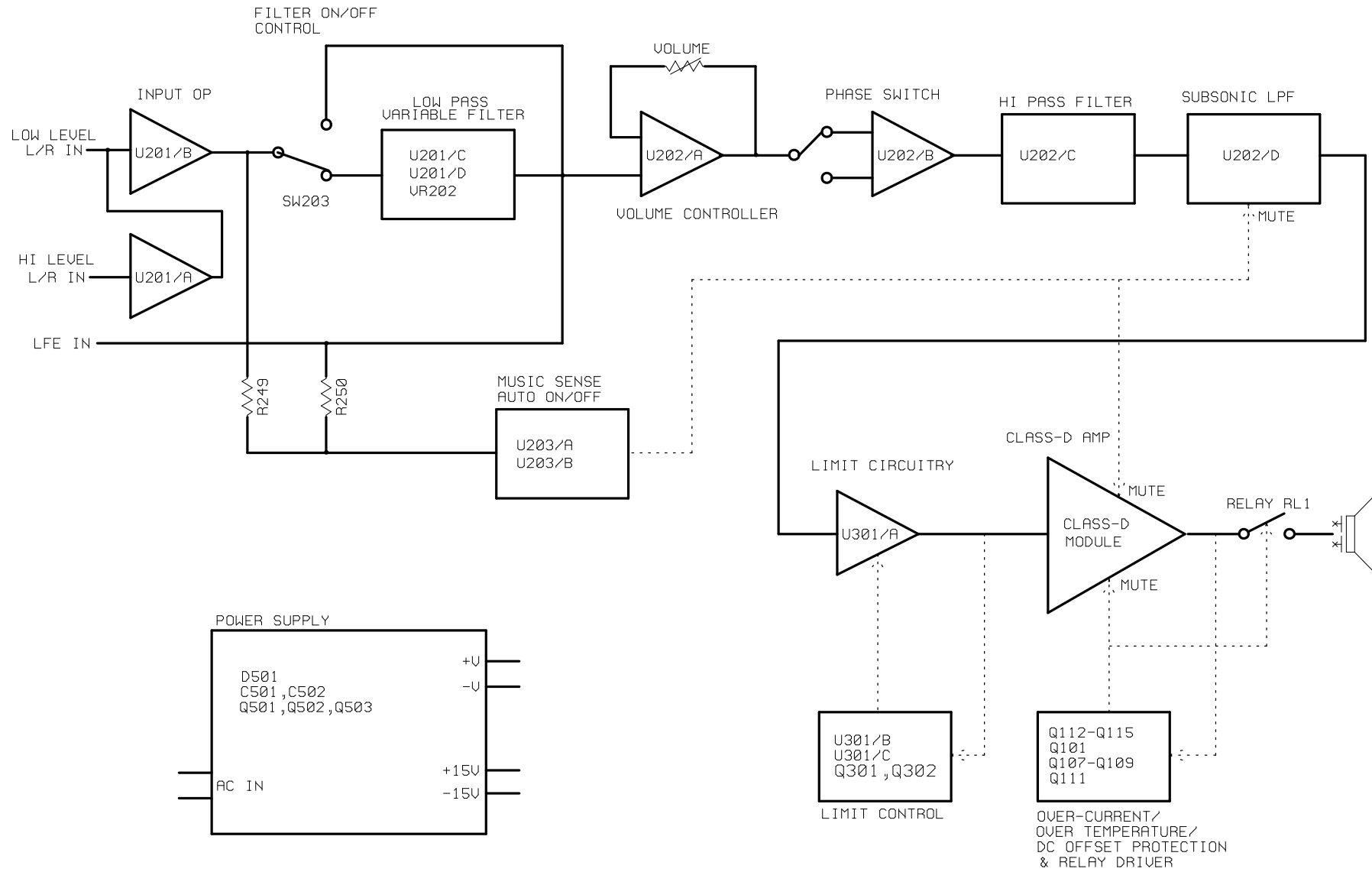

HKTS18 BLOCK DIAGRAM

SUB-TS18 (UL) AMP

Troubleshooting Flow Chart

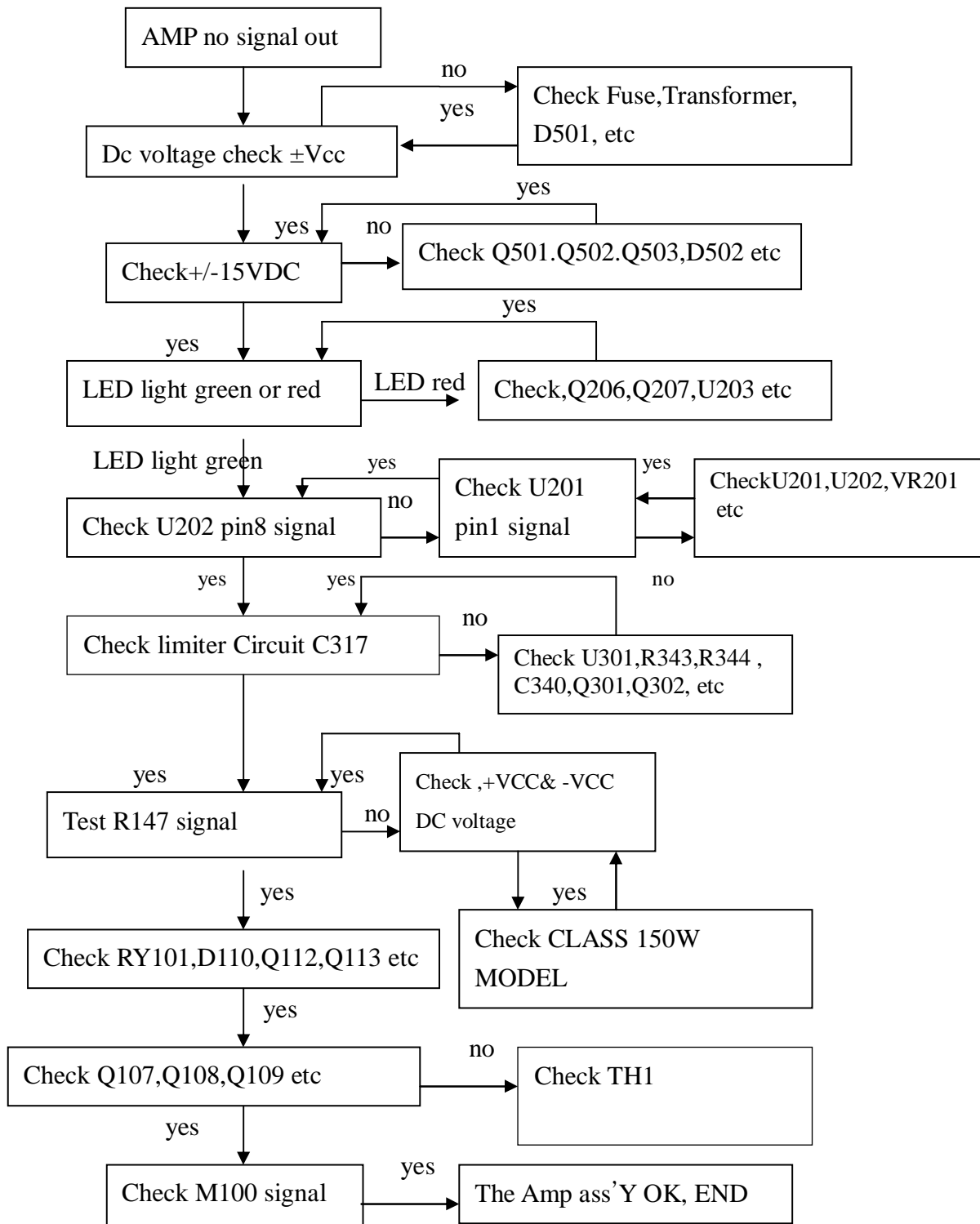

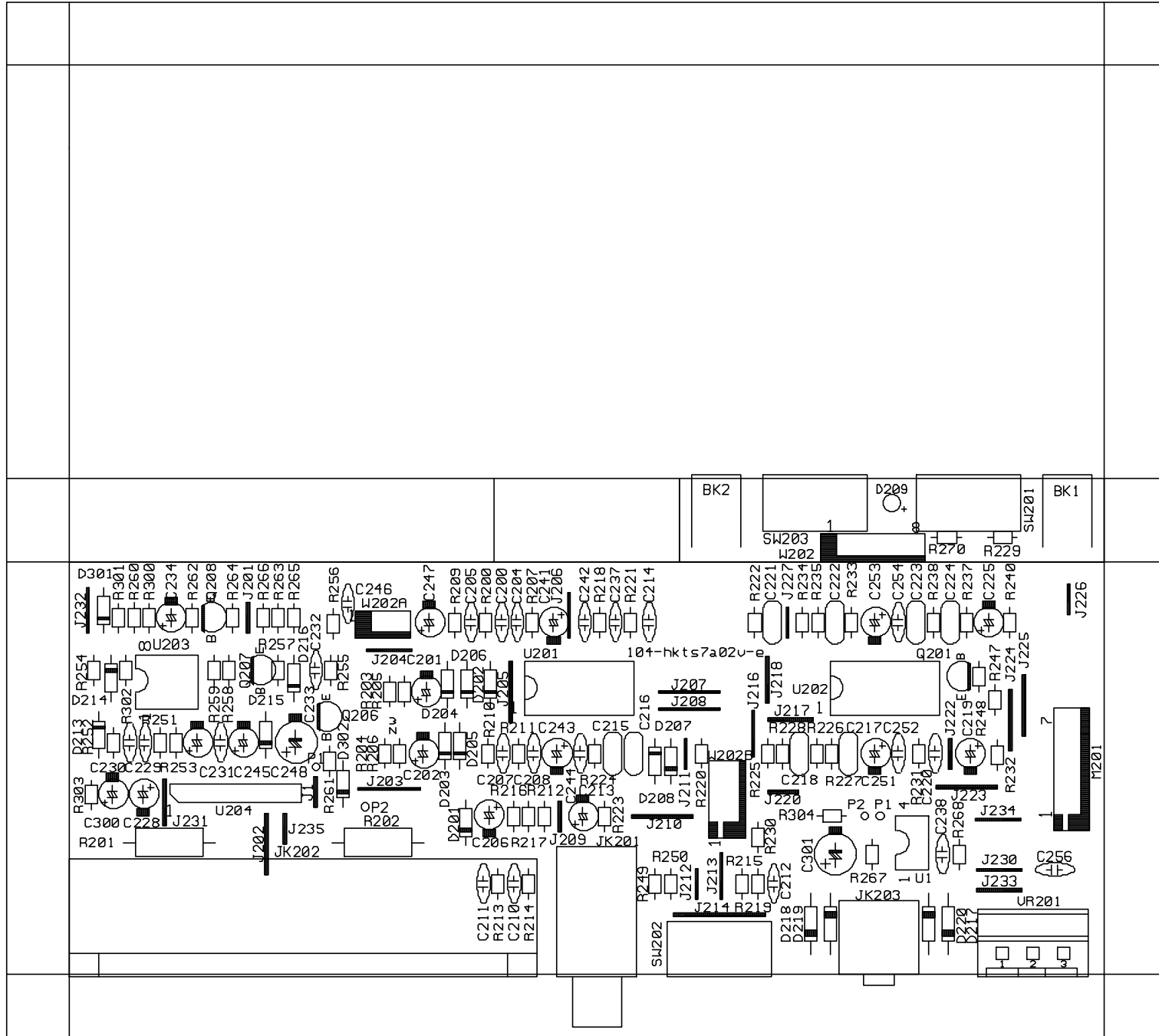

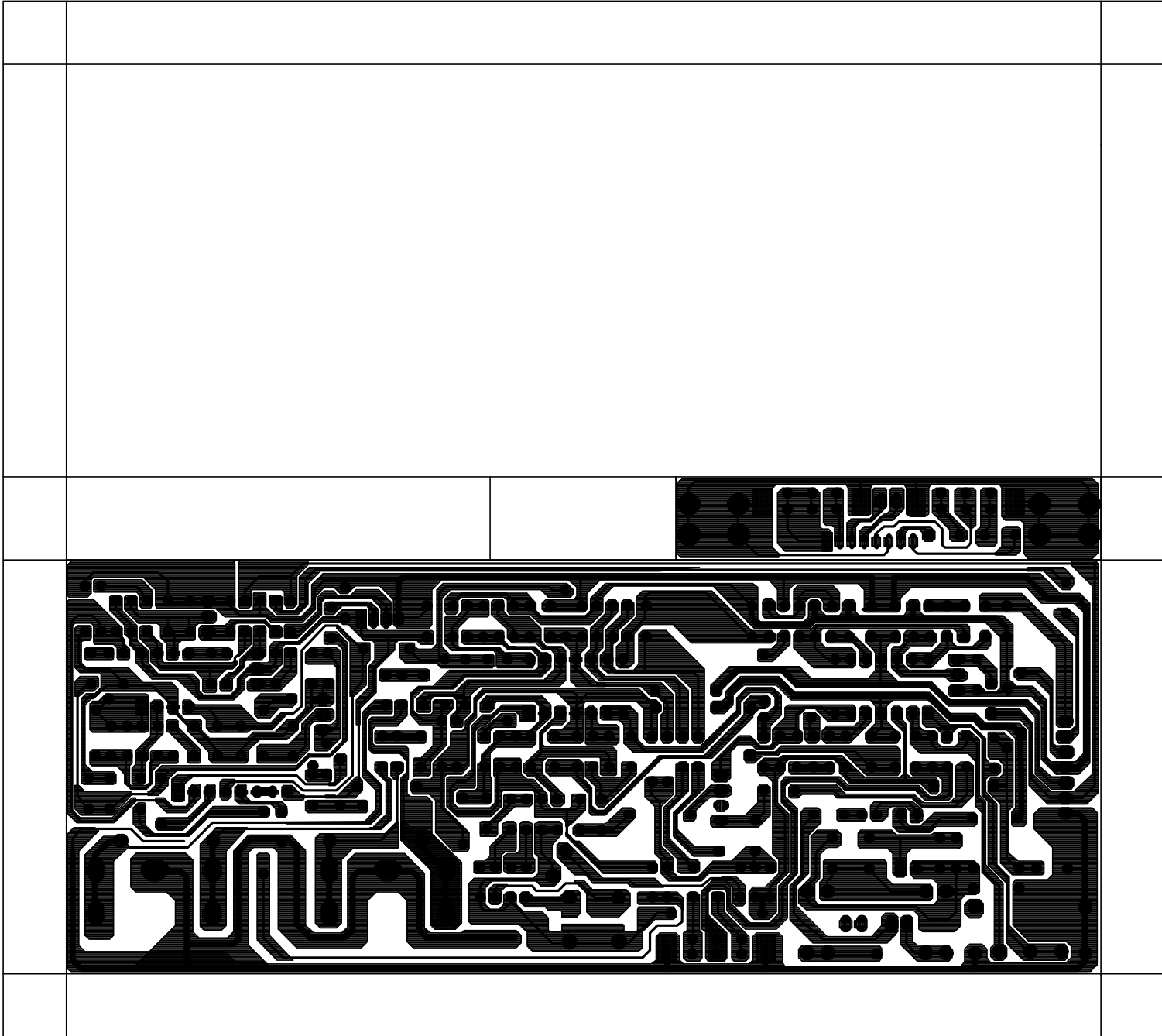

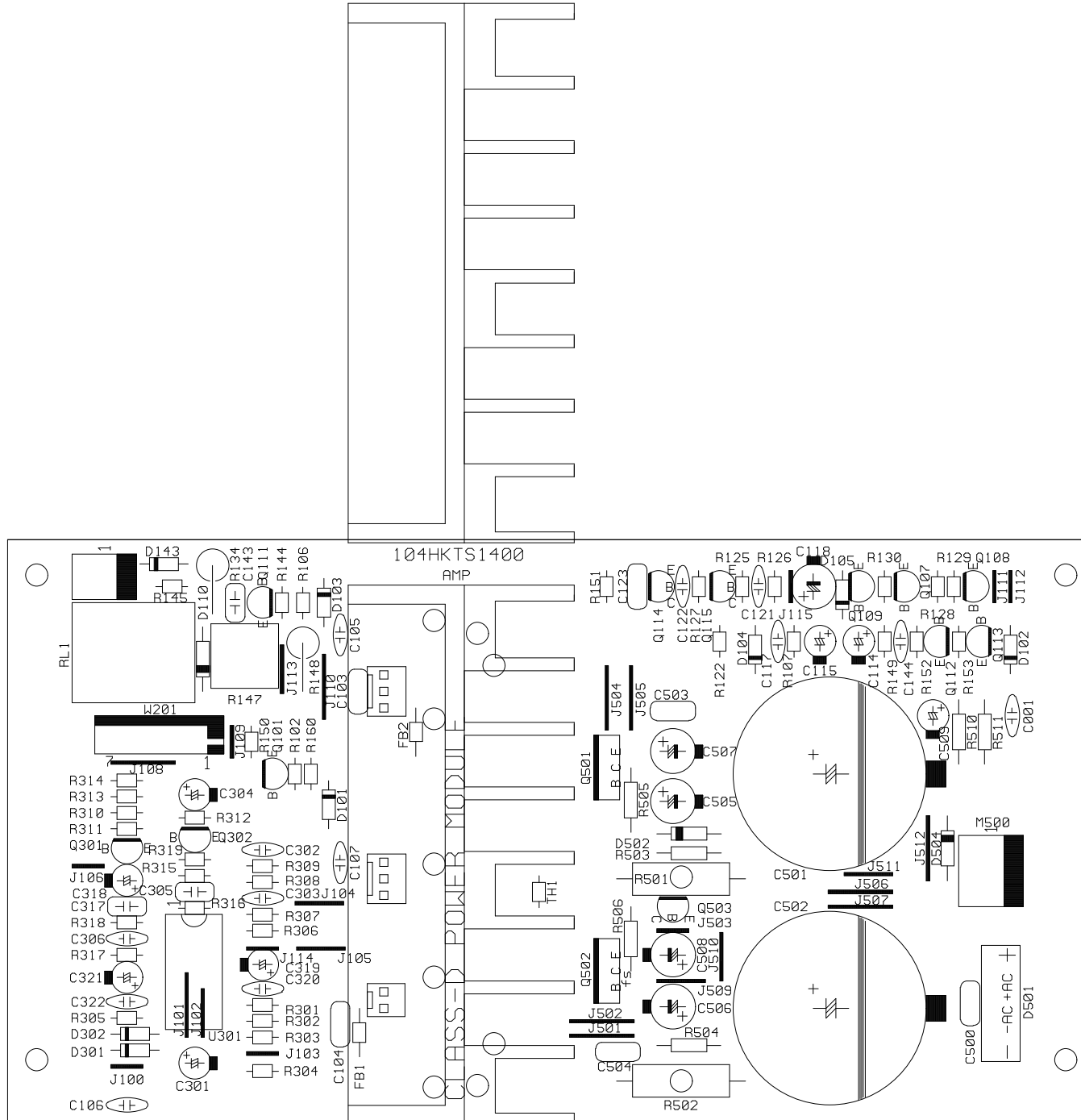

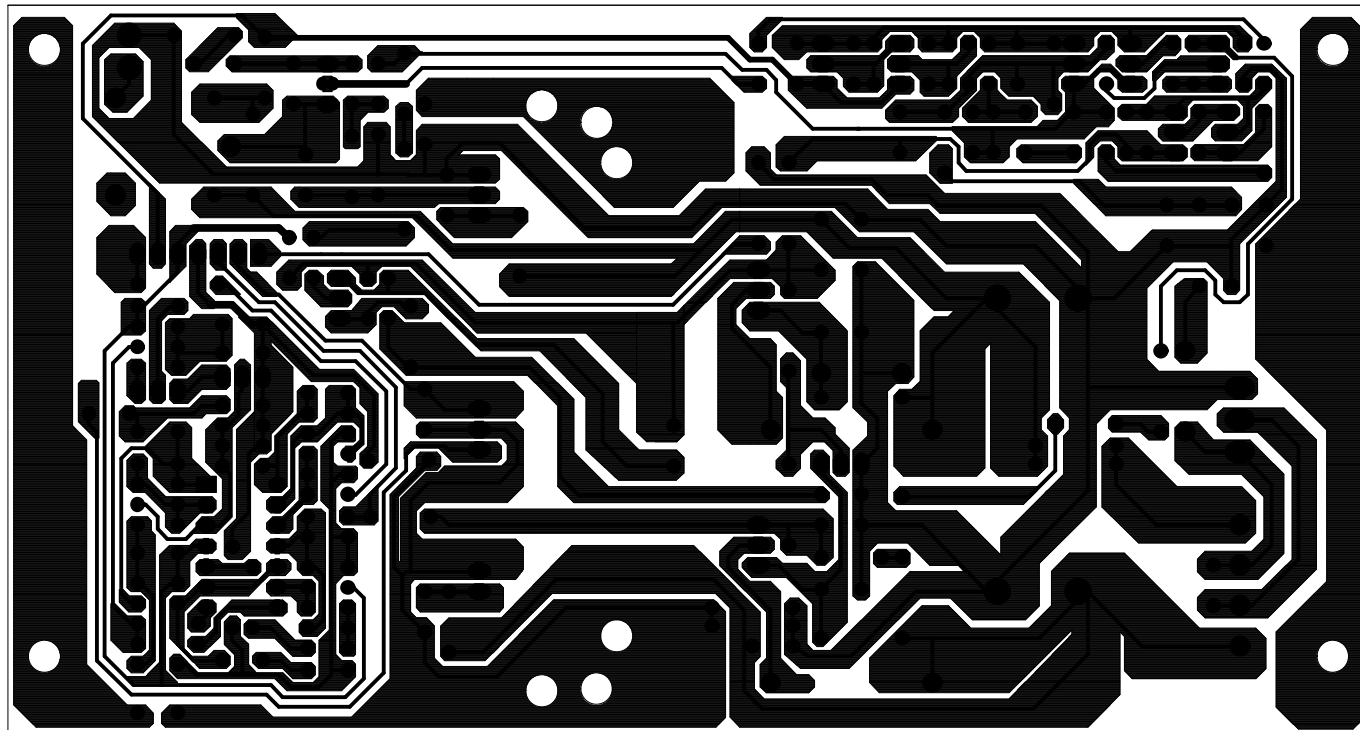

SUB-TS18 120V Electrical parts list			
Part number	Description	Qty	Reference Designator
PREAMP PCB			
<i>Resistors</i>			
110-12472j52-e	RESISTOR 4.7K 1/2W ±5% CF 52mm (RoHS)	2	R201,R202
110-16102j26-e	RESISTOR 1K 1/6W ±5% CF 26mm (RoHS)	6	R213,R214,R215,R254,R253,R304
110-16103j26-e	RESISTOR 10K 1/6W ±5% CF 26mm (RoHS)	18	R209,R212,R216,R217,R218,R220,R221,R222,R225,R228,R229,R230,R232,R235,R240,R248,R260,R270
110-16104j26-e	RESISTOR 100K 1/6W ±5% CF 26mm (RoHS)	5	R231,R263,R266,R257,R300
110-16105j26-e	RESISTOR 1M 1/6W ±5% CF 26mm (RoHS)	1	R259
110-16113j26-e	RESISTOR 11K 1/6W ±5% 26mm (RoHS)	1	R268
110-16122j26-e	RESISTOR 1.2K 1/6W ±5% CF 26mm (RoHS)	1	R265
110-16134j26-e	RESISTOR 130K 1/6W ±5% CF 26mm (RoHS)	1	R233
110-16152j26-e	RESISTOR 1.5K 1/6W ±5% CF 26mm (RoHS)	1	R302
110-16183j26-e	RESISTOR 18K 1/6W ±5% CF 26mm (RoHS)	1	R262
110-16203j26-e	RESISTOR 20K 1/6W ±5% CF 26mm (RoHS)	2	R237,R238
110-16223j26-e	RESISTOR 22K 1/6W ±5% CF 26mm (RoHS)	6	R247,R255,R256,R249,R250,R261
110-16303j26-e	RESISTOR 30K 1/6W ±5% CF 26mm (RoHS)	2	R223,R224
110-16472j26-e	RESISTOR 4.7K 1/6W ±5% CF 26mm (RoHS)	3	R200,R207,R258
110-16473j26-e	RESISTOR 47K 1/6W ±5% CF 26mm (RoHS)	2	R219,R264
110-16474j26-e	RESISTOR 470K 1/6W ±5% CF 26mm (RoHS)	1	R251
110-16475j26-e	RESISTOR 4.7M 1/6W ±5% CF 26mm (RoHS)	1	R303
110-16512j26-e	RESISTOR 5.1K 1/6W ±5% CF 26mm (RoHS)	2	R210,R211
110-16622j26-e	RESISTOR 6.2K 1/6W ±5% CF 26mm (RoHS)	1	R234
110-16684j26-e	RESISTOR 680K 1/6W CF 26mm (RoHS)	1	R252
110-16912j26-e	RESISTOR 9.1K 1/6W ±5% CF 26mm (RoHS)	2	R226,R227
110-16913j26-e	RESISTOR 91K 1/6W ±5% CF 26mm (RoHS)	4	R203,R204,R205,R206
116-169091f26-e	RESISTOR 9.09K 1/6W±1% MF 26mm (RoHS)	1	R301
115-h503a102-e	variable RESISTOR RV16AE-20B2-15K-A54-104(A50K) (RoHS)	1	VR201
116-201001j5vx-e	metal oxide film RESISTOR 1K 2W ±5% 5mm (RoHS)	1	R267
<i>Capacitors</i>			
129-a154j633-e	METALIZE CAP. 0.15U 63V ±5% MSC (RoHS)	2	C221,C222
129-a224j633-e	METALIZE CAP. 0.22uF 63V ±5% MSC (RoHS)	1	C218
130-2b103k503-e	DISC CAPACITOR 0.01u 50V ±10% (RoHS)	1	C238
130-2b221k503-e	DISC CAPACITOR 220P 50V ±10% (RoHS)	12	C200,C204,C205,C207,C208,C210,C211,C212,C214,C220,C230,C237
130-3f104z503-e	DISC CAPACITOR 0.1U 50V +80/-20% (RoHS)	8	C232,C242,C244,C245,C246,C252,C254,C256
132-183j503-e	MYLAR CAPACITOR 0.018uF 50V ±5% (RoHS)	1	C223
132-223ja03-e	MYLAR CAPACITOR 0.022uF 100V ±5% (RoHS)	1	C215
132-473j503-e	MYLAR CAPACITOR 0.047U 50V ±5% (RoHS)	1	C224
132-563j503-e	MYLAR CAPACITOR 0.056U 50V ±5% (RoHS)	1	C216
132-823j503-e	MYLAR CAPACITOR 0.082U 50V ±5% (RoHS)	1	C217
135-3105m50-e	ELECTROLYTIC CAP. 1U 50V ±20% (RoHS)	1	C228
135-3106m50-e	ELECTROLYTIC CAP. 10uF 50V ±20% (RoHS)	12	C201,C202,C206,C213,C219,C231,C241,C243,C251,C253,C248,C247
135-3107m16-e	ELECTROLYTIC CAP. 100uF 16V ±20% (RoHS)	1	C234
135-3226m50-e	ELECTROLYTIC CAP. 22U 50V ±20% (RoHS)	1	C225
135-3475m16-e	ELECTROLYTIC CAP.4.7U 16V ±20% (RoHS)	1	C233
135-3107m50-e	ELECTROLYTIC CAP. 100U 50V ±20% (RoHS)	1	C301
135-3227m50-e	ELECTROLYTIC CAP. 220uF 50V ±20% (RoHS)	1	C300
<i>Semiconductors</i>			
192-027c1815gr-e	TRANSISTOR 2SC1815GR NPN TOSHIBA(RoHS)	4	Q201,Q206,Q207,Q208
197-631n4148-e	DIODE 500mW 75V 1N4148 Panjit (RoHS)	13	D201,D202,D203,D204,D205,D206,D207,D208,D214,D215,D216,D301,D302
199-65000513g-e	ZENER DIODE GDZJ5.1B 500mW 5.1V 2% ROHM 1N5231B	1	D213
190-06m4558d-e	I.C. OPA 4558D dual OP-AMP inline (RoHS)	1	U203
190-06m4558ld-e	I.C. NJRC NJM4558LD OP-AMP inglerow inline (RoHS)	1	U204
190-16t074cn-e	I.C TL074CN ST QUAD OP-AMP	2	U201,U202
197-141n4004-e	*DIODE 1N4004 shaping short crus (RoHS)	4	D217,D218,D219,D220
190-05ps25051-e	photoelectric coupler PS2505-1 NEC (RoHS)	1	U1

Part number	Description	Qty	Reference Designator
PREAMP PCB			
<i>Miscellaneous</i>			
162-50122004-e	drop-out line 120mm RED/WHT 2PIN (RoHS)	1	D209
162-5014d008-e	WIRE 2468#26AWG RED/WHT length 140mm (RoHS)	1	P1-P2
162-a016d001-e	mixed wire UL1007 160/80mm#26 (RoHS)	1	W202
174-0rca313v-e	RCA JACK RCA-313G V/R/W (RoHS)	1	JK201
174-20810360g-e	jack SPK JK BP 8PIN (RoHS) SH0810360G US1.35	1	JK202
174-6ej3556agp-e	PHONE JACK EJ3556A-GP (RoHS)	1	JK203
175-1b08v01-e	WIRE CONNECTOR & BASE 8 PIN PITCH=2.0mm(RoHS)	1	W202
175-1c07v01-e	WIRE CONNECTOR & BASE 7PIN PITCH=2.5mm (RoHS)	1	M201
180-tms7210v-e	SWITCH SLIDE 6PIN MS7210V (RoHS)	3	SW201,SW202,SW203
362-FE-00041-0LAE	PCB support 11.75*8.5*12.5H (RoHS)	2	
MAIN PCB			
<i>Resistors</i>			
110-14103j26-e	RESISTOR 10K 1/4W ±5% CF 26mm (RoHS)	3	R503,R504,R510
110-14222j26-e	RESISTOR 2.2K 1/4W ±5% CF 26mm (RoHS)	1	R511
110-14432j26-e	RESISTOR 4.3K 1/4W ±5% CF 26mm (RoHS)	1	R506
110-14472j26-e	RESISTOR 4.7K 1/4W ±5% CF 26mm (RoHS)	1	R505
110-16102j26-e	RESISTOR 1K 1/6W ±5% CF 26mm (RoHS)	1	R153
110-16103j26-e	RESISTOR 10K 1/6W ±5% CF 26mm (RoHS)	10	R128,R130,R149,R150,R305,R306,R308,R311,R314,R319
110-16104j26-e	RESISTOR 100K 1/6W ±5% CF 26mm (RoHS)	3	R122,R126,R307
110-16153j26-e	RESISTOR 15K 1/6W ±5% CF 26mm (RoHS)	1	R107
110-16182j26-e	RESISTOR 1.8K 1/6W ±5% CF 26mm (RoHS)	1	R145
110-16203j26-e	RESISTOR 20K 1/6W ±5% CF 26mm (RoHS)	1	R309
110-16221j26-e	RESISTOR 220Ω 1/6W ±5% CF 26mm (RoHS)	1	R144
110-16222j26-e	RESISTOR 2.2K 1/6W ±5% CF 26mm (RoHS)	1	R102
110-16223j26-e	RESISTOR 22K 1/6W ±5% CF 26mm (RoHS)	1	R316
110-16333j26-e	RESISTOR 33K 1/6W ±5% CF 26mm (RoHS)	1	R310
110-16393j26-e	RESISTOR 39K 1/6W ±5% CF 26mm (RoHS)	1	R151
110-16434j26-e	RESISTOR 430K 1/6W ±5% CF 26mm (RoHS)	1	R312
110-16473j26-e	RESISTOR 47K 1/6W ±5% CF 26mm (RoHS)	2	R106,R129
110-16474j26-e	RESISTOR 470K 1/6W ±5% CF 26mm (RoHS)	1	R127
110-16562j26-e	RESISTOR 5.6K 1/6W ±5% CF 26mm (RoHS)	1	R152
110-16621j26-e	RESISTOR 620Ω 1/6W ±5% CF 26mm (RoHS)	1	R160
110-16751j26-e	RESISTOR 750Ω 1/6W ±5% CF 26mm (RoHS)	1	R315
110-16755j26-e	RESISTOR 7.5M 1/6W ±5% CF 26mm (RoHS)	1	R313
116-161002f26-e	metal film RESISTOR 10K 1/6W ±1% MF 26mm (RoHS)	2	R301,R303
116-161202f26-e	metal film RESISTOR 12.0K 1/6W ±1% MF 26mm (RoHS)	1	R302
116-162200f26-e	metal film RESISTOR 220Ω 1/6W ±1% MF 26mm (RoHS)	1	R317
116-162202f26-e	metal film RESISTOR 22.0K 1/6W ±1% MF 26mm (RoHS)	1	R318
110-20332jk3-e	RESISTOR 3.3K 2W ±5% standing short crus 7.5m (RoHS)	1	R134
113-50s68j00-e	cement RESISTOR 0.068Ω 5W ±5% prone long crus (RoHS)	1	R147
116-201001jk3x-e	oxide film RESISTOR 1.00K 2W ±5% 7.5mm (RoHS)	1	R148
116-304700jk2x-e	oxide film RESISTOR 470Ω 3W ±5% 10mm (RoHS)	2	R501,R502
<i>Capacitors</i>			
130-3f104z503-e	DISC CAPACITOR 0.1U 50V +80/-20% (RoHS)	6	C107,C117,C122,C144,C320,C322
130-sl101k503-e	DISC CAPACITOR 100P 50V SL ±10% (RoHS)	3	C302,C303,C306
132-103j503-e	MYLAR CAPACITOR 0.01uF 50V ±5% (RoHS)	2	C305,C317
132-103ja03-e	MYLAR CAPACITOR 0.01uf 100V ±5% (RoHS)	2	C103,C104
132-104ja03-e	MYLAR CAPACITOR 0.1UF 100V ±5% (RoHS)	3	C123,C503,C504
132-273ja03-e	MYLAR CAPACITOR 0.027UF 100V ±5% (RoHS)	1	C143
135-3106m50-e	ELECTROLYTIC CAP. 10uF 50V ±20% (RoHS)	2	C319,C321
135-3107m10-e	ELECTROLYTIC CAP. 100U 10V ±20% (RoHS)	2	C114,C115
135-3107m35-e	ELECTROLYTIC CAP. 100U 35V ±20% (RoHS)	2	C507,C508
135-3225m50-e	ELECTROLYTIC CAP. 2.2U 50V ±20% (RoHS)	1	C509
135-3226m16-e	ELECTROLYTIC CAP. 22U 16V ±20% (RoHS)	1	C304
135-3226m50-e	ELECTROLYTIC CAP. 22U 50V ±20% (RoHS)	2	C505,C506
135-3227m16-e	ELECTROLYTIC CAP. 220U 16V ±20% (RoHS)	1	C118
135-3476m16-e	ELECTROLYTIC CAP. 47U 16V ±20% (RoHS)	1	C318

Part number	Description	Qty	Reference Designator
MAIN PCB			
138-5478m80-e	LARGE ELECTROLYTIC CAP. 4700uF 80V ±20% 85 °C	2	C501,C502
132-103kd00-e	MYLAR CAPACITOR 0.01U 400V +/-10% long crus (RoHS)	1	C500
<i>Semiconductors</i>			
192-027c1815gr-e	TRANSISTOR 2SC1815GR NPN TOSHIBA(RoHS)	5	Q108,Q109,Q113,Q301,Q302
192-027c2235y-e	TRANSISTOR 2SC2235Y NPN TOSHIBA (RoHS)	1	Q111
192-028a1015gr-e	TRANSISTOR 2SA1015GR PNP TOSHIBA(RoHS)	3	Q101,Q107,Q112
192-1572n5551-e	*TRANSISTOR FSC 2N5551 NPN (RoHS)	2	Q114,Q115
192-1582n5401-e	TRANSISTOR FSC 2N5401 AI-PNP 350V 500mA TO-92 (RoHS)	1	Q503
197-631n4148-e	DIODE 500mW 75V 1N4148 Panjit (RoHS)	7	D102,D103,D104,D105,D143,D301,D302
199-65000623g-e	ZENER DIODE GDZJ6.2B 500mW 6.2V 26mm 2% (RoHS)	1	D101
199-65001603g-e	ZENER DIODE GDZJ16C 500mW 16V 26mm 2% (RoHS)	1	D502
190-16t074cn-e	I.C TL074CN ST QUAD OP-AMP	1	U301
192-161tip31c-e	TRANSISTOR TIP31C NPN SGS (RoHS)	1	Q501
192-162tip32c-e	TRANSISTOR TIP32C PNP SGS (RoHS)	1	Q502
197-00kbu606g-e	bridge rectifier 6A 800V KBU606G (RoHS)	1	D501
197-141n4004-e	*DIODE 1N4004 shaping short crus (RoHS)	2	D110,D504
<i>Miscellaneous</i>			
109-1ttc802j0-e	thermistor TTC-802(JS) NTC long crus (RoHS)	1	TH1
120-1000003-e	inductor 10W AI YT-C3104-005 1CRHW 354708LTB (RoHS)	2	FB1,FB2
162-50129001-e	CABLE ASS'Y drop-out line 120mm AWG28 WHT (RoHS)	1	W201
171-urwh124d-e	relay RWH-SH-124D (1600 ohm) (RoHS)	1	RL1
175-1d02v01-e	WIRE CONNECTOR & BASE 2PIN PITCH=3.96mm (RoHS)	1	M100
175-1d03v01-e	WIRE CONNECTOR & BASE 3 PIN PITCH=3.96mm JST-VH take off the middle PIN	1	M500
CLASS D ASS'Y PCB (Replacment of entire module is recommended, part# 051-B00012A-E).			
<i>Resistors</i>			
118-12061001j-e	SMD RESISTOR 1.00K 1206 5% (RoHS)	4	R2,R11,R29,R30
118-12061002j-e	SMD RESISTOR 10.0K 1206 5% (RoHS)	3	R7,R9,R25
118-120610r0j-e	SMD RESISTOR 10.0Ω 1206 5% (RoHS)	2	R22,R23
118-12061201j-e	SMD RESISTOR 1.20K 1206 5% (RoHS)	16	R31,R32,R33,R34,R35,R36,R37,R38,R39,R40,R41,R42,R43,R44,R45,R46
118-12062002j-e	SMD RESISTOR 20.0K 1206 5% (RoHS)	1	R26
118-12062201j-e	SMD RESISTOR 2.20K 1206 5% (RoHS)	3	R6,R13,R16
118-12062701j-e	SMD RESISTOR 2.70K 1206 5% (RoHS)	1	R10
118-12063000j-e	SMD RESISTOR 300.0Ω 1206 5% (RoHS)	1	R24
118-12063301j-e	SMD RESISTOR 3.30K 1206 5% (RoHS)	4	R14,R15,R27,R28
118-12063902j-e	SMD RESISTOR 39.0K 1206 5% (RoHS)	1	R3
118-12064700j-e	SMD RESISTOR 470Ω 1206 5% (RoHS)	1	R8
118-12064701j-e	SMD RESISTOR 4.70K 1206 5% (RoHS)	3	R1,R5,R12
118-12064702j-e	SMD RESISTOR 47.0K 1206 5% (RoHS)	1	R17
118-12064704j-e	SMD RESISTOR 4.70M 1206 5% (RoHS)	1	R4
118-120647r0j-e	SMD RESISTOR 47.0Ω 1206 5% (RoHS)	2	R20,R21
<i>Capacitors</i>			
141-c0101k50-e	SMD CAPACITOR 100pF 50V 10% 1206 NPO (RoHS)	1	C4
141-c0220k50-e	SMD CAPACITOR 22pF 50V 10% 1206 SMT NPO (RoHS)	1	C5
141-c0561k50-e	SMD CAPACITOR 560pF 50V 10% 1206 NPO (RoHS)	1	C6
141-c5104m50-e	SMD CAPACITOR 1206 Y5V 0.1uF 50V ±20% (RoHS)	8	C2,C3,C7,C8,C9,C10,C11,C15
141-c7223k50-e	SMD CAPACITOR 0.022uF 50V 10% 1206 X7R (RoHS)	1	C13
141-d7104ka0-e	SMD CAPACITOR 0.1uF 100V 10% 1210 X7R (RoHS)	1	C12
141-d7104kb5-e	SMD CAPACITOR 0.1uF 250V 10% 1210 X7R (RoHS)	5	C1,C18,C19,C20,C14
<i>Semiconductors</i>			
190-16t072dts-e	*SMD I.C. TL072CDT Dual Op-Amp SGS THOMSON (RoHS)	1	IC1
192-09124126qs-e	SMD TRANSISTOR 2SC2412K-T146Q/R ROHM (RoHS)	3	Q1,Q4,Q5

Part number	Description	Qty	Reference Designator
CLASS D ASS'Y PCB			
192-09139066rs-e	SMD TRANSISTOR 2SC3906K-T146R ROHM (RoHS)	2	Q2,Q8
192-09210376qs-e	SMD TRANSISTOR 2SA1037K-T146Q/R ROHM (RoHS)	2	Q7,Q9
192-09215146rs-e	SMD TRANSISTOR 2SA1514K-T146R ROHM (RoHS)	2	Q3,Q6
197-03rls4148s-e	*SMD DIODE RLS4148-TE11 ROHM (RoHS)	6	D1,D2,D3,D4,D5,D6
199-15000563s-e	SMD ZENER 5.6V 5% PHILIPS BZX84-C5V6 (RoHS)	2	Z1,Z2
199-1500120s-e	SMD ZENER 12V 5% PHILIPS BZX84-C12 (RoHS)	2	Z5,Z6
199-15001503s-e	SMD ZENER 15V 5% PHILIPS BZX84-C15 (RoHS)	2	Z3,Z4
192-233f640n-e	TRANSISTOR IRF640N INTERNATIONAL (RoHS)	1	Q11
192-232irf9640-e	FET IRF9640 IR P-CH TO220 (RoHS)	1	Q10
<i>Miscellaneous</i>			
122-14350j4180-e	choke coil 35uH Ferrite Core 25 Milliohm (RoHS)	1	L2
128-e106ma01k-e	non polarized ELEC LYTIC CAP. 10UF 100V 20% 105 °C (RoHS)	2	C16,C17
175-9f40hr2-e	WIRE CONNECTOR & BASE 40PIN PITCH=2.54mm HR2*40 (RoHS)		
122-14121m4191-e	Ferrite core word type LS-A6206-ST EFD-30 (RoHS)	1	L1
MISCELLANEOUS/MECHANICAL			
150-r4055903-e	Power transformer TT0900304490 (RoHS)	1	T501
152-u602015-e	power cord joint heteropolarity SVT FT-26FT bi-insul (RoHS)	1	
154-k31505t0-e	fuse 3.15A 250V 30mm UL/CSA/PSE (RoHS)	1	
155-63032i-e	fuse holder HTB-321 30mm UL/CSA (RoHS)	1	F501
162-10152001-e	WIRE UL1617 AWG22 150mm RED 6:6 (RoHS)	1	
162-5020d006-e	WIRE UL2468 200mm 2.5mmpitch RED/WHT (RoHS)	1	
162-50552003-e	WIRE UL1007 #16 550mm (RoHS) #110/#205 0.5T	1	
176-wjce1-e	dead end CE-1 (RoHS)	1	
180-prf1003s-e	power switch ROCK RF-1003-BB2-OHA(RoHS)	1	SW501
193-201815t2-e	ceramic insulator (RoHS)	2	for Q10,Q11
302-AL-00373-1BGE	aluminium rear board 270*215*2.5T anode black (RoHS)	1	
306-ABS-00714-0BAE	plastic rear housing 268*213*102 spout conductive paint (RoHS)	1	
311-ABS-00028-0BAE	plastic KNOB 46077-W soft material P.V.C.(RoHS) LEVEL	1	
317-000-00037-0LAE	earth terminal M3 lug plate t=0.3 (RoHS)	1	
323-AL-00056-0LAE	heat sink 83.5*50.5*27.5H defat	1	
333-EVA-00096-0BAE	Gasket pad wide sides 213*15*2.0mm (RoHS)	2	
333-EVA-00097-0BAE	Gasket pad wide sides 213*15*1.0t (RoHS)	2	
333-EVA-00121-0BAE	8PIN BB Gasket (RoHS)	1	
333-EVA-00132-0BAE	Gasket pad long sides 238*15*2.0mm (RoHS)	2	
333-EVA-00133-0BAE	Gasket pad long sides 238*15*1.0t (RoHS)	2	
333-EVA-00188-0BAE	Gasket pad 170x5x1t glue on back (RoHS)	1	
333-EVA-00219-0BAE	Gasket pad wide sides 150*15*1t UL (RoHS)	2	
333-EVA-00220-0BAE	Gasket pad long sides 225*15*1t UL (RoHS)	1	
333-EVA-00866-0BAE	Gasket 48*18*1.5T (RoHS)	1	
335-NYL-00002-0BAE	WIRE CLIP 4K-4 NO-BB(RoHS)	1	
335-NYL-05015-0BAE	power cord fixed button SB4F-2 黑色(RoHS)	1	
350-EM04012D024-E	4*12 wood screw electrical back (RoHS)	4	
351-AM03008A078-E	M3*8 machine screw nickel plating (RoHS)	4	
351-AM03008A079-E	M3*8 machine screw electrical back (RoHS)	4	
352-AM03008D040-E	3*8 type ping screw electrical back (RoHS)	2	
352-AM03008D041-E	3*8 type ping screw nickel plating (RoHS)	2	
352-AM03010D065-E	3*10 P type ping electrical back (RoHS)	3	
352-HM03012D086-E	3*12 type ping screw electrical back (RoHS)	1	
353-0870122-E	machine screw M8*70 round head electrical back (RoHS)	1	
362-FE-00013-0LAE	PCB support L TYPE t=1.6mm S.P.C.C 89*9*1.6T (RoHS)	2	

Integrated Circuit Diagrams

TLO72, 4558 Dual Op Amp
IC1, U203

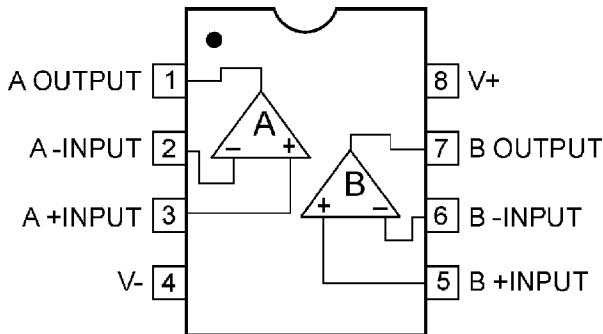

4558 Dual Op Amp U204

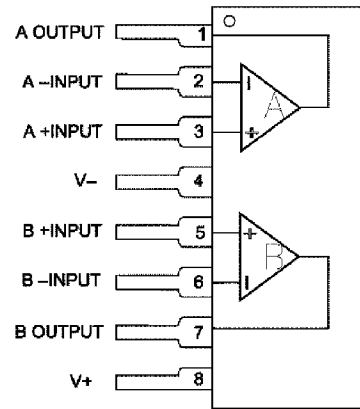

OPAMP, QUAD 14P DIL TL074
U201, 202, 301

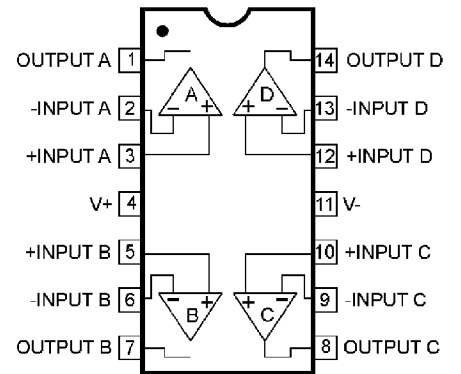

2N5401
Q503

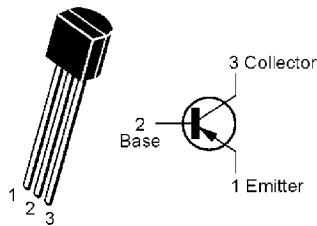

MOSFET
IRF640,
9640
Q10,11

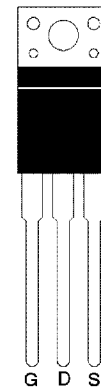

TIP 31C, 32C
Q501,502

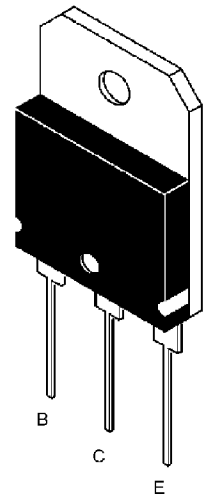

2SC2412K
2SC3906K
2SA1037K
2SA1514K

Q1 - Q9

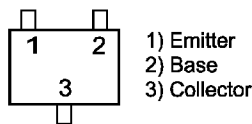

PS2505-1 U1

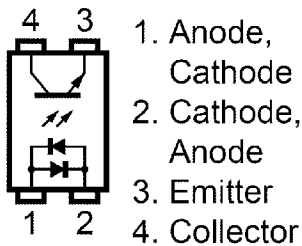

2SA1015
Q101,107,112

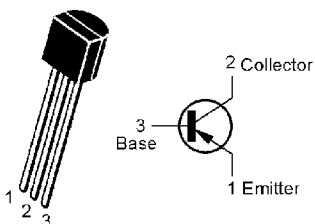

2N5551
Q114,115

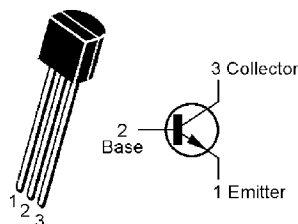

2SC2235Y
Q111

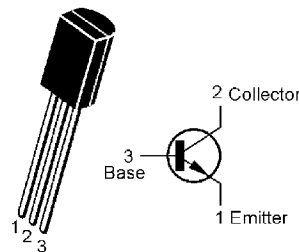

2SC1815
Q108,109,113,201,
206,207,208,301,302

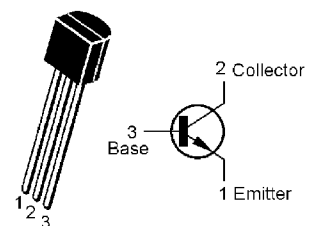

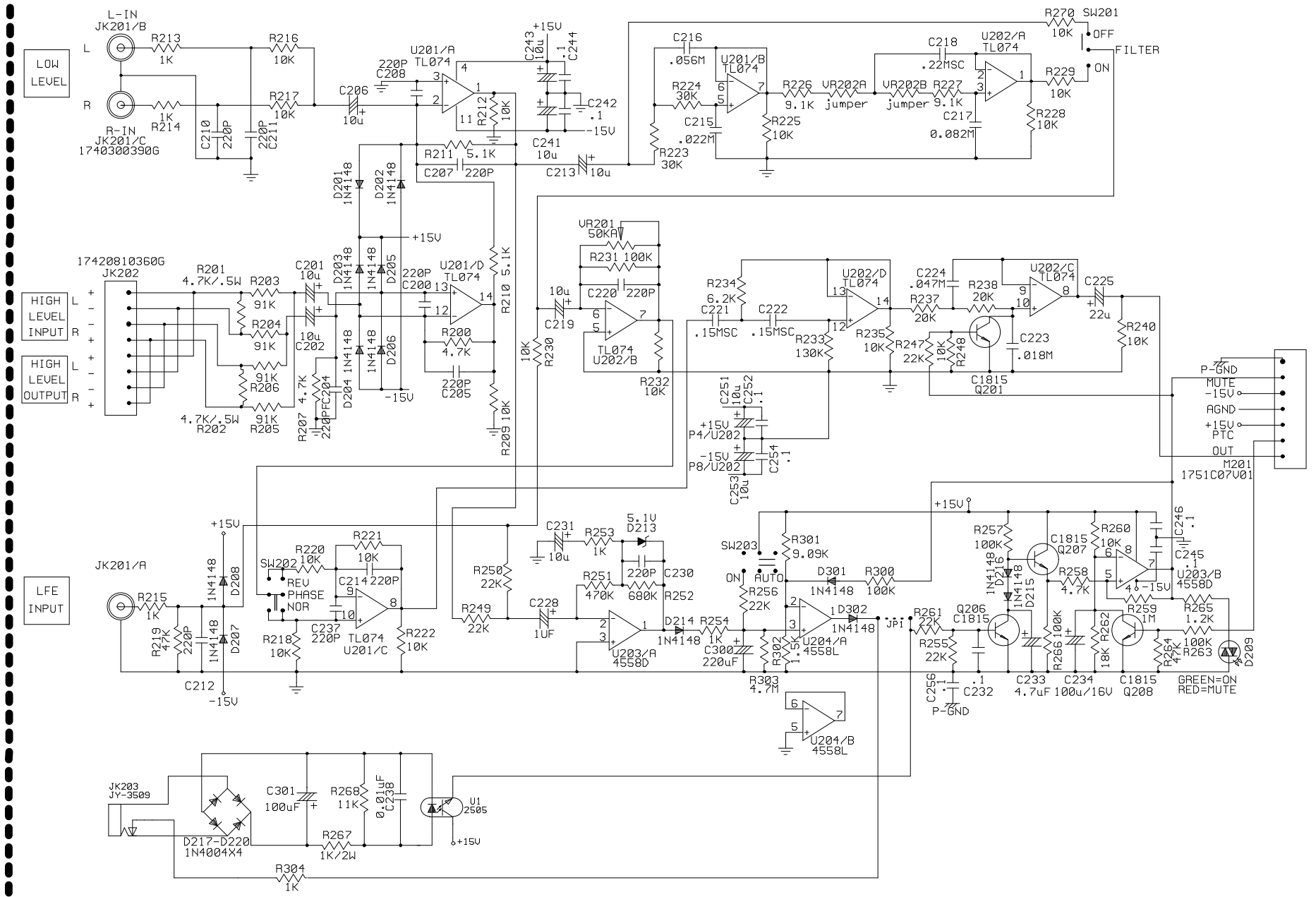

HKTS18E:
JACK PANEL PCB

APPROVE BY	CHECK BY	DRAWING BY	NAME: PRE-AMP	1 / 2
			MODEL: HKTS18	REV: A0
			CUSTOMER: HARMAN/KARDON	
			DATE: 2006.9.20	

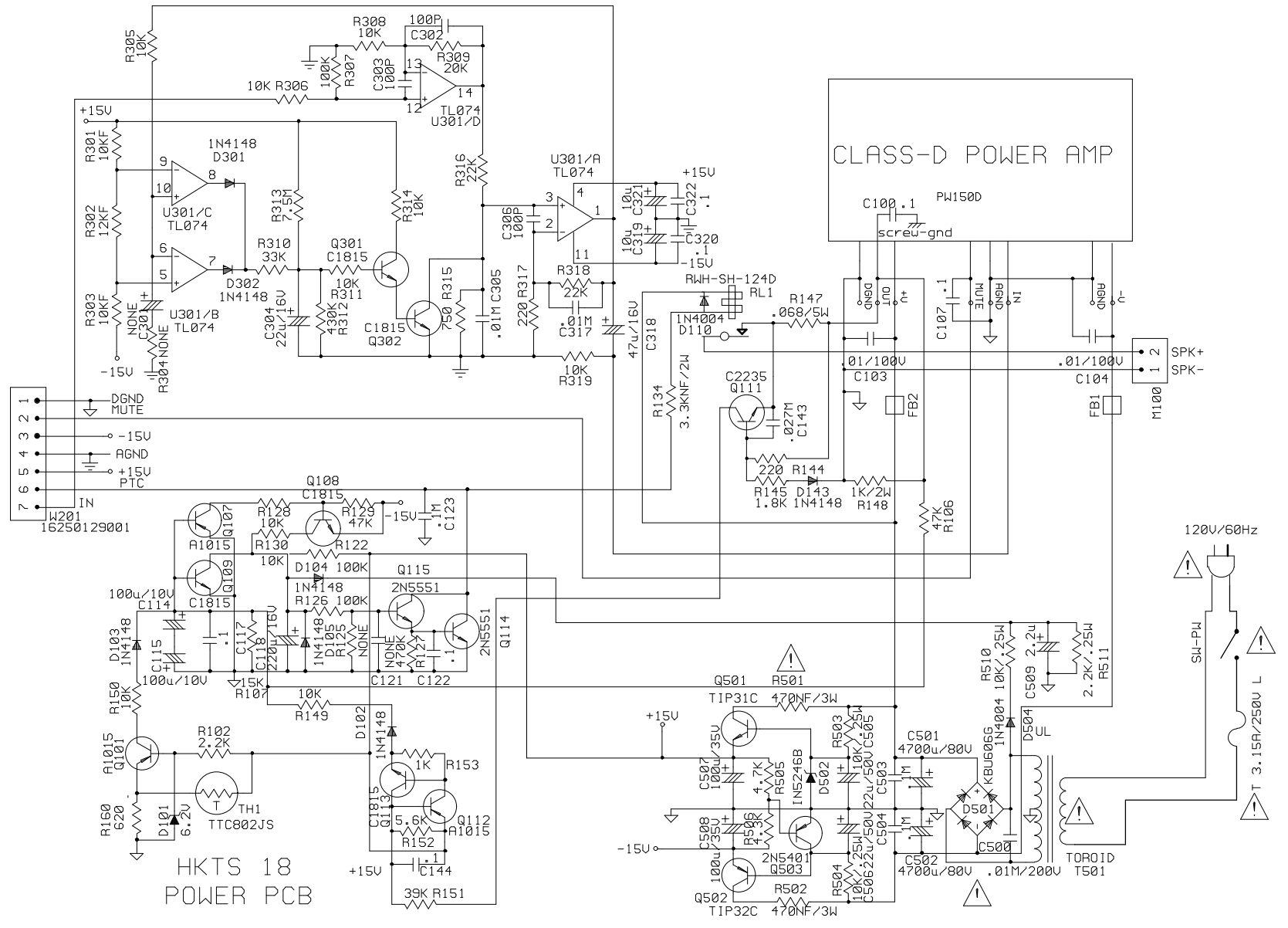

HKTS 18
POWER PCB

APPROVE BY	CHECK BY	DRAWING BY	NAME: POWER-AMP&LIMIT	2 / 2
			MODEL: HKTS18	REV:A0
			CUSTOMER: HARMAN/KARDON	
			DATE: 2006.9.20	

