

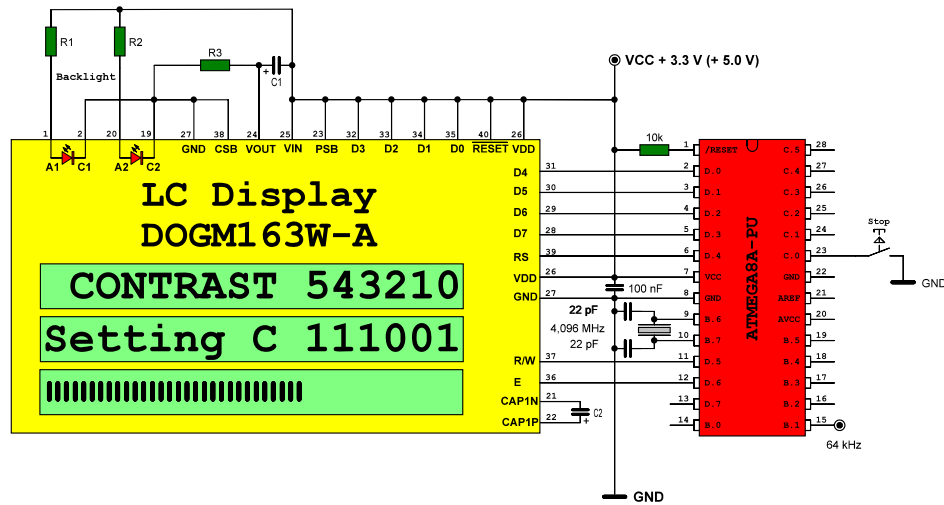

Wiring: 4 Bit

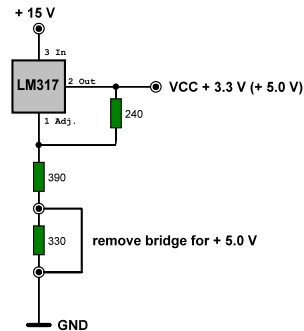

Wiring: SPI

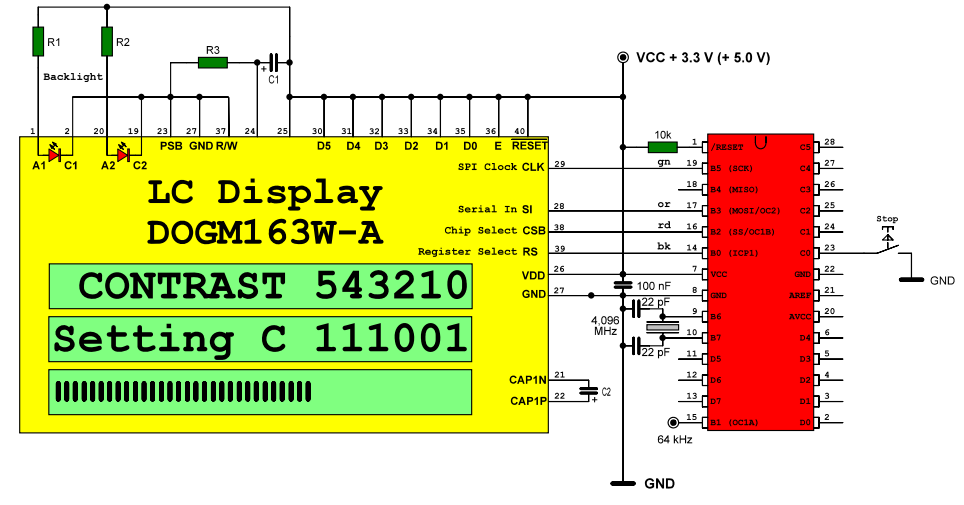

- R1 and R2 for the white backlight LED55X31-W: 330 Ohm
- R1 and R2 for the yellow backlight LED55X31-G: 15 Ohm
- R3 for DOGM162W-A 3.3 V: 68 k (for my device)
- R3 for DOGM163W-A 3.3 V: 12 k (for my device)
- R3 decreases the charge pump output voltage at LCD pin 24 to appr. + 5.0 V
- C1 and C2 for supply voltage 3.3 V: 1 µF
- C1 and C2 for supply voltage 5.0 V: None
- Supply voltage 5.0 V: Connect LCD pin 24 to + 5.0 V, leave pins 21 and 22 open
- Wiring of DOGM162W-A: No difference to DOGM163W-A

Datei: DOGM162_163 Modell	Kunde: DOGM162 DOGM163 Modell	Datum:
Bem:	Gegenstand: LCD und MPU	06.06.2015
 Klaus D.	Maschine: 4WIRE und SPI Verdrahtung	Blatt:
	Zeichn.-Nr.:	von: