

Front view and mounting

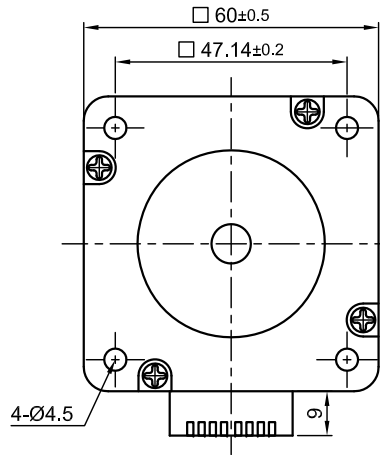

Side view

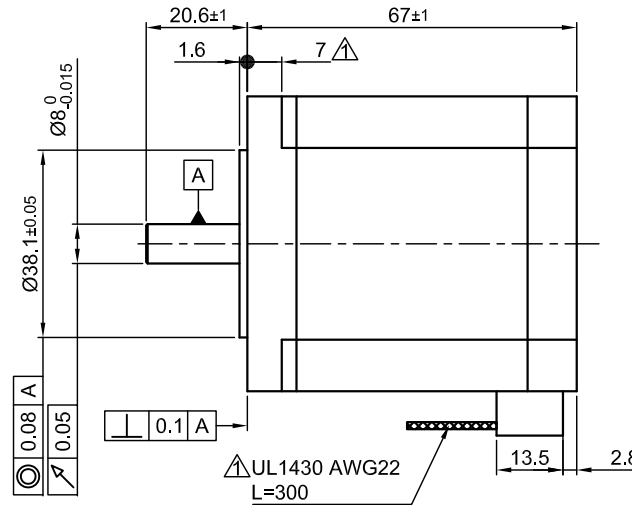

Rear view

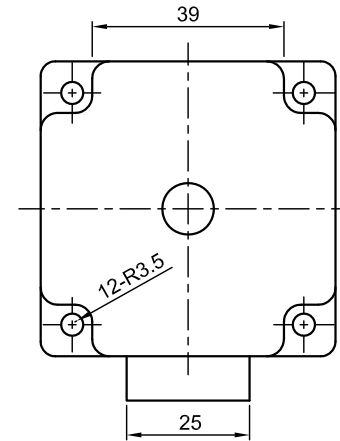

SPECIFICATION	CONNECTION	UNIPOLAR OR BIPOLAR-1 WINDING	BIPOLAR	
			SERIAL	PARALLEL
VOLTAGE (VDC)		4.8		
AMPS/PHASE		2.0	1.41	2.82
RESISTANCE/PHASE (Ohms)@25°C		2.4±15%	4.8±15%	1.2±15%
INDUCTANCE/PHASE (mH) @1KHz		4.6±20%	18.4±20%	4.6±20%
HOLDING TORQUE (Nm) [lb-in]		1.5 [13.28]	2.12 [18.76]	2.12 [18.76]
DETENT TORQUE (Nm) [lb-in]		0.045 [0.398]		
STEP ANGLE (°) ± ACCURACY		1.8±5% (NON-ACCUM)		
BACK-EMF (V) (300 U/min)		34.5		
ROTOR INERTIA (Kg-m ²) [lb-in ²]		5.7x10 ⁻⁵ [0.195]		
WEIGHT (Kg) [lb]		1.2 [2.646]		
TEMPERATURE RISE: MAX.80°C (MOTOR STANDSTILL; FOR 2 PHASE ENERGIZED)				
AMBIENT TEMPERATURE -10~ 50°C [14°F ~ 122°F]				
INSULATION RESISTANCE 100 MOhm (UNDER NORMAL TEMPERATURE AND HUMIDITY)				
INSULATION CLASS B 130° [266°F]				
DIELECTRIC STRENGTH 500VAC FOR 1 MIN. (BETWEEN THE MOTOR COILS AND THE MOTOR CASE)				
AMBIENT HUMIDITY MAX. 85% (NO CONDENSATION)				

PERMISSIBLE RADIAL+AXIAL FORCE				
ROTOR SPRING-MOUNTED IN AXIAL DIRECTION				
AXIAL-FORCE Fa (N)		Fa=14		
DISTANCE a (mm)		5	10	15
RADIAL-FORCE Fr (N)		163	112	85
		AXIAL	RADIAL	
SHAFT PLAY (mm)		0.075		0.025
AT LOAD MAX: (N)		10		5.0

TYPE OF CONNECTION (EXTERN)				MOTOR	
UNIPOLAR	BIPOLAR			LEADS	WINDING
	1WINDING	SERIAL	PARALLEL		
A	A	A	A	BLU/WHT	A
COM				BLU	
A\	A\	A\	A\	RED/WHT	A\
B	B	B	B	RED	
COM				GRN/WHT	B
B\	B\	B\	B\	GRN	
				BLK/WHT	B\
				BLK	

FULL STEP 2 PHASE-Ex., WHEN FACING MOUNTING END (X)

STEP	A	B	A\	B\	CCW	CW
1	+	+	-	-	↓	↑
2	-	+	+	-	↑	↓
3	-	-	+	+	↓	↑
4	+	-	-	+	↑	↓

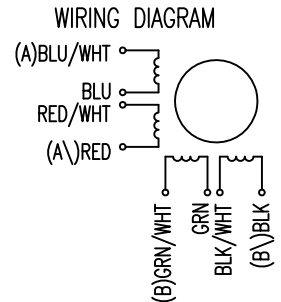

				 Nanotec [®] PLUG & DRIVE	SCALE FREE	APVD	<i>S.Ha.</i>	16.01.07	STEPPING MOTOR DWG.NO ST6018K2008-A
1	LENGTH+UL NO.	04.08.09	J.W.		X ±0.5	CHKD			
REV	DESCRIPTION	DATE	APVD	1PL ±0.2	DRN	<i>J.W.</i>	13.07.06		
				2PL ±0.1	SIGNATURE		DATE		
				ANGLE ±30'					