



TRM-868-EUR
RF Transceiver Module
Data Guide

Wireless made simple[®]

Warning: Some customers may want Linx radio frequency (“RF”) products to control machinery or devices remotely, including machinery or devices that can cause death, bodily injuries, and/or property damage if improperly or inadvertently triggered, particularly in industrial settings or other applications implicating life-safety concerns (“Life and Property Safety Situations”).

NO OEM LINX REMOTE CONTROL OR FUNCTION MODULE SHOULD EVER BE USED IN LIFE AND PROPERTY SAFETY SITUATIONS. No OEM Linx Remote Control or Function Module should be modified for Life and Property Safety Situations. Such modification cannot provide sufficient safety and will void the product’s regulatory certification and warranty.

Customers may use our (non-Function) Modules, Antenna and Connectors as part of other systems in Life Safety Situations, but only with necessary and industry appropriate redundancies and in compliance with applicable safety standards, including without limitation, ANSI and NFPA standards. It is solely the responsibility of any Linx customer who uses one or more of these products to incorporate appropriate redundancies and safety standards for the Life and Property Safety Situation application.

Do not use this or any Linx product to trigger an action directly from the data line or RSSI lines without a protocol or encoder/decoder to validate the data. Without validation, any signal from another unrelated transmitter in the environment received by the module could inadvertently trigger the action.

All RF products are susceptible to RF interference that can prevent communication. RF products without frequency agility or hopping implemented are more subject to interference. This module does not have a frequency hopping protocol built in.

Do not use any Linx product over the limits in this data guide. Excessive voltage or extended operation at the maximum voltage could cause product failure. Exceeding the reflow temperature profile could cause product failure which is not immediately evident.

Do not make any physical or electrical modifications to any Linx product. This will void the warranty and regulatory and UL certifications and may cause product failure which is not immediately evident.

Table of Contents

1	Description
2	Ordering Information
2	Absolute Maximum Ratings
3	Electrical Specifications
5	Pin Assignments
5	Pin Descriptions
6	Theory of Operation
7	Module Description
8	Digital Transmission System (DTS)
9	Protocol
11	Reset to Factory Default
11	Hardware Reset
11	Voltage Supply Rise Time
11	The $\overline{\text{CMD}}$ Line
12	The UART Interface
12	Configuration Command Formatting
14	Configuration Registers
16	Writing to Registers
16	Reading from Registers
18	Configuration Registers
29	Typical Applications
30	Power Supply Requirements
30	Antenna Considerations
31	Helpful Application Notes from Linx
32	Interference Considerations
33	Pad Layout
33	Board Layout Guidelines
35	Microstrip Details
36	Production Guidelines

- 36 [Hand Assembly](#)
- 36 [Automated Assembly](#)
- 38 [General Antenna Rules](#)
- 40 [Common Antenna Styles](#)
- 42 [Regulatory Considerations](#)

TRM-868-EUR RF Transceiver Module Data Guide



Description

The TRM-868-EUR combines a state-of-the-art low power wireless transceiver with a powerful multipoint-to-multipoint protocol controller to form a complete wireless communication solution capable of replacing wires in almost any RS-232/422/485 application. With a 115dB link budget and very low power operation modes, the DTS Series is excellent for AMR, RFID, Home Automation, and any other application requiring long range (1 mile / 1.6km line of sight) and long battery life.

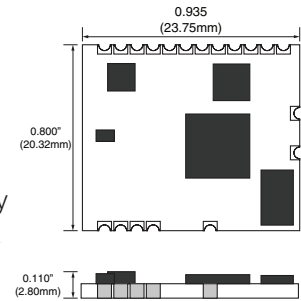

Figure 1: Package Dimensions

Features

- True UART to antenna solution
- 16-bit CRC error checking
- 76.8kbps max RF data rate
- 2 channels in DTS mode
- 6 channels in LP mode
- Small size – 0.8" x 0.935" (20.32 x 23.75mm)
- Low power Standby and Sleep modes
- Includes PHY and MAC protocol
- CSMA medium access control
- 115dB link budget in DTS mode
- 4 modes allow user to optimize power/range
- Command mode for volatile and non-volatile configuration
- 48-bit unique address
- 5 volt tolerant I/O
- 915MHz U.S. version available

Applications

- Direct RS-232/422/485 Wire replacement (requires external RS-232 to 3V CMOS conversion circuitry)
- Asset tracking
- Automated meter reading
- Industrial and/or home automation
- RFID
- Wireless sensors
- Remote data logging
- Fleet management



A large-print version of this document is available at www.linxtechnologies.com.

Ordering Information

Ordering Information		
Part Number	Description	Radiotronics Cross
TRM-868-EUR	868MHz EUR Series Transceiver	WI.232EUR
TRM-915-DTS	900MHz DTS Series Transceiver	Wi.232DTS-R
TRM-915-DTS-BRZ	900MHz DTS Series Transceiver - Brazil Channels	Wi.232DTSB-R

Transceivers are supplied in trays of 50 pieces

Figure 2: Ordering Information

Absolute Maximum Ratings

Absolute Maximum Ratings				
Supply Voltage V_{cc}	-0.3	to	+3.6	VDC
Any Input or Output Pin	-0.3	to	5.0	VDC
Supply Voltage Rise Time			1	ms
RF Input		15		dBm
Operating Temperature	-40	to	+85	°C
Storage Temperature	-40	to	+85	°C

Exceeding any of the limits of this section may lead to permanent damage to the device. Furthermore, extended operation at these maximum ratings may reduce the life of this device.

Figure 3: Absolute Maximum Ratings



Warning: This product incorporates numerous static-sensitive components. Always wear an ESD wrist strap and observe proper ESD handling procedures when working with this device. Failure to observe this precaution may result in module damage or failure.

Electrical Specifications

EUR Series Transceiver Specifications						
Parameter	Symbol	Min.	Typ.	Max.	Units	Notes
Power Supply						
Operating Voltage	V_{cc}	2.7	3.0	3.6	VDC	
TX Supply Current	I_{CCTX}					1,2,5
Low Power			24-32		mA	
Mid-Low Power			28-36		mA	
Mid-High Power			35-43		mA	
High Power			50-58		mA	
RX Supply Current	I_{CCRX}		16-24		mA	1,3
Standby Current	I_{STD}		850		μ A	1
Sleep Current	I_{FDN}		35	100	μ A	1
RF Section						
Operating Frequency Band	F_c	868.225		869.885	MHz	
Center Frequency Accuracy			2	3	PPM	
Number of Channels						
DTS Mode		2				
LP Mode		6				
Channel Spacing						
DTS Mode		650			kHz	
LP Mode		Variable			kHz	
Antenna Port						
RF Impedance	R_{IN}		50		Ω	
Environmental						
Operating Temp. Range		-40		+85	°C	
Receiver Section						
Receiver Sensitivity						
DTS Mode @ 2.4kbps			-106		dBm	
DTS Mode @115.2kbps			-102		dBm	
LP Mode @2.4kbps			-107		dBm	
LP Mode @9.6kbps			-104		dBm	
Input IP3			-40		dBm	4
LO Leakage			-65		dBm	5
Adjacent Channel Rejection			-48		dBc	6
IF Bandwidth						

EUR Series Transceiver Specifications						
Parameter	Symbol	Min.	Typ.	Max.	Units	Notes
DTS Mode			600		kHz	
LP Mode			200		kHz	
Transmitter Section						
Output Power	P_O		13	15	dBm	
Harmonic Emissions	P_H		-50		dBc	5
Frequency Deviation						
DTS Mode			±80		kHz	
LP Mode			±40		kHz	
Interface Section						
Input						
Logic Low	V_{IL}	0		$0.3 \cdot V_{CC}$	VDC	
Logic High	V_{IH}	$0.7 \cdot V_{CC}$		5.0	VDC	
Output						
Logic Low	V_{OL}	0		0.4	VDC	
Logic High	V_{OH}	2.5		V_{CC}	VDC	
Flash Specifications (Non-Volatile Registers)						
Flash Write Duration			16	21	ms	
Flash Write Cycles		20k	100k		cycles	
1.	$V_{CC} = 3.3VDC$		4.	$F_{LO} + 1MHz$ and $F_{LO} + 1.945MHz$		
2.	Varies with data rate		5.	Into a 50-ohm load		
3.	Continuous operation, varies with UART data rate		6.	$F_c \pm 650kHz$		

Figure 4: Electrical Specifications

Pin Assignments

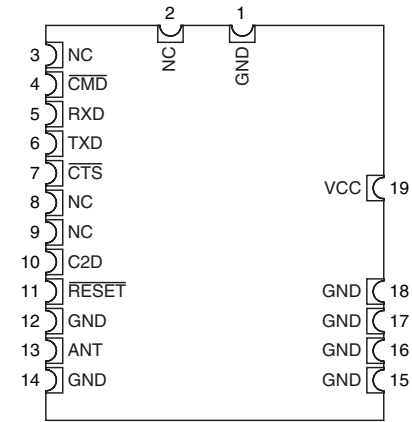

Figure 5: EUR Series Transceiver Pin Assignments (Top View)

Pin Descriptions

Pin Descriptions			
Pin Number	Name	I/O	Description
1, 12, 14, 15, 16, 17, 18	GND	—	Ground
2, 3, 8, 9	NC	—	No Electrical Connection. Do not connect any traces to these lines.
4	\overline{CMD}	I	Command Input. This line sets the serial data as either command data to configure the module or packet data to be sent over the air. Pull low for command data; pull high for packet data.
5	RXD	I	UART Receive Data Input. This is the input line for the configuration commands as well as data to be sent over the air.
6	TXD	O	UART Transmit Data Output. This is the output line for the configuration command responses as well as the data received over the air.
7	\overline{CTS}	O	UART Clear To Send, active low. This line indicates to the host microcontroller when the module is ready to accept data. When \overline{CTS} is high, the module is busy. When \overline{CTS} is low, the module is ready for data.
10	C2D	—	Reserved
11	\overline{RESET}	—	Reserved
13	ANT	—	50-ohm RF Antenna Port
19	VCC	—	Supply Voltage

Figure 6: EUR Series Transceiver Pin Descriptions

Theory of Operation

The EUR Series transceiver is a low-cost, high-performance synthesized FSK transceiver. Its wideband operation gives it outstanding range while still meeting regulatory requirements. Figure 7 shows a block diagram for the module.

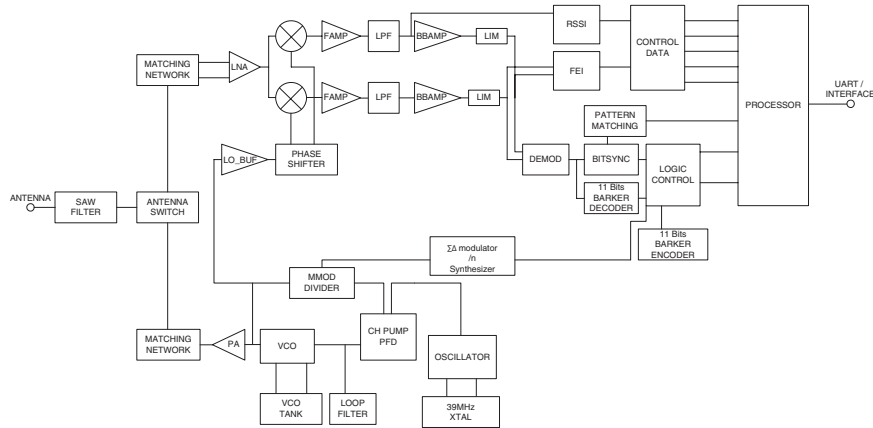

Figure 7: EUR Series Transceiver Block Diagram

The EUR Series transceiver is designed for operation in the 868 to 870MHz frequency band. The RF synthesizer contains a VCO and a low-noise fractional-N PLL. The receive and transmit synthesizers are integrated, enabling them to be automatically configured to achieve optimum phase noise, modulation quality and settling time.

The transmitter output power is programmable from -2dBm to $+15\text{dBm}$. The frequency deviation is optimized to deliver the highest performance over a wide range of data rates.

The receiver incorporates highly efficient low-noise amplifiers that provide up to -102dBm sensitivity.

An onboard controller performs the radio control and management functions. A processor performs the higher level protocol functions and controls the serial and hardware interfaces.

Module Description

The EUR Series RF transceiver module has a Universal Asynchronous Receiver Transmitter (UART) serial interface and is designed to create a complete UART-to-antenna wireless solution capable of direct wire replacement in most embedded RS-232/422/485 applications.

Note: Although the module is capable of supporting the serial data communications required by RS-232, RS-422, and RS-485 networks, it is not compatible with the electrical interfaces for these types of networks. The module has CMOS inputs and outputs and requires an appropriate converter for the particular type of network being used.

The module is designed to interface directly to a host UART. Three lines are used to transfer data between the module and the host UART: TXD, RXD and $\overline{\text{CTS}}$. TXD is the data output from the module. RXD is the data input to the module. The CTS output indicates if the module is ready to accept data. The UART interface is capable of operating in full duplex at baud rates from 2.4 to 115.2kbps.

The module has a built-in protocol that automatically transmits the data input on the UART. All encoding, transmitting, receiving and decoding functions are handled by the internal processor, so no overhead is required by an external processor.

The module can be put into a Sleep mode through serial commands. In Sleep mode, the RF section is completely shut down and the protocol processor is in an idle state. Once the module has been placed in the sleep mode, it can be awakened by sending a power-up sequence through the serial port.

If the current draw in sleep mode is too high for a particular application, the designer can switch power to the module through a FET to turn off the module when it is not needed. If this technique is used, the volatile registers reset to the values in their non-volatile mirrors, so any changes from the default will have to be reloaded.

Every module has a 48-bit MAC address that can be used by the host application to uniquely identify each module. This MAC address can be read through the command interface.

Digital Transmission System (DTS)

The EUR Series transceiver utilizes a DTS digital spread spectrum technique. This technique increases the transmission bandwidth to over 500kHz and the outgoing RF data is encoded with symbols selected to ensure its average duty cycle is 50%.

In DTS mode, the module's channel bandwidth is set to 600kHz and the transmit power is set to one of four selectable levels. In this mode, the module can operate on 2 channels and support a maximum RF data rate of 76.8kbps. The receiver sensitivity at the max data rate is -102dBm typical, yielding a link budget of 115dB. This mode is an excellent alternative to Frequency Hopping Spread Spectrum (FHSS). It has no synchronization requirements, allowing it to operate in a duty-cycle mode for extended battery life.

In low-power (LP) mode, the module's channel bandwidth is set to 200kHz and the transmit power is set to one of four selectable levels. In this mode, the module can operate on 6 channels and support a maximum data rate of 9.6kbps. The receiver sensitivity at the maximum data rate is -104dBm typical, yielding a link budget of 117dB. This mode reduces transmit current consumption, allowing use with batteries that cannot supply the pulse currents required for DTS mode.

DTS Systems have several advantages over FHSS and Direct Sequence Spread Spectrum (DSSS) systems. A DTS system operates on one RF channel at a time, so there is no interruption of the data transfer. FHSS systems have to stop sending data when they hop to a new channel. FHSS systems also have to synchronize the transmitter and receiver to make sure that they hop to the same channel at the same time. This synchronization can take 25ms or more while a DTS system can wake up in less than 10ms. Further, FCC regulations require that FHSS systems use each channel equally, so they frequently send null data just to use a channel. This increases current consumption, which is a disadvantage in battery operated devices.

DSSS systems also operate on one channel at a time, but their hardware implementations are much more expensive than a DTS system. Their channels are much wider which means that a DSSS receiver's sensitivity is much lower than a DTS system.

Both FHSS and DSSS systems can operate at higher power levels than

DTS systems, depending on the energy density of the DTS system. However, a DTS system is a good compromise between FHSS and DSSS.

Protocol

The built-in protocol has a number of features that make it a robust system. When the module has a packet to send, it uses a Carrier-Sense-Multiple-Access (CSMA) protocol to determine if another module is already transmitting. If so, the module receives that data before attempting to transmit its data again. If the UART receive buffer gets full, the $\overline{\text{CTS}}$ line goes high to prevent the host UART from over-running the receive buffer.

The CSMA mechanism introduces a variable delay to the transmission channel. This delay is the sum of a random period and a weighted period that is dependent on the number of times that the module has tried and failed to access the channel. For applications that guarantee that only one module is transmitting at any given time, the CSMA mechanism can be turned off to avoid this delay.

The module prefixes the data with a packet header and postfixes the data with a 16-bit CRC. The 16-bit CRC error checking can be disabled to allow the host application to do its own error checking. Data is encoded using a proprietary algorithm to spread the RF energy within the transmission bandwidth and meet regulatory requirements.

Each module can be assigned a 7-bit group ID, which is used to logically link it to other modules on the same channel. Any data received from a module with a different group ID is discarded.

Modules can also operate in two network modes: Master/Slave and Peer-to-Peer. These modes define a set of communication rules that identifies which modules can talk to any given module. In Master/Slave mode, masters can talk to slaves and other masters, slaves can talk to masters, but slaves cannot talk to other slaves. This mode is sometimes required for applications that are replacing legacy RS-485 networks. In peer-to-peer mode, any module can talk to any other module. In both modes, group integrity is enforced.

When a module transmits a packet, all other modules on the same channel receive the packet, check the packet for errors, determine whether the received group ID matches the local group ID, and compare the sender's master/slave flag to its internal setting. If the packet is error free, the group

IDs match, and the master/slave rules are satisfied (if peer to peer is selected in the receiving module, this test passes regardless), the module decodes the data and outputs it on the RXD line.

The primary state when the module is not actively transmitting or receiving data is the IDLE state. While in this state, the receiver is enabled and the module is continuously listening for incoming data. If the module detects a pre-amble and valid start-code, it enters the RX HEADER state. Figure 8 shows the receiver state diagram and Figure 9 shows the transmitter state diagram.

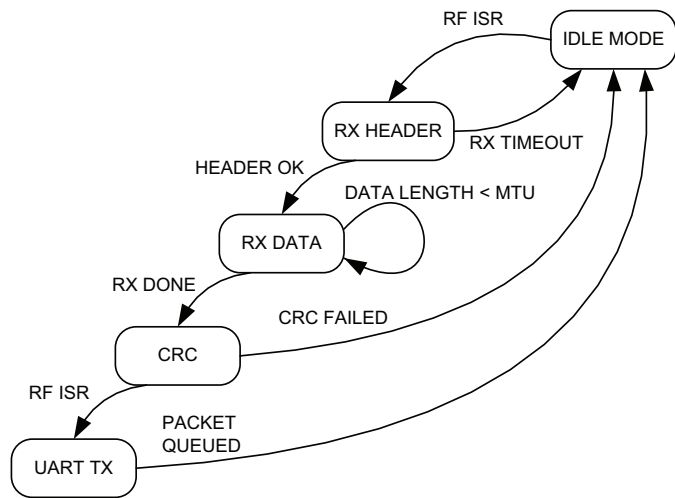

Figure 8: EUR Series Transceiver Receiver State Diagram

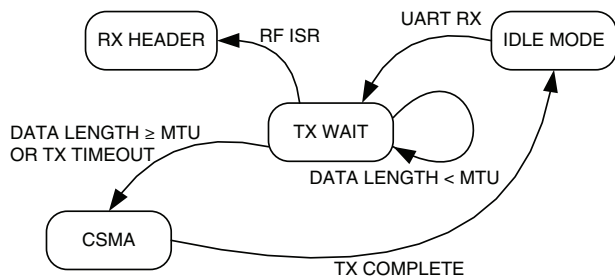

Figure 9: EUR Series Transceiver Transmitter State Diagram

Reset to Factory Default

It may be necessary to reset the non-volatile registers to their factory defaults. To reset the module, hold the $\overline{\text{CMD}}$ line low and cycle power to hardware-reset the module. The $\overline{\text{CMD}}$ line must remain low for a minimum of 600ms after resetting the module. Once the $\overline{\text{CMD}}$ line is released, the module's non-volatile registers are reset to factory defaults.

Hardware Reset

Pulling the $\overline{\text{RESET}}$ line low places the module's protocol controller in hardware reset. In this state, the module is in a safe, stalled state. If the voltage supply rise time is greater than 1ms, the module should be held in reset until V_{cc} reaches 2.7V. There are many reset supervisor ICs that can accomplish this task.

The $\overline{\text{RESET}}$ line must be held low for at least 20 μs to cause the module to enter reset. Normal operation is restored when this pin is returned high.

Voltage Supply Rise Time

The power supply rise time is extremely important. It must rise from ground to 2.7V in less than 1ms. If this specification cannot be met, an external reset supervisor circuit must be used to hold the module in reset until the power supply stabilizes. Failure to ensure adequate power supply rise time can result in loss of important module configuration information.

The $\overline{\text{CMD}}$ Line

The $\overline{\text{CMD}}$ line is used to inform the module where incoming UART data should be routed. When the line is high or left floating, all incoming UART data is treated as payload data and is routed to the transmitter to be sent over the air. If the $\overline{\text{CMD}}$ line is low, the incoming UART data is routed to the command parser for processing. Since the module's processor looks at UART data one byte at a time, the $\overline{\text{CMD}}$ line must be held low for the entire duration of the command plus a 20 μs margin for processing. Leaving the line low for additional time (for example, until the ACK byte is received by your application) does not adversely affect the module. If RF packets are received while the $\overline{\text{CMD}}$ line is active, they are still processed and output on the module's UART. Figure 10 shows this timing.

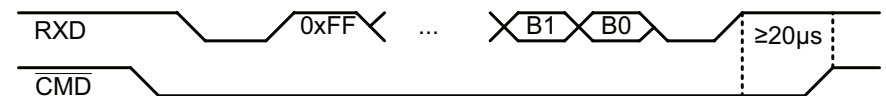

Figure 10: $\overline{\text{CMD}}$ Line Timing

The UART Interface

The module uses a standard UART interface for both data to be sent over the air and for configuring the module. The $\overline{\text{CMD}}$ line is used to tell the module if the data on the UART is for configuration or transmission. The lines follow the standard UART naming convention, so RXD is the data input into the module and TXD is the data output from the module.

The module has a 192 byte buffer for incoming data. The module can be programmed to automatically transmit when the buffer reaches a limit or based on the time between bytes on the UART. This allows the designer to optimize the module for fixed length and variable length data. The module supports streaming data as well. To optimize the module for streaming data, regUARTMTU should be set to 144, and regTXTO should be set to a value greater than 1 byte time at the current UART data rate.

If the buffer gets full or the timer set by regTXTO expires while the module is still in the process of sending the previous packet over the RF link, the module sets the $\overline{\text{CTS}}$ line high, indicating that the host should not send any more data. Data sent by the host while $\overline{\text{CTS}}$ is high is lost.

Configuration Command Formatting

The EUR Series module contains several volatile and non-volatile registers that control its configuration and operation. The volatile registers all have non-volatile mirror registers that are used to determine the default configuration when power is applied to the module. During normal operation, the volatile registers are used to control the module.

Placing the module in the command mode allows these registers to be programmed. Byte values in excess of 127 (0x80 or greater) must be changed into a two-byte escape sequence of the format:

0xFE, [value - 128]

For example, the value 0x83 becomes 0xFE, 0x03. The function in Figure 11 prepends a 0xFF header and size specifier to a command sequence and creates escape sequences as needed. It is assumed that *src is populated with either the register number to read (one byte, pass 1 into src_len) or the register number and value to write (two bytes, pass 2 into src_len). It is also assumed that the *dest buffer has enough space for the two header characters plus the encoded command and the null terminator.

```
int EscapeString(char *src, char src_len, char *dest)
{
    // The following function copies and encodes the first
    // src_len characters from *src into *dest. This
    // encoding is necessary for module command formats.
    // The resulting string is null terminated. The size
    // of this string is the function return value.
    // -----
    char src_idx, dest_idx;
    // Save space for the command header and size bytes
    // -----
    dest_idx = 2;
    // Loop through source string and copy/encode
    // -----
    for (src_idx = 0; src_idx < src_len; src_idx++)
    {
        if (src[src_idx] > 127)
        {
            dest[dest_idx++] = 0xFE;
        }/*if*/
        dest[dest_idx++] = (src[src_idx] & 0x7F);
    }/*for*/
    // Add null terminator
    // -----
    dest[dest_idx] = 0;
    // Add command header
    // -----
    dest[0] = 0xFF;
    dest[1] = dest_idx - 2;
    // Return escape string size
    // -----
    return dest_idx;
}
```

Figure 11: Command Conversion Code

Configuration Registers

The EUR Series module contains several registers that control its configuration and operation. The register settings are stored in two types of memory inside the module. Volatile memory is quick to access, but it is lost when power is removed from the module. Non-volatile memory takes longer to access, but is retained when power is removed.

All of the configuration settings have registers in both types of memory. The settings are read from non-volatile registers on power up and saved in volatile registers since it is faster to read and write the volatile memory locations. There are commands to read and write both locations.

During normal operation, the volatile registers are used to control the module. Figure 13 shows all of the configuration registers. Figure 12 shows the default values for the non-volatile registers. These are what the module uses when it powers up. Changing these values changes the module's default setting.

Non-Volatile Register Default Values			
Name	Address	Description	Default Value
regNVTXCHANNEL	0x00	Transmit channel setting	0
regNVRXCHANNEL	0x01	Receive channel setting	0
regNVPWRMODE	0x02	Operating mode settings	+13dBm DTS mode
regNVDATARATE	0x03	UART data rate	2400bps
regNVNETMODE	0x04	Network mode (Normal/Slave)	Normal
regNVTXTO	0x05	Transmit wait timeout	~16ms
regNVNETGRP	0x06	Network group ID	0x00
regNVUSECRC	0x08	Enable/disable CRC	Enabled
regNVUARTMTU	0x09	Minimum transmission unit	64 bytes
regNVSHOWVER	0x0A	Enable/disable start-up message	Enabled
regNVCSMAMODE	0x0B	Enable/disable CSMA	Enabled
regNVSLPMODE	0x0D	Power state of module	Awake

Figure 12: EUR Series Non-volatile Configuration Register Default Settings

EUR Series Configuration Registers				
Name	Address	Location	Operation	Description
regNVTXCHANNEL	0x00	NV	R/W	Transmit channel setting
regNVRXCHANNEL	0x01	NV	R/W	Receive channel setting
regNVPWRMODE	0x02	NV	R/W	Operating mode settings
regNVDATARATE	0x03	NV	R/W	UART data rate
regNVNETMODE	0x04	NV	R/W	Network mode (Normal/Slave)
regNVTXTO	0x05	NV	R/W	Transmit wait timeout
regNVNETGRP	0x06	NV	R/W	Network group ID
regNVUSECRC	0x08	NV	R/W	Enable/disable CRC
regNVUARTMTU	0x09	NV	R/W	Minimum transmission unit
regNVSHOWVER	0x0A	NV	R/W	Enable/disable start-up message
regNVCSMAMODE	0x0B	NV	R/W	Enable/disable CSMA
regNVSLPMODE	0x0D	NV	R/W	Power state of module
regMAC5	0x22	NV	R	MAC address byte 5
regMAC4	0x23	NV	R	MAC address byte 4
regMAC3	0x24	NV	R	MAC address byte 3
regMAC2	0x25	NV	R	MAC address byte 2
regMAC1	0x26	NV	R	MAC address byte 1
regMAC0	0x27	NV	R	MAC address byte 0
regTXCHANNEL	0x4B	V	R/W	Transmit channel setting
regRXCHANNEL	0x4C	V	R/W	Receive channel setting
regPWRMODE	0x4D	V	R/W	Operating mode settings
regDATARATE	0x4E	V	R/W	UART data rate
regNETMODE	0x4F	V	R/W	Network mode (normal/slave)
regTXTO	0x50	V	R/W	Transmit wait timeout
regNETGRP	0x51	V	R/W	Network group ID
regUSECRC	0x53	V	R/W	Enable/disable CRC
regUARTMTU	0x54	V	R/W	Minimum transmission unit
regCSMAMODE	0x56	V	R/W	Enable/disable CSMA
regSLPMODE	0x58	V	R/W	Power state of module

Figure 13: EUR Series Configuration Registers

Writing to Registers

Writing to a volatile register is nearly instantaneous. Writing to a non-volatile register typically takes 16ms. Because the packet size can vary based on the need for encoding, there are two possible packet structures. The first structure writes a value that is less than 128 (0x80) and the second writes a value that is higher. The higher value must be split into two values. The following tables show the byte sequences for writing a register in each case. Figure 14 shows the command to write to a register.

Write to Configuration Register Command				
Command for a Value less than 128 (0x80)				
Header	Size	Address	Value	
0xFF	0x02	REG	V1	
Command for a Value greater than 128 (0x80)				
Header	Size	Address	Value 1	Value 2
0xFF	0x03	REG	0xFE	V2

Figure 14: Write to Configuration Register Command

Warning: Be sure that the module is properly powered and remains powered for the duration of the register write. Loss of important configuration information could occur if the unit loses power during a non-volatile write cycle.

Reading from Registers

A register read command is constructed by placing an escape character (0xFE) before the register number. The module responds to this command by sending an ACK (0x06) followed by the register number and register value. The register value is sent unmodified. For example, if the register value is 0x83, 0x83 is returned. If the register number is invalid, the module responds with a NACK (0x15). The command and response are shown in Figure 15.

Read From Configuration Register			
Command			
Header	Size	Escape	Address
0xFF	0x02	0xFE	REG
Response			
ACK	Address	Value	
0x06	REG	V1	

Figure 15: Read from Configuration Register Command and Response

Channel Settings - Address = 0x4B, 0x4C; NV Address = 0x00, 0x01

The DTS Series supports 2 channels (0 – 1) in DTS mode and 6 channels (0 – 5) in low power mode.

Transmit and receive channels are set in regTXCHAN (addr 0x4B) and regRXCHAN (addr 0x4C) respectively. The non-volatile defaults are set in regNVTXCHAN (addr 0x00) and regNVRXCHAN (addr 0x01) respectively. The channel frequencies and their decimal values are shown in Figure 16.

Note: If the module is set to different transmit and receive channels then the CSMA algorithm will not work.

All modules in a network must be in the same mode (LP or DTS) and must have the same transmit and receive channels programmed in order to communicate properly.

Channel Settings						
Read Command				Read Response		
Header	Size	Escape	Address	ACK	Address	Value
0xFF	0x02	0xFE	ADDR	0x06	ADDR	CHAN
Write Command						
Header	Size	Address	Value			
0xFF	0x02	ADDR	CHAN			

Figure 17: Channel Settings Command and Response

DTS Series RF Channels		
Channel	LP Mode	DTS Mode
0	868.225	868.300
1	868.375	868.950
2	868.850	N/A
3	869.050	N/A
4	869.525	N/A
5	869.850	N/A

Figure 16: EUR Series RF Channel Numbers and Frequencies

Configuration Registers

Power Mode - Address = 0x4D; NV Address = 0x02

The Power Mode register (regPWRMODE, addr 0x4D) configures the operation mode (DTS or LP) and the transmitter output power setting. The non-volatile register (regNVPWRMODE, addr 0x02) determines the default setting on power up.

It is important to note that a module configured to operate in LP mode does not work with a module transmitting in DTS mode, or vice versa. However, a module configured to operate in any of the four DTS modes does work with any other module transmitting in any of the DTS modes.

Power Mode							
Read Command				Read Response			
Header	Size	Escape	Address	ACK	Address	Value	
0xFF	0x02	0xFE	0x4D 0x02	0x06	0x4D 0x02	V1	
Write Command							
Header	Size	Address	Value				
0xFF	0x02	0x4D 0x02	V1				

Figure 18: Power Mode Command and Response

Power Mode Register Values			
V1	Mode	Power Setting	Output Power
0x00	LP Mode	Low	-2dBm
0x01	DTS Mode	Mid-low	+2dBm
0x02	DTS Mode	Mid-high	+7dBm
0x03	DTS Mode	High	+13dBm
0x04	DTS Mode	Low	-2dBm
0x05	LP Mode	Mid-low	+2dBm
0x06	LP Mode	Mid-high	+7dBm
0x07	LP Mode	High	+13dBm

Figure 19: Power Mode Register Values

UART Data Rate - Address = 0x4E; NV Address = 0x03

The UART data rate is set by the regDATARATE (addr 0x4E) register. The default UART data rate is 2.4kbps but can be changed by setting the regNVDATARATE (addr 0x03) register.

This rate must match the rate used by the processor that is connected to the module. If the rates are not set to match, then either each rate can be tried in turn or the module can be reset to factory defaults.

The rate should be limited to 9.6kbps in LP mode. Exceeding this rate results in poor link quality.

Figure 20 shows example commands setting the UART data rate and Figure 21 shows the available UART rate settings.

UART Data Rate							
Read Command				Read Response			
Header	Size	Escape	Address	ACK	Address	Value	
0xFF	0x02	0xFE	0x4E 0x03	0x06	0x4E 0x03	V1	
Write Command							
Header	Size	Address	Value				
0xFF	0x02	0x4E 0x03	V1				

Figure 20: UART Data Rate Command and Response

UART Data Rate Register Settings	
V1	Baud Rate
0x00	2,400
0x01	9,600
0x02	19,200
0x03	38,400
0x04	57,600
0x05	115,200
0x06	10,400*
0x07	31,250*

* These data rates are not supported by PC serial ports. Selection of these rates may cause the module to fail to respond to a PC, requiring a reset to factory defaults.

Figure 21: UART Data Rate Register Settings

Network Mode - Address = 0x4F; NV Address = 0x04

The module supports two networking modes: Normal and Slave. In normal mode, the module can talk to any other module. In slave mode, the module can talk to normal-mode modules, but cannot transmit to or receive from other slaves. Slave mode is selected by writing 0x00 to this register. The default network mode is 0x01 (Normal Mode).

Network Mode							
Read Command				Read Response			
Header	Size	Escape	Address	ACK	Address	Value	
0xFF	0x02	0xFE	0x4F 0x04	0x06	0x4F 0x04	V1	
Write Command							
Header	Size	Address		Value			
0xFF	0x02	0x4F 0x04		V1			

Figure 22: Network Mode Command and Response

Network Mode Register Settings	
V1	Mode
0x00	Slave Mode
0x01	Normal Mode

Figure 23: Network Mode Register Settings

Transmit Wait Timeout - Address = 0x50; NV Address = 0x05

When a byte is received from the UART, the module starts a timer that counts down every millisecond. The timer is restarted when each byte is received. The value for this setting is the number of milliseconds to wait before transmitting the data in the UART receive buffer. The default setting for this register is 0x10 (~16ms delay).

If the timer reaches zero before the next byte is received from the UART, the module begins transmitting the data in the buffer. This timeout value should be greater than one byte time at the current UART data rate.

If the timeout value is set to 0x00, the transmit wait timeout is deactivated. In this case, the transceiver waits until a number of bytes equal to the MTU have been received by the UART. All of the bytes are sent once the MTU has been reached. Figure 24 shows examples of the commands.

Transmit Wait Timeout							
Read Command				Read Response			
Header	Size	Escape	Address	ACK	Address	Value	
0xFF	0x02	0xFE	0x50 0x05	0x06	0x50 0x05	V1	
Write Command							
Header	Size	Address		Value			
0xFF	0x02	0x50 0x05		V1			

Figure 24: Transmit Wait Timeout Command and Response

Network Group - Address = 0x51; NV Address = 0x06

Modules can be grouped into networks. Although only modules with the same network group ID can communicate, modules in different network groups but on the same RF channel still coordinate transmissions through the CSMA mechanism. Valid values for this register are decimal 0 to 127. The default group setting is 0. Figure 25 shows examples of the commands.

Network Group			
Read Command			
Header	Size	Escape	Address
0xFF	0x02	0xFE	0x51 0x06
Write Command			
Header	Size	Address	Value
0xFF	0x02	0x51 0x06	V1
Read Response			
ACK	Address	Value	
0x06	0x51 0x06	V1	

Figure 25: Network Group Command and Response

CRC Control - Address = 0x53; NV Address = 0x08

The EUR Series protocol includes a Cyclic Redundancy Check on the received packets to make sure that there are no errors. Any packets with errors are discarded and not output on the UART. This feature can be disabled if it is desired to perform error checking outside the module. Set the register to 0x01 to enable CRC checking, or 0x00 to disable it. The default CRC mode setting is enabled. Figure 26 shows examples of the commands and Figure 27 shows the available values.

CRC Control						
Read Command				Read Response		
Header	Size	Escape	Address	ACK	Address	Value
0xFF	0x02	0xFE	0x53 0x08	0x06	0x53 0x08	V1
Write Command						
Header	Size	Address	Value			
0xFF	0x02	0x53 0x08	V1			

Figure 26: CRC Control Command and Response

CRC Control Register Settings	
V1	Mode
0x00	CRC Disabled
0x01	CRC Enabled

Figure 27: CRC Control Register Settings

UART Minimum Transmission Unit - Addr = 0x54; NV Addr = 0x09

This register determines the UART buffer level that triggers the transmission of a packet. The minimum value is decimal 1 and the maximum value is 144. The default value for this register is 64, which provides a good mix of throughput and latency. Figure 28 shows examples of the commands.

UART MTU							
Read Command				Read Response			
Header	Size	Escape	Address	ACK	Address	Value	
0xFF	0x02	0xFE	0x54 0x09	0x06	0x54 0x09	V1	
Write Command							
Header	Size	Address	Value				
0xFF	0x02	0x54 0x09	V1				

Figure 28: UART MTU Command and Response

Verbose Mode - NV Address = 0x0A

Setting this register to 0x00 suppresses the start-up message, including firmware version, which is sent to the UART when the module is reset. A value of 0x01 causes the message to be output after reset. By default, the module start-up message is output. Figure 29 shows examples of the commands and Figure 30 shows the available values.

Verbose Mode							
Read Command				Read Response			
Header	Size	Escape	Address	ACK	Address	Value	
0xFF	0x02	0xFE	0x0A	0x06	0x0A	V1	
Write Command							
Header	Size	Address	Value				
0xFF	0x02	0x0A	V1				

Figure 29: Verbose Mode Command and Response

Verbose Mode Register Settings	
V1	Mode
0x00	Disable the start-up message
0x01	Enable the start-up message

Figure 30: Verbose Mode Register Settings

CSMA Enable - Address = 0x56; NV Address = 0x0B

Carrier-Sense Multiple Access (CSMA) is a best-effort delivery system that listens to the channel before transmitting a message. If another module is already transmitting when a message is queued, the module waits before sending its payload. This helps to eliminate RF message corruption at the expense of additional latency. Setting this register to 0x01 enables CSMA and 0x00 disables CSMA. By default, CSMA is enabled. Figure 31 shows examples of the commands and Figure 32 shows the available values.

CSMA Enable						
Read Command				Read Response		
Header	Size	Escape	Address	ACK	Address	Value
0xFF	0x02	0xFE	0x54 0x09	0x06	0x54 0x09	V1
Write Command						
Header	Size	Address	Value			
0xFF	0x02	0x54 0x09	V1			

Figure 31: CSMA Enable Command and Response

CSMA Enable Register Settings	
V1	Mode
0x00	Disable CSMA
0x01	Enable CSMA

Figure 32: CSMA Enable Register Settings

Sleep Control - Address = 0x58; NV Address = 0x0D

Setting this register to 0x01 places the module into Sleep mode and 0x02 places the module in Standby mode. Sleep mode places the module in the lowest power inactive state (~35µA) and requires approximately 7-8ms to resume operation once awakened. The RF section is completely shut down, and the protocol processor is in an idle, low-speed state. Any RF data sent to the module while it is in Sleep mode is lost.

In Standby mode, the RF section is powered down except for the oscillator, and the protocol processor is in an idle, low-speed state. Standby mode draws ~850µA and requires approximately 1-2ms to awaken. Any RF data sent to the module while it is in Standby mode is lost.

A sequence of four 0xFF bytes on the RXD line wakes the module up. Upon awakening, the module clears the volatile register to 0x00. The default value for this register is 0x00 (awake).

Figure 33 shows examples of the commands and Figure 34 shows the available values.

Sleep Control						
Read Command				Read Response		
Header	Size	Escape	Address	ACK	Address	Value
0xFF	0x02	0xFE	0x58 0x0D	0x06	0x58 0x0D	V1
Write Command						
Header	Size	Address	Value			
0xFF	0x02	0x58 0x0D	V1			

Figure 33: Sleep Control Command and Response

Sleep Control Register Settings	
V1	Mode
0x00	Awake
0x01	Sleep Mode
0x02	Standby Mode

Figure 34: Sleep Control Register Settings

MAC Address - NV Address = 0x22, 0x23, 0x24, 0x25, 0x26, 0x27

The MAC Address registers make a 48-bit MAC address that uniquely identifies each module. These values are factory preset and cannot be altered. These bytes are not used by the module but are provided for use as a unique address in the end applications. Figure 35 shows examples of the command.

MAC Address			
Read Command			
Header	Size	Escape	Address
0xFF	0x02	0xFE	ADDR
Read Response			
ACK	Address	Value	
0x06	ADDR	V1	

Figure 35: MAC Address Command and Response

Typical Applications

Figure 36 shows a circuit using the EUR Series transceiver.

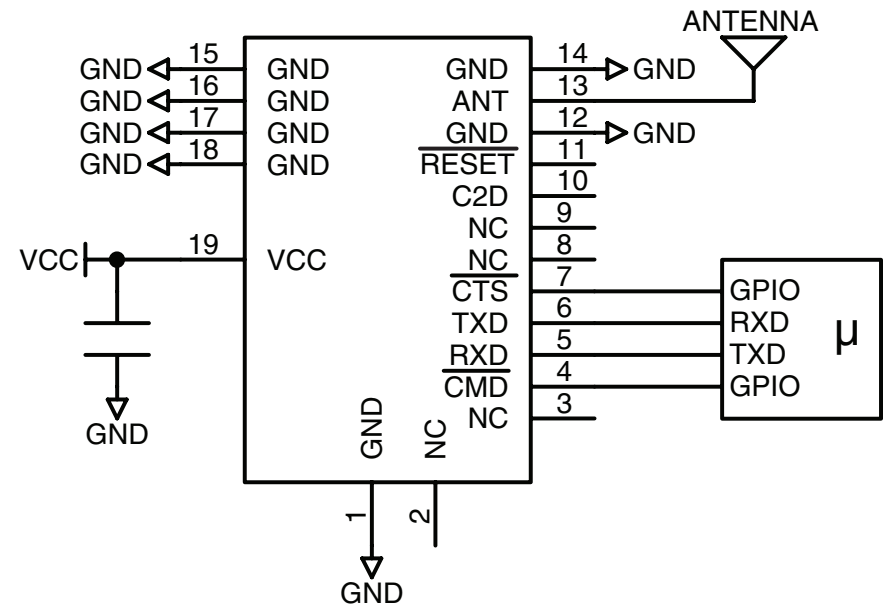

Figure 36: EUR Series Transceiver Basic Application Circuit

The transceiver UART is connected to a microcontroller UART for communication of configuration data and data to be sent over the air. There is no need for buffering or other circuitry between the transceiver and microcontroller provided that both are operating on the same voltage.

Power Supply Requirements

The module does not have an internal voltage regulator, therefore it requires a clean, well-regulated power source. The power supply noise should be less than 20mV. Power supply noise can significantly affect the module's performance, so providing a clean power supply for the module should be a high priority during design.

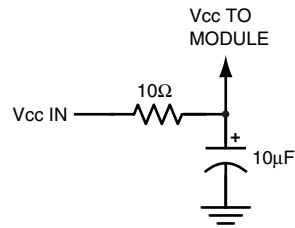

Figure 37: Supply Filter

A 10Ω resistor in series with the supply followed by a 10μF tantalum capacitor from V_{cc} to ground helps in cases where the quality of supply power is poor (Figure 37). This filter should be placed close to the module's supply lines. These values may need to be adjusted depending on the noise present on the supply line.

Antenna Considerations

The choice of antennas is a critical and often overlooked design consideration. The range, performance and legality of an RF link are critically dependent upon the antenna. While adequate antenna performance can often be obtained by trial and error methods, antenna design and matching is a complex task. Professionally designed antennas such as those from Linx (Figure 38) help ensure maximum performance and FCC and other regulatory compliance.



Figure 38: Linx Antennas

Linx transmitter modules typically have an output power that is higher than the legal limits. This allows the designer to use an inefficient antenna such as a loop trace or helical to meet size, cost or cosmetic requirements and still achieve full legal output power for maximum range. If an efficient antenna is used, then some attenuation of the output power will likely be needed.

It is usually best to utilize a basic quarter-wave whip until your prototype product is operating satisfactorily. Other antennas can then be evaluated based on the cost, size and cosmetic requirements of the product. Additional details are in Application Note AN-00500.

Helpful Application Notes from Linx

It is not the intention of this manual to address in depth many of the issues that should be considered to ensure that the modules function correctly and deliver the maximum possible performance. We recommend reading the application notes listed in Figure 39 which address in depth key areas of RF design and application of Linx products. These applications notes are available online at www.linxtechnologies.com or by contacting the Linx literature department.

Helpful Application Note Titles	
Note Number	Note Title
AN-00100	RF 101: Information for the RF Challenged
AN-00126	Considerations for Operation Within the 902–928MHz Band
AN-00130	Modulation Techniques for Low-Cost RF Data Links
AN-00140	The FCC Road: Part 15 from Concept to Approval
AN-00500	Antennas: Design, Application, Performance
AN-00501	Understanding Antenna Specifications and Operation

Figure 39: Helpful Application Note Titles

Interference Considerations

The RF spectrum is crowded and the potential for conflict with unwanted sources of RF is very real. While all RF products are at risk from interference, its effects can be minimized by better understanding its characteristics.

Interference may come from internal or external sources. The first step is to eliminate interference from noise sources on the board. This means paying careful attention to layout, grounding, filtering and bypassing in order to eliminate all radiated and conducted interference paths. For many products, this is straightforward; however, products containing components such as switching power supplies, motors, crystals and other potential sources of noise must be approached with care. Comparing your own design with a Linx evaluation board can help to determine if and at what level design-specific interference is present.

External interference can manifest itself in a variety of ways. Low-level interference produces noise and hashing on the output and reduces the link's overall range.

High-level interference is caused by nearby products sharing the same frequency or from near-band high-power devices. It can even come from your own products if more than one transmitter is active in the same area. It is important to remember that only one transmitter at a time can occupy a frequency, regardless of the coding of the transmitted signal. This type of interference is less common than those mentioned previously, but in severe cases it can prevent all useful function of the affected device.

Although technically not interference, multipath is also a factor to be understood. Multipath is a term used to refer to the signal cancellation effects that occur when RF waves arrive at the receiver in different phase relationships. This effect is a particularly significant factor in interior environments where objects provide many different signal reflection paths. Multipath cancellation results in lowered signal levels at the receiver and shorter useful distances for the link.

Pad Layout

The pad layout diagram in Figure 40 is designed to facilitate both hand and automated assembly.

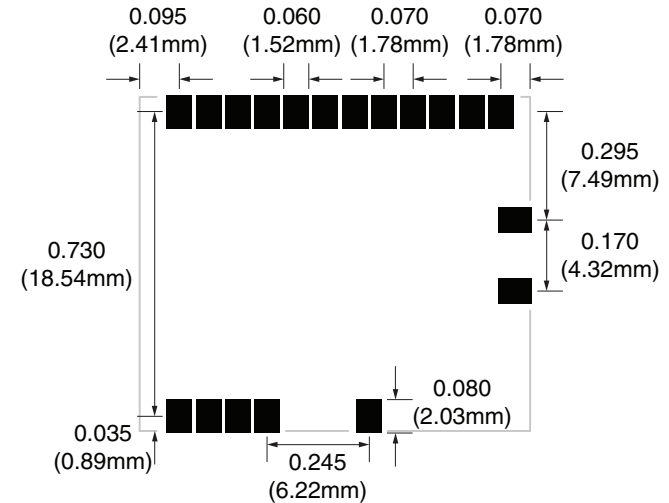

Figure 40: Recommended PCB Layout

Board Layout Guidelines

The module's design makes integration straightforward; however, it is still critical to exercise care in PCB layout. Failure to observe good layout techniques can result in a significant degradation of the module's performance. A primary layout goal is to maintain a characteristic 50-ohm impedance throughout the path from the antenna to the module. Grounding, filtering, decoupling, routing and PCB stack-up are also important considerations for any RF design. The following section provides some basic design guidelines.

During prototyping, the module should be soldered to a properly laid-out circuit board. The use of prototyping or "perf" boards results in poor performance and is strongly discouraged. Likewise, the use of sockets can have a negative impact on the performance of the module and is discouraged.

The module should, as much as reasonably possible, be isolated from other components on your PCB, especially high-frequency circuitry such as crystal oscillators, switching power supplies, and high-speed bus lines.

When possible, separate RF and digital circuits into different PCB regions.

Make sure internal wiring is routed away from the module and antenna and is secured to prevent displacement.

Do not route PCB traces directly under the module. There should not be any copper or traces under the module on the same layer as the module, just bare PCB. The underside of the module has traces and vias that could short or couple to traces on the product's circuit board.

The Pad Layout section shows a typical PCB footprint for the module. A ground plane (as large and uninterrupted as possible) should be placed on a lower layer of your PCB opposite the module. This plane is essential for creating a low impedance return for ground and consistent stripline performance.

Use care in routing the RF trace between the module and the antenna or connector. Keep the trace as short as possible. Do not pass it under the module or any other component. Do not route the antenna trace on multiple PCB layers as vias add inductance. Vias are acceptable for tying together ground layers and component grounds and should be used in multiples.

Each of the module's ground pins should have short traces tying immediately to the ground plane through a via.

Bypass caps should be low ESR ceramic types and located directly adjacent to the pin they are serving.

A 50-ohm coax should be used for connection to an external antenna. A 50-ohm transmission line, such as a microstrip, stripline or coplanar waveguide should be used for routing RF on the PCB. The Microstrip Details section provides additional information.

In some instances, a designer may wish to encapsulate or "pot" the product. There are a wide variety of potting compounds with varying dielectric properties. Since such compounds can considerably impact RF performance and the ability to rework or service the product, it is the responsibility of the designer to evaluate and qualify the impact and suitability of such materials.

Microstrip Details

A transmission line is a medium whereby RF energy is transferred from one place to another with minimal loss. This is a critical factor, especially in high-frequency products like Linx RF modules, because the trace leading to the module's antenna can effectively contribute to the length of the antenna, changing its resonant bandwidth. In order to minimize loss and detuning, some form of transmission line between the antenna and the module should be used unless the antenna can be placed very close (<1/8in) to the module. One common form of transmission line is a coax cable and another is the microstrip. This term refers to a PCB trace running over a ground plane that is designed to serve as a transmission line between the module and the antenna. The width is based on the desired characteristic impedance of the line, the thickness of the PCB and the dielectric constant of the board material. For standard 0.062in thick FR-4 board material, the trace width would be 111 mils. The correct trace width can be calculated for other widths and materials using the information in Figure 41 and examples are provided in Figure 42. Software for calculating microstrip lines is also available on the Linx website.

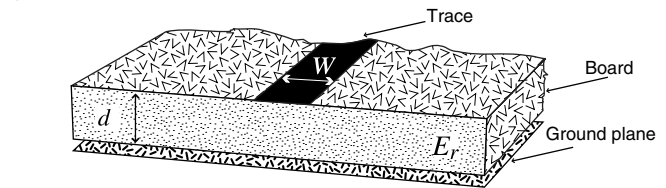

$$E_e = \frac{E_r + 1}{2} + \frac{E_r - 1}{2} \cdot \frac{1}{\sqrt{1 + 12d/W}}$$

$$Z_0 = \begin{cases} \frac{60}{\sqrt{E_e}} \cdot \ln\left(\frac{8d}{W} + \frac{W}{4d}\right) & \text{For } \frac{W}{d} \leq 1 \\ \frac{120\pi}{\sqrt{E_e} \cdot \left(\frac{W}{d} + 1.393 + 0.667 \cdot \ln\left(\frac{W}{d} + 1.444\right)\right)} & \text{For } \frac{W}{d} \geq 1 \end{cases}$$

E_r = Dielectric constant of PCB material

Figure 41: Microstrip Formulas

Example Microstrip Calculations			
Dielectric Constant	Width / Height Ratio (W / d)	Effective Dielectric Constant	Characteristic Impedance (Ω)
4.80	1.8	3.59	50.0
4.00	2.0	3.07	51.0
2.55	3.0	2.12	48.8

Figure 42: Example Microstrip Calculations

Production Guidelines

The module is housed in a hybrid SMD package that supports hand and automated assembly techniques. Since the modules contain discrete components internally, the assembly procedures are critical to ensuring the reliable function of the modules. The following procedures should be reviewed with and practiced by all assembly personnel.

Hand Assembly

Pads located on the bottom of the module are the primary mounting surface (Figure 43). Since these pads are inaccessible during mounting, castellations that run up the side of the module have been provided to facilitate solder wicking to the module's underside. This allows for very

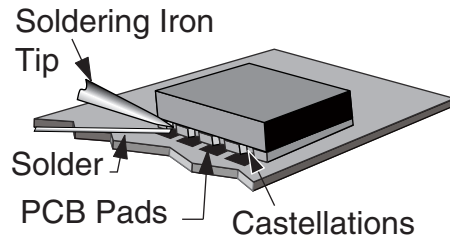

Figure 43: Soldering Technique

quick hand soldering for prototyping and small volume production. If the recommended pad guidelines have been followed, the pads will protrude slightly past the edge of the module. Use a fine soldering tip to heat the board pad and the castellation, then introduce solder to the pad at the module's edge. The solder will wick underneath the module, providing reliable attachment. Tack one module corner first and then work around the device, taking care not to exceed the times in Figure 44.

Warning: Pay attention to the absolute maximum solder times.

Absolute Maximum Solder Times

Hand Solder Temperature: +427°C for 10 seconds for lead-free alloys

Reflow Oven: +255°C max (see Figure 45)

Figure 44: Absolute Maximum Solder Times

Automated Assembly

For high-volume assembly, the modules are generally auto-placed. The modules have been designed to maintain compatibility with reflow processing techniques; however, due to their hybrid nature, certain aspects of the assembly process are far more critical than for other component types. Following are brief discussions of the three primary areas where caution must be observed.

Reflow Temperature Profile

The single most critical stage in the automated assembly process is the reflow stage. The reflow profile in Figure 45 should not be exceeded because excessive temperatures or transport times during reflow will irreparably damage the modules. Assembly personnel need to pay careful attention to the oven's profile to ensure that it meets the requirements necessary to successfully reflow all components while still remaining within the limits mandated by the modules. The figure below shows the recommended reflow oven profile for the modules.

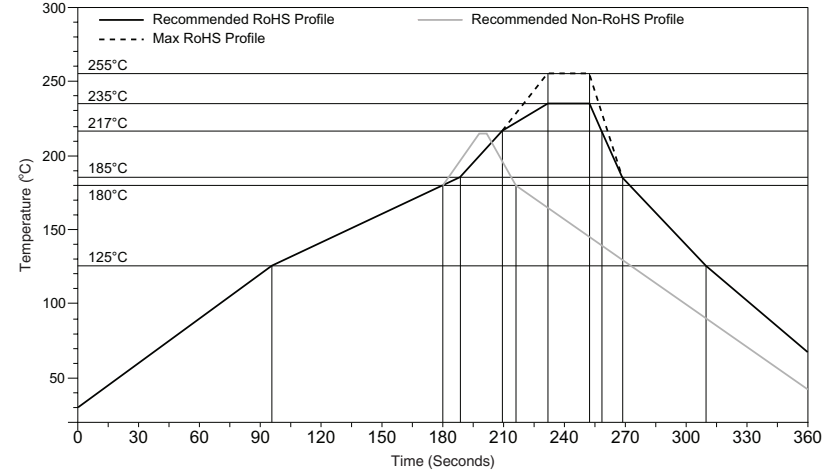

Figure 45: Maximum Reflow Temperature Profile

Shock During Reflow Transport

Since some internal module components may reflow along with the components placed on the board being assembled, it is imperative that the modules not be subjected to shock or vibration during the time solder is liquid. Should a shock be applied, some internal components could be lifted from their pads, causing the module to not function properly.

Washability

The modules are wash-resistant, but are not hermetically sealed. Linx recommends wash-free manufacturing; however, the modules can be subjected to a wash cycle provided that a drying time is allowed prior to applying electrical power to the modules. The drying time should be sufficient to allow any moisture that may have migrated into the module to evaporate, thus eliminating the potential for shorting damage during power-up or testing. If the wash contains contaminants, the performance may be adversely affected, even after drying.

General Antenna Rules

The following general rules should help in maximizing antenna performance.

1. Proximity to objects such as a user's hand, body or metal objects will cause an antenna to detune. For this reason, the antenna shaft and tip should be positioned as far away from such objects as possible.
2. Optimum performance is obtained from a $\frac{1}{4}$ - or $\frac{1}{2}$ -wave straight whip mounted at a right angle to the ground plane (Figure 46). In many cases, this isn't desirable for practical or ergonomic reasons, thus, an alternative antenna style such as a helical, loop or patch may be utilized and the corresponding sacrifice in performance accepted.

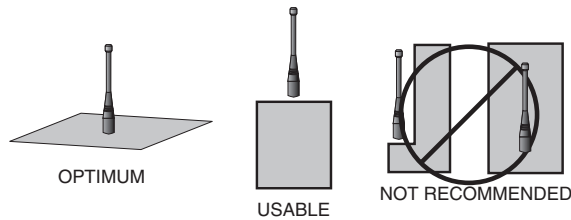

Figure 46: Ground Plane Orientation

3. If an internal antenna is to be used, keep it away from other metal components, particularly large items like transformers, batteries, PCB tracks and ground planes. In many cases, the space around the antenna is as important as the antenna itself. Objects in close proximity to the antenna can cause direct detuning, while those farther away will alter the antenna's symmetry.
4. In many antenna designs, particularly $\frac{1}{4}$ -wave whips, the ground plane acts as a counterpoise, forming, in essence, a $\frac{1}{2}$ -wave dipole (Figure 47). For this reason, adequate ground plane area is essential. The ground plane can be a metal case or ground-fill areas on a circuit board. Ideally, it should have a surface area less than or equal to the overall length of the $\frac{1}{4}$ -wave radiating element. This is often not practical due to size and configuration constraints. In these instances, a designer must make the best use of the area available to create as much ground

VERTICAL $\lambda/4$ GROUNDED ANTENNA (MARCONI)

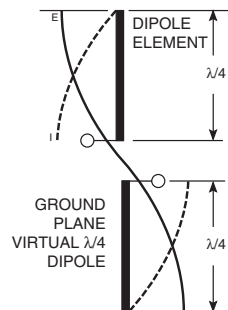

Figure 47: Dipole Antenna

plane as possible in proximity to the base of the antenna. In cases where the antenna is remotely located or the antenna is not in close proximity to a circuit board, ground plane or grounded metal case, a metal plate may be used to maximize the antenna's performance.

5. Remove the antenna as far as possible from potential interference sources. Any frequency of sufficient amplitude to enter the receiver's front end will reduce system range and can even prevent reception entirely. Switching power supplies, oscillators or even relays can also be significant sources of potential interference. The single best weapon against such problems is attention to placement and layout. Filter the module's power supply with a high-frequency bypass capacitor. Place adequate ground plane under potential sources of noise to shunt noise to ground and prevent it from coupling to the RF stage. Shield noisy board areas whenever practical.
6. In some applications, it is advantageous to place the module and antenna away from the main equipment (Figure 48). This can avoid interference problems and allows the antenna to be oriented for optimum performance. Always use 50Ω coax, like RG-174, for the remote feed.

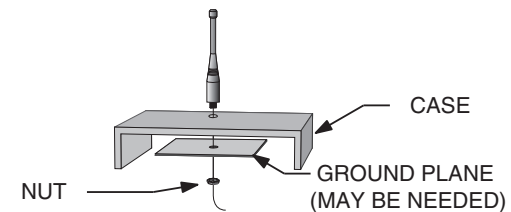

Figure 48: Remote Ground Plane

Common Antenna Styles

There are hundreds of antenna styles and variations that can be employed with Linx RF modules. Following is a brief discussion of the styles most commonly utilized. Additional antenna information can be found in Linx Application Notes AN-00100, AN-00140, AN-00500 and AN-00501. Linx antennas and connectors offer outstanding performance at a low price.

Whip Style

A whip style antenna (Figure 49) provides outstanding overall performance and stability. A low-cost whip can be easily fabricated from a wire or rod, but most designers opt for the consistent performance and cosmetic appeal of a professionally-made model. To meet this need, Linx offers a wide variety of straight and reduced height whip style antennas in permanent and connectorized mounting styles.



Figure 49: Whip Style Antennas

The wavelength of the operational frequency determines an antenna's overall length. Since a full wavelength is often quite long, a partial 1/2- or 1/4-wave antenna is normally employed. Its size and natural radiation resistance make it well matched to Linx modules. The proper length for a straight 1/4-wave can be easily determined using the formula in Figure 50. It is also possible to reduce the overall height of the antenna by using a helical winding. This reduces the antenna's bandwidth but is a great way to minimize the antenna's physical size for compact applications. This also means that the physical appearance is not always an indicator of the antenna's frequency.

$$L = \frac{234}{F_{\text{MHz}}}$$

Figure 50:
L = length in feet of quarter-wave length
F = operating frequency in megahertz

Specialty Styles

Linx offers a wide variety of specialized antenna styles (Figure 51). Many of these styles utilize helical elements to reduce the overall antenna size while maintaining reasonable performance. A helical antenna's bandwidth is often quite narrow and the antenna can detune in proximity to other objects, so care must be exercised in layout and placement.



Figure 51: Specialty Style Antennas

Loop Style

A loop or trace style antenna is normally printed directly on a product's PCB (Figure 52). This makes it the most cost-effective of antenna styles. The element can be made self-resonant or externally resonated with discrete components, but its actual layout is usually product specific. Despite the cost advantages, loop style antennas are generally inefficient and useful only for short range applications. They are also very sensitive to changes in layout and PCB dielectric, which can cause consistency issues during production. In addition, printed styles are difficult to engineer, requiring the use of expensive equipment including a network analyzer. An improperly designed loop will have a high VSWR at the desired frequency which can cause instability in the RF stage.

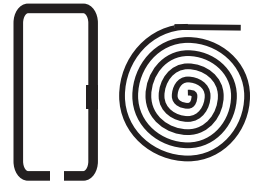

Figure 52: Loop or Trace Antenna

Linx offers low-cost planar (Figure 53) and chip antennas that mount directly to a product's PCB. These tiny antennas do not require testing and provide excellent performance despite their small size. They offer a preferable alternative to the often problematic "printed" antenna.



Figure 53: SP Series "Splatch" Antenna

Regulatory Considerations

Note: Linx RF modules are designed as component devices that require external components to function. The purchaser understands that additional approvals may be required prior to the sale or operation of the device, and agrees to utilize the component in keeping with all laws governing its use in the country of operation.

When working with RF, a clear distinction must be made between what is technically possible and what is legally acceptable in the country where operation is intended. Many manufacturers have avoided incorporating RF into their products as a result of uncertainty and even fear of the approval and certification process. Here at Linx, our desire is not only to expedite the design process, but also to assist you in achieving a clear idea of what is involved in obtaining the necessary approvals to legally market a completed product.

For information about regulatory approval, read AN-00142 on the Linx website or call Linx. Linx designs products with worldwide regulatory approval in mind.

In the United States, the approval process is actually quite straightforward. The regulations governing RF devices and the enforcement of them are the responsibility of the Federal Communications Commission (FCC). The regulations are contained in Title 47 of the United States Code of Federal Regulations (CFR). Title 47 is made up of numerous volumes; however, all regulations applicable to this module are contained in Volume 0-19. It is strongly recommended that a copy be obtained from the FCC's website, the Government Printing Office in Washington or from your local government bookstore. Excerpts of applicable sections are included with Linx evaluation kits or may be obtained from the Linx Technologies website, www.linxtechnologies.com. In brief, these rules require that any device that intentionally radiates RF energy be approved, that is, tested for compliance and issued a unique identification number. This is a relatively painless process. Final compliance testing is performed by one of the many independent testing laboratories across the country. Many labs can also provide other certifications that the product may require at the same time, such as UL, CLASS A / B, etc. Once the completed product has passed, an ID number is issued that is to be clearly placed on each product manufactured.

Questions regarding interpretations of the Part 2 and Part 15 rules or the measurement procedures used to test intentional radiators such as Linx RF modules for compliance with the technical standards of Part 15 should be addressed to:

Federal Communications Commission
Equipment Authorization Division
Customer Service Branch, MS 1300F2
7435 Oakland Mills Road
Columbia, MD, US 21046
Phone: + 1 301 725 585 | Fax: + 1 301 344 2050
Email: labinfo@fcc.gov

ETSI Secretaria
650, Route des Lucioles
06921 Sophia-Antipolis Cedex
FRANCE
Phone: +33 (0)4 92 94 42 00
Fax: +33 (0)4 93 65 47 16

International approvals are slightly more complex, although Linx modules are designed to allow all international standards to be met. If the end product is to be exported to other countries, contact Linx to determine the specific suitability of the module to the application.

All Linx modules are designed with the approval process in mind and thus much of the frustration that is typically experienced with a discrete design is eliminated. Approval is still dependent on many factors, such as the choice of antennas, correct use of the frequency selected and physical packaging. While some extra cost and design effort are required to address these issues, the additional usefulness and profitability added to a product by RF makes the effort more than worthwhile.



Linx Technologies
159 Ort Lane
Merlin, OR, US 97532

Phone: +1 541 471 6256
Fax: +1 541 471 6251

www.linxtechnologies.com

Disclaimer

Linx Technologies is continually striving to improve the quality and function of its products. For this reason, we reserve the right to make changes to our products without notice. The information contained in this Data Guide is believed to be accurate as of the time of publication. Specifications are based on representative lot samples. Values may vary from lot-to-lot and are not guaranteed. "Typical" parameters can and do vary over lots and application. Linx Technologies makes no guarantee, warranty, or representation regarding the suitability of any product for use in any specific application. It is the customer's responsibility to verify the suitability of the part for the intended application. **NO LINX PRODUCT IS INTENDED FOR USE IN ANY APPLICATION WHERE THE SAFETY OF LIFE OR PROPERTY IS AT RISK.**

Linx Technologies **DISCLAIMS ALL WARRANTIES OF MERCHANTABILITY AND FITNESS FOR A PARTICULAR PURPOSE. IN NO EVENT SHALL LINX TECHNOLOGIES BE LIABLE FOR ANY OF CUSTOMER'S INCIDENTAL OR CONSEQUENTIAL DAMAGES ARISING IN ANY WAY FROM ANY DEFECTIVE OR NON-CONFORMING PRODUCTS OR FOR ANY OTHER BREACH OF CONTRACT BY LINX TECHNOLOGIES.** The limitations on Linx Technologies' liability are applicable to any and all claims or theories of recovery asserted by Customer, including, without limitation, breach of contract, breach of warranty, strict liability, or negligence. Customer assumes all liability (including, without limitation, liability for injury to person or property, economic loss, or business interruption) for all claims, including claims from third parties, arising from the use of the Products. The Customer will indemnify, defend, protect, and hold harmless Linx Technologies and its officers, employees, subsidiaries, affiliates, distributors, and representatives from and against all claims, damages, actions, suits, proceedings, demands, assessments, adjustments, costs, and expenses incurred by Linx Technologies as a result of or arising from any Products sold by Linx Technologies to Customer. Under no conditions will Linx Technologies be responsible for losses arising from the use or failure of the device in any application, other than the repair, replacement, or refund limited to the original product purchase price. Devices described in this publication may contain proprietary, patented, or copyrighted techniques, components, or materials. Under no circumstances shall any user be conveyed any license or right to the use or ownership of such items.

©2015 Linx Technologies. All rights reserved.

The stylized Linx logo, Wireless Made Simple, WISE, CipherLinx and the stylized CL logo are trademarks of Linx Technologies.

Mouser Electronics

Authorized Distributor

Click to View Pricing, Inventory, Delivery & Lifecycle Information:

[Linx Technologies:](#)

[TRM-868-EUR](#)