

TGS 2201 - for detection of Gasoline and Diesel Exhaust Gas

Features:

- * Dual sensor element
- * High sensitivity to exhaust gases emitted by both gasoline and diesel-fueled engines
- * Long life and low cost
- * Uses simple electrical circuit

The sensing element is comprised of a metal oxide semiconductor layer formed on an alumina substrate of a sensing chip together with an integrated heater. In the presence of a detectable gas, the sensor's conductivity changes depending on the gas concentration in the air. A simple electrical circuit can convert the change in conductivity to an output signal which corresponds to the gas concentration.

The **TGS 2201** contains two independent sensing elements on one substrate and produces separate output signals for responding to diesel and gasoline exhaust gases. This feature makes TGS2201 is an ideal sensor for application in automatic damper control systems for automobile ventilation.

Applications:

- * Automobile ventilation control

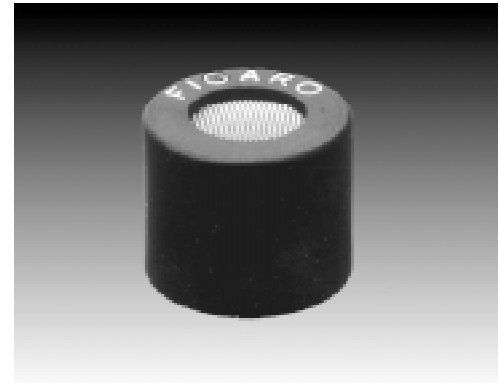

Element 1 - Diesel exhaust gas

A major component of diesel exhaust gas is NOx. The figure below represents typical sensitivity characteristics for Element 1, all data having been gathered at standard test conditions (see reverse side of this sheet). The Y-axis is indicated as *sensor resistance ratio* (R_s/R_o) which is defined as follows:

R_s = Sensor resistance in displayed gases at various concentrations

R_o = Sensor resistance in clean air

Sensitivity Characteristics:

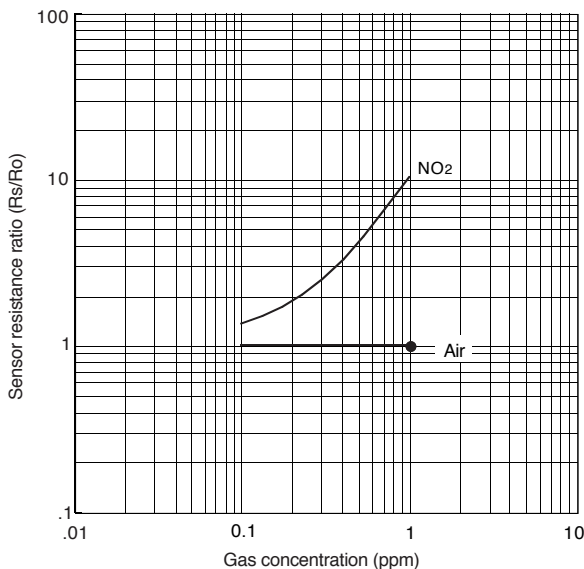

Element 2 - Gasoline exhaust gas

Gasoline exhaust gas typically contains CO, H₂, and uncombusted hydrocarbons. The figure below represents typical sensitivity characteristics for Element 2, all data having been gathered at standard test conditions (see reverse side of this sheet). The Y-axis is indicated as *sensor resistance ratio* (R_s/R_o) which is defined as follows:

R_s = Sensor resistance in displayed gases at various concentrations

R_o = Sensor resistance in clean air

Sensitivity Characteristics:

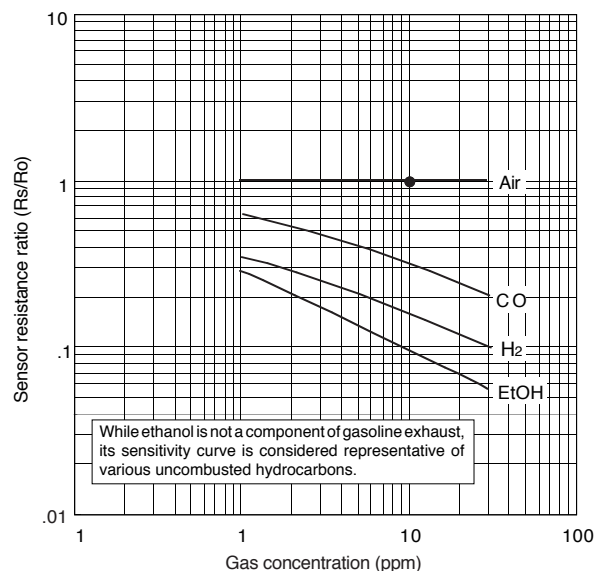

IMPORTANT NOTE: OPERATING CONDITIONS IN WHICH FIGARO SENSORS ARE USED WILL VARY WITH EACH CUSTOMER'S SPECIFIC APPLICATIONS. FIGARO STRONGLY RECOMMENDS CONSULTING OUR TECHNICAL STAFF BEFORE DEPLOYING FIGARO SENSORS IN YOUR APPLICATION AND, IN PARTICULAR, WHEN CUSTOMER'S TARGET GASES ARE NOT LISTED HEREIN. FIGARO CANNOT ASSUME ANY RESPONSIBILITY FOR ANY USE OF ITS SENSORS IN A PRODUCT OR APPLICATION FOR WHICH SENSOR HAS NOT BEEN SPECIFICALLY TESTED BY FIGARO.

Basic Measuring Circuit:

The sensor requires two voltage inputs: heater voltage (V_H) and circuit voltage (V_C). The heater voltage (V_H) is applied to the integrated heater in order to maintain the sensing element at a specific temperature which is optimal for sensing. V_C is applied to measure output voltages V_{RL1} and V_{RL2} across R_{L1} and R_{L2} respectively. Each of these load resistors are connected in series to

their corresponding sensing elements. A common power supply circuit can be used for both V_C and V_H to fulfill the sensor's electrical requirements. The value of the load resistor (R_L) should be chosen to optimize the alarm threshold value, keeping power dissipation (P_S) of the semiconductor below a limit of 15mW. Power dissipation (P_S) will be highest when the value of R_S is equal to R_L on exposure to gas.

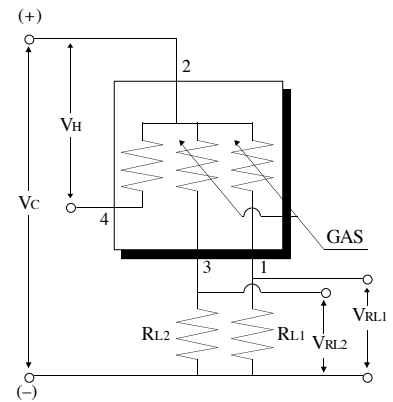

Specifications:

Model number		TGS 2201	
Sensing element type		S2	
Standard package		Plastic (P3)	
Target gases		Diesel exhaust (NO, NO ₂)	Gasoline exhaust (CO, H ₂ , HC)
Typical detection range		0.1 ~ 10 ppm	10~1,000ppm
Standard circuit conditions	Heater voltage	V _H	7.0±0.35V DC
	Circuit voltage	V _C	15.0V DC Max., P _S ≤ 15mW
	Load resistance	R _L	Variable, P _S ≤ 15mW
Electrical characteristics under standard test conditions	Heater resistance	R _H	65 ± 6Ω at room temp.
	Heater current	I _H	72mA
	Heater power consumption	P _H	505mW V _H = 7.0V DC
	Sensor resistance	R _S	250kΩ in air** 25kΩ in air**
	Sensitivity (change ratio of R _S)		$\frac{R_S(0.3ppm \text{ of } NO_2) = 2.5^{**}}{R_S(\text{air})}$ $\frac{R_S(10ppm \text{ of } H_2) = 0.35^{**}}{R_S(\text{air})}$
Standard test conditions	Test gas conditions	Air at 20±2°C, 65±5%RH	
	Circuit conditions	R _L = 200kΩ±1%	R _L = 10.0kΩ±1%
		V _C = 7.0±0.2V DC, V _H = 7.0±0.2V DC	
Conditioning period before test	7 days		

** Typical values for reference only - final specifications to be determined.

The value of power dissipation (P_S) can be calculated by utilizing the following formula:

$$P_S = \frac{(V_C - V_{RL})^2}{R_S}$$

Sensor resistance (R_S) is calculated with a measured value of V_{RL} by using the following formula:

$$R_S = \frac{V_C - V_{RL}}{V_{RL}} \times R_L$$

For information on warranty, please refer to Standard Terms and Conditions of Sale of FIGARO USA Inc.

REV: 9/99

Structure and Dimensions:

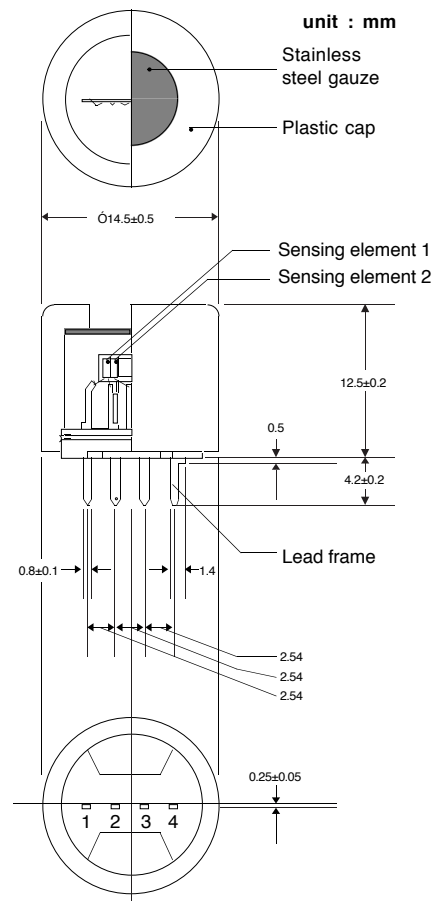

Pin connection

- 1: Sensor electrode 1(-)
- 2: Common(+)
- 3: Sensor electrode 2(-)
- 4: Heater(-)

FIGARO USA, INC.

3703 West Lake Ave. Suite 203
Glenview, Illinois 60025
Phone: (847)-832-1701
Fax: (847)-832-1705
email: figarousa@figarosensor.com