

## Wet Tantalum Capacitors Cylindrical Body, Hermetically Sealed



### FEATURES

- High temperature
- High voltage
- High capacitance
- Withstands high frequency vibration to 2000 Hz
- Hermetically sealed
- Long shelf life
- DSCC Drawings 04032 and 04033

### PERFORMANCE CHARACTERISTICS

**Operating Temperature:** - 55 °C to + 175 °C with proper derating

**Voltage Range:** 8 to 630 VDC at 85 °C

**Reverse Voltage:** None

**Capacitance Range:** 2 µF to 2200 µF

### Tolerance Range:

- 15 + 50 % (Standard for XTK, M, V)

- 15 + 75 % (Standard for XTH, L)

± 20 % (Special order)

ORDERING INFORMATION						
XTV	126	T	630	P	0	A
MODEL	CAPACITANCE CODE	CAPACITANCE TOLERANCE	DC VOLTAGE RATING	CASE CODE	INSULATION	TERMINAL CONFIGURATION
XTH XTK XTL XTM XTV	This is expressed in picofarads. The first two digits are the significant figures. The third is the number of zeros to follow.	T = - 15 + 50 % (XTK, XTM, XTV standard) U = - 15 + 75 % (XTH, XTL standard) M = ± 20 % (Special order)	This is expressed in volts. To complete the three-digit block, zeros precede the voltage rating.	P = Polar (Case negative) R = Reverse Polarity (Case Positive)	0 = Uninsulated (standard) 4 = Teflon (+ 175 °C limit)	Styles Pages 87 - 88

**Note**

For styles, terminal configurations, mounting methods and hardware, please see pages following standard ratings tables.

DIMENSIONS in inches [millimeters]		
TYPE	D	H
XTK - XTM	0.656	0.438 TO 1.781
XTL - XTH	0.875	0.540 TO 4.062
XTV	1.125	0.600 TO 2.810



**Wet Tantalum Capacitors**  
Cylindrical Body, Hermetically Sealed

<b>DIMENSIONS AND STANDARD RATINGS</b>															
CAP. ( $\mu$ F)	MAX. WORKING VOLTAGE		TYPICAL ESR ( $\Omega$ )	MAX. DCL AT MAX. WVDC IN $\mu$ A			MAX. Z - 55 °C ( $\Omega$ )	MAX. % CAP. CHANGE FROM ROOM TEMP.			APPROX WEIGHT (g)	MAX. RIPPLE 120 Hz RMS - 55 °C TO + 175 °C (mA)	SIZE		PART NUMBER
	+ 125 °C	+ 175 °C		+ 85 °C	+ 125 °C	+ 175 °C		- 55 °C	+ 85 °C	+ 175 °C			D + 0.031 - 0.015	H + 0.062 - 0.062	
<b>8 WVDC AT + 85 °C</b>															
70	7	5	10.0	30	45	60	60	- 60	+ 30	+ 30	14	137	0.656	0.438	XTK706*008P0A
140	7	5	5.0	50	75	100	30	- 60	+ 30	+ 30	15	213	0.656	0.562	XTM147*008P0A
<b>10 WVDC AT + 85 °C</b>															
50	8.5	7	10.0	25	37	50	75	- 60	+ 30	+ 30	14	137	0.656	0.438	XTK506*010P0A
100	8.5	7	5.0	45	67	90	40	- 60	+ 30	+ 30	15	213	0.656	0.562	XTM107*010P0A
<b>12 WVDC AT + 85 °C</b>															
580	10	8	1.5	135	197	270	20	- 90	+ 20	+ 35	48	550	1.125	0.600	XTV587*012P0A
850	10	8	1.5	135	197	270	20	- 90	+ 20	+ 35	50	550	1.125	0.600	XTV857*012P0A
1100	10	8	1.5	135	197	270	20	- 90	+ 20	+ 35	60	694	1.125	1.100	XTV118*012P0A
2200	10	8	1.5	135	197	270	20	- 90	+ 20	+ 35	82	694	1.125	1.100	XTV228*012P0A
<b>18 WVDC AT + 85 °C</b>															
35	15	12	10.0	30	45	60	85	- 60	+ 30	+ 30	14	137	0.656	0.438	XTK356*018P0A
70	15	12	5.0	50	75	100	45	- 60	+ 30	+ 30	15	213	0.656	0.562	XTM706*018P0A
120	15	12	2.8	50	75	100	30	- 60	+ 15	+ 40	26	328	0.875	0.540	XTL127*018P0A
240	15	12	2.5	80	120	160	20	- 60	+ 15	+ 40	32	390	0.875	0.732	XTH247*018P0A
390	15	12	1.5	165	227	330	20	- 85	+ 20	+ 35	48	550	1.125	0.600	XTV397*018P0A
560	15	12	1.5	165	227	330	20	- 85	+ 20	+ 35	50	550	1.125	0.600	XTV567*018P0A
900	15	12	1.5	165	227	330	20	- 85	+ 20	+ 35	68	694	1.125	1.100	XTV907*018P0A
1800	15	12	1.5	165	227	330	20	- 85	+ 20	+ 35	82	694	1.125	1.100	XTV188*018P0A
<b>20 WVDC AT + 85 °C</b>															
28	17.5	13	10.0	30	45	60	85	- 60	+ 30	+ 30	14	137	0.656	0.438	XTK286*020P0A
56	17.5	13	5.0	50	75	100	45	- 60	+ 30	+ 30	15	213	0.656	0.562	XTM566*020P0A
100	17.5	13	2.8	50	75	100	30	- 60	+ 15	+ 40	26	328	0.875	0.540	XTL107*020P0A
200	17.5	13	2.5	80	120	160	20	- 60	+ 15	+ 40	32	390	0.875	0.732	XTH207*020P0A
<b>30 WVDC AT + 85 °C</b>															
20	25	20	10.0	35	52	70	125	- 40	+ 20	+ 20	14	137	0.656	0.438	XTK206*030P0A
40	25	20	5.0	60	90	120	75	- 40	+ 20	+ 20	15	213	0.656	0.562	XTM406*030P0A
75	25	20	2.7	55	82	110	45	- 45	+ 15	+ 30	26	333	0.875	0.540	XTL756*030P0A
150	25	20	2.7	90	135	180	30	- 45	+ 15	+ 30	32	375	0.875	0.732	XTH157*030P0A
250	25	20	2.5	195	287	390	20	- 65	+ 20	+ 35	48	427	1.125	0.600	XTV257*030P0A
370	25	20	1.5	125	170	215	15	- 65	+ 20	+ 35	50	550	1.125	0.600	XTV377*030P0A
650	25	20	1.5	145	202	250	15	- 85	+ 20	+ 35	68	694	1.125	1.100	XTV657*030P0A
1300	25	20	1.5	190	282	375	10	- 85	+ 20	+ 35	82	694	1.125	1.100	XTV138*030P0A
<b>35 WVDC AT + 85 °C</b>															
20	30	23	10.0	35	52	72	125	- 40	+ 20	+ 20	14	137	0.656	0.438	XTK206*035P0A
40	30	23	5.0	60	90	120	75	- 40	+ 20	+ 20	15	213	0.656	0.562	XTM406*035P0A
60	30	23	2.7	55	82	110	45	- 45	+ 10	+ 30	26	333	0.875	0.540	XTL606*035P0A
<b>40 WVDC AT + 85 °C</b>															
190	34	27	2.5	195	297	400	20	- 55	+ 20	+ 35	48	427	1.125	0.600	XTV197*040P0A
290	34	27	2.5	200	300	400	20	- 55	+ 20	+ 35	50	427	1.125	0.600	XTV297*040P0A
500	34	27	1.5	200	300	400	20	- 75	+ 20	+ 35	68	694	1.125	1.100	XTV507*040P0A
1000	34	27	1.5	195	297	400	20	- 75	+ 20	+ 35	82	694	1.125	1.100	XTV108*040P0A
<b>50 WVDC AT + 85 °C</b>															
900	44	32	1.5	195	297	400	25	- 85	+ 20	+ 35	82	694	1.125	1.100	XTV907*050P0A

**Note**

\* Insert Tolerance Code: T = - 15 + 50 % (Standard for XTK, XTM, XTV)  
U = - 15 + 75 % (Standard for XTH, XTL)  
M =  $\pm$  20 % (Available by Special Order)

DIMENSIONS AND STANDARD RATINGS															
CAP. ( $\mu$ F)	MAX. WORKING		TYPICAL ESR ( $\Omega$ )	MAX. DCL AT MAX. WVDC			MAX. Z ( $\Omega$ )	MAX. % CAP. CHANGE FROM			APPROX WEIGHT (g)	MAX. RIPPLE 120 Hz RMS (mA)	SIZE		PART NUMBER
	+ 125	+ 175		+ 85	+ 125	+ 175		- 55	+ 85	+ 175			D	H	
<b>60 WVDC AT + 85 °C</b>															
12	50	40	10.0	35	52	70	180	- 30	+ 20	+ 20	14	137	0.656	0.438	XTK126*060POA
25	50	40	5.0	60	90	120	90	- 30	+ 20	+ 20	15	213	0.656	0.562	XTM256*060POA
40	50	40	2.7	60	90	120	65	- 35	+ 10	+ 20	26	333	0.875	0.540	XTL406*060POA
70	50	40	2.7	90	135	180	40	- 35	+ 10	+ 20	32	375	0.875	0.732	XTH706*060POA
80	50	40	2.7	95	142	190	35	- 35	+ 10	+ 20	32	375	0.875	0.732	XTH806*060POA
130	50	40	2.5	210	315	420	30	- 50	+ 20	+ 35	48	427	1.125	0.600	XTV137*060POA
200	50	40	1.5	135	182	230	30	- 50	+ 20	+ 35	50	550	1.125	0.600	XTV207*060POA
350	50	40	1.5	155	210	265	25	- 70	+ 20	+ 35	68	694	1.125	1.100	XTV357*060POA
700	50	40	1.5	200	275	350	15	- 70	+ 20	+ 35	82	694	1.125	1.100	XTV707*060POA
750	50	40	1.5	200	275	350	29	- 70	+ 20	+ 35	82	694	1.125	1.100	XTV757*060POA
<b>90 WVDC AT + 85 °C</b>															
8	80	60	10.0	35	52	70	250	- 30	+ 20	+ 20	14	137	0.656	0.438	XTK805*090POA
16	80	60	5.0	60	90	120	125	- 30	+ 20	+ 20	15	213	0.656	0.562	XTM166*090POA
25	80	60	2.7	55	82	110	90	- 35	+ 10	+ 20	26	333	0.875	0.540	XTL256*090POA
50	80	60	2.7	90	135	180	45	- 35	+ 10	+ 20	32	375	0.875	0.732	XTH506*090POA
84	80	60	2.5	195	287	390	40	- 40	+ 20	+ 35	48	427	1.125	0.600	XTV846*090POA
120	80	60	1.5	135	182	230	40	- 40	+ 20	+ 35	50	550	1.125	0.600	XTV127*090POA
220	80	60	1.5	145	202	250	30	- 60	+ 20	+ 35	68	694	1.125	1.100	XTV227*090POA
450	80	60	1.5	195	215	235	25	- 60	+ 20	+ 35	82	694	1.125	1.100	XTV457*090POA
<b>180 WVDC AT + 85 °C</b>															
2	160	120	20.0	75	112	150	850	- 30	+ 20	+ 20	21	108	0.656	0.719	XTK205*180POA
4	160	120	20.0	35	52	70	500	- 30	+ 20	+ 20	21	117	0.656	0.719	XTK405*180POA
8	160	120	10.0	60	90	120	250	- 30	+ 20	+ 20	23	186	0.656	0.938	XTM805*180POA
12	160	120	5.6	55	82	110	180	- 35	+ 10	+ 20	44	282	0.875	0.920	XTL126*180POA
25	160	120	5.3	90	135	180	90	- 35	+ 10	+ 20	56	341	0.875	1.300	XTH256*180POA
42	160	120	5.0	120	162	205	75	- 40	+ 20	+ 35	74	363	1.125	0.976	XTV426*180POA
60	160	120	3.0	135	182	230	60	- 40	+ 20	+ 35	78	363	1.125	0.976	XTV606*180POA
110	160	120	3.0	145	202	250	60	- 60	+ 20	+ 35	114	631	1.125	1.938	XTV117*180POA
230	160	120	3.0	200	275	350	50	- 60	+ 20	+ 35	142	631	1.125	1.938	XTV237*180POA
<b>270 WVDC AT + 85 °C</b>															
2.5	240	180	30.0	35	52	70	750	- 30	+ 20	+ 20	28	112	0.656	1.031	XTK255*270POA
5	240	180	15.0	55	82	110	375	- 30	+ 20	+ 20	31	179	0.656	1.375	XTM505*270POA
8	240	180	8.3	55	82	110	270	- 35	+ 10	+ 20	62	266	0.875	1.270	XTL805*270POA
16	240	180	8.3	90	135	180	135	- 35	+ 10	+ 20	81	320	0.875	1.865	XTH166*270POA
28	240	180	7.5	120	162	205	80	- 40	+ 20	+ 35	100	339	1.125	1.350	XTV286*270POA
40	240	180	7.5	135	182	230	100	- 40	+ 20	+ 35	104	339	1.125	1.350	XTV406*270POA
75	240	180	4.5	145	202	250	90	- 60	+ 20	+ 35	160	608	1.125	2.812	XTV756*270POA
150	240	180	4.5	195	215	235	75	- 60	+ 20	+ 35	202	608	1.125	2.812	XTV157*270POA
<b>360 WVDC AT + 85 °C</b>															
2	320	240	40.0	35	52	70	1000	- 30	+ 20	+ 20	37	108	0.656	1.312	XTK205*360POA
4	320	240	20.0	60	90	120	500	- 30	+ 20	+ 20	41	175	0.656	1.781	XTM405*360POA
6	320	240	11.0	55	82	110	360	- 35	+ 10	+ 20	80	258	0.875	1.635	XTL605*360POA
12	320	240	11.0	90	135	180	180	- 35	+ 10	+ 20	105	314	0.875	2.420	XTH126*360POA
22	320	240	10.0	125	170	215	100	- 40	+ 20	+ 35	126	323	1.125	1.705	XTV226*360POA
30	320	240	10.0	135	182	230	120	- 40	+ 20	+ 35	133	323	1.125	1.705	XTV306*360POA

**Note**

\* Insert Tolerance Code: T = - 15 + 50 % (Standard for XTK, XTM, XTV)  
 U = - 15 + 75 % (Standard for XTH, XTL)  
 M =  $\pm$  20 % (Available by Special Order)

Wet Tantalum Capacitors  
Cylindrical Body, Hermetically Sealed

DIMENSIONS AND STANDARD RATINGS															
CAP. ( $\mu$ F)	MAX. WORKING VOLTAGE		TYPICAL ESR ( $\Omega$ )	MAX. DCL AT MAX. WVDC IN $\mu$ A			MAX. Z ( $\Omega$ )	MAX. % CAP. CHANGE FROM ROOM TEMP.			APPROX WEIGHT (g)	MAX. RIPPLE 120 Hz RMS - 55 °C TO + 175 °C (mA)	SIZE		PART NUMBER
	+ 125 °C	+ 175 °C		+ 85 °C	+ 125 °C	+ 175 °C		- 55 °C	+ 85 °C	+ 175 °C			D +	H +	
													0.031	0.062	
													0.015	0.062	
<b>450 WVDC AT + 85 °C</b>															
5	400	300	13.0	55	82	110	450	- 35	+ 10	+ 20	98	262	0.875	2.000	XTL505*450P0A
10	400	300	13.0	90	135	180	225	- 35	+ 10	+ 20	130	318	0.875	2.980	XTH106*450P0A
17	400	300	12.5	125	170	215	130	- 40	+ 20	+ 35	152	315	1.125	2.080	XTV176*450P0A
25	400	300	12.5	135	182	230	150	- 40	+ 20	+ 35	164	315	1.125	2.080	XTV256*450P0A
<b>540 WVDC AT + 85 °C</b>															
4	480	360	16.6	55	82	110	540	- 35	+ 10	+ 20	114	250	0.875	2.365	XTL405*540P0A
8	480	360	16.6	90	135	180	270	- 35	+ 10	+ 20	154	306	0.875	3.532	XTH805*540P0A
14	480	300	15.0	120	162	205	160	- 40	+ 20	+ 35	178	309	1.125	2.435	XTV146*540P0A
20	480	300	15.0	135	182	230	170	- 40	+ 20	+ 35	196	309	1.125	2.435	XTV206*540P0A
<b>630 WVDC AT + 85 °C</b>															
3.5	560	420	18.9	55	82	110	630	- 35	+ 10	+ 20	133	249	0.875	2.720	XTL355*630P0A
7	560	420	18.9	90	135	180	315	- 35	+ 10	+ 20	179	308	0.875	4.062	XTH705*630P0A
12	560	420	17.5	120	162	205	180	- 40	+ 20	+ 35	204	306	1.125	2.810	XTV126T630P0
18	560	420	17.5	135	182	230	200	- 40	+ 20	+ 35	225	306	1.125	2.810	XTV186*630P0A

**Note**

\* Insert Tolerance Code: T = - 15 + 50 % (Standard for XTK, XTM, XTV)  
 U = - 15 + 75 % (Standard for XTH, XTL)  
 M =  $\pm$  20 % (Available by Special Order)

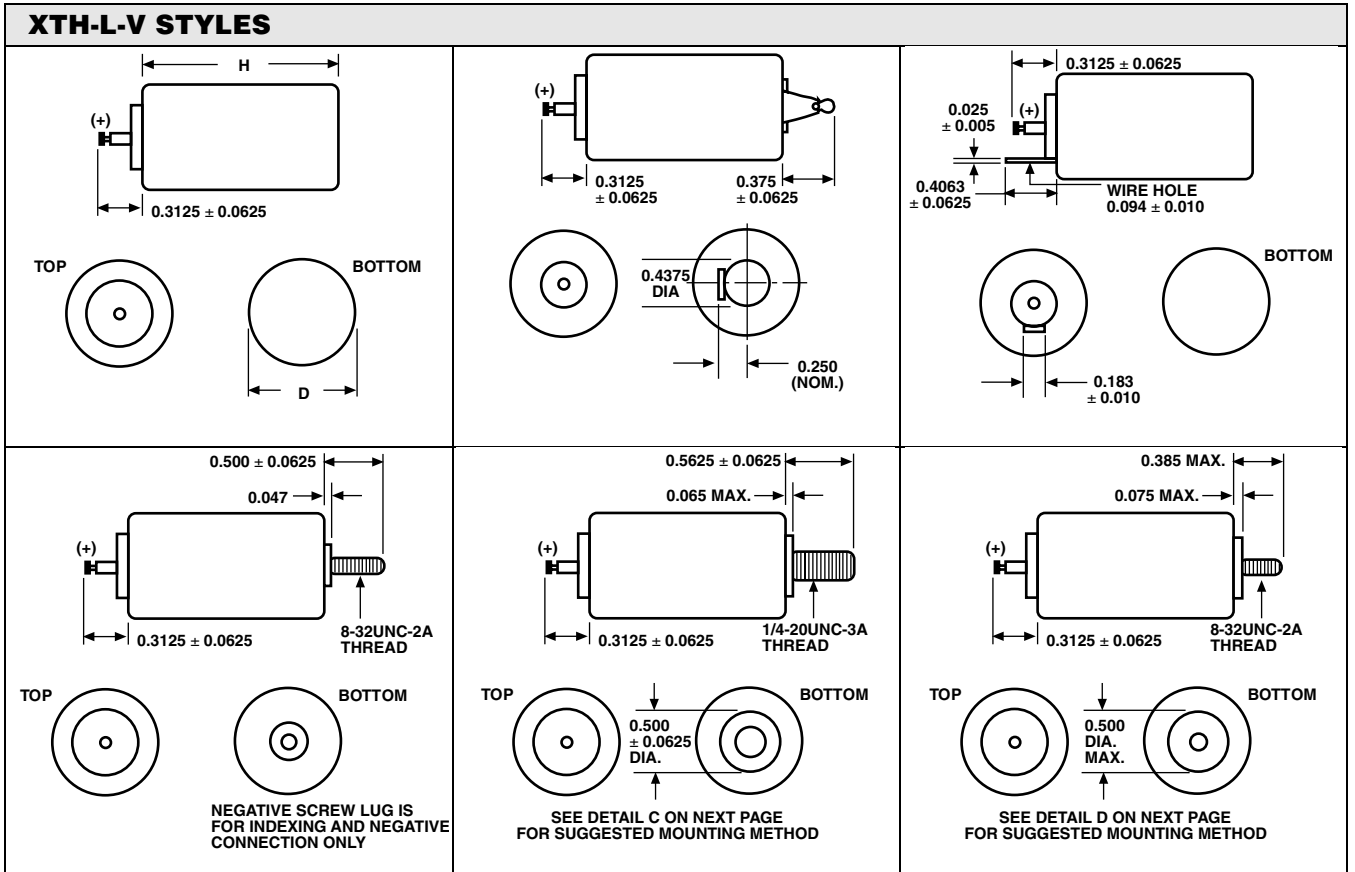

XTH-L-V STYLES		
<p><b>STYLE G</b></p> <p>TOP BOTTOM</p> <p>NEGATIVE SCREW LUG IS FOR INDEXING AND NEGATIVE CONNECTION ONLY</p>	<p><b>STYLE H</b></p> <p>TOP BOTTOM</p> <p>SEE DETAIL C ON NEXT PAGE FOR SUGGESTED MOUNTING METHOD</p>	<p><b>STYLE J</b></p> <p>TOP BOTTOM</p> <p>SEE DETAIL D ON NEXT PAGE FOR SUGGESTED MOUNTING METHOD</p>
<p><b>STYLE K</b></p> <p>TOP BOTTOM</p> <p>SEE DETAILS B &amp; E ON NEXT PAGE FOR SUGGESTED MOUNTING METHODS</p>	<p><b>STYLE L</b></p> <p>TOP BOTTOM</p> <p>SEE DETAILS B &amp; E ON NEXT PAGE FOR SUGGESTED MOUNTING METHODS</p>	<p><b>STYLE M</b></p> <p>* EXTENDS 0.125 ON 0.875 DIA. UNITS ONLY</p>

XTK-M STYLES			
<p><b>STYLE A</b></p> <p>POS NEG</p>	<p><b>STYLE B</b></p> <p>POS NEG</p>	<p><b>STYLE C</b></p> <p>POS NEG</p>	<p><b>STYLE D</b></p> <p>POS NEG</p>
<p><b>STYLE E</b></p> <p>POS NEG</p>	<p><b>STYLE F</b></p> <p>POS NEG</p>	<p><b>STYLE G</b></p> <p>POS NEG</p>	<p><b>STYLE H</b></p> <p>POS NEG</p>

Wet Tantalum Capacitors  
Cylindrical Body, Hermetically Sealed

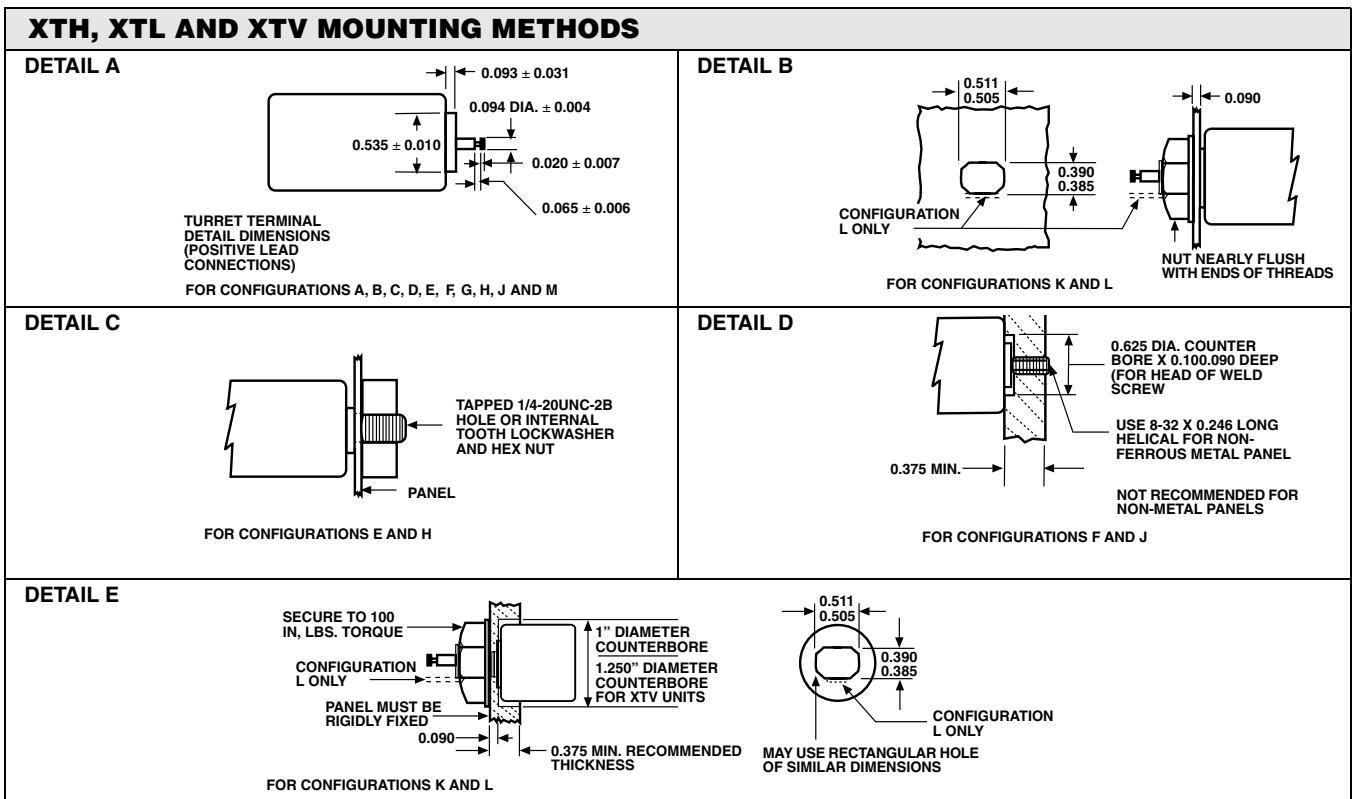
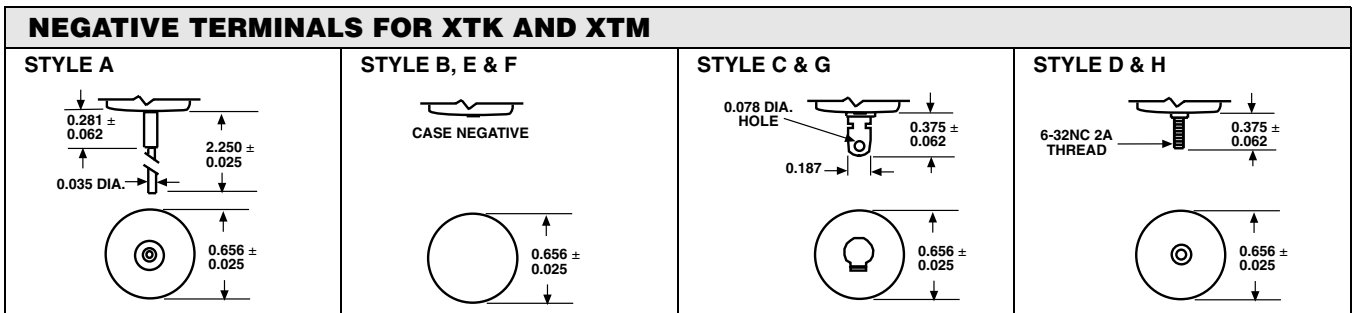
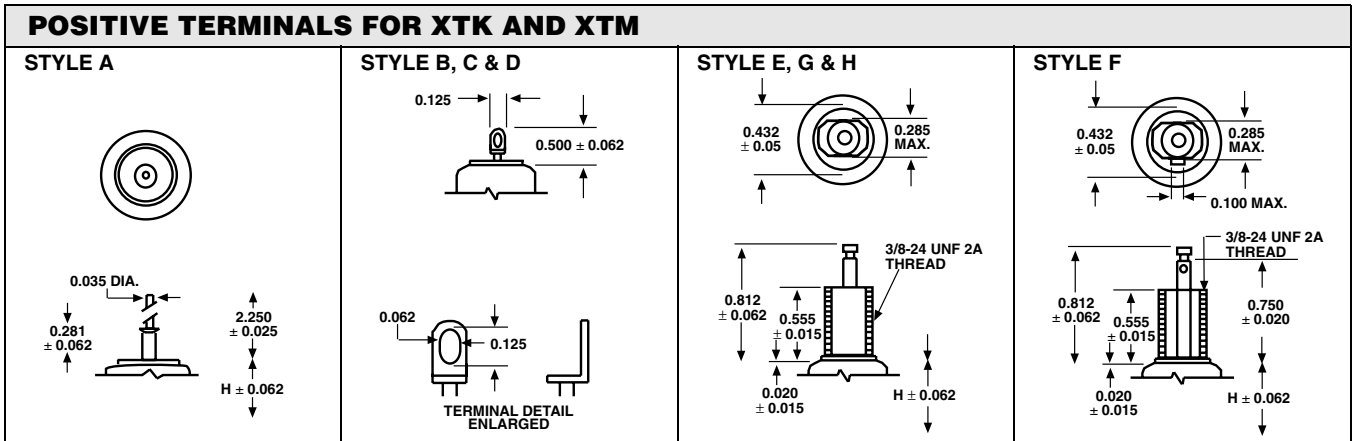
**Note**

Standard mounting nut provided is plated steel. Stainless steel nut can be obtained by adding "/STN" suffix to part number.

04022 RATINGS AND CASE CODES													
DSCC DRAWING 04022	CAP. (NOM) (μF)	CAP. TOLERANCE (%)	DC LEAKAGE MAX. (μA)			ESR MAX. 120 Hz 25 °C (Ω)	IMPEDANCE MAX. (Ω)	CAPACITANCE CHANGE %			RIPPLE CURRENT 1/ (mA)	DIMENSION L ± 0.062 (1.57) (INCHES)	FIGURE
PIN			+25 °C	+85 °C	+125 °C			-55 °C	+85 °C	+125 °C			
<b>8 VDC AT + 85 °C RATED, 9.2 VDC AT + 85 °C SURGE</b>													
01	70	+ 50, - 15	6	30	48	12	60	- 60	+ 30	+ 30	137	0.438 (11.13)	1A
02	140	+ 50, - 15	10	50	80	5.9	30	- 60	+ 30	+ 30	213	0.562 (14.27)	1A
<b>10 VDC AT + 85 °C RATED, 11.5 VDC AT + 85 °C SURGE</b>													
03	50	+ 50, - 15	5	25	40	11.7	75	- 60	+ 30	+ 30	137	0.438 (11.13)	1A
04	100	+ 50, - 15	9	45	72	5.9	40	- 60	+ 30	+ 30	213	0.562 (14.27)	1A
<b>20 VDC AT + 85 °C RATED, 23 VDC AT + 85 °C SURGE</b>													
05	28	+ 50, - 15	6	30	48	12	85	- 40	+ 20	+ 20	137	0.438 (11.13)	1A
06	56	+ 50, - 15	10	50	80	6	45	- 40	+ 20	+ 20	213	0.562 (14.27)	1A
<b>30 VDC AT + 85 °C RATED, 34.5 VDC AT + 85 °C SURGE</b>													
07	20	+ 50, - 15	7	35	56	11.7	125	- 40	+ 20	+ 20	137	0.438 (11.13)	1A
08	40	+ 50, - 15	12	60	96	5.9	75	- 40	+ 20	+ 20	213	0.562 (14.27)	1A
<b>60 VDC AT + 85 °C RATED, 69 VDC AT + 85 °C SURGE</b>													
09	12	+ 50, - 15	7	35	56	12	180	- 30	+ 20	+ 20	137	0.438 (11.13)	1A
10	25	+ 50, - 15	12	60	96	6	90	- 30	+ 20	+ 20	213	0.562 (14.27)	1A
<b>90 VDC AT + 85 °C RATED, 103 VDC AT + 85 °C SURGE</b>													
11	8	+ 50, - 15	7	35	56	12	250	- 30	+ 20	+ 20	137	0.438 (11.13)	1A
12	16	+ 50, - 15	12	60	96	5.9	125	- 30	+ 20	+ 20	213	0.562 (14.27)	1A
<b>180 VDC AT + 85 °C RATED, 207 VDC AT + 85 °C SURGE</b>													
13	4	+ 50, - 15	7	35	56	24	500	- 30	+ 20	+ 20	117	0.719 (18.26)	1A
14	8	+ 50, - 15	12	60	96	12	250	- 30	+ 20	+ 20	186	0.938 (23.83)	1A
<b>270 VDC AT + 85 °C RATED, 310 VDC AT + 85 °C SURGE</b>													
15	2.5	+ 50, - 15	7	35	56	36	750	- 30	+ 20	+ 20	112	1.031 (26.19)	1A
16	5	+ 50, - 15	11	55	88	18	375	- 30	+ 20	+ 20	179	1.375 (34.93)	1A
<b>360 VDC AT + 85 °C RATED, 414 VDC AT + 85 °C SURGE</b>													
17	2	+ 50, - 15	7	35	56	48	1000	- 30	+ 20	+ 20	108	1.312 (33.32)	1A
18	4	+ 50, - 15	12	60	96	24	500	- 30	+ 20	+ 20	175	1.781 (45.24)	1A
<b>20 VDC AT + 85 °C RATED, 23 VDC AT + 85 °C SURGE</b>													
19	100	+ 50, - 15	10	50	80	3.3	30	- 60	+ 15	+ 20	333	0.540 (13.72)	1B
20	200	+ 75, - 15	16	80	128	2.8	20	- 60	+ 15	+ 20	375	0.732 (18.59)	1B
<b>30 VDC AT + 85 °C RATED, 34.5 VDC AT + 85 °C SURGE</b>													
21	75	+ 75, - 15	11	55	88	3.1	45	- 45	+ 10	+ 10	333	0.540 (13.72)	1B
22	150	+ 75, - 15	13	90	104	3	30	- 45	+ 10	+ 10	375	0.732 (18.59)	1B
<b>60 VDC AT + 85 °C RATED, 69 VDC AT + 85 °C SURGE</b>													
23	40	+ 75, - 15	12	60	96	3.2	65	- 35	+ 10	+ 10	333	0.540 (13.72)	1B
24	80	+ 75, - 15	19	95	152	3.1	35	- 35	+ 10	+ 10	375	0.732 (18.59)	1B
<b>90 VDC AT + 85 °C RATED, 103 VDC AT + 85 °C SURGE</b>													
25	25	+ 75, - 15	11	55	88	3.2	90	- 35	+ 10	+ 10	333	0.540 (13.72)	1B
26	50	+ 75, - 15	18	90	144	3.1	45	- 35	+ 10	+ 10	375	0.732 (18.59)	1B
<b>180 VDC AT + 85 °C RATED, 207 VDC AT + 85 °C SURGE</b>													
27	12	+ 75, - 15	11	55	88	6.6	180	- 35	+ 10	+ 10	282	0.920 (23.37)	1B
28	25	+ 75, - 15	18	90	144	6.2	90	- 35	+ 10	+ 10	341	1.300 (33.02)	1B
<b>270 VDC AT + 85 °C RATED, 310 VDC AT + 85 °C SURGE</b>													
29	8	+ 75, - 15	11	55	88	9.9	270	- 35	+ 10	+ 10	266	1.270 (32.36)	1B
30	16	+ 75, - 15	18	90	144	9.8	135	- 35	+ 10	+ 10	320	1.865 (47.37)	1B
<b>360 VDC AT + 85 °C RATED, 414 VDC AT + 85 °C SURGE</b>													
31	6	+ 75, - 15	11	55	88	13	360	- 35	+ 10	+ 10	258	1.635 (41.53)	1B
32	12	+ 75, - 15	18	90	144	13	180	- 35	+ 10	+ 10	314	2.420 (61.47)	1B
<b>450 VDC AT + 85 °C RATED, 518 VDC AT + 85 °C SURGE</b>													
33	5	+ 75, - 15	11	55	88	15	450	- 35	+ 10	+ 10	252	2.000 (50.80)	1B
34	10	+ 75, - 15	18	90	144	15	225	- 35	+ 10	+ 10	308	2.980 (75.69)	1B
<b>540 VDC AT + 85 °C RATED, 621 VDC AT + 85 °C SURGE</b>													
35	4	+ 75, - 15	11	55	88	20	540	- 35	+ 10	+ 10	250	2.365 (60.07)	1B
36	8	+ 75, - 15	18	90	144	20	270	- 35	+ 10	+ 10	308	3.532 (89.71)	1B
<b>630 VDC AT + 85 °C RATED, 724 VDC AT + 85 °C SURGE</b>													
37	3.5	+ 75, - 15	11	55	88	22	630	- 35	+ 10	+ 10	250	2.720 (69.09)	1B



Wet Tantalum Capacitors  
Cylindrical Body, Hermetically Sealed

04022 RATINGS AND CASE CODES													
DSCC DRAWING 04022 PIN	CAP. (NOM) (µF)	CAP. TOLERANCE (%)	DC LEAKAGE MAX. (µA)			ESR MAX. 120 Hz 25 °C (Ω)	IMPEDANCE MAX. (Ω)	CAPACITANCE CHANGE %			RIPPLE CURRENT 1/ (mA)	DIMENSION L ± 0.062 (1.57) (INCHES)	FIGURE
			+ 25 °C	+ 85 °C	+ 125 °C			- 55 °C	+ 85 °C	+ 125 °C			
<b>30 VDC AT + 85 °C RATED, 34.5 VDC AT + 85 °C SURGE</b>													
39	370	± 20	18	125	180	1.7	15	- 65	+ 20	+ 25	550	0.600 (15.24)	1C
40	370	+ 50, - 15	18	125	180	1.7	15	- 65	+ 20	+ 25	550	0.600 (15.24)	1C
41	650	± 20	21	145	210	1.8	15	- 85	+ 20	+ 25	694	1.100 (27.94)	1C
42	650	+ 50, - 15	21	145	210	1.8	15	- 85	+ 20	+ 25	694	1.100 (27.94)	1C
43	1300	± 20	27	190	270	1.8	10	- 85	+ 20	+ 25	694	1.100 (27.94)	1C
44	1300	+ 50, - 15	27	190	270	1.8	10	- 85	+ 20	+ 25	694	1.100 (27.94)	1C
<b>60 VDC AT + 85 °C RATED, 69 VDC AT + 85 °C SURGE</b>													
45	200	± 20	19	135	190	1.8	30	- 50	+ 20	+ 25	550	0.600 (15.24)	1C
46	200	+ 50, - 15	19	135	190	1.8	30	- 50	+ 20	+ 25	550	0.600 (15.24)	1C
47	350	± 20	22	155	220	1.8	25	- 70	+ 20	+ 25	694	1.100 (27.94)	1C
48	350	+ 50, - 15	22	155	220	1.8	25	- 70	+ 20	+ 25	694	1.100 (27.94)	1C
49	700	± 20	29	200	290	1.8	15	- 70	+ 20	+ 25	694	1.100 (27.94)	1C
50	700	+ 50, - 15	29	200	290	1.8	15	- 70	+ 20	+ 25	694	1.100 (27.94)	1C
<b>90 VDC AT + 85 °C RATED, 103 VDC AT + 85 °C SURGE</b>													
51	120	± 20	19	135	190	1.7	40	- 40	+ 20	+ 25	550	0.600 (15.24)	1C
52	120	+ 50, - 15	19	135	190	1.7	40	- 40	+ 20	+ 25	550	0.600 (15.24)	1C
53	220	± 20	21	145	210	1.8	30	- 60	+ 20	+ 25	694	1.100 (27.94)	1C
54	220	+ 50, - 15	21	145	210	1.8	30	- 60	+ 20	+ 25	694	1.100 (27.94)	1C
55	450	± 20	29	195	290	1.7	35	- 60	+ 20	+ 25	694	1.100 (27.94)	1C
56	450	+ 50, - 15	29	195	290	1.7	35	- 60	+ 20	+ 25	694	1.100 (27.94)	1C
<b>180 VDC AT + 85 °C RATED, 207 VDC AT + 85 °C SURGE</b>													
57	42	± 20	17	120	170	6	75	- 40	+ 20	+ 25	363	0.976 (24.79)	1C
58	42	+ 50, - 15	17	120	170	6	75	- 40	+ 20	+ 25	363	0.976 (24.79)	1C
59	60	± 20	19	135	190	3.4	60	- 40	+ 20	+ 25	363	0.976 (24.79)	1C
60	60	+ 50, - 15	19	135	190	3.4	60	- 40	+ 20	+ 25	363	0.976 (24.79)	1C
61	110	± 20	21	145	210	3.5	60	- 60	+ 20	+ 25	631	1.938 (49.23)	1C
62	110	+ 50, - 15	21	145	210	3.5	60	- 60	+ 20	+ 25	631	1.938 (49.23)	1C
63	230	± 20	29	200	290	3.5	50	- 60	+ 20	+ 25	631	1.938 (49.23)	1C
64	230	+ 50, - 15	29	200	290	3.5	50	- 60	+ 20	+ 25	631	1.938 (49.23)	1C
<b>270 VDC AT + 85 °C RATED, 310 VDC AT + 85 °C SURGE</b>													
65	28	± 20	19	120	190	9	80	- 40	+ 20	+ 25	339	1.350 (34.29)	1C
66	28	+ 50, - 15	19	120	190	9	80	- 40	+ 20	+ 25	339	1.350 (34.29)	1C
67	40	± 20	19	135	190	8.8	100	- 40	+ 20	+ 25	339	1.350 (34.29)	1C
68	40	+ 50, - 15	19	135	190	8.8	100	- 40	+ 20	+ 25	339	1.350 (34.29)	1C
69	75	± 20	21	145	210	5.2	90	- 60	+ 20	+ 25	608	2.812 (71.42)	1C
70	75	+ 50, - 15	21	145	210	5.2	90	- 60	+ 20	+ 25	608	2.812 (71.42)	1C
71	150	± 20	28	195	280	5.4	75	- 60	+ 20	+ 25	608	2.812 (71.42)	1C
72	150	+ 50, - 15	28	195	280	5.4	75	- 60	+ 20	+ 25	608	2.812 (71.42)	1C
<b>360 VDC AT + 85 °C RATED, 414 VDC AT + 85 °C SURGE</b>													
73	22	± 20	18	125	180	11.4	100	- 40	+ 20	+ 25	323	1.705 (43.31)	1C
74	22	+ 50, - 15	18	125	180	11.6	100	- 40	+ 20	+ 25	323	1.705 (43.31)	1C
75	30	± 20	19	135	190	11.7	120	- 40	+ 20	+ 25	323	1.705 (43.31)	1C
76	30	+ 50, - 15	19	135	190	11.7	120	- 40	+ 20	+ 25	323	1.705 (43.31)	1C
<b>450 VDC AT + 85 °C RATED, 518 VDC AT + 85 °C SURGE</b>													
77	17	± 20	18	125	180	15	130	- 40	+ 20	+ 25	315	2.080 (52.83)	1C
78	17	+ 50, - 15	18	125	180	15	130	- 40	+ 20	+ 25	315	2.080 (52.83)	1C
79	25	± 20	19	135	190	15	150	- 40	+ 20	+ 25	315	2.080 (52.83)	1C
80	25	+ 50, - 15	19	135	190	15	150	- 40	+ 20	+ 25	315	2.080 (52.83)	1C



04022 RATINGS AND CASE CODES													
DSCC DRAWING	CAP. (NOM)	CAP. TOLERANCE	DC LEAKAGE MAX. (µA)			ESR MAX. 120 Hz 25 °C	IMPEDANCE MAX.	CAPACITANCE CHANGE %			RIPPLE CURRENT 1/	DIMENSION L ± 0.062 (1.57)	FIGURE
04022	(µF)	(%)	+ 25 °C	+ 85 °C	+ 125 °C	(Ω)	(Ω)	- 55 °C	+ 85 °C	+ 125 °C	(mA)	(INCHES)	
<b>540 VDC AT + 85 °C RATED, 621 VDC AT + 85 °C SURGE</b>													
81	14	± 20	17	120	170	18	160	- 40	+ 20	+ 25	309	2.435 (61.85)	1C
82	14	+ 50, - 15	17	120	170	18	160	- 40	+ 20	+ 25	309	2.435 (61.85)	1C
83	20	± 20	19	135	190	18	170	- 40	+ 20	+ 25	309	2.435 (61.85)	1C
84	20	+ 50, - 15	19	135	190	18	170	- 40	+ 20	+ 25	309	2.435 (61.85)	1C
<b>630 VDC AT + 85 °C RATED, 724 VDC AT + 85 °C SURGE</b>													
85	12	± 20	17	120	170	16	180	- 40	+ 20	+ 25	306	2.810 (71.37)	1C
86	12	+ 50, - 15	17	120	170	16	180	- 40	+ 20	+ 25	306	2.810 (71.37)	1C
87	18	± 20	19	135	190	16	200	- 40	+ 20	+ 25	306	2.810 (71.37)	1C
88	18	+ 50, - 15	19	135	190	16	200	- 40	+ 20	+ 25	306	2.810 (71.37)	1C

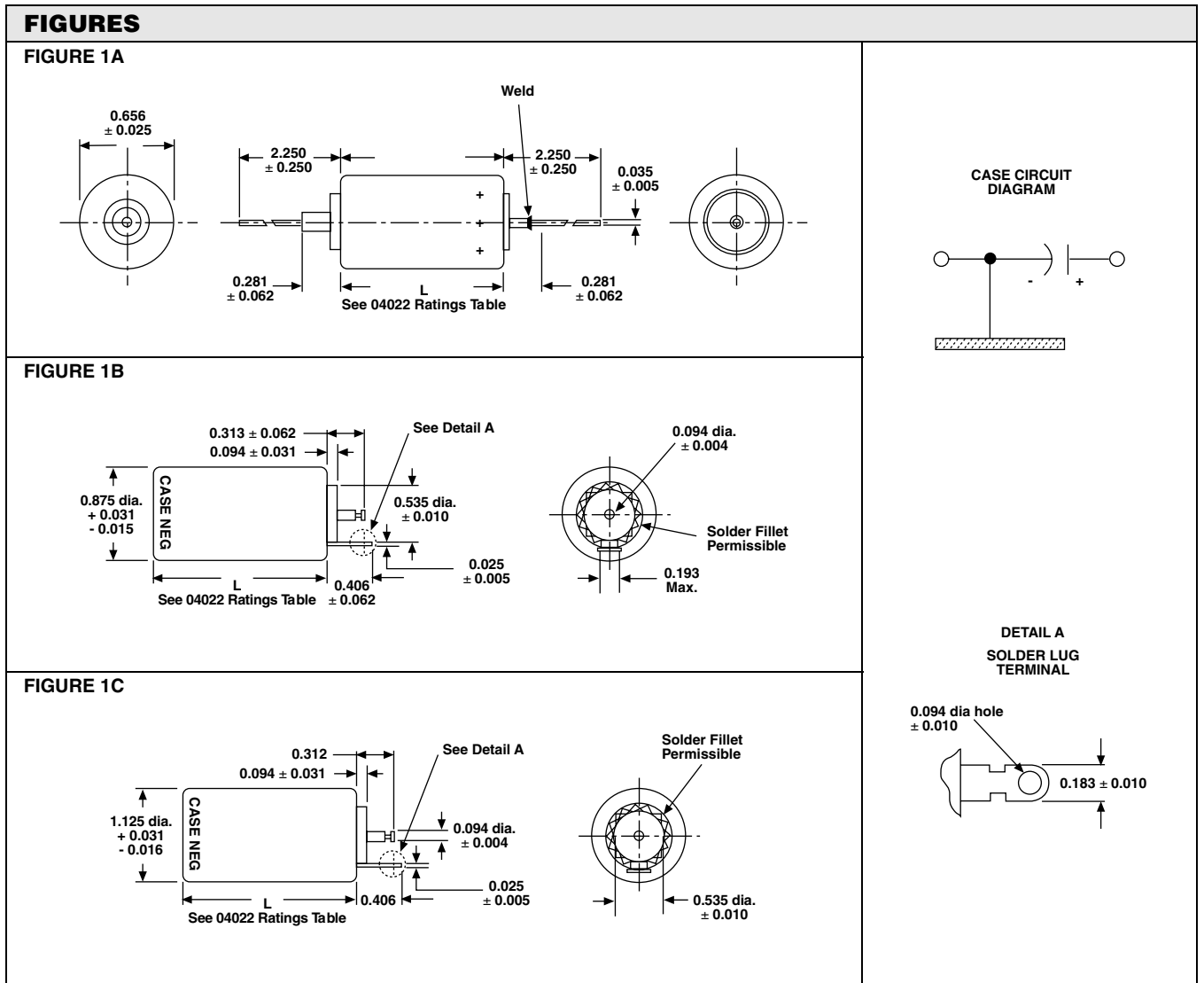



## Disclaimer

All product specifications and data are subject to change without notice.

Vishay Intertechnology, Inc., its affiliates, agents, and employees, and all persons acting on its or their behalf (collectively, "Vishay"), disclaim any and all liability for any errors, inaccuracies or incompleteness contained herein or in any other disclosure relating to any product.

Vishay disclaims any and all liability arising out of the use or application of any product described herein or of any information provided herein to the maximum extent permitted by law. The product specifications do not expand or otherwise modify Vishay's terms and conditions of purchase, including but not limited to the warranty expressed therein, which apply to these products.

No license, express or implied, by estoppel or otherwise, to any intellectual property rights is granted by this document or by any conduct of Vishay.

The products shown herein are not designed for use in medical, life-saving, or life-sustaining applications unless otherwise expressly indicated. Customers using or selling Vishay products not expressly indicated for use in such applications do so entirely at their own risk and agree to fully indemnify Vishay for any damages arising or resulting from such use or sale. Please contact authorized Vishay personnel to obtain written terms and conditions regarding products designed for such applications.

Product names and markings noted herein may be trademarks of their respective owners.