

Entwicklung

Hardware

Pinbelegung

Pegel

Segmentnutzung/Kontaktbelegung

spannungsversorgung

schaltplan

controller anbindung

interface

adapter/schaltplan

uart einstellungen

Software

pc front end

protokoll

pap Ablaufplan

betriebsarten

send

prog

adr

answer/request

adapter für pc

umprogrammieren

Übersicht

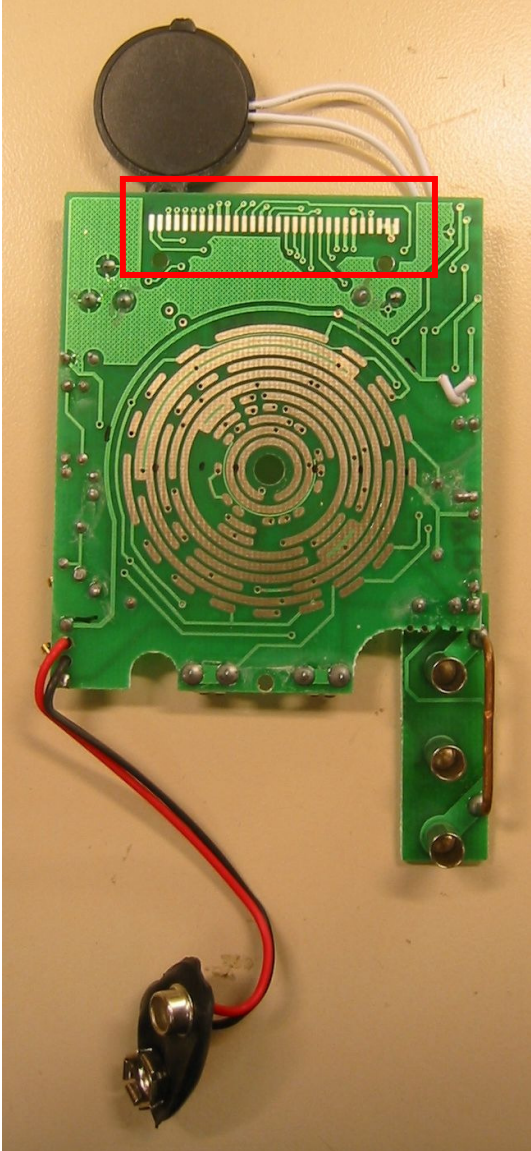

Display Pinbelegung

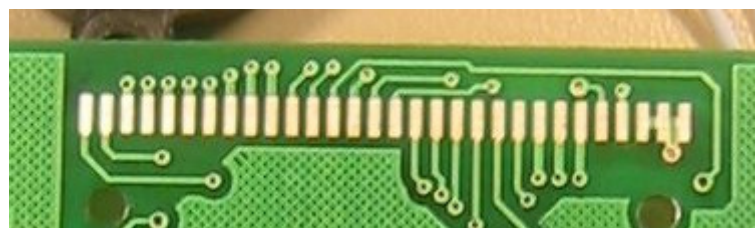
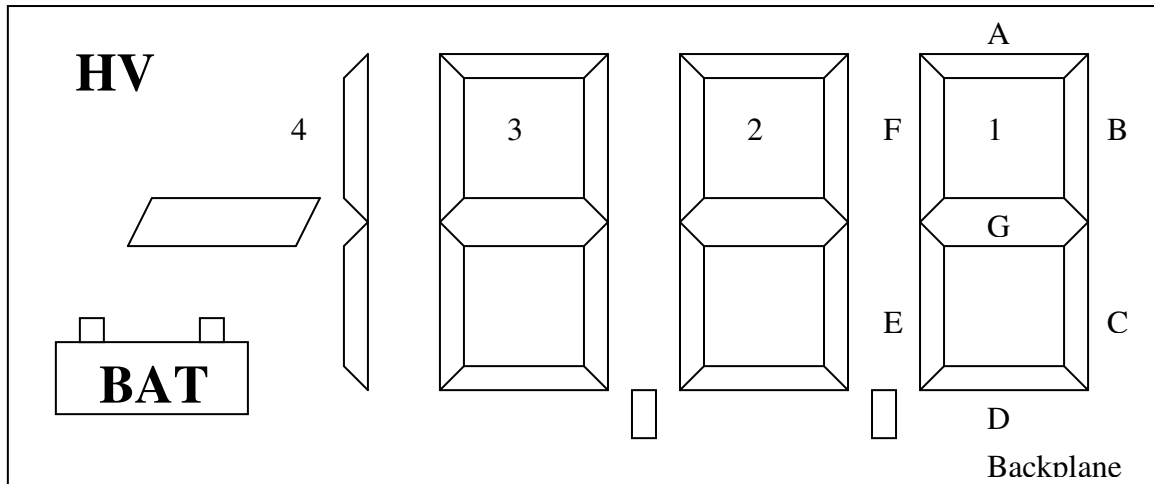

- 30
- 29
- 28
- 27
- 26
- 25
- 24
- 23
- 22
- 21
- 20
- 19
- 18
- 17
- 16
- 15
- 14
- 13
- 12
- 11
- 10
- 09
- 08
- 07
- 06
- 05
- 04
- 03
- 02
- 01

Pinbelegung am Chip

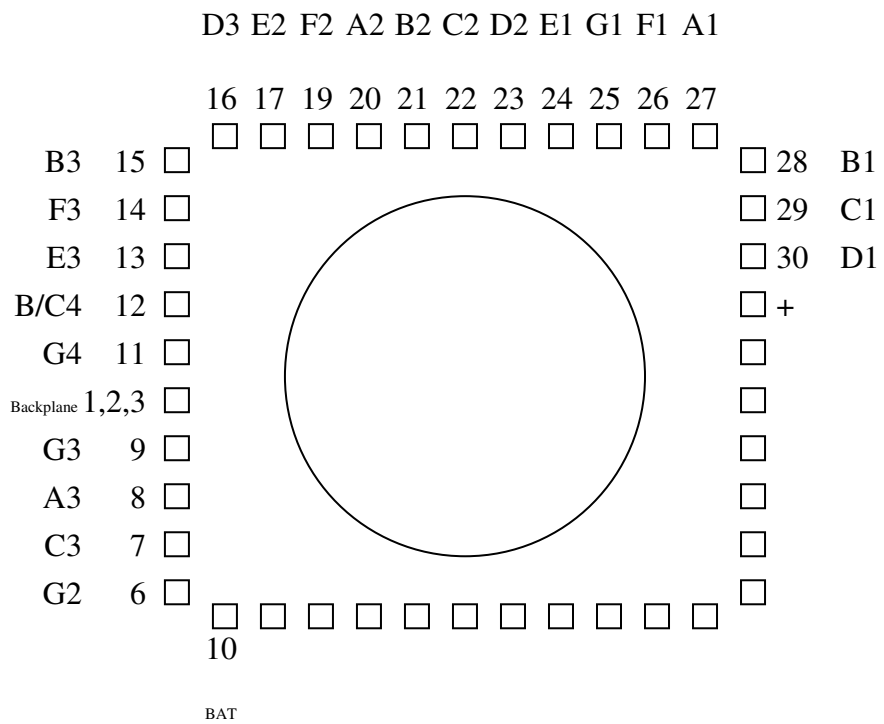
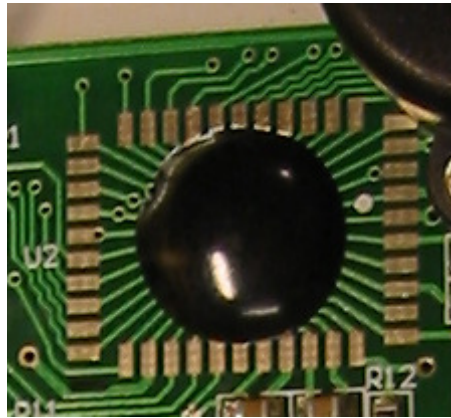

Pegel am Segment

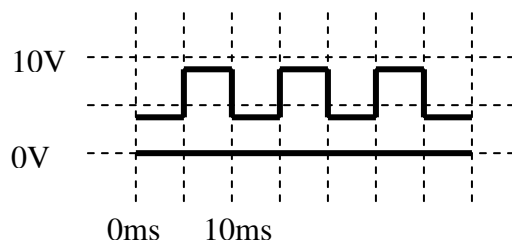
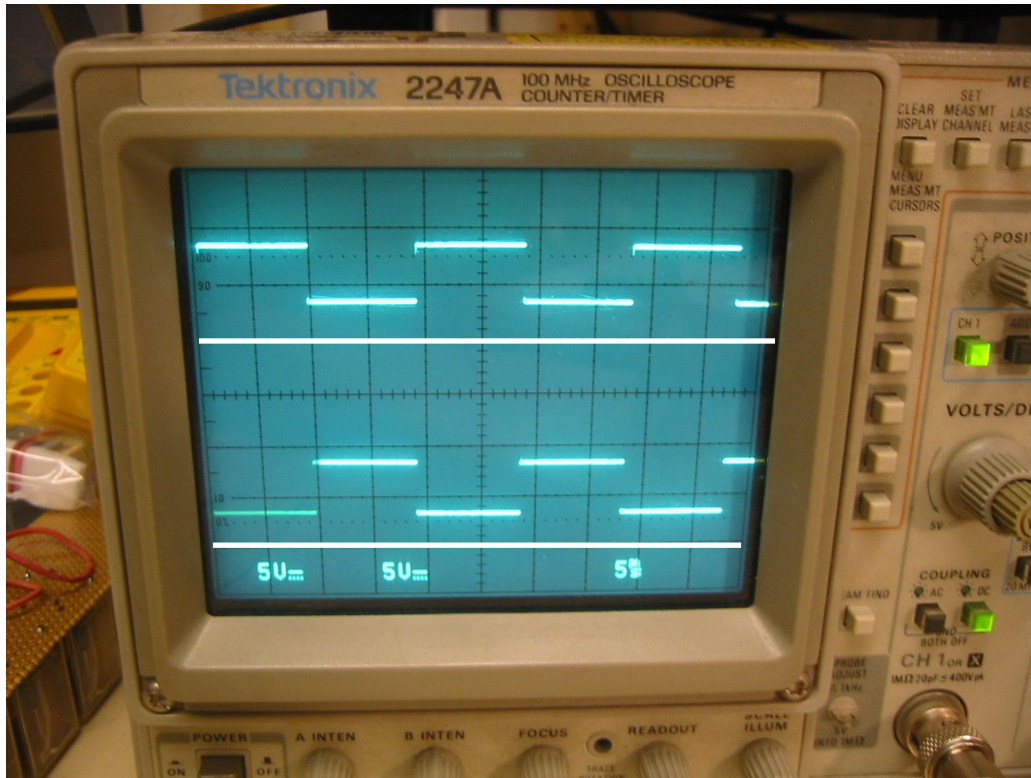

SIGNAL @ 1,2,3 Backplane Display

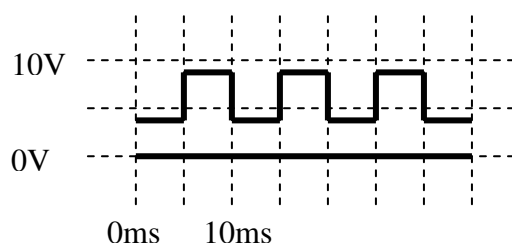

SIGNAL @ Segment (Off)

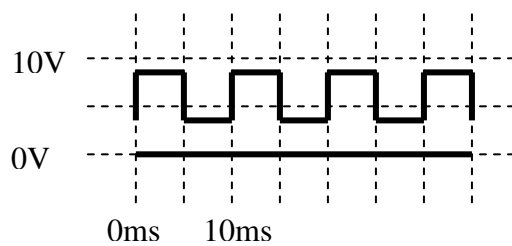

SIGNAL @ Segment (On)

Segment Ausnutzung

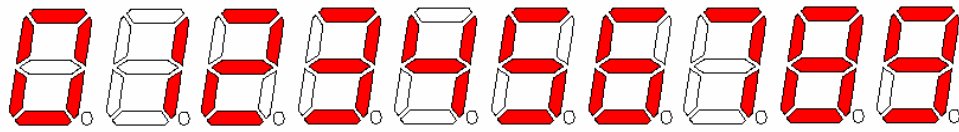

NORM

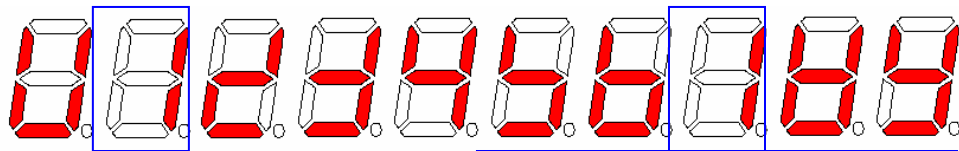

-A : 1,7

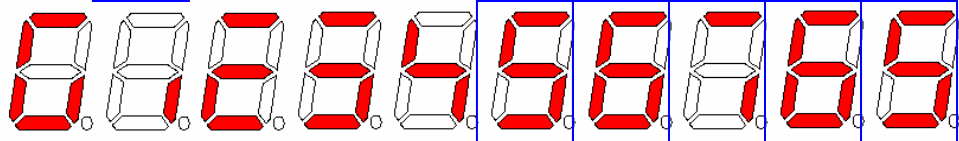

-B : 6,8 5,9

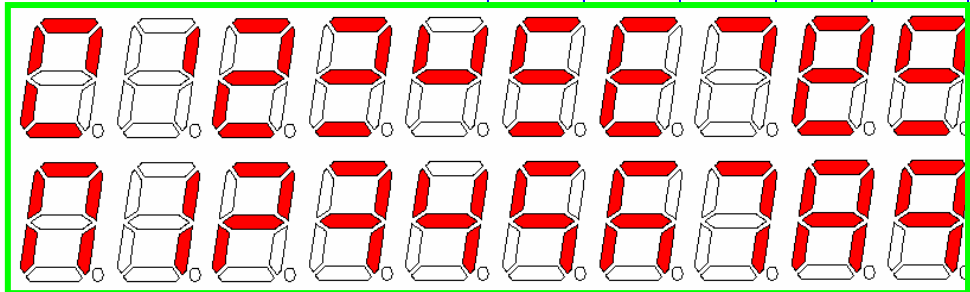

-C : OK

-D : OK

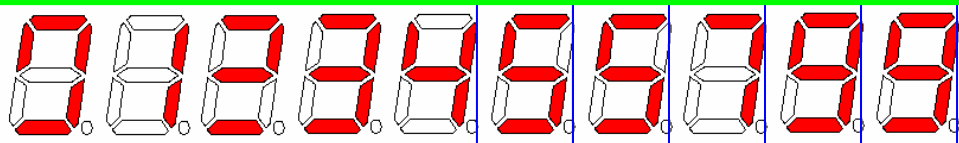

-E : 5,6 8,9

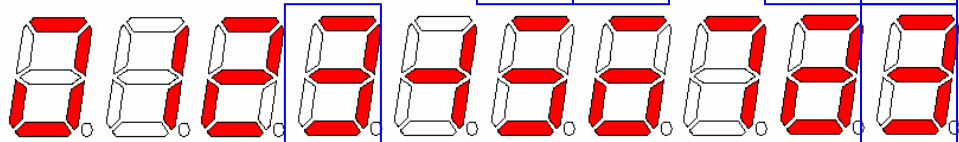

-F : 3,9

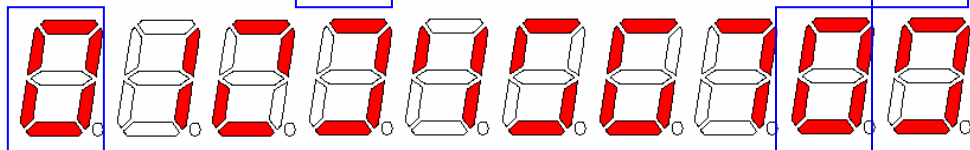

-G : 0,8

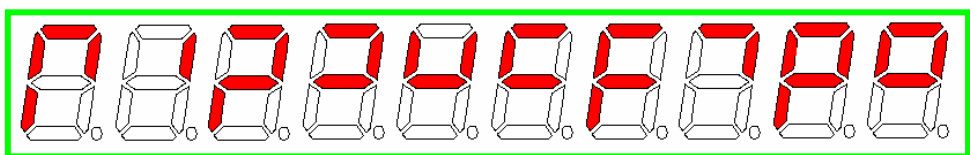

-C-D : OK

Multimeter Chip benutze Pins

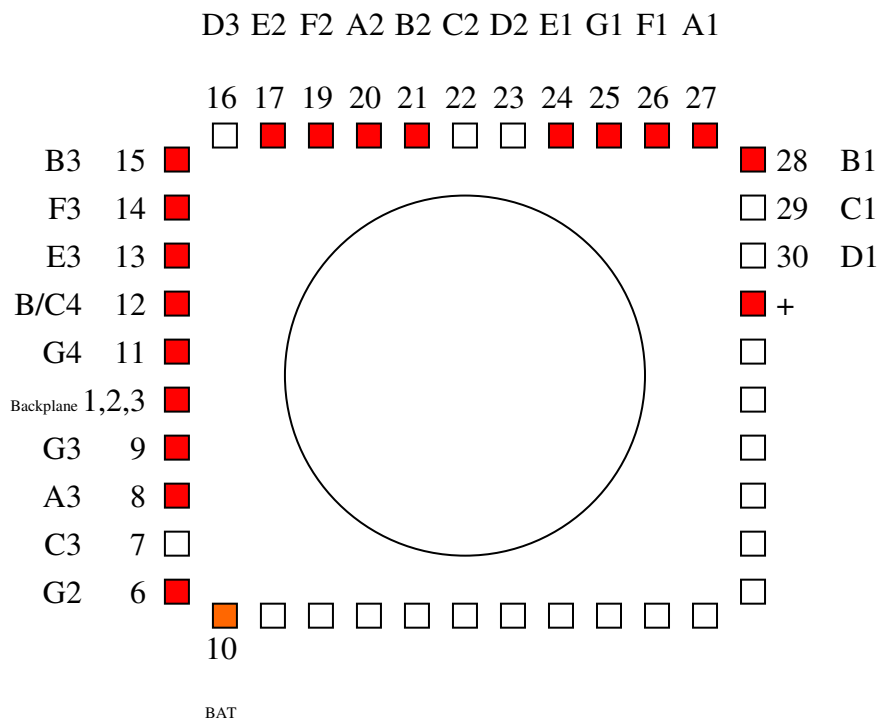

Atmega Pinnig to Display

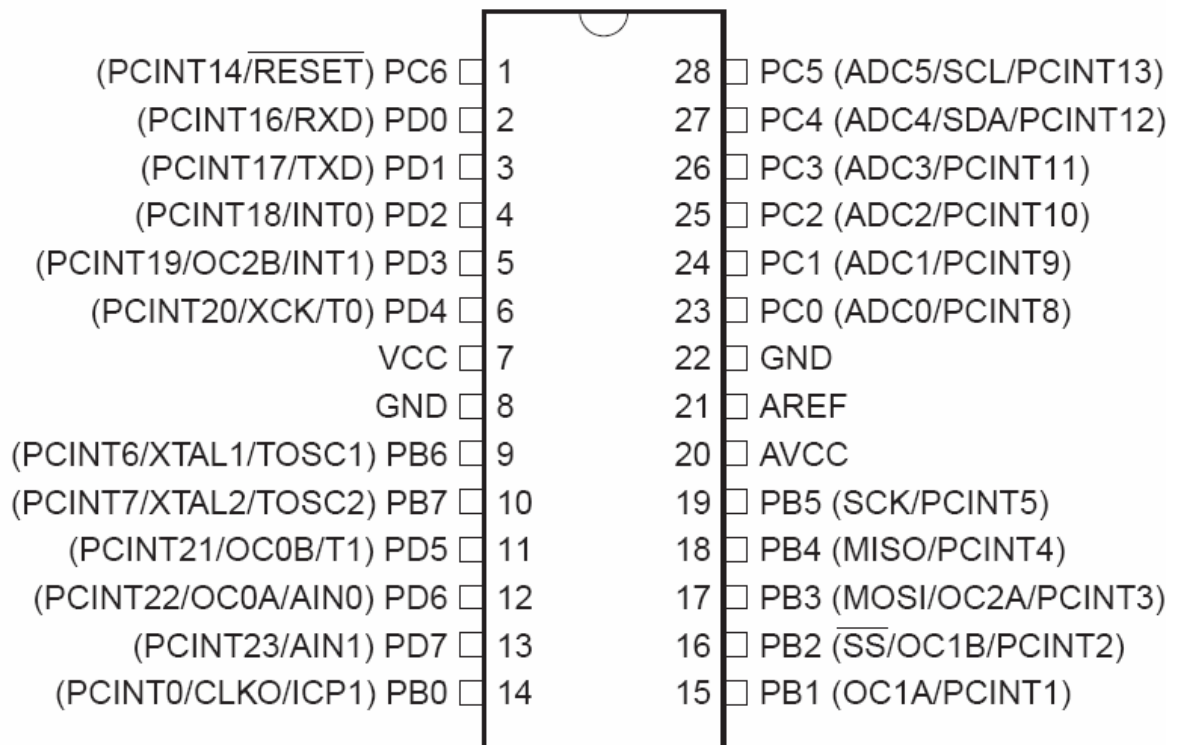
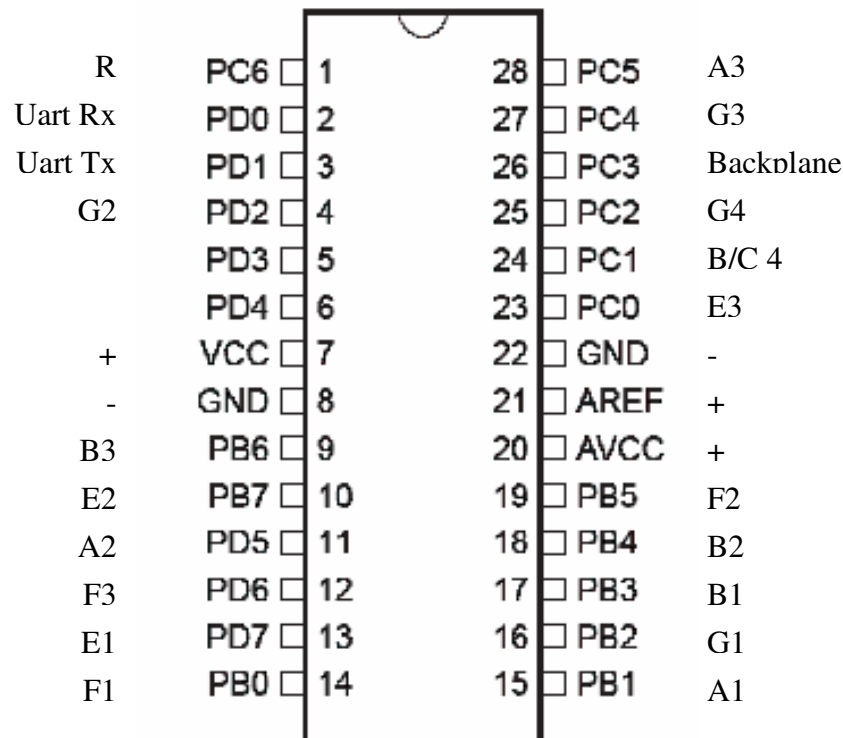

7 Segment Dekodierung

GFEBA		
01111	0x0f	0
00010	0x02	1
10111	0x17	2
10011	0x13	3
11010	0x1A	4
11001	0x19	5
11101	0x1D	6
00011	0x03	7
11111	0x1F	8
11011	0x1B	9

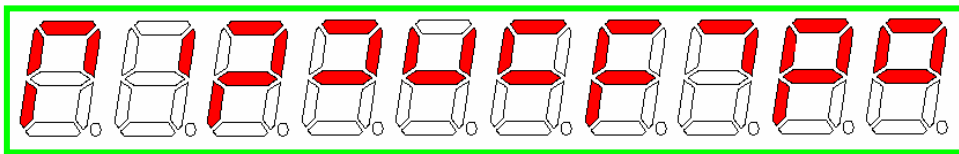

Zusätzliche Fälle:

GFEBA		
00000	0x00	space
xxxxx	n.d.	-

Erste tests 25ohm

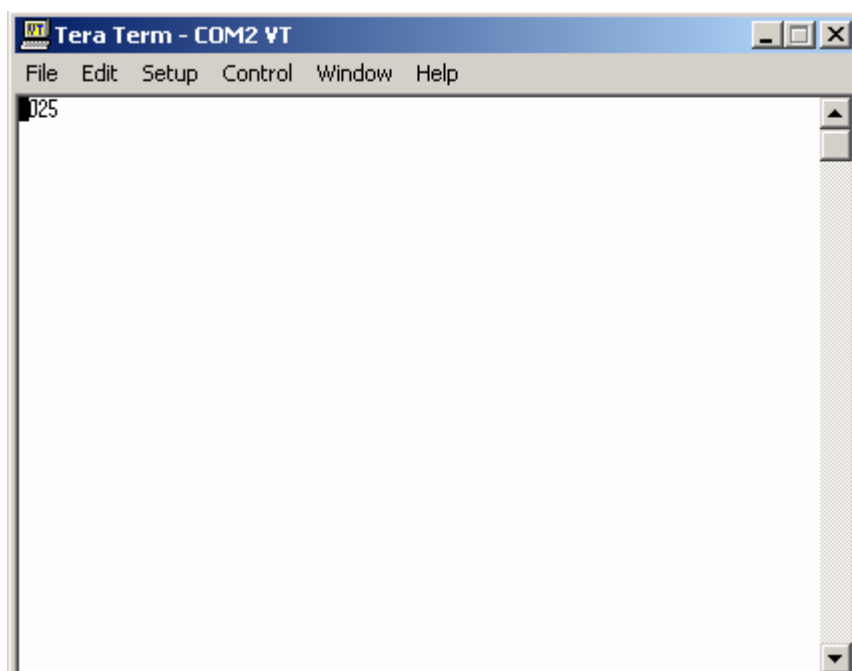

Aufbau

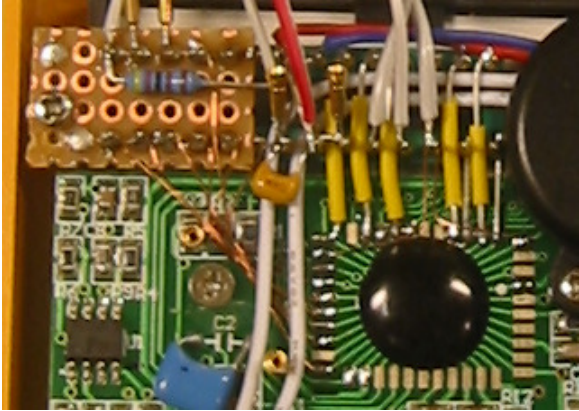
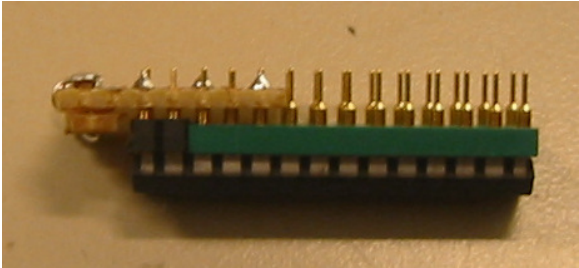
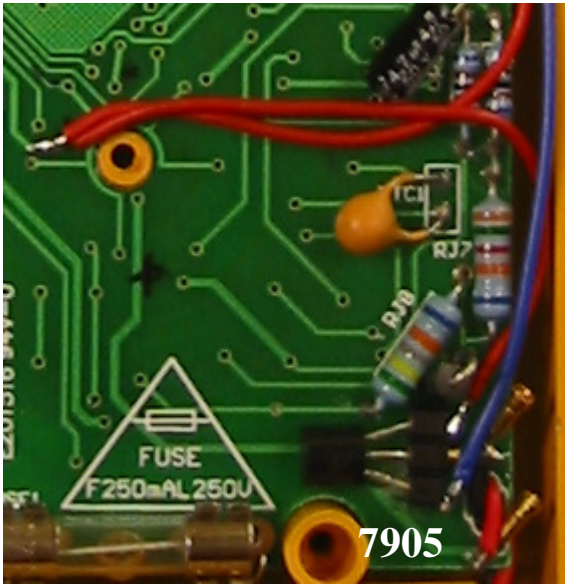
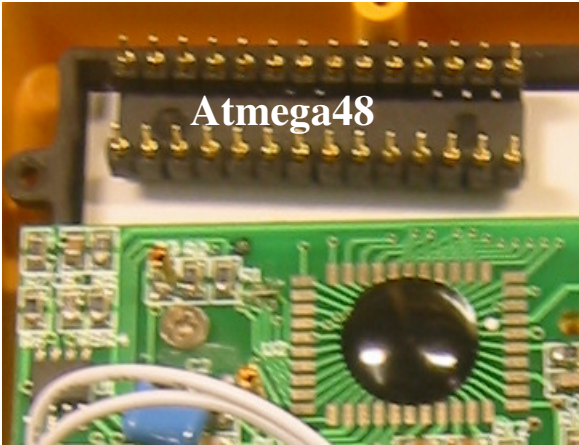

Erster Testaufbau

Materialiste Reichelt Konfiguration 1

Materialiste Reichelt Konfiguration 2

Materialiste Pollin

Materialiste Pollin Konfiguration 1

Materialiste Pollin Konfiguration 2

Konfiguration 1

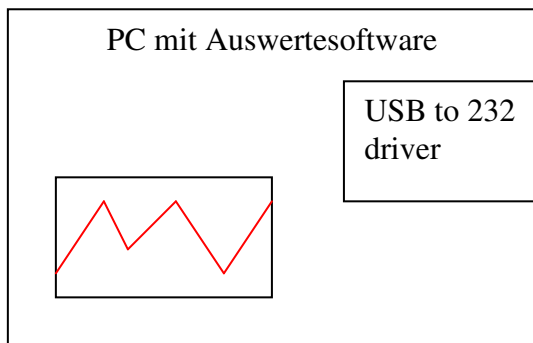
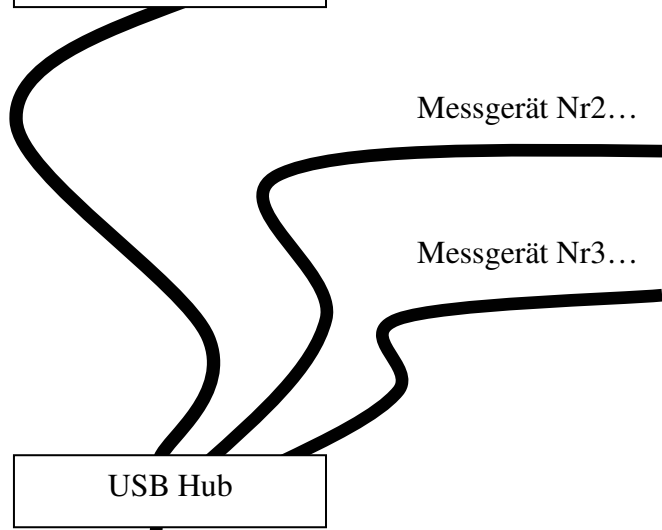
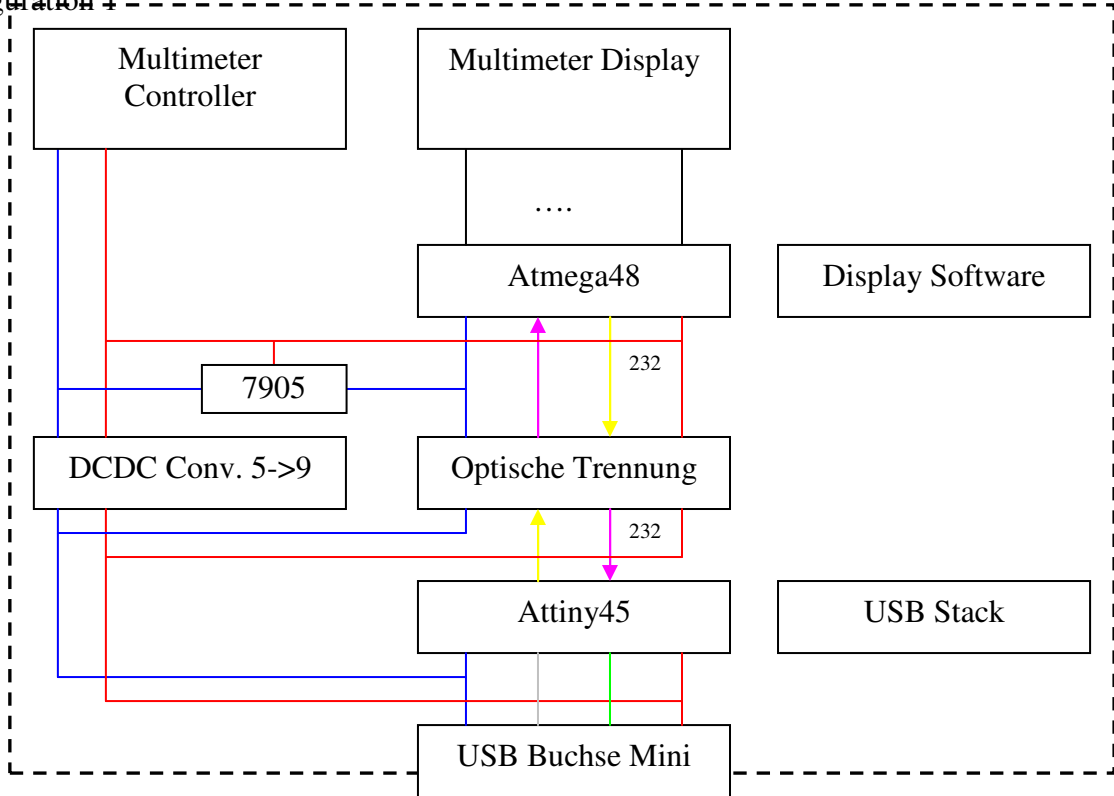

Konfiguration 2 (LOW COST) auch für mikrocontrolleranwendungen (Empfangseitig)

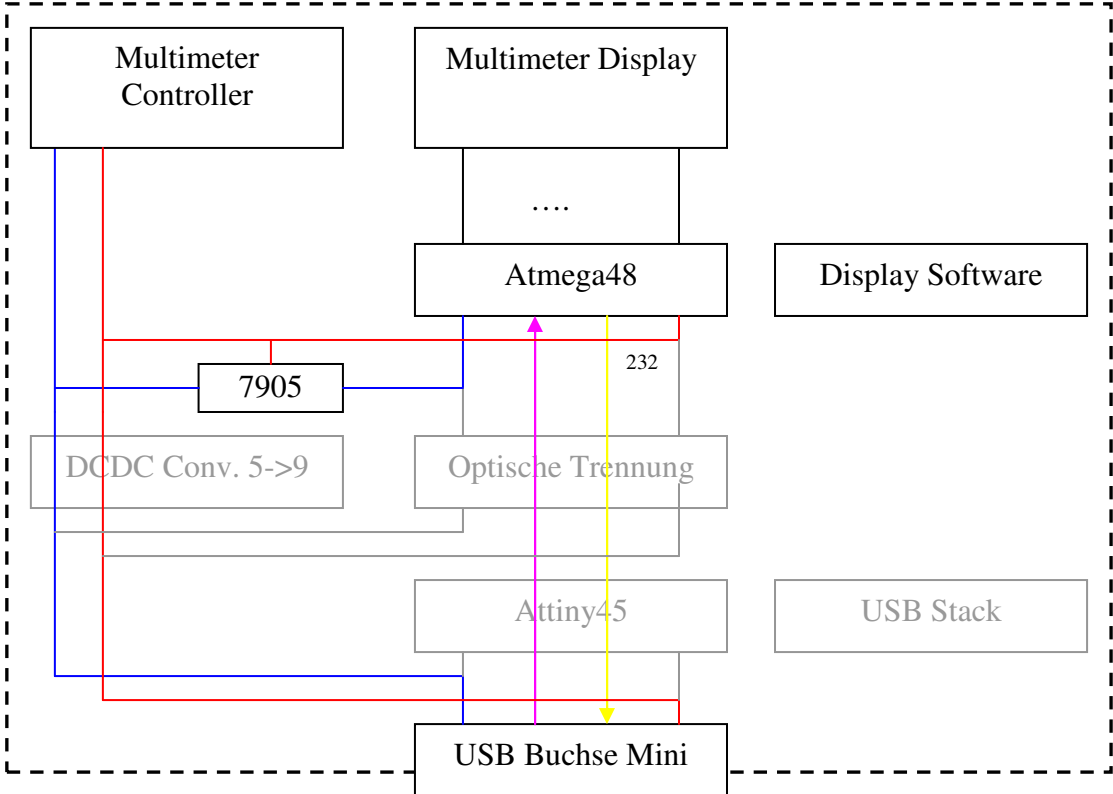

Platinenlayout

