

## Method to Reduce the Output Ripple & Noise of Power Supplies

The switching power supplies have the fundamental advantage of high efficiency i.e. low power dissipation when compared to linear voltage regulation. However, there exists an important consideration concerning the presence of ripple and noise at their outputs. If the ripple and noise are left unfiltered their levels may be sufficiently high to adversely affect other devices connected to the same power supply. Fortunately there exists methods to cost effectively reduce the impact of ripple and noise.

### Two noise sources

Input noise in a step-down DC/DC converter has two components. The first occurs at the fundamental switching frequency commonly referred to as ripple. The second noise component is associated with the very high frequency ringing that occurs during switching transitions

### Filtering for Typical Applications

For typical applications where ripple and noise need to be filtered but where they are not critical, a filtering capacitor may be added to the DC/DC output end and input end to reduce the noise and ripple. If the capacitance is too big, a startup problem might arise. To provide safe and reliable operation for every channel of output, see the external capacitor table for the recommended capacitance values.

Table 1 gives external capacitor values for a 1 watt DC /DC converter with single and a dual output.

It should also be noted that the inductance and the frequency of the “LC” filtering network should be staggered with the DC/DC frequency to avoid mutual interference (see Figure 1 for single and dual output).

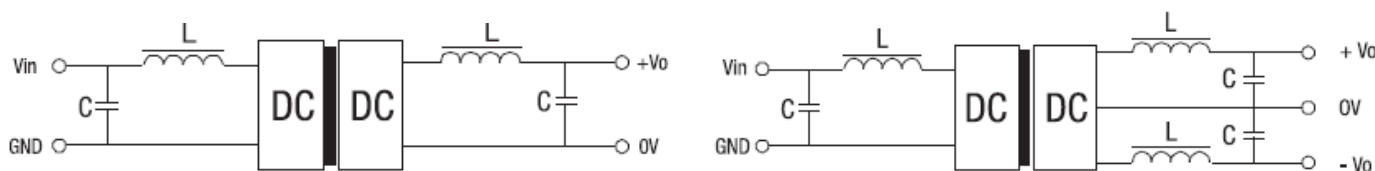

Figure 1

External Capacitor Table for Single Output			
Vin	External Capacitor	Vout	External Capacitor
5VDC	4.7 $\mu$ F	5VDC	10 $\mu$ F
12VDC	2.2 $\mu$ F	9VDC	4.7 $\mu$ F
24VDC	1 $\mu$ F	12VDC	2.2 $\mu$ F
--	--	15VDC	1 $\mu$ F

External Capacitor Table for Dual Output			
Vin	External Capacitor	Vout	External Capacitor
5VDC	4.7 $\mu$ F	5VDC	4.7 $\mu$ F
12VDC	2.2 $\mu$ F	9VDC	2.2 $\mu$ F
24VDC	1 $\mu$ F	12VDC	1 $\mu$ F
--	--	15VDC	0.47 $\mu$ F

Table 1

## Method to Reduce the Output Ripple & Noise of Power Supplies

### Filtering for Noise Sensitive Applications

In some applications there is a requirement for better ripple performance than the DC / DC converter can provide on its own. In these instances it is recommended that an external PI Filter be added to the converter's output.

The following description is intended as a guideline to design a simple LC filter. Other considerations such as component cost should also be evaluated.

Figure 2 shows a PI LC filter.

The first step is to choose an inductor with a current rating double to the maximum output current of the converter. A large value of inductor will require a large value of capacitor and the response of the filter will be slowed, so it is recommended to choose a small value inductor, typical value is 1  $\mu$ H.

For the minimum capacitor value use the following equation:

$(V_{\text{max ripple}}/V_{\text{converter ripple}}) = XC/(XC + XL)$ , where  $XC = 1/(2\pi fC)$ ,  $XL = 2\pi fL$ ,  $f$  = switching frequency of converter,  $C$  = capacitance,  $L$  = Inductance

### Example:

Converter ripple is 60mv  
Max allowable ripple is 10mV  
 $f = 500$  KHz  
 $L = 1\mu$ H

$$C_{\text{min}} = [(1-0.16)/0.16] \times [1/((2\pi f)^2 * L)]$$

$$C_{\text{min}} = 0.54\mu\text{F, use } 1\mu\text{F}$$

If  $V_{\text{out}} = 5\text{V}$ , then capacitor should be rated to 10V.

Figure 2 shows "ideal" components. A "real world" capacitor is modeled as a capacitor connected in series with a resistor. The resistance is known as an equivalent series resistor (ESR) The ESR of the cap should be as low as possible without making the converter unstable.

The resistor in Figure 2 is for damping purposes, it is used to prevent the filter from creating a short circuit at resonance and triggering the converters overload protection circuit.

The damping Resistor (R) value should be the same as the impedance of the inductor

$$R = XL = 2\pi fL$$

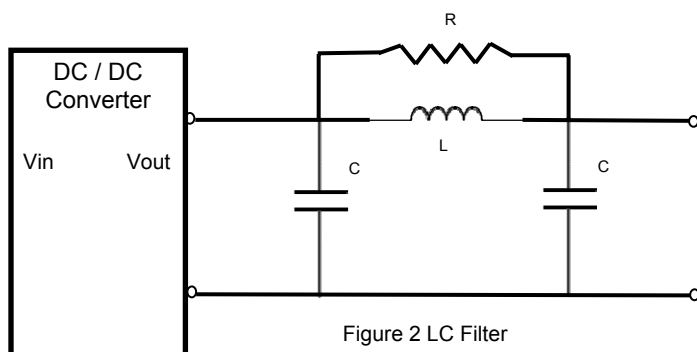

## Method to Reduce the Output Ripple & Noise of Power Supplies

### Electromagnetic Interference Filtering (EMI)

DC / DC converters employing high-frequency switching are highly efficient, however all switch mode DC / DC power converters generate EMI. Most DC / DC converters employ some sort of input and output filtering, however, designs that are required to comply with FCC and European agency's specifications will likely require external filtering.

In the United States the FCC requires equipment operating in home use to comply with the strictest standards (Class B).

Figure 3 show a typical topology of a single package integrated circuit EMI filter. The EMI filter provides sufficient attenuation to comply with FCC Class B levels.

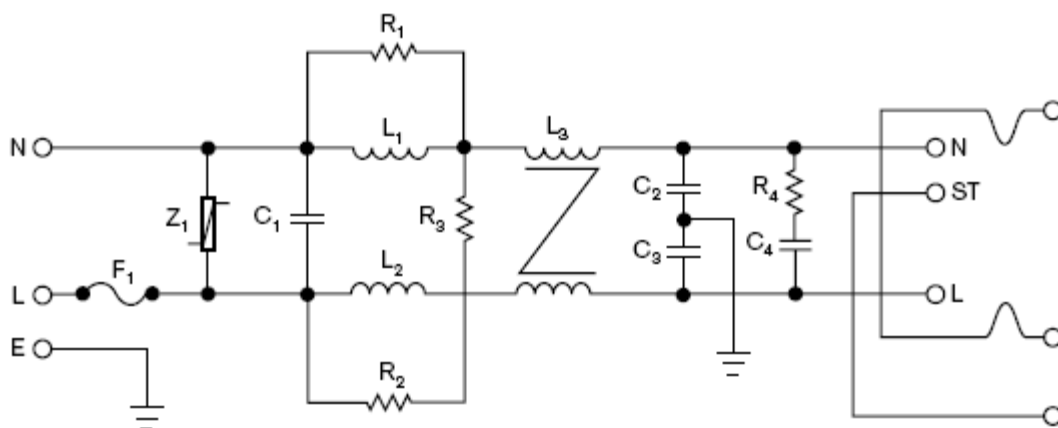

Figure 3

**Notes:** Information furnished is believed to be accurate and reliable. However, Aimtec Inc. assumes no responsibility for the consequences of use of such information nor for any infringement of patents or other rights of third parties which may result from its use. No license is granted by implication or otherwise under any patent or patent rights of Aimtec Inc. Specifications mentioned in this publication are subject to change without notice. This publication supersedes and replaces all information previously supplied. Aimtec Inc. Products are not authorized for use as critical components in life support devices or systems without express written approval of Aimtec Inc.

© 2006 Aimtec Inc. – All Rights Reserved