



LC 16.2 TREND SCREENKEYS

DATA SHEET

Article numbers

P125-1b and P125-1g



SK INTERFACES LTD.
SCREENKEYS DIVISION

Unit 11, Keypoint Business Park,
42 Rosemount Park Drive,
Ballycoolin Road
Dublin 11, Ireland.

Tel: +353-1-8855 075
Fax: +353-1-8855 095

St. Johanner Strasse 41-43,
66111 Saarbrücken,
Germany.

Tel: +0700-screenkey
Fax: +0700 1624 1624

Please visit our website www.SCREENKEYS.COM for additional information.

Important Notice

Warranty Disclaimer

SK INTERFACES LIMITED GRANTS NO WARRANTY WITH RESPECT TO THIS DATA SHEET, NEITHER EXPLICIT NOR IMPLIED, AND IT IS NOT LIABLE FOR DIRECT OR INDIRECT DAMAGES. SOME STATES DO NOT GRANT THE EXCLUSION OF INCIDENTAL OR CONSEQUENTIAL DAMAGES AND, THEREFORE, THIS STATEMENT MAY NOT BE VALID IN SUCH CASES.

Copyright Notice

© 2003 - Copyright SK Interfaces Limited. All rights reserved. No part of this publication may be copied, photocopied, reproduced, translated or reduced to any electronic medium or machine readable form without the expressed written consent from SK Interfaces Limited.

This data sheet has been produced with all due care. However, since errors cannot be excluded, SK Interfaces Limited does not grant any warranty or accept any legal responsibility or liability in any form for erroneous statements herein.

General Notice

This data sheet is intended for technically qualified personnel trained in the field of electronics.

The knowledge and technically correct implementation of the content of this data sheet are required for problem free installation and safe operation of the described product. Only qualified personnel has the required know how to implement the specifications given in this data sheet.

For clarity, not all details regarding the product or its implementation, installation, operation, or maintenance have been included. Should you require additional information, please contact SK Interfaces Limited or visit our website at www.screenkeys.com.

Contents

Important Notice.....	2
Warranty Disclaimer.....	2
Copyright Notice.....	2
General Notice.....	2
Contents.....	3
1. Technical Description.....	4
1.1. Applications.....	4
1.2. Advantages.....	4
2. Dimensions.....	5
3. Display-Module.....	6
3.1. Display Module Specifications.....	6
4. Liquid Crystal Display.....	6
4.1. Liquid Crystal Display Specifications.....	7
5. Key Switch.....	7
6. Control.....	8
6.1. Parity Bit.....	9
6.2. Timing Bit.....	9
6.3. Data Byte Format.....	10
6.4. Background Lighting.....	10
6.5. Bit Mapping.....	11
6.6. MUX Register.....	12
6.7. Frequency Value Table.....	12
6.8. Programming Example.....	14
7. Application.....	15
7.1. Application Control of ScreenKeys via Shift Register.....	15
7.2. Control of Multiple ScreenKeys.....	16
8. Parts Drawing.....	17
9. Technical Specifications.....	18
10. UL Material Listings.....	18
11. Order Information.....	18
Contact Information.....	18

1. Technical Description

The LC16.2 Trend ScreenKey is a push-button keyswitch with built-in graphics display. A liquid crystal display is integrated within the key, with a resolution of 32*16 pixels with an internal display controller. Every pixel can be turned on or off individually, allowing the display of text or graphics. To control the display only a clock and data line (synchronous data transfer) as well as V_{CC} and GND are required.

Furthermore, background lighting is integrated in the display, which allows the display to be read in dark operating environments. An additional advantage of the background lighting is the ability to notify the operator. Different operating conditions may be displayed in different colors. The standard background light (green) can be changed to bright green, bright red, dark red, orange, or dark orange, red-orange or green-orange (see note below).

The LC16.2 Trend ScreenKey is designed for printed circuit board assembly.

1.1. Applications

The multi-function LC16.2 Trend ScreenKey, with its LCD display and multi-colored backlighting, is used in standard applications of multifunctional control panels as well as additional areas, such as

- Industrial controls
- Studio and audio equipment
- Point-of-sale, point-of-information
- Medical devices
- etc.

1.2. Advantages

The advantages of this ScreenKeys are the simple hardware and software control of the LCD display. This allows for the easy integration of the switch into products without extensive development efforts.

- Only 4 leads for display control
- No external display controller required
- Greater signal effectiveness through multi-colored background lighting.
- Display text, graphics or animation with 32*16 pixel resolution.
- Fast data transmission due to high transmission rates (up to 4 MBaud)
- Display refresh carried out from within the display
- Optimal illumination with 8 integrated LED's
- Positive feedback that function has been executed
- Intuitive user guidance through menu systems

Note:

There can be slight differences in emitted color frequencies with LED technology. This can be particularly noticeable when using *orange* backlighting on adjacent keys, as orange is produced by mixing red and green LED's together. It is recommended that the use of *orange* backlighting should be restricted for short duration alarm or notification messages.

2. Dimensions

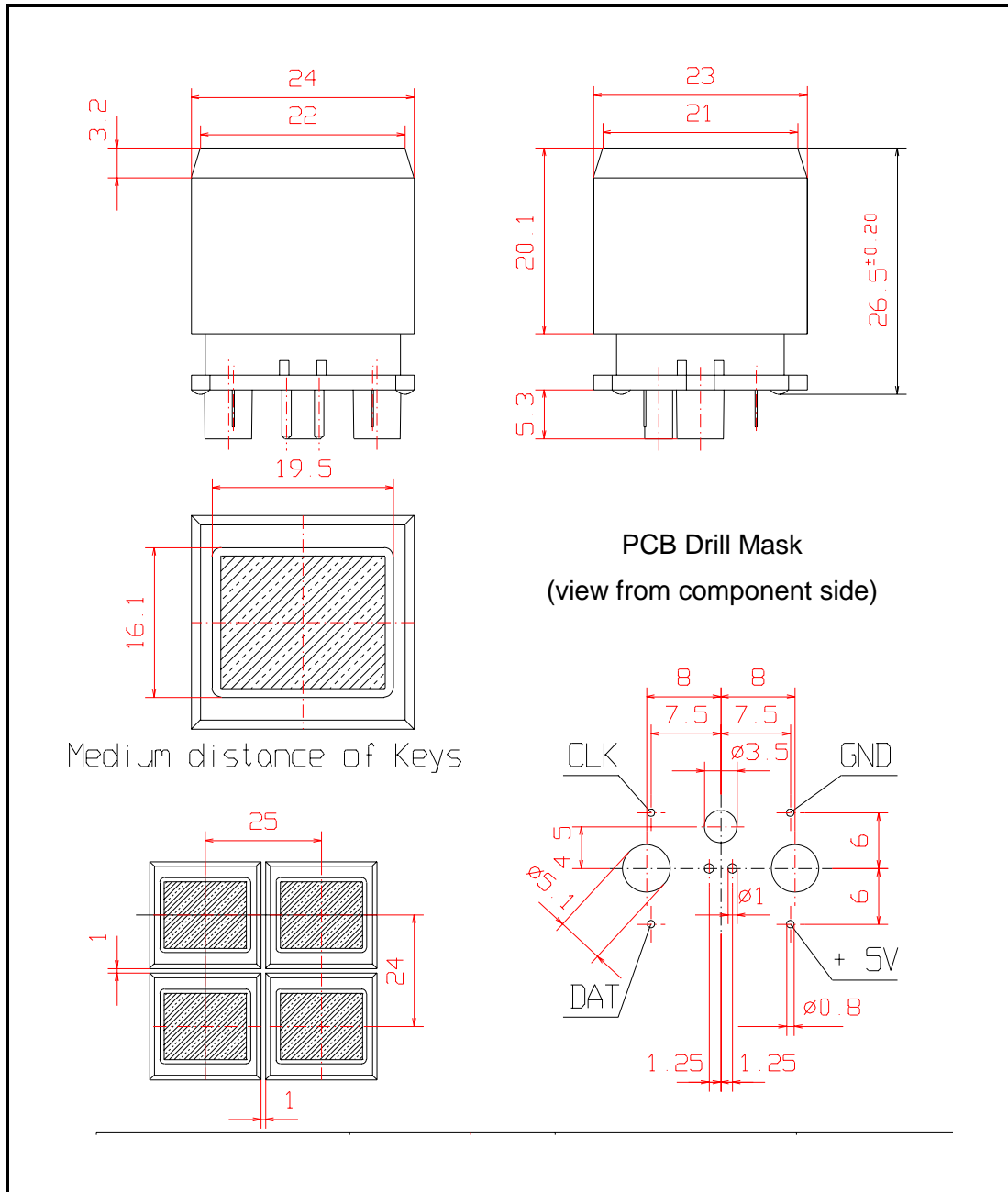

Drawing 2.: Dimensions of LC16.2 Trend ScreenKey in mm. Drill mask view from component side.

Note: For assembly in a keyswitch array, the distance between the displays should be at least 1 mm.

3. Display-Module

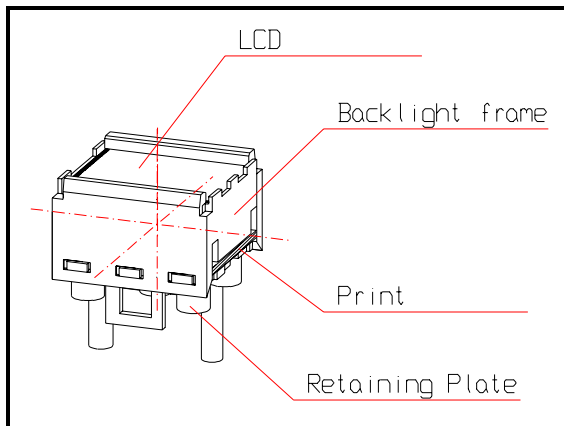

Drawing 3.: LCD Module LC16.2 Trend.

3.1. Display Module Specifications

Description	Values
Connections	4 (V_{CC} , GND, CLK, Data)
Current consumption	max 87 mA
LCD Driver	integrated in ASIC
Pixel Area	14.74 mm x 10.52 mm
Viewing Angle	horizontal 100 degrees vertical 120 degrees

4. Liquid Crystal Display

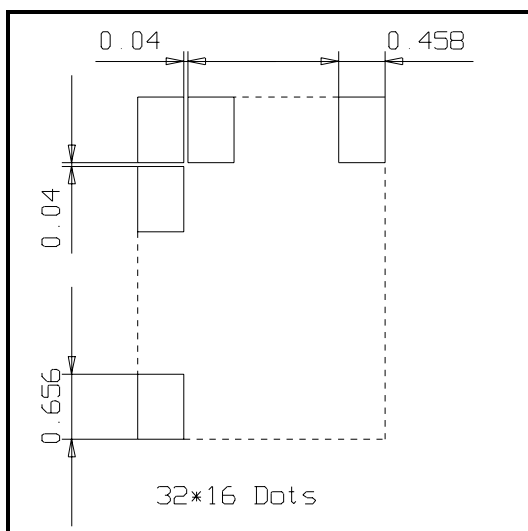

Drawing 4: LCD - display area / pixel size in mm.

4.1. Liquid Crystal Display Specifications

Description	Values
Response Time	200 ms
Refresh Rate	64 Hz
Current Consumption	10 μ A
Reflector	transmissiv
Contact	elastomers (conductive rubber)
LCD Glass	STN, yellow-green
Pixel Matrix	32 columns x 16 rows
Pixel Size	0.46 mm x 0.66 mm
Orientation	6 o'clock
Operating Temperature	0° - +40° Celsius
Storage Temperature	-20° - +60° Celsius
Humidity Storage/Operating	max. 80% relative at 40° Celsius
Life Cycle	5 – 7 years (life cycle from date of manufacture and may be reduced by exposure to excess humidity, temperature and ultra-violet light)

5. Key Switch

Description	Values
Circuit Voltage	12 Volt +10%
Circuit Current	5 mA max.
Volume Resistance	< 200 Ohm
Insulating Resistance	> 100 MOhm
Contact bounce time	< 20 ms
Key Travel	2.4 mm
Operating Force	1.0 to 1.4 Newton
Durability	1 Million operations
Decoupling Diode	not present

6. Control

The LC16.2 Trend ScreenKey is controlled by a synchronous serial data transmission. This controls the multiplex frequency, the background lighting and the 32*16 pixel matrix in the display.

The clock is used for the internal control of the ASIC (data transfer, LCD refresh, etc.) and must be applied constantly.

Note: Applying power to the LCD when no clock is present may damage the LCD

The clock frequency can be between 50 kHz and 4 MHz. The minimum LCD repeat frequency is about 64 Hz. In order to set this rate, the frequency register (internal address 0xEE) has to be loaded with a value from frequency value table (see 6.7.).

Note: You may chose a value which is lower in order to increase the contrast ratio, but the given argument in the frequency value table **may not be exceeded at any time**

To change the background colors, the corresponding value in the color register (internal address 0xED) must be changed. The values to set the colors are given in table 6.4.

Furthermore, the MUX register (internal addresses 0xEF - 0xF0) must be loaded with the values from table 6.6. The values in the MUX register are only valid if the value of the lowest 3 bits in register 0xEF are the inverse to the value of the lowest 3 bits in register 0xFF.

Starting at the internal addresses 0x80 are the pixel data values as per table 6.5.

The LC16.2 Trend-switch is addressed by transmitting a start-byte (always 0x00) on the serial line. After the start-byte, one of the following commands is expected:

Data	Description	Data Size
Command 0x80	to type pixel data into RAM.	max. 64 bytes
Command 0xED	to type color value into register.	1 byte
Command 0xEE	to type in frequency value into register	1 byte
Command 0xEF	to set MUX register	2 bytes
Command 0xAA	end byte	0 bytes

The data bytes follow the command, up to a maximum of 64 bytes for command 0x80, or otherwise one or two bytes per command. After the data bytes follows the end byte command 0xAA

Note: The order Start Byte, Command Byte, Data Byte and End Byte must be adhered to. Since the data transfer to the LC16.2 Trend ScreenKey is unidirectional, no values can be read from the display.

The Frequency and MUX registers should be written at least once after each Power On Reset (POR).

If the LC16.2 Trend ScreenKey is loaded with values other than the ones given in the tables in this data sheet, the display may be destroyed

6.1. Parity Bit

A parity bit sent after every byte provides the differentiation between start byte, command and data bytes. The following assignments are valid:

Bytes	Parity
Start byte	even
Command byte	odd
Data bytes	odd
End byte	even

Even Parity :

The number of 1 bits in the byte should be supplied to even.

Example: 00000000 Byte, Parity Bit = 0
 00110111 Byte, Parity Bit = 1

Odd Parity :

The number of 1 bits in the byte should be supplied to odd.

Example: 00000000 Byte, Parity Bit = 1
 00110111 Byte, Parity Bit = 0

Note: The parity bit is not used to differentiate between Start/End Byte and the Command/Data Bytes and is not used for security purposes.

6.2. Timing Bit

For serial transmission of data to the display, the following conditions must be adhered to.

- Clock frequency max F_{max} 4 MHz
- Clock frequency min F_{min} 50 kHz
- Clock phase low max T_{cpl} 20 μ s
- Clock phase low min T_{cpl} 125 ns
- Clock phase high max T_{cph} 20 μ s
- Clock phase high min T_{cph} 125 ns
- Hold data min T_{hold} 10 ns
- Setup data min T_{su} 40 ns

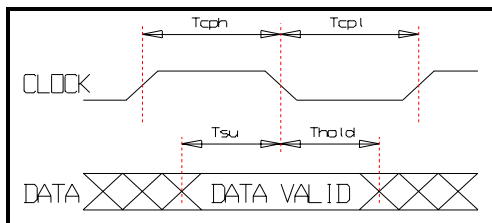

Drawing 6.2: Timing diagram

6.3. Data Byte Format

12 bits are required for the transmission of a byte.

- Start bit low SA
- Data bit low / high b0 - b7 (LSB first, MSB last)
- Parity bit low / high Pb
- 2 Stop bits high SE

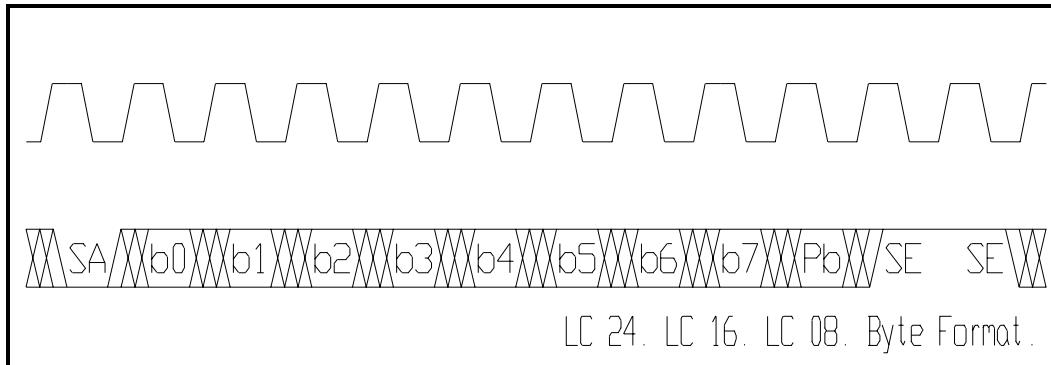

Drawing 6.3: Byte format

6.4. Background Lighting

	B7	B6	B5	B4	B3	B2	B1	B0
Color	red	red	green	green	red	red	green	green
Function (0/1)	dark / bright	dark / bright	dark / bright	dark / bright	off / on	off / on	off / on	off / on

Combinations of red and green are possible by setting the corresponding bits in the color register (0xED).

The following table shows some possible values for backlighting colors:

Color	HEX Value	Binary Value
off	0x00	00000000
dark green	0x03	00000011
bright green	0x33	00110011
dark red	0x0C	00001100
bright red	0xCC	11001100
dark orange	0x0F	00001111
bright orange	0xFF	11111111
greenish orange	0x3F	00111111
reddish orange	0xCF	11001111

Table 6.4: Backlighting values for register 0xED

Note: Due to the variations in LEDs and the bonding material, color and brightness variations in the LC Trend ScreenKeys cannot be eliminated. In order to provide our customers with consistent quality of switches, the ScreenKeys Division has developed an electronic color and brightness measurement system.

*For further details, please refer to the **Color Selection Chart** available for download at*

www.SCREENKEYS.COM

6.5. Bit Mapping

Each bit in the data stream corresponds to a pixel in the display area. A 1-bit represents a black pixel, a 0-bit a light pixel. The allocation is shown in the following table. The upper line is the Byte number; the lower line shows the corresponding bits per pixel.

B00	b0 b1 b2 b3	b4 b5 b6 b7	B01	b0 b1 b2 b3	b4 b5 b6 b7	B02	b0 b1 b2 b3	b4 b5 b6 b7	B03	b0 b1 b2 b3	b4 b5 b6 b7
B04	b0 b1 b2 b3	b4 b5 b6 b7	B05	b0 b1 b2 b3	b4 b5 b6 b7	B06	b0 b1 b2 b3	b4 b5 b6 b7	B07	b0 b1 b2 b3	b4 b5 b6 b7
B08	b0 b1 b2 b3	b4 b5 b6 b7	B09	b0 b1 b2 b3	b4 b5 b6 b7	B10	b0 b1 b2 b3	b4 b5 b6 b7	B11	b0 b1 b2 b3	b4 b5 b6 b7
B12	b0 b1 b2 b3	b4 b5 b6 b7	B13	b0 b1 b2 b3	b4 b5 b6 b7	B14	b0 b1 b2 b3	b4 b5 b6 b7	B15	b0 b1 b2 b3	b4 b5 b6 b7
B16	b0 b1 b2 b3	b4 b5 b6 b7	B17	b0 b1 b2 b3	b4 b5 b6 b7	B18	b0 b1 b2 b3	b4 b5 b6 b7	B19	b0 b1 b2 b3	b4 b5 b6 b7
B20	b0 b1 b2 b3	b4 b5 b6 b7	B21	b0 b1 b2 b3	b4 b5 b6 b7	B22	b0 b1 b2 b3	b4 b5 b6 b7	B23	b0 b1 b2 b3	b4 b5 b6 b7
B24	b0 b1 b2 b3	b4 b5 b6 b7	B25	b0 b1 b2 b3	b4 b5 b6 b7	B26	b0 b1 b2 b3	b4 b5 b6 b7	B27	b0 b1 b2 b3	b4 b5 b6 b7
B28	b0 b1 b2 b3	b4 b5 b6 b7	B29	b0 b1 b2 b3	b4 b5 b6 b7	B30	b0 b1 b2 b3	b4 b5 b6 b7	B31	b0 b1 b2 b3	b4 b5 b6 b7
B32	b0 b1 b2 b3	b4 b5 b6 b7	B33	b0 b1 b2 b3	b4 b5 b6 b7	B34	b0 b1 b2 b3	b4 b5 b6 b7	B35	b0 b1 b2 b3	b4 b5 b6 b7
B36	b0 b1 b2 b3	b4 b5 b6 b7	B37	b0 b1 b2 b3	b4 b5 b6 b7	B38	b0 b1 b2 b3	b4 b5 b6 b7	B39	b0 b1 b2 b3	b4 b5 b6 b7
B40	b0 b1 b2 b3	b4 b5 b6 b7	B41	b0 b1 b2 b3	b4 b5 b6 b7	B42	b0 b1 b2 b3	b4 b5 b6 b7	B43	b0 b1 b2 b3	b4 b5 b6 b7
B44	b0 b1 b2 b3	b4 b5 b6 b7	B45	b0 b1 b2 b3	b4 b5 b6 b7	B46	b0 b1 b2 b3	b4 b5 b6 b7	B47	b0 b1 b2 b3	b4 b5 b6 b7
B48	b0 b1 b2 b3	b4 b5 b6 b7	B49	b0 b1 b2 b3	b4 b5 b6 b7	B50	b0 b1 b2 b3	b4 b5 b6 b7	B51	b0 b1 b2 b3	b4 b5 b6 b7
B52	b0 b1 b2 b3	b4 b5 b6 b7	B53	b0 b1 b2 b3	b4 b5 b6 b7	B54	b0 b1 b2 b3	b4 b5 b6 b7	B55	b0 b1 b2 b3	b4 b5 b6 b7
B56	b0 b1 b2 b3	b4 b5 b6 b7	B57	b0 b1 b2 b3	b4 b5 b6 b7	B58	b0 b1 b2 b3	b4 b5 b6 b7	B59	b0 b1 b2 b3	b4 b5 b6 b7
B60	b0 b1 b2 b3	b4 b5 b6 b7	B61	b0 b1 b2 b3	b4 b5 b6 b7	B62	b0 b1 b2 b3	b4 b5 b6 b7	B63	b0 b1 b2 b3	b4 b5 b6 b7
left half of display						right half of display					

Table 6.5: Bit Mapping

6.6. MUX Register

The MUX register controls the internal frequency divider for the control of the LCD and must be programmed with the values in table 6.7 to achieve optimum LCD contrast. Otherwise, loss of contrast or scrambled displays may result.

Description	Address	Value
MUX	0xEF	0x02
	0xF0	0x05

Table 6.6: MUX register

6.7. Frequency Value Table

The clock frequency can be set in a range from 50 kHz to 4 MHz. In the LC16.2 Trend ScreenKey, the clock frequency will be divided down by a factor, which is set through the frequency register (0xEE). The aim is to set the LCD repeat frequency at a value of at least 64 Hz. In the table below, the left column indicates the calculated clock frequency. In the right hand column the appropriate maximum data value to be entered in the frequency register is listed.

Note: The value given is the maximum value. It is possible to enter up to 75 % lower frequency values. The best contrast will be found at values of less than 50% of the maximum allowed value for operating temperatures at about 21 degrees Celsius.

Example: The clock frequency is 500 kHz, the corresponding value in the table is 0x68. Any value between the frequencies 125 kHz (value 0x28) to 500 kHz (value 0x68) may be entered.

Clock	Reg. 0xEE
49,92kHz	00
53,04kHz	02
56,16kHz	04
59,28kHz	06
62,40kHz	08
65,52kHz	0A
68,64kHz	0C
71,76kHz	0E
74,88kHz	10
78,00kHz	12
81,12kHz	14
84,24kHz	16
87,36kHz	18
90,48kHz	1A
93,60kHz	1C
96,72kHz	1E
99,84kHz	20
106,1kHz	22
112,3kHz	24
118,6kHz	26
124,8kHz	28
131,0kHz	2A
137,3kHz	2C
143,5kHz	2E
149,8kHz	30
156,0kHz	32
162,2kHz	34
168,5kHz	36
174,7kHz	38
181,0kHz	3A
187,2kHz	3C
193,4kHz	3E
199,7kHz	40
212,2kHz	42
224,6kHz	44

Clock	Reg. 0xEE
237,1kHz	46
249,6kHz	48
262,1kHz	4A
274,6kHz	4C
287,0kHz	4E
299,5kHz	50
312,0kHz	52
324,5kHz	54
337,0kHz	56
349,4kHz	58
361,9kHz	5A
374,4kHz	5C
386,9kHz	5E
399,4kHz	60
424,3kHz	62
449,3kHz	64
474,2kHz	66
499,2kHz	68
524,2kHz	6A
549,1kHz	6C
574,1kHz	6E
599,0kHz	70
624,0kHz	72
649,0kHz	74
673,9kHz	76
698,9kHz	78
723,8kHz	7A
748,8kHz	7C
773,8kHz	7E
798,7kHz	80
848,6kHz	82
898,6kHz	84
948,5kHz	86
998,4kHz	88
1,048MHz	8A

Clock	Reg. 0xEE
1,098MHz	8C
1,148MHz	8E
1,198MHz	90
1,248MHz	92
1,298MHz	94
1,348MHz	96
1,398MHz	98
1,448MHz	9A
1,498MHz	9C
1,548MHz	9E
1,597MHz	A0
1,697MHz	A2
1,797MHz	A4
1,897MHz	A6
1,997MHz	A8
2,097MHz	AA
2,196MHz	AC
2,296MHz	AE
2,396MHz	B0
2,496MHz	B2
2,596MHz	B4
2,696MHz	B6
2,796MHz	B8
2,895MHz	BA
2,995MHz	BC
3,095MHz	BE
3,195MHz	C0
3,395MHz	C2
3,594MHz	C4
3,794MHz	C6
4,000 MHz	C8

7. Application

7.1. Application Control of ScreenKeys via Shift Register

A ScreenKey is connected to a microprocessor bus via 2 shift registers. The microprocessor provides the signals for D0 - D7, A0, not CS and CLK are required.

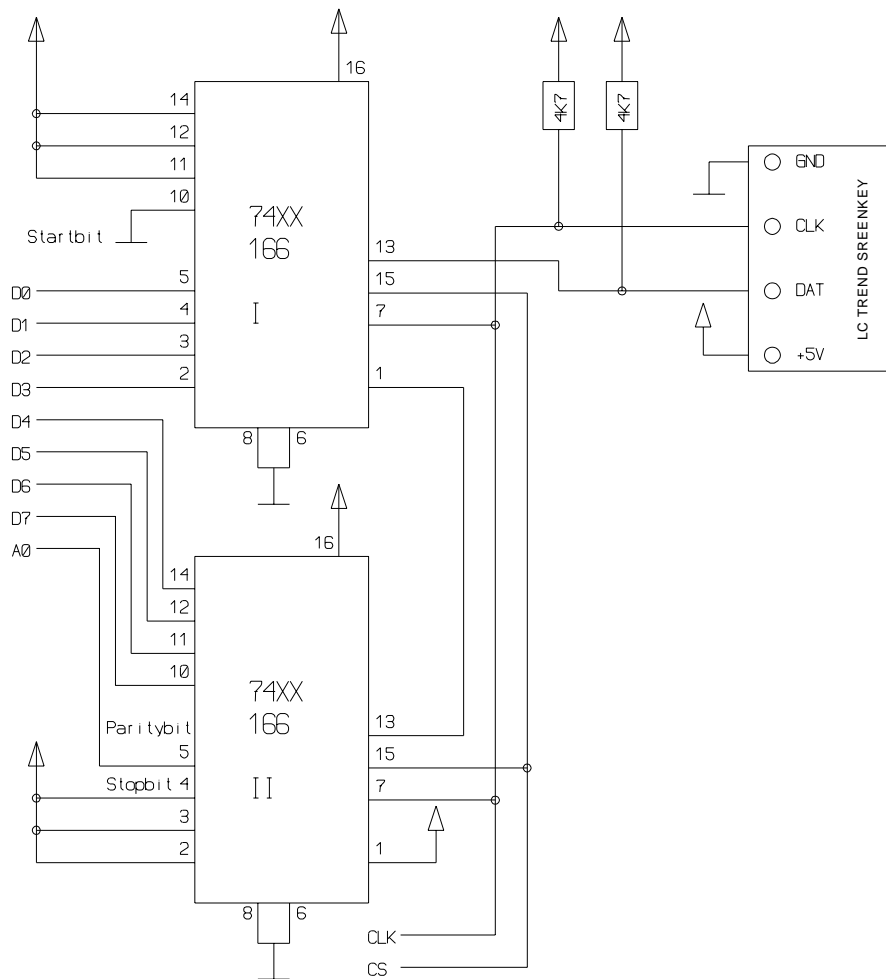

Drawing 7.1.: control parallel / serial.

Note: The data line must be set to high when inactive (no data transmission) to avoid erroneous data transfers.

7.2. Control of Multiple ScreenKeys

To control several ScreenKey, the data stream is switched through via a decoding circuit to a single switch. The other keys receive a high signal, which produces stop bits. The decoding can also be used for the switch decoding and, therefore, does not cause additional costs.

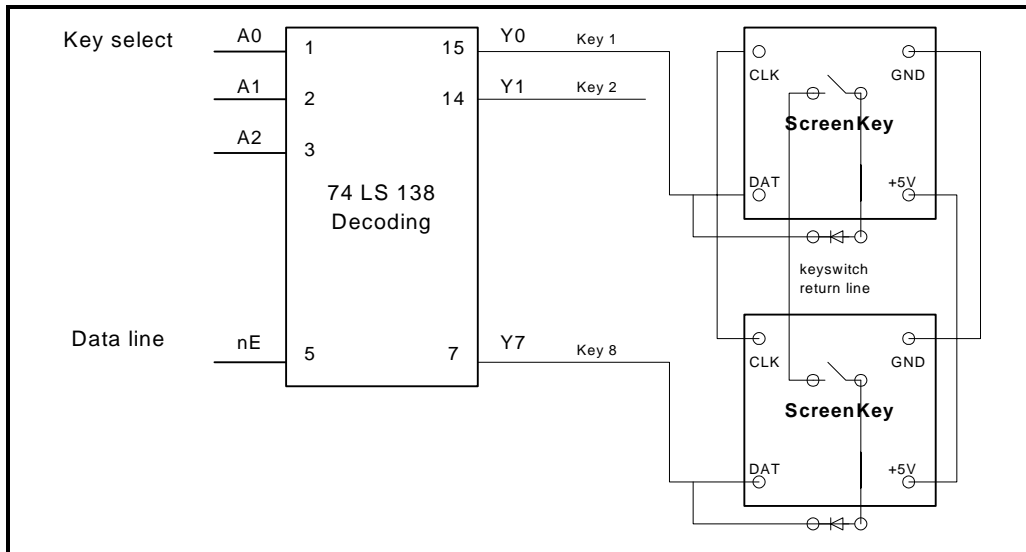

Drawing 7.2.: Decoding circuit LC Trend ScreenKey

Note: Due to the input capacitance of the LC Trend ScreenKeys, a maximum of 10 LC Trend ScreenKeys may be connected to one clock line (TTL output). If more than 10 LC Trend Keys are connected, data transfer errors may result.

8. Parts Drawing

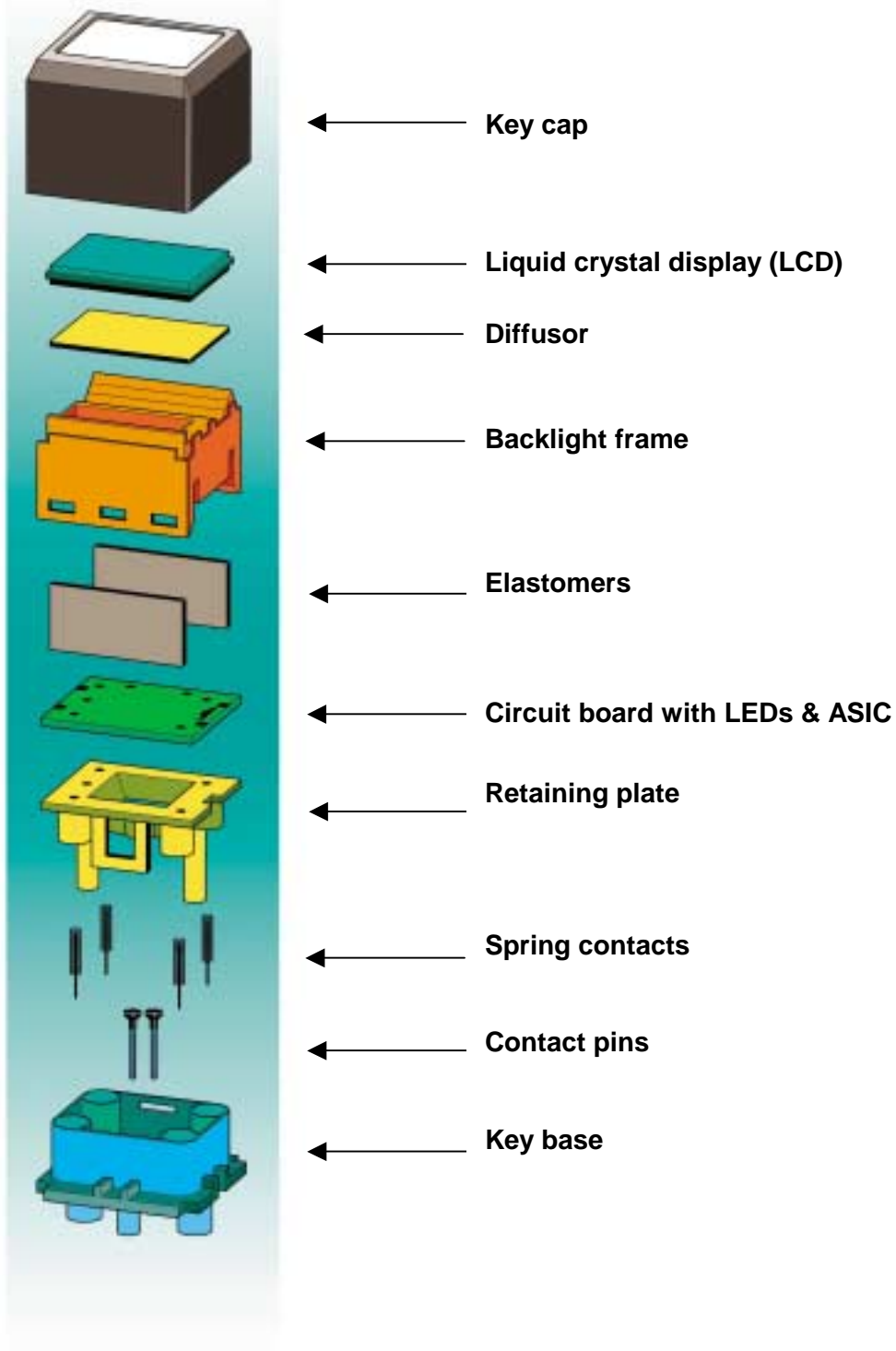

9. Technical Specifications

Description	Values
Dimensions (L x W x H)	24.0 x 23.0 x 26.5 mm +/- 0,2 mm
Screen Size (X x Y)	19.5 x 16.1 mm +/- 0.1 mm
Pixel Field Size (X x Y)	14.74 mm x 10.28mm
Pixel Size (X x Y)	0.46 x 0.66 mm
Pixel Matrix (X x Y)	32 x 16
Operating voltage	4.9 - 5.0 Volt (at operating temperature)
Current Consumption	max. 87 mA, typ. 43 mA
LED Backlighting	green, dark green, red, dark red, orange, dark orange, reddish-orange and greenish-orange
Operation Temperature	0° to 40° Celsius
Humidity	max. 80 % relative at 40° Celsius
Storage Temperature	-20° to +60° Celsius
Manually solderable at	350° Celsius, 3.5 seconds
Wave solderable at	260° Celsius, 10 seconds

10. UL Material Listings

Description	Material	UL Listing	UL File
Display window	MAKROLON 2805 PC	UL 94 V2	A070
Key cap	Novodur P2H-AT ABS	UL 94 HB	CO10
Backlight frame	HOSTAFORM POM	UL 94 HB	E42337A
Retaining plate	HOSTAFORM POM	UL 94 HB	E42337A
Key body	MAKROLON 2805 PC	UL 94 V2	A070
Diffusor	Polycarbonate	UL 94 V2	E41613

11. Order Information

Order No.	Description
P125-1b	LC16.2 Trend ScreenKey, black housing (RAL 9005)
P125-1g	LC16.2 Trend ScreenKey gray housing (RAL 7035)

Contact Information

For further information on LC Trend ScreenKeys, displays and other LCD Key Technology products, including technical documentation, datasheets, user manuals and software downloads, please visit our website at

www.SCREENKEYS.COM

or e-mail us at:

info@screenkeys.com



SK INTERFACES LTD.
SCREENKEYS DIVISION

Unit 11, Keypoint Business Park, 42 Rosemount Park Drive,
Ballycoolin Road, Dublin 11, Ireland.

Tel: +353-1-8855 075

Fax: +353-1-8855 095

St. Johanner Strasse 41-43, 66111 Saarbrücken, Germany.

Tel: +0700-screenkey

Fax: +0700-1624 1624