

EXAMINED BY :	EMERGING DISPLAY TECHNOLOGIES CORPORATION	FILE NO . CAS-0006821
Vincent Wu		ISSUE :MAR.09, 2012
APPROVED BY:		TOTAL PAGE : 24
David Chang		VERSION : 12

CUSTOMER ACCEPTANCE SPECIFICATIONS

MODEL NO. :

ET0700G0DM6

(RoHS)

FOR MESSRS :

CUSTOMER'S APPROVAL

DATE :

BY :

RECORDS OF REVISION

DOC . FIRST ISSUE

FEB.17, 2009

DATE	REVISED PAGE NO.	SUMMARY																																				
FEB.18, 2009	3	<p>4. ELECTRICAL CHARACTERISTICS</p> <table border="1"> <thead> <tr> <th>PARAMETER</th> <th>SYMBOL</th> <th>CONDITION</th> <th>MIN.</th> <th>TYP.</th> <th>MAX.</th> <th>UNIT</th> <th>REMARK</th> </tr> </thead> <tbody> <tr> <td>POWER SUPPLY CURRENT FOR LED DRIVER</td> <td>ICC</td> <td>VCC-VSS=3.3V LED B/L=ON</td> <td>—</td> <td>(160)</td> <td>(200)</td> <td>mA</td> <td></td> </tr> </tbody> </table> <p style="text-align: center;">↓</p> <table border="1"> <thead> <tr> <th>PARAMETER</th> <th>SYMBOL</th> <th>CONDITION</th> <th>MIN.</th> <th>TYP.</th> <th>MAX.</th> <th>UNIT</th> <th>REMARK</th> </tr> </thead> <tbody> <tr> <td>POWER SUPPLY CURRENT FOR LED DRIVER</td> <td>ICC</td> <td>VCC-VSS=3.3V LED B/L=ON</td> <td>—</td> <td>(600)</td> <td>(780)</td> <td>mA</td> <td></td> </tr> </tbody> </table>	PARAMETER	SYMBOL	CONDITION	MIN.	TYP.	MAX.	UNIT	REMARK	POWER SUPPLY CURRENT FOR LED DRIVER	ICC	VCC-VSS=3.3V LED B/L=ON	—	(160)	(200)	mA		PARAMETER	SYMBOL	CONDITION	MIN.	TYP.	MAX.	UNIT	REMARK	POWER SUPPLY CURRENT FOR LED DRIVER	ICC	VCC-VSS=3.3V LED B/L=ON	—	(600)	(780)	mA					
PARAMETER	SYMBOL	CONDITION	MIN.	TYP.	MAX.	UNIT	REMARK																															
POWER SUPPLY CURRENT FOR LED DRIVER	ICC	VCC-VSS=3.3V LED B/L=ON	—	(160)	(200)	mA																																
PARAMETER	SYMBOL	CONDITION	MIN.	TYP.	MAX.	UNIT	REMARK																															
POWER SUPPLY CURRENT FOR LED DRIVER	ICC	VCC-VSS=3.3V LED B/L=ON	—	(600)	(780)	mA																																
	4	<p>5.1 AC ELECTRICAL CHARACTERISTICS</p>																																				
MAR.09, 2009	5	<p>5.2 SYNC MODE SIGNAL CHARACTERISTICS</p> <table border="1"> <thead> <tr> <th>PARAMETER</th> <th>SYMBOL</th> <th>MIN.</th> <th>TYP.</th> <th>MAX.</th> <th>UNIT</th> </tr> </thead> <tbody> <tr> <td>HSYNC FIRST HORIZONTAL DATA TIME</td> <td>T₁₀</td> <td>—</td> <td>ST10H7-01-01</td> <td>T₁₀</td> <td></td> </tr> <tr> <td>HSYNC DE TIME</td> <td>T₁₁</td> <td>—</td> <td>ST10H7-01-01</td> <td>T₁₁</td> <td></td> </tr> </tbody> </table> <p style="text-align: center;">↓</p> <table border="1"> <thead> <tr> <th>PARAMETER</th> <th>SYMBOL</th> <th>MIN.</th> <th>TYP.</th> <th>MAX.</th> <th>UNIT</th> </tr> </thead> <tbody> <tr> <td>HSYNC FIRST HORIZONTAL DATA TIME</td> <td>T₁₀</td> <td>—</td> <td>ST10H7-01-01</td> <td>T₁₀</td> <td></td> </tr> <tr> <td>HSYNC DE TIME</td> <td>T₁₁</td> <td>—</td> <td>ST10H7-01-01</td> <td>T₁₁</td> <td></td> </tr> </tbody> </table>	PARAMETER	SYMBOL	MIN.	TYP.	MAX.	UNIT	HSYNC FIRST HORIZONTAL DATA TIME	T ₁₀	—	ST10H7-01-01	T ₁₀		HSYNC DE TIME	T ₁₁	—	ST10H7-01-01	T ₁₁		PARAMETER	SYMBOL	MIN.	TYP.	MAX.	UNIT	HSYNC FIRST HORIZONTAL DATA TIME	T ₁₀	—	ST10H7-01-01	T ₁₀		HSYNC DE TIME	T ₁₁	—	ST10H7-01-01	T ₁₁	
PARAMETER	SYMBOL	MIN.	TYP.	MAX.	UNIT																																	
HSYNC FIRST HORIZONTAL DATA TIME	T ₁₀	—	ST10H7-01-01	T ₁₀																																		
HSYNC DE TIME	T ₁₁	—	ST10H7-01-01	T ₁₁																																		
PARAMETER	SYMBOL	MIN.	TYP.	MAX.	UNIT																																	
HSYNC FIRST HORIZONTAL DATA TIME	T ₁₀	—	ST10H7-01-01	T ₁₀																																		
HSYNC DE TIME	T ₁₁	—	ST10H7-01-01	T ₁₁																																		
	9	<p>7. OUTLINE DIMENSIONS MARK Δ : ADD PULL TAPE & CHANGE CONNECTOR & MODIFY DIMENSION</p>																																				
	10	<p>8. BLOCK DIAGRAM ADD FRAME GROUND & NOTE</p>																																				
	14	<p>11.2 THE BRIGHTNESS CONTROLLED BY BACKLIGHT CURRENT OF LEDCTRL.</p>																																				
JUN.04, 2009	1	<p>2. MECHANICAL SPECIFICATIONS (3)MODULE SIZE : 165W * 104.44H *9.2D(MAX.) mm (WITHOUT FPC) → 166W * 105.44H *9.85D(MAX.) mm (WITHOUT FPC & LED BL'S CABLE)</p>																																				
	9	<p>7. OUTLINE DIMENSIONS MARK Δ : MODIFY PCB & CHANGE C/N TYPE, ADD BOTTOM FRAME</p>																																				
SEP.30, 2009	3	<p>4. ELECTRICAL CHARACTERISTICS VDD-VSS : 3.0(MIN.) → 3.2(MIN.)</p>																																				
DEC.01, 2009	2	<p>3.1 ELECTRICAL ABSOLUTE MAXIMUM RATINGS.</p> <table border="1"> <thead> <tr> <th>PARAMETER</th> <th>SYMBOL</th> <th>MIN.</th> <th>MAX.</th> <th>UNIT</th> <th>REMARK</th> </tr> </thead> <tbody> <tr> <td>LED BACKLIGHT POWER DISSIPATION</td> <td>PD</td> <td>—</td> <td>2590</td> <td>mW</td> <td></td> </tr> <tr> <td>LED BACKLIGHT FORWARD CURRENT</td> <td>IF</td> <td>—</td> <td>800</td> <td>mA</td> <td></td> </tr> </tbody> </table> <p style="text-align: center;">↓</p> <table border="1"> <thead> <tr> <th>PARAMETER</th> <th>SYMBOL</th> <th>MIN.</th> <th>MAX.</th> <th>UNIT</th> <th>REMARK</th> </tr> </thead> <tbody> <tr> <td>LED BACKLIGHT POWER DISSIPATION</td> <td>PD</td> <td>—</td> <td>2592</td> <td>mW</td> <td></td> </tr> <tr> <td>LED BACKLIGHT FORWARD CURRENT</td> <td>IF</td> <td>—</td> <td>240</td> <td>mA</td> <td></td> </tr> </tbody> </table>	PARAMETER	SYMBOL	MIN.	MAX.	UNIT	REMARK	LED BACKLIGHT POWER DISSIPATION	PD	—	2590	mW		LED BACKLIGHT FORWARD CURRENT	IF	—	800	mA		PARAMETER	SYMBOL	MIN.	MAX.	UNIT	REMARK	LED BACKLIGHT POWER DISSIPATION	PD	—	2592	mW		LED BACKLIGHT FORWARD CURRENT	IF	—	240	mA	
PARAMETER	SYMBOL	MIN.	MAX.	UNIT	REMARK																																	
LED BACKLIGHT POWER DISSIPATION	PD	—	2590	mW																																		
LED BACKLIGHT FORWARD CURRENT	IF	—	800	mA																																		
PARAMETER	SYMBOL	MIN.	MAX.	UNIT	REMARK																																	
LED BACKLIGHT POWER DISSIPATION	PD	—	2592	mW																																		
LED BACKLIGHT FORWARD CURRENT	IF	—	240	mA																																		

RECORDS OF REVISION

DOC . FIRST ISSUE

FEB.17, 2009

DATE

REVISED PAGE NO.

SUMMARY

DEC.01, 2009

3

4. ELECTRICAL CHARACTERISTICS

PARAMETER	SYMBOL	CONDITION	MIN.	TYP.	MAX.	UNIT	REMARK
POWER SUPPLY CURRENT	IDD	VDD-VSS = 3.3V	—	(220)	(270)	mA	NOTE (2)
POWER SUPPLY CURRENT FOR LED DRIVER	ICC	VCC-VSS=3.3V LED B/L=ON	—	(600)	(780)	mA	
LED LIFE TIME	—	—	(30K)	(40K)	—	HRS	

PARAMETER	SYMBOL	CONDITION	MIN.	TYP.	MAX.	UNIT	REMARK
POWER SUPPLY CURRENT	IDD	VDD-VSS = 3.3V	—	220	270	mA	NOTE (2)
POWER SUPPLY CURRENT FOR LED DRIVER	ICC	VCC-VSS=3.3V LED B/L=ON	—	600	780	mA	
LED LIFE TIME	—	—	30K	40K	—	HRS	

7

6.1 OPTICAL CHARACTERISTICS

ITEM	SYMBOL	CONDITION	MIN.	TYP.	MAX.	UNIT	REMARK
VIEWING ANGLE	θ_v	$\theta_v=0^\circ$	(60)	(65)	—	—	NOTE (2)
	θ_h	CR ≥ 10	(60)	(65)	—	d e g.	NOTE (2)
	θ_v	$\theta_v=0^\circ$	(65)	(70)	—	—	NOTE (3)
CONTRAST RATIO	CR	$\theta_v=0^\circ$, $\theta_h=0^\circ$	(300)	—	—	—	NOTE (3)
COLOR OF CIE COORDINATE	WHITE	$\theta_v=0^\circ$, $\theta_h=0^\circ$	(0.36)	(0.31)	(0.36)	—	NOTE (5)
	RED	$\theta_v=0^\circ$, $\theta_h=0^\circ$	(0.29)	(0.34)	(0.29)	—	
	GREEN	$\theta_v=0^\circ$, $\theta_h=0^\circ$	(0.56)	(0.61)	(0.66)	—	
	BLUE	$\theta_v=0^\circ$, $\theta_h=0^\circ$	(0.49)	(0.54)	(0.59)	—	
	WHITE	$\theta_v=0^\circ$, $\theta_h=0^\circ$	(0.09)	(0.14)	(0.19)	—	
	BLUE	$\theta_v=0^\circ$, $\theta_h=0^\circ$	(0.11)	(0.16)	(0.21)	—	
THE BRIGHTNESS OF MODULE	B	$\theta_v=0^\circ$, $\theta_h=0^\circ$ IF = 160mA	(300)	—	—	cd/m ²	NOTE (6)

JAN.18, 2010

7

6.1 OPTICAL CHARACTERISTICS

THE BRIGHTNESS OF MODULE: (TYP.) — → (TYP.) 330

MAR.10, 2010

7

6.1 OPTICAL CHARACTERISTICS

THE BRIGHTNESS OF MODULE: (MIN.) 300 → (MIN.) 350
(TYP.) 330 → (TYP.) 400

JUL.12, 2010

9

7. OUTLINE DIMENSIONS

MARK Δ : ADD INSULATED TAPE

APR.21, 2011

2

3.1 ELECTRICAL ABSOLUTE MAXIMUM RATINGS

VDD-VSS: (MAX.) +7 → (MAX.) 6.5

8

NOTE (2) : θ_v - → θ_v +

NOTE (4) : TR AND TF → TR AND TF

MAR.01, 2012

4

5.1 AC ELECTRICAL CHARACTERISTICS

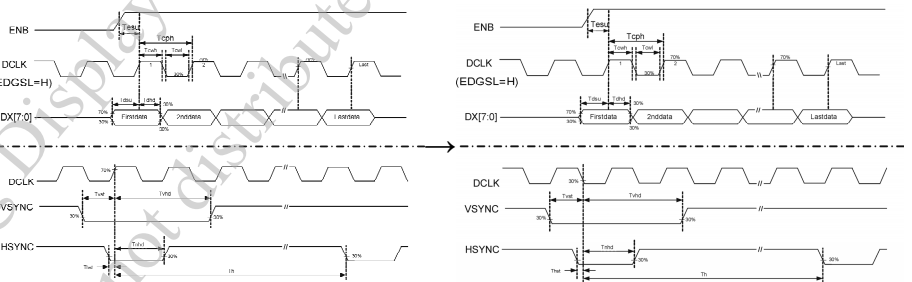

5

5.2 SYNC MODE SIGNAL CHARACTERISTICS

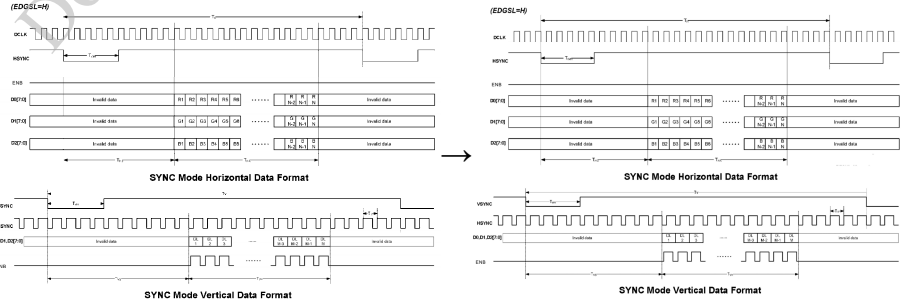

RECORDS OF REVISION

FEB.17, 2009

DATE	REVISED PAGE NO.	SUMMARY
MAR.01, 2012	6	<p>5.3 DE MODE SIGNAL CHARACTERISTICS</p>
MAR.09, 2012	6	<p>5.3 DE MODE SIGNAL CHARACTERISTICS</p>

CONFIDENTIAL
 Authorized for Emerging Display Technologies Corporation Only.
 Do not distribute without authorization.

TABLE OF CONTENTS

NO.	ITEM	PAGE
1.	GENERAL SPECIFICATIONS -----	1
2.	MECHANICAL SPECIFICATIONS -----	1
3.	ABSOLUTE MAXIMUM RATINGS -----	2
4.	ELECTRICAL CHARACTERISTICS -----	3
5.	TIMING CHARACTERISTICS -----	4 ~ 6
6.	OPTICAL CHARACTERISTICS -----	7, 8
7.	OUTLINE DIMENSIONS -----	9
8.	BLOCK DIAGRAM -----	10
9.	DETAIL DRAWING OF DOT MATRIX -----	11
10.	INTERFACE SIGNALS -----	12, 13
11.	POWER SUPPLY -----	14
12.	INSPECTION CRITERION -----	15 ~ 24

CONFIDENTIAL
Authorized for
Emerging Display Technologies Corporation Only.
Do not distribute without authorization.

1. GENERAL SPECIFICATIONS

1.1 APPLICATION NOTES FOR CONTROLLER/DRIVER

PLEASE REFER TO :

HIMAX HX8262 - A

HIMAX HX8678 - A

1.2 MATERIAL SAFETY DESCRIPTION

ASSEMBLIES SHALL COMPLY WITH EUROPEAN ROHS REQUIREMENTS, INCLUDING PROHIBITED MATERIALS/COMPONENTS CONTAINING LEAD, MERCURY, CADMIUM, HEXAVALENT CHROMIUM, POLYBROMINATED BIPHENYLS (PBB) AND POLYBROMINATED DIPHENYL ETHERS (PBDE)

2. MECHANICAL SPECIFICATIONS

(1) DISPLAY SIZE	-----	7 inch
(2) NUMBER OF DOTS	-----	800W * (RGB) * 480H DOTS
(3) MODULE SIZE	-----	166W * 105.44H *9.85D(MAX.) mm (WITHOUT FPC & LED BL'S CABLE)
(4) ACTIVE AREA	-----	152.4W * 91.44H mm
(5) DOT SIZE	-----	0.0635W * 0.1905H mm
(6) PIXEL SIZE	-----	0.1905W * 0.1905H mm
(7) LCD TYPE	-----	TFT, TRANSMISSIVE, ANTE-GLARE
(8) COLOR	-----	262K
(9) VIEWING DIRECTION	-----	6 O'CLOCK
(10) BACK LIGHT	-----	LED, COLOR : WHITE
(11) INTERFACE MODE	-----	RGB 18BIT PARALLEL (DE/SYNC MODE)

3. ABSOLUTE MAXIMUM RATINGS

3.1 ELECTRICAL ABSOLUTE MAXIMUM RATINGS .

PARAMETER	SYMBOL	MIN.	MAX.	UNIT	REMARK
POWER SUPPLY VOLTAGE	VDD-VSS	-0.5	6.5	V	
INPUT VOLTAGE	VIN-VSS	-0.3	VDD+0.3	V	
STATIC ELECTRICITY	—	—	—	V	NOTE(1)
LED BACKLIGHT POWER DISSIPATION	PD	—	2592	mW	
LED BACKLIGHT FORWARD CURRENT	IF	—	240	mA	

3.2 ENVIRONMENTAL ABSOLUTE MAXIMUM RATINGS .

I T E M	OPERATING		STORAGE		REMARK
	MIN.	MAX.	MIN.	MAX.	
AMBIENT TEMPERATURE	-20°C	70°C	-30°C	80°C	NOTE (1), (2)
HUMIDITY	NOTE (3)		NOTE (3)		WITHOUT CONDENSATION
VIBRATION	—	2.45 m/s ² (0.25 G)	—	11.76 m/s ² (1.2 G)	5~20Hz, 1HR 20~500Hz(20Hz), 1HR 20~500Hz(500Hz), 1HR X,Y,Z,TOTAL 3HRS
SHOCK	—	29.4 m/s ² (3 G)	—	490 m/s ² (50 G)	10 m SECONDS XYZ DIRECTIONS 1 TIME EACH
CORROSIVE GAS	NOT ACCEPTABLE		NOT ACCEPTABLE		

NOTE (1) : Ta AT -30°C : 48HRS MAX.
80°C : 168HRS MAX.

NOTE (2) : BACKGROUND COLOR CHANGES SLIGHTLY DEPENDING ON AMBIENT TEMPERATURE
THIS PHENOMENON IS REVERSIBLE.

NOTE (3) : Ta ≤ 60°C : 90%RH MAX (96HRS MAX).

Ta > 60°C : ABSOLUTE HUMIDITY MUST BE LOWER THAN THE HUMIDITY
OF 90%RH AT 60°C(96HRS MAX).

4. ELECTRICAL CHARACTERISTICS

Ta = 25 °C

PARAMETER	SYMBOL	CONDITION	MIN.	TYP.	MAX.	UNIT	REMARK
POWER SUPPLY VOLTAGE	VDD-VSS	—	3.2	3.3	3.6	V	
POWER SUPPLY VOLTAGE FOR LED DRIVER	VCC-VSS	—	2.5	3.3	3.6	V	
LOW LEVEL INPUT VOLTAGE	VIL	—	0	—	0.3*VDD	V	NOTE (1)
HIGH LEVEL INPUT VOLTAGE	VIH	—	0.7*VDD	—	VDD	V	NOTE (1)
POWER SUPPLY CURRENT	IDD	VDD-VSS = 3.3V	—	220	270	mA	NOTE (2)
POWER SUPPLY CURRENT FOR LED DRIVER	ICC	VCC-VSS=3.3V LED B/L=ON	—	600	780	mA	
POWER SUPPLY FOR LED BACKLIGHT	V _{BL+} - V _{BL-}	IF=160mA	9	9.9	10.8	V	NOTE (3)
LED LIFE TIME	—	—	30K	40K	—	HRS	

NOTE (1) : APPLIED TO TERMINALS B5~B0 , G5~G0 , R5~R0 , DCLK , HSYNC , VSYNC , ENB.

NOTE (2) : THE DISPLAY PATTERN IS ALL "WHITE".

NOTE (3) : INTERNAL CIRCUIT DIAGRAM OF BACKLIGHT

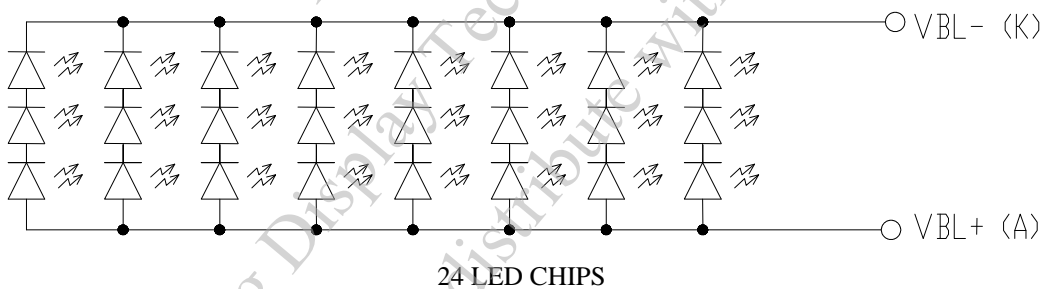

5. TIMING CHARACTERISTICS

5.1 AC ELECTRICAL CHARACTERISTICS

PARAMETER	SYMBOL	MIN.	TYP.	MAX.	UNIT
HSYNC SETUP TIME	T_{hst}	6	—	—	ns
HSYNC HOLD TIME	T_{hhd}	6	—	—	ns
VSYNC SETUP TIME	T_{vst}	6	—	—	ns
VSYNC HOLD TIME	T_{vhd}	6	—	—	ns
DATA SETUP TIME	T_{dsu}	6	—	—	ns
DATA HOLD TIME	T_{dhd}	6	—	—	ns
ENB SETUP TIME	T_{esu}	6	—	—	ns
SOURCE OUTPUT SETTLING TIME	T_{ST}	—	—	15	μ s
SOURCE OUTPUT LOADING R	R_{SL}	—	2	—	K ohm
SOURCE OUTPUT LOADING C	C_{SL}	—	60	—	pF

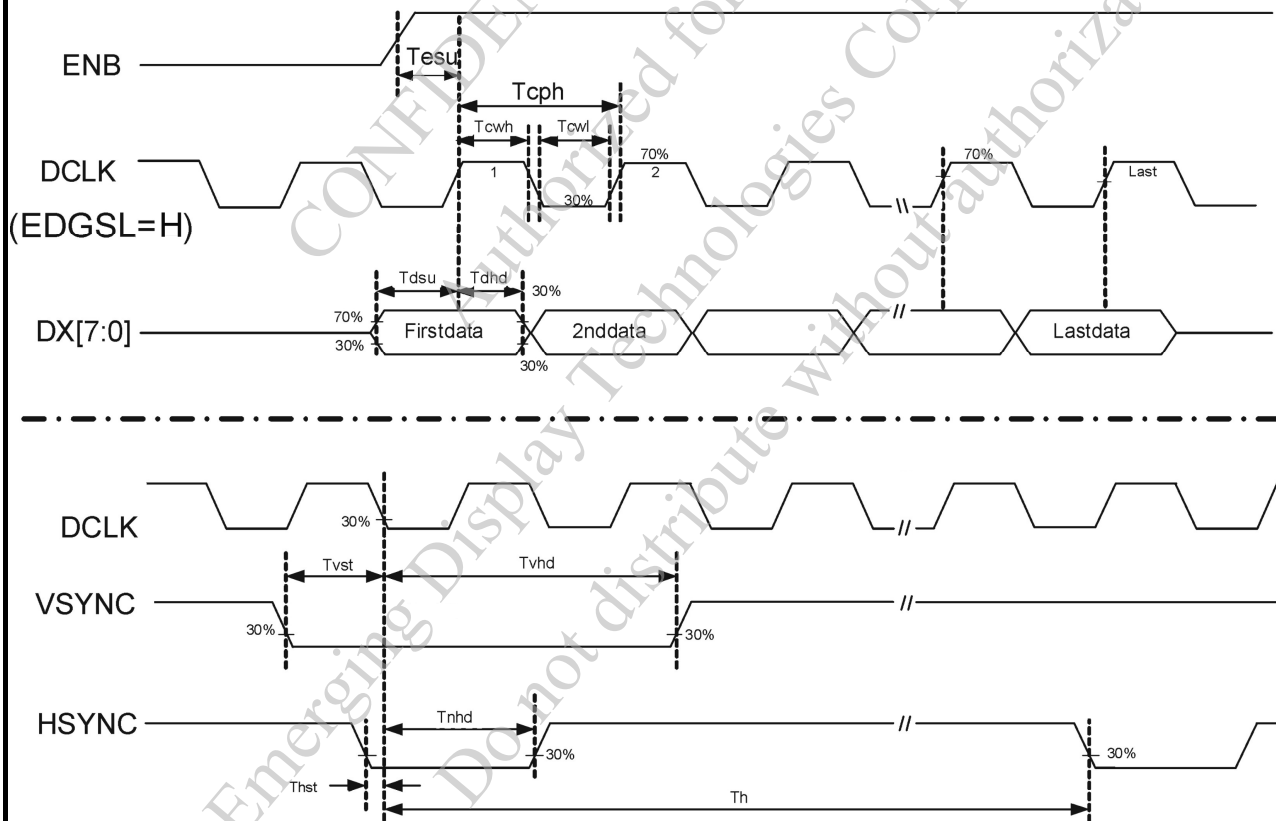

5.2 SYNC MODE SIGNAL CHARACTERISTICS

PARAMETER	SYMBOL	SPEC			UNIT
		MIN.	TYP.	MAX.	
DCLK FREQUENCY	F_{CPH}	—	33.26	—	MHz
DCLK PERIOD	T_{CPH}	—	30.06	—	ns
DCLK PULSE DUTY	T_{CWH}	40	50	60	%
HSYNC PERIOD	T_H	930	1056	1057	T_{CPH}
HSYNC PULSE WIDTH	T_{WH}	1	128	—	T_{CPH}
HSYNC -FIRST HORIZONTAL DATA TIME	T_{HS}	—	216	—	T_{CPH}
HSYNC ACTIVE TIME	T_{HA}	—	800	—	T_{CPH}
VSYNC PERIOD	T_V	—	525	—	T_H
VSYNC PULSE WIDTH	T_{WV}	1	2	—	T_H
VSYNC -DE TIME	T_{VS}	—	35	—	T_H
VSYNC ACTIVE TIME	T_{VA}	—	480	—	T_H

(EDGSL=H)

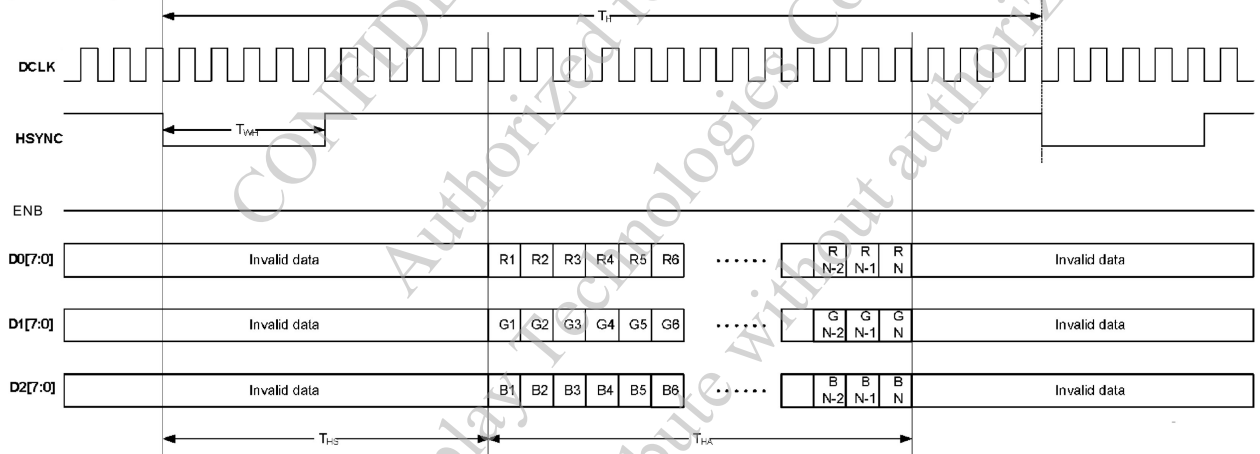

SYNC Mode Horizontal Data Format

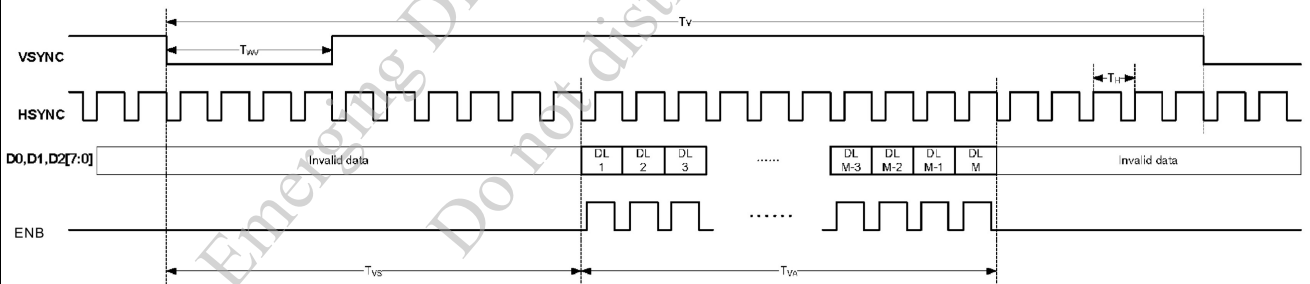

SYNC Mode Vertical Data Format

5.3 DE MODE SIGNAL CHARACTERISTICS

PARAMETER	SYMBOL	MIN.	TYP.	MAX.	UNIT
DCLK FREQUENCY	F_{CPH}	—	33.26	—	MHZ
DCLK PERIOD	T_{CPH}	—	30.06	—	ns
DCLK PULSE DUTY	T_{CWH}	40	50	60	%
ENB PERIOD	$T_{DEH} + T_{DEL}$	1000	1056	1200	T_{CPH}
ENB PULSE WIDTH	T_{DEH}	—	800	—	T_{CPH}
ENB FRAME BLANKING	T_{DEB}	10	45	110	$T_{DEH} + T_{DEL}$
ENB FRAME WIDTH	T_{DE}	—	480	—	$T_{DEH} + T_{DEL}$
OEV PULSE WIDTH	T_{OEV}	—	150	—	T_{CPH}
CKV PULSE WIDTH	T_{CKV}	—	133	—	T_{CPH}
ENB(INTERNAL)-STV TIME	T_1	—	4	—	T_{CPH}
ENB(INTERNAL)-CKV TIME	T_2	—	40	—	T_{CPH}
ENB(INTERNAL)-OEV TIME	T_3	—	23	—	T_{CPH}
ENB(INTERNAL)-POL TIME	T_4	—	157	—	T_{CPH}
STV PULSE WIDTH	—	—	1	—	T_H

NOTE : (1) $T_{HS} + T_{HA} < T_H$

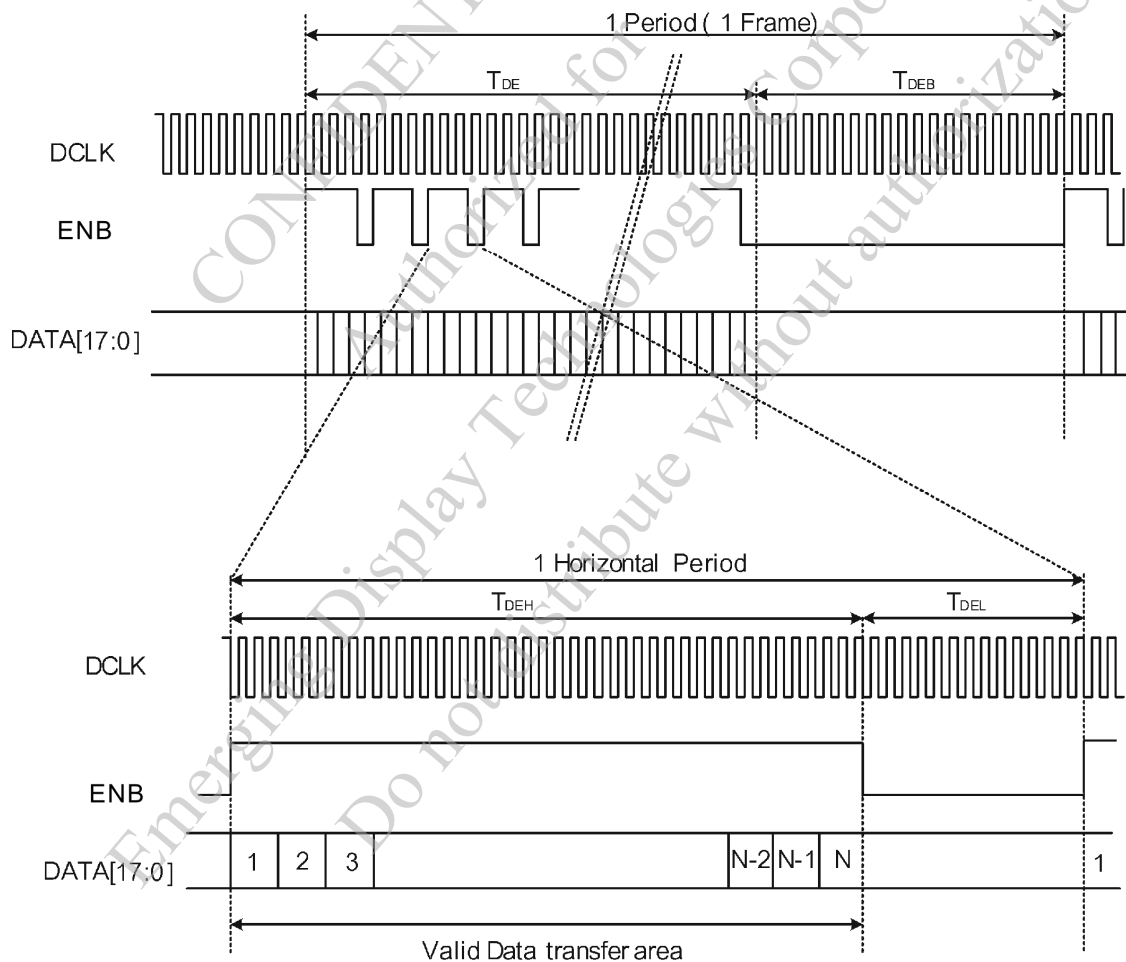

6. OPTICAL CHARACTERISTICS (NOTE1)
6.1 OPTICAL CHARACTERISTICS

Ta = 25 ± 2 °C

I T E M		SYMBOL	CONDITION	MIN.	TYP.	MAX.	UNIT	REMARK	
VIEWING ANGLE		θ_{y+}	CR ≥ 10	60	65	—	deg.	NOTE (2) NOTE (3)	
		θ_{y-}		$\theta_x=0^\circ$	60	65			—
		θ_{x+}		$\theta_y=0^\circ$	65	70			—
		θ_{x-}			65	70			—
CONTRAST RATIO		CR	$\theta_x=0^\circ, \theta_y=0^\circ$	300	350	—	—	NOTE (3)	
RESPONSE TIME		T _R (rise)	$\theta_x=0^\circ, \theta_y=0^\circ$	—	5	10	—	NOTE (4)	
		T _F (fall)		—	15	20			
COLOR OF CIE COORDINATE	WHITE	W _x	$\theta_x=0^\circ, \theta_y=0^\circ$ IF = 160 mA (NTSC : 45 %)	0.26	0.31	0.36	—	NOTE (5)	
		W _y		0.29	0.34	0.39			
	RED	R _x		0.51	0.56	0.61			
		R _y		0.29	0.34	0.39			
	GREEN	G _x		0.28	0.33	0.38			
		G _y		0.53	0.58	0.63			
	BLUE	B _x		0.10	0.15	0.20			
		B _y		0.07	0.12	0.17			
THE BRIGHTNESS OF MODULE		B	$\theta_x=0^\circ, \theta_y=0^\circ$ IF = 160mA	350	400	—	cd/m ²	NOTE (6)	
THE UNIFORMITY OF MODULE		—		75	80	—	%		

NOTE (1) : TEST EQUIPMENT SETUP :

AFTER STABILIZING AND LEAVING THE PANEL ALONE AT A GIVEN TEMPERATURE FOR 30 MINUTES, THE MEASUREMENT SHOULD BE EXECUTED. MEASUREMENT SHOULD BE EXECUTED IN A STABLE, WINDLESS , AND DARK ROOM. OPTICAL SPECIFICATIONS ARE MEASURED BY TOPCON BM-7 (FAST) WITH A VIEWING ANGLE OF 1° AT A DISTANCE OF 50cm AND NORMAL DIRECTION.

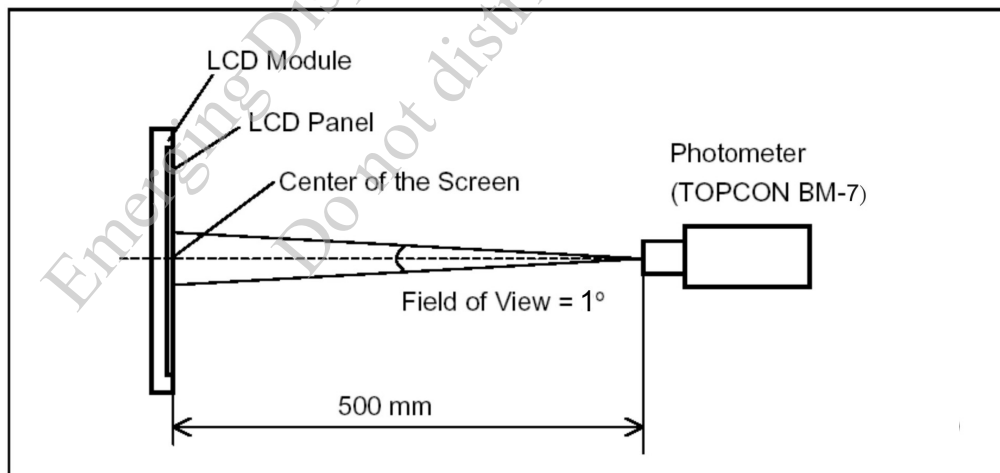

NOTE (2) : DEFINITION OF VIEWING ANGLE :

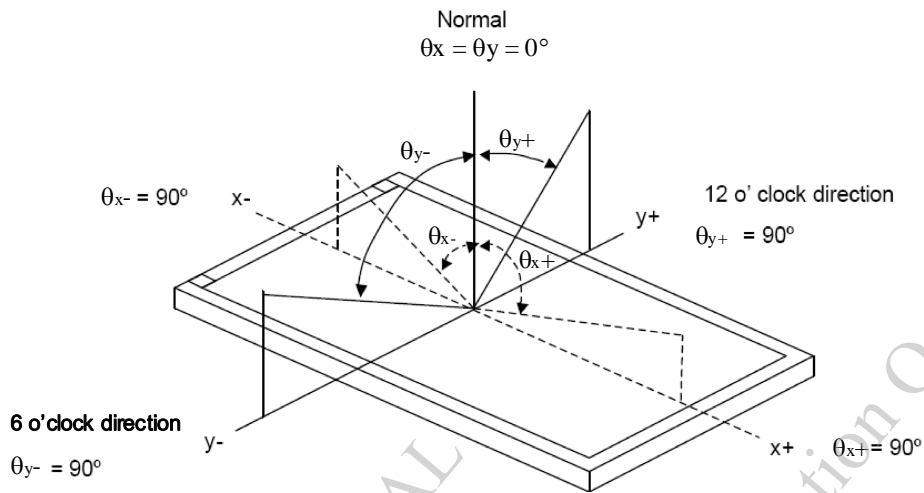

NOTE (3) : DEFINITION OF CONTRAST RATIO :

$$\text{CONTRAST RATIO (CR)} = \frac{\text{BRIGHTNESS MEASURED WHEN LCD IS AT "WHITE STATE"}}{\text{BRIGHTNESS MEASURED WHEN LCD IS AT "BLACK STATE"}}$$

NOTE (4) : DEFINITION OF RESPONSE TIME : T_R AND T_F

THE FIGURE BELOW IS THE OUTPUT SIGNAL OF THE PHOTO DETECTOR.

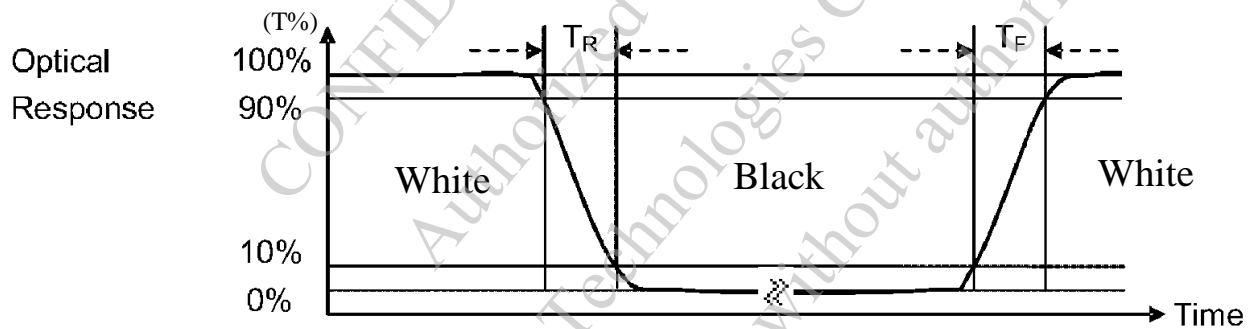

NOTE (5) : THE 100% TRANSMISSION IS DEFINED AS THE TRANSMISSION OF LCD PANEL WHEN ALL THE INPUT TERMINALS OF MODULE ARE ELECTRICALLY OPENED.

NOTE (6) : BRIGHTNESS MEASURED WHEN LCD IS AT "WHITE STATE"

6.2 THE TEST METHOD OF BRIGHTNESS AND UNIFORMITY

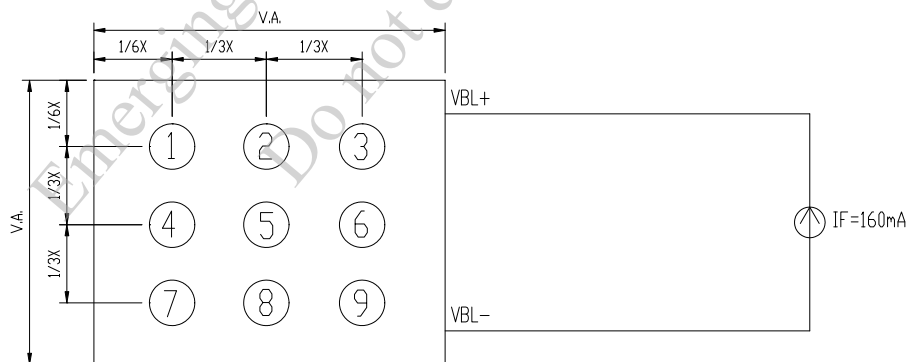

UNIT : mm

6.3 THE CALCULATING METHOD OF UNIFORMITY

$$\text{UNIFORMITY} = \left[1 - \frac{\text{MAXIMUM BRIGHTNESS} - \text{MINIMUM BRIGHTNESS}}{\text{AVERAGE BRIGHTNESS}} \right] \times 100\%$$

7. OUTLINE DIMENSIONS

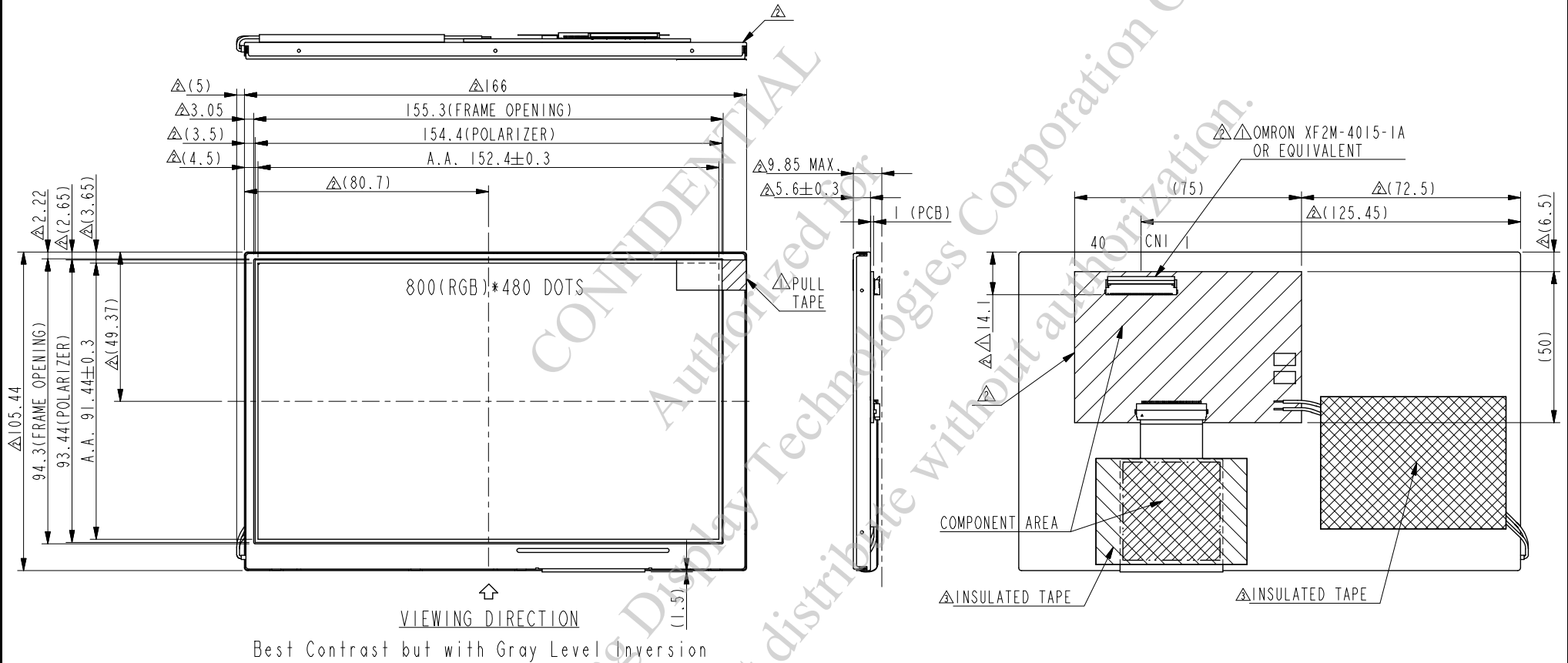

8. BLOCK DIAGRAM

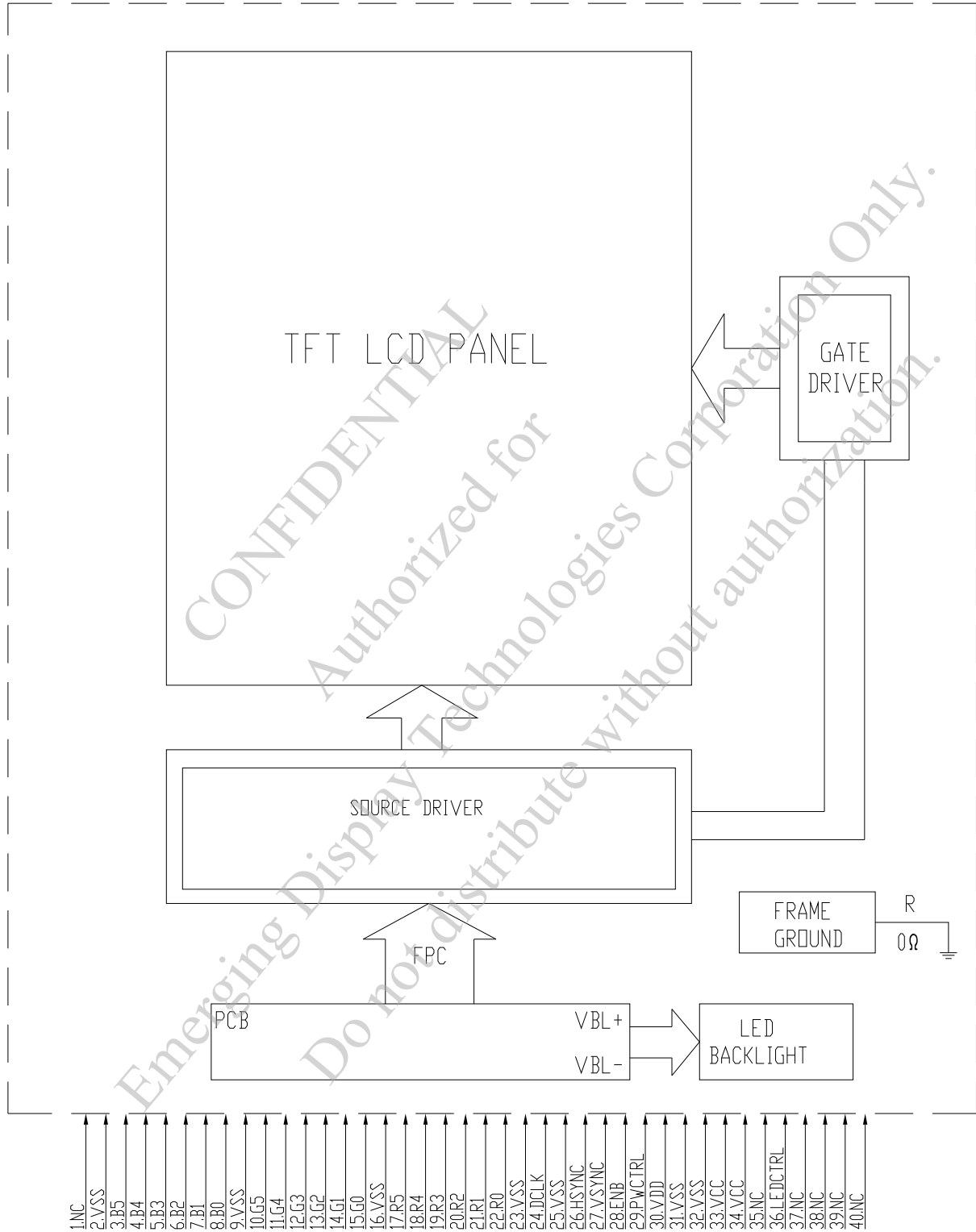

NOTE : UD = "H" LEVEL : OUT1→480 ; LR = "H" LEVEL : OUT1→800(DEFAULT)
"L LEVEL : OUT480→1 (DEFAULT) "L LEVEL : OUT800→1

9. DETAIL DRAWING OF DOT MATRIX

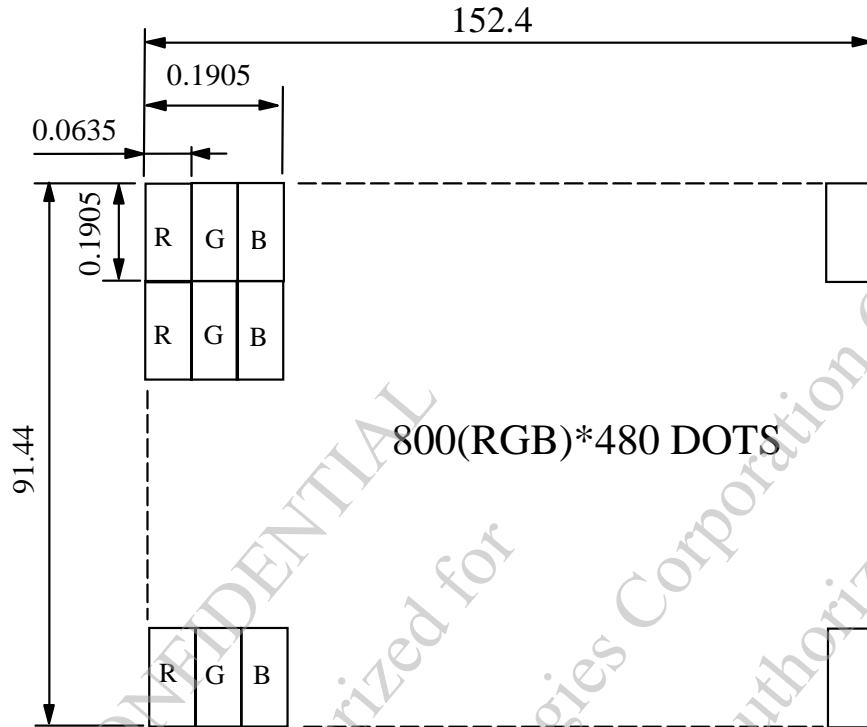

UNIT : mm
SCALE : NTS
NOT SPECIFIED TOLERANCE IS ± 0.1
DOTS MATRIX TOLERANCE IS ± 0.01

CONFIDENTIAL
Authorized for Emerging Display Technologies Corporation Only.
Do not distribute without authorization.

10. INTERFACE SIGNALS

PIN NO	SYMBOL	I/O	FUNCTION
1	NC	—	NON CONNECTION
2	VSS	P	GROUND (VSS IS CONNECTED TO METAL HOUSING WITH CONDUCTIVE TAPE)
3	B5	I	BLUE DATA BIT 5
4	B4	I	BLUE DATA BIT 4
5	B3	I	BLUE DATA BIT 3
6	B2	I	BLUE DATA BIT 2
7	B1	I	BLUE DATA BIT 1
8	B0	I	BLUE DATA BIT 0
9	VSS	P	GROUND (VSS IS CONNECTED TO METAL HOUSING WITH CONDUCTIVE TAPE)
10	G5	I	GREEN DATA BIT 5
11	G4	I	GREEN DATA BIT 4
12	G3	I	GREEN DATA BIT 3
13	G2	I	GREEN DATA BIT 2
14	G1	I	GREEN DATA BIT 1
15	G0	I	GREEN DATA BIT 0
16	VSS	P	GROUND (VSS IS CONNECTED TO METAL HOUSING WITH CONDUCTIVE TAPE)
17	R5	I	RED DATA BIT 5
18	R4	I	RED DATA BIT 4
19	R3	I	RED DATA BIT 3
20	R2	I	RED DATA BIT 2
21	R1	I	RED DATA BIT 1
22	R0	I	RED DATA BIT 0
23	VSS	P	GROUND (VSS IS CONNECTED TO METAL HOUSING WITH CONDUCTIVE TAPE)
24	DCLK	I	DOT DATA CLOCK
25	VSS	P	GROUND (VSS IS CONNECTED TO METAL HOUSING WITH CONDUCTIVE TAPE)
26	HSYNC	I	HORIZONTAL SYNC INPUT. INTERNALLY PULL HIGH.
27	VSYNC	I	VERTICAL SYNC INPUT. INTERNALLY PULL HIGH.
28	ENB	I	INPUT DATA ENABLE CONTROL. INTERNALLY PULLED LOW.

PIN NO	SYMBOL	I/O	FUNCTION	
			LOGIC LEVEL H=3.3V L=0V	REMARK
29	PWCTRL	I	PWCTRL	POWER ON SHUTDOWN
			WHEN INTERNAL LED DRIVER : JP7 1-2(DEFAULT) WHEN EXTERNAL LED DRIVER : JP7 2-3	
30	VDD	P	POWER SUPPLY VOLTAGE	
31	VSS	P	GROUND (VSS IS CONNECTED TO METAL HOUSING WITH CONDUCTIVE TAPE)	
32	VSS	P	GROUND (VSS IS CONNECTED TO METAL HOUSING WITH CONDUCTIVE TAPE)	
33	VCC	P	POWER SUPPLY FOR LED DRIVER CIRCUIT	
34	VCC	P	POWER SUPPLY FOR LED DRIVER CIRCUIT	
35	NC	—	NON CONNECTION (USING INTERNAL LED DRIVER) OR ANODE (USING EXTERNAL LED DRIVER) WHEN INTERNAL LED DRIVER : JP4 1-2 (DEFAULT) WHEN EXTERNAL LED DRIVER : JP4 2-3	
36	LEDCTRL	I	BRIGHTNESS CONTROL FOR LED BACKLIGHT ; LEDCTRL (USING INTERNAL LED DRIVER) OR CATHODE (USING EXTERNAL LED DRIVER) WHEN INTERNAL LED DRIVER : JP5 1-2 (DEFAULT) JP6 1-2 CONNECT(DEFAULT) WHEN EXTERNAL LED DRIVER : JP5 2-3 JP6 NON CONNECTION	
37	NC	—	NON CONNECTION	
38	NC	—	NON CONNECTION	
39	NC	—	NON CONNECTION	
40	NC	—	NON CONNECTION	

1.1. POWER SUPPLY
1.1.1 POWER SUPPLY FOR LCM

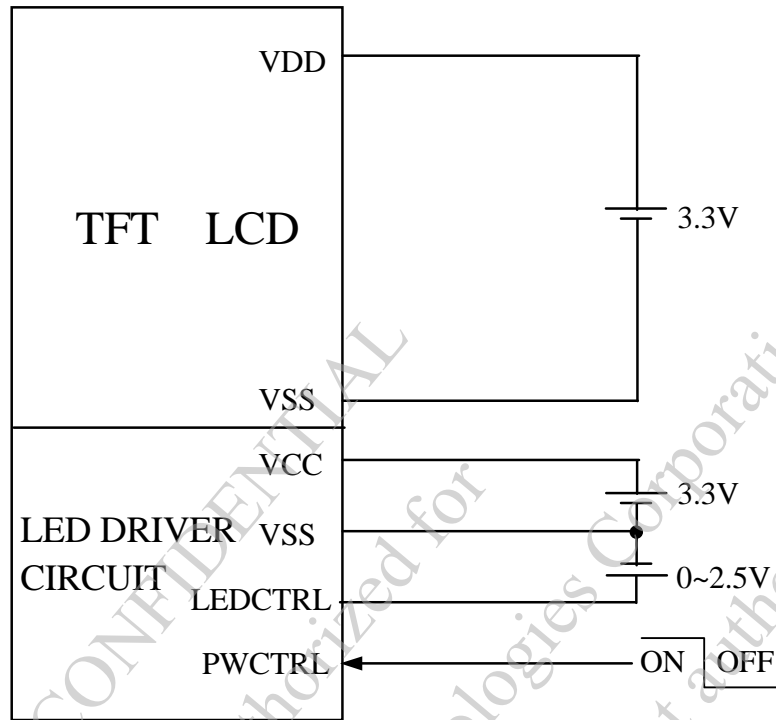

11.2 THE BRIGHTNESS CONTROLLED BY BACKLIGHT CURRENT OF LEDCTRL.

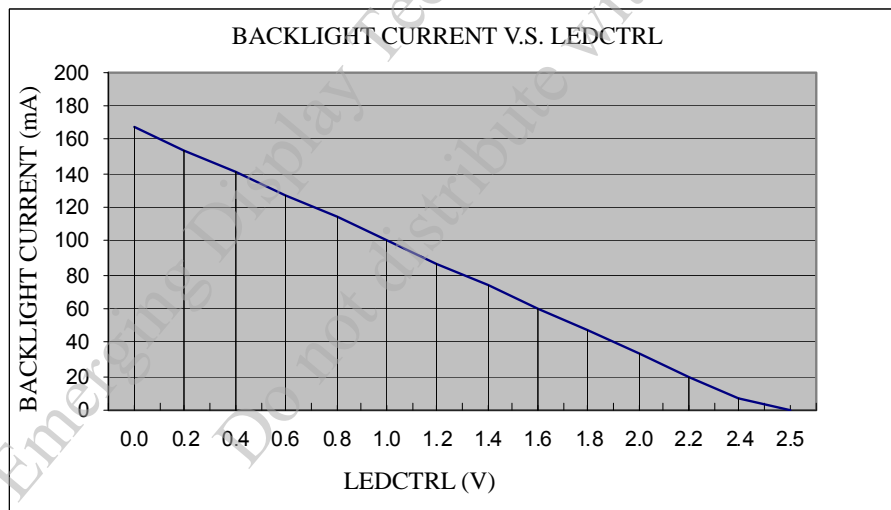

12. INSPECTION CRITERION

12.1 APPLICATION

This inspection standard is to be applied to the LCD module delivered from EMERGING DISPLAY TECHNOLOGIES CORP.(E.D.T) to customers

12.2 INSPECTION CONDITIONS

12.2.1 (1) Observation Distance : 35cm±5cm

(2) View Angle :

Non-operation Condition : ±5°(perpendicular to LCD panel surface)

Operation Condition : ±45° (perpendicular to LCD panel surface)

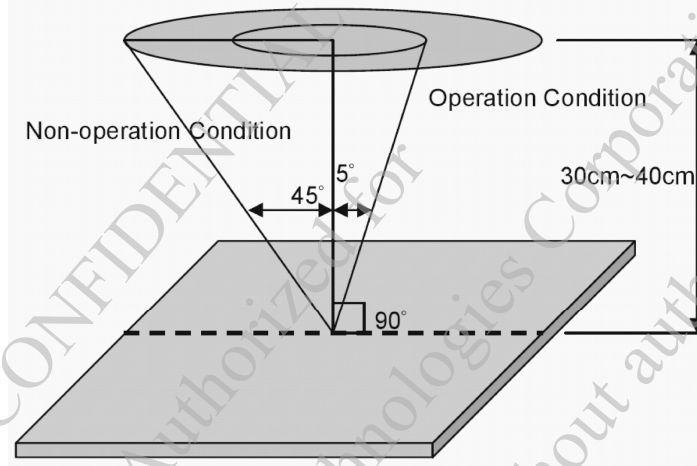

12.2.2 Environment Conditions :

Ambient Temperature		20°C~25°C
Ambient Humidity		65±20%RH
Ambient Illumination	Cosmetic Inspection	More than 600Lux
	Functional Inspection	300~500 Lux

12.2.3 Inspection lot

Quantity per delivery lot for each model

12.2.4 Inspection method

A sampling inspection shall be made according to the following provisions to judge The acceptability

(a)Applicable standard : MIL-STD-105E

Normal inspection, single sampling

Level II

(b)AQL : Major defect : AQL 0.65

Minor defect : AQL 1.0

12.3 INSPECTION STANDARDS

12.3.1 VISUAL DEFECTS CLASSIFICATION

TYPE OF DEFECT	INSPECTION ITEM	DEFECT FEATURE	AQL
MAJOR DEFECT	1.DISPLAY ON	<ul style="list-style-type: none"> • DEFECT TO MISS SPECIFIED DISPLAY FUNCTION, FOR ALL AND SPECIFIED DOTS EX: DISCONNECTION, SHORT CIRCUIT ETC 	0.65
	2.BACKLIGHT	<ul style="list-style-type: none"> • NO LIGHT • FLICKERING AND OTHER ABNORMAL ILLUMINATION 	
	3.DIMENSIONS	<ul style="list-style-type: none"> • SUBJECT TO INDIVIDUAL ACCEPTANCE SPECIFICATIONS 	
MINOR DEFECT	1.DISPLAY ZONE	<ul style="list-style-type: none"> • BLACK/WHITE SPOT • BUBBLES ON POLARIZER • NEWTON RING • BLACK/WHITE LINE • SCRATCH • CONTAMINATION • LEVER COLOR SPREED 	1.0
	2.BEZEL ZONE	<ul style="list-style-type: none"> • STAINS • SCRATCHES • FOREIGN MATTER 	
	3.SOLDERING	<ul style="list-style-type: none"> • INSUFFICIENT SOLDER • SOLDERED IN INCORRECT POSITION • CONVEX SOLDERING SPOT • SOLDER BALLS • SOLDER SCRAPS 	
	4.DISPLAY ON (ALL ON)	<ul style="list-style-type: none"> • LIGHT LINE 	

12.3.2 MODULE DEFECTS CALSSIFICATION

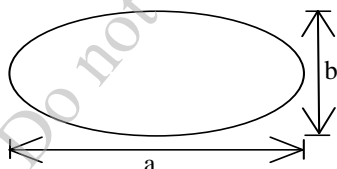
NO.	ITEM	CRITERIA												
1.	DISPLAY ON INSPECTION	(1)INCORRECT PATTERN (2)MISSING SEGMENT (3)DIM SEGMENT (4)OPERATING VOLTAGE BEYOND SPEC												
2.	OVERALL DIMENSIONS	(1)OVERALL DIMENSION BEYOND SPEC												
3.	DOT DEFECT	(1) INSPECTION PATTERN: FULL WHITE, FULL BLACK, RED, GREEN AND BLUE SCREENS. (2) <table border="1" style="margin-left: 20px;"> <thead> <tr> <th>ITEMS</th> <th>ACCEPTABLE COUNT</th> </tr> </thead> <tbody> <tr> <td>BRIGHT DOT</td> <td>$N \leq 3$</td> </tr> <tr> <td>DARK DOT</td> <td>$N \leq 5$</td> </tr> <tr> <td>TOAL BRIGHT AND DARK DOTS</td> <td>$N \leq 5$</td> </tr> </tbody> </table> <p>NOTE :</p> <p>1. THE DEFINITION OF DOT : THE SIZE OF A DEFECTIVE DOT OVER 1/2 OF WHOLE DOT IS REGARDED AS ONE DEFECTUVE DOT.</p> <p>2. BRIGHT DOT : DOTS APPEAR BRIGHT AND UNCHANGED IN SIZE IN WHICH LCD PANEL IS DISPLAYING UNDER BLACK PATTERN.</p> <p>3. DARK DOT : DOTS APPEAR DARK AND UNCHANGED IN SIZE IN WHICH LCD PANEL IS DISPLAYING UNDER PURE RED, GREEN, BLUE PICTURE.</p>	ITEMS	ACCEPTABLE COUNT	BRIGHT DOT	$N \leq 3$	DARK DOT	$N \leq 5$	TOAL BRIGHT AND DARK DOTS	$N \leq 5$				
ITEMS	ACCEPTABLE COUNT													
BRIGHT DOT	$N \leq 3$													
DARK DOT	$N \leq 5$													
TOAL BRIGHT AND DARK DOTS	$N \leq 5$													
4.	FOREIGN BLACK/WHITE/ BRIGHT LINE/ SCRATCH OF VIEWING AREA	<table border="1" style="margin-left: 20px;"> <thead> <tr> <th>LENGTH : L</th> <th>WIDTH : W</th> <th>PERMISSIBLE NO.</th> </tr> </thead> <tbody> <tr> <td>$L \leq 0.3$</td> <td>$W \leq 0.05$</td> <td>IGNORE</td> </tr> <tr> <td>$0.3 < L \leq 2.5$</td> <td>$0.05 < W \leq 0.1$</td> <td>4</td> </tr> <tr> <td>$2.5 < L$</td> <td>$0.1 < W$</td> <td>NONE</td> </tr> </tbody> </table> <p>WIDTH : W mm, LENGH : L mm</p>	LENGTH : L	WIDTH : W	PERMISSIBLE NO.	$L \leq 0.3$	$W \leq 0.05$	IGNORE	$0.3 < L \leq 2.5$	$0.05 < W \leq 0.1$	4	$2.5 < L$	$0.1 < W$	NONE
LENGTH : L	WIDTH : W	PERMISSIBLE NO.												
$L \leq 0.3$	$W \leq 0.05$	IGNORE												
$0.3 < L \leq 2.5$	$0.05 < W \leq 0.1$	4												
$2.5 < L$	$0.1 < W$	NONE												
5.	FOREIGN MATTER \ BLACK SPOTS \ WHITE SPOTS \ DENT (INCLUDING LIGHT LEAKAGE DUE TO POLARIZING PLATES PINHOLES, ETC.)	<table border="1" style="margin-left: 20px;"> <thead> <tr> <th>AVERAGE DIAMETER (mm): D</th> <th>NUMBER OF PIECES PERMITTED</th> </tr> </thead> <tbody> <tr> <td>$D \leq 0.15$</td> <td>IGNORE</td> </tr> <tr> <td>$0.15 < D \leq 0.5$</td> <td>4</td> </tr> <tr> <td>$0.5 < D$</td> <td>NONE</td> </tr> </tbody> </table> <p>NOTE : DIAMETER $D=(a+b)/2$</p> 	AVERAGE DIAMETER (mm): D	NUMBER OF PIECES PERMITTED	$D \leq 0.15$	IGNORE	$0.15 < D \leq 0.5$	4	$0.5 < D$	NONE				
AVERAGE DIAMETER (mm): D	NUMBER OF PIECES PERMITTED													
$D \leq 0.15$	IGNORE													
$0.15 < D \leq 0.5$	4													
$0.5 < D$	NONE													

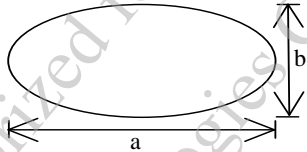
NO.	ITEM	CRITERIA		
			AVERAGE DIAMETER (mm) : D	NUMBER OF PIECES PERMITTED
6.	BUBBLES OF POLARIZER /DIRT/CF FAIL /SURFACE STAINS	BUBBLE ON THE POLARIZER	$D \leq 0.25$	IGNORE
			$0.25 < D \leq 0.5$	$N \leq 5$
			$0.5 < D$	NOTE
		SURFACE STATUS	$D < 0.1 \text{ mm}$	IGNORE
			$0.1 < D \leq 0.3\text{mm}$	$N \leq 3$
		CF FAIL / SPOT	$D < 0.1 \text{ mm}$	IGNORE
$0.1 < D \leq 0.3\text{mm}$	$N \leq 3$			
		<p>NOTE : (1)POLARIZER BUBBLE IS DEFINED AS THE BUBBLE APPEARS ON ACTIVE DISPLAY AREA. THE DEFECT OF POLARIZER BUBBLE SHALL BE IGNORED IF THE POLARIZER BUBBLE APPEARS ON THE OUTSIDE OF ACTIVE DISPLAY AREA.</p> <p>(2)THE EXTRANEIOUS SUBSTANCE IS DEFINED AS IT CAN BE OBSERVED WHEN THE MODULE IS POWER ON.</p> <p>(3)THE DEFINITION OF AVERAGE DIAMETER, D IS DEFINED AS FOLLOWING.</p> <p>AVERAGE DIAMETER (D)=(a+b)/2</p> 		
7.	LINE DEFECT ON DISPLAY	OBVIOUS VERTICAL OR HORIZONTAL LINE DEFECT IS NOT ALLOW		
8.	MURA ON DISPLAY	IT'S OK IF MURA IS SLIGHT VISIBLE THROUG 6% ND FILTER		
9.	UNEVEN COLOR SPREAD, COLORATION	(1)TO BE DETERMINED BASED UPON THE STANDARD SAMPLE.		
10.	BEZEL APPEARANCE	(1)BEZEL MAY NOT HAVE RUST, BE DEFORMED OR HAVE FINGER PRINTS STAINS OF OTHER CONTAMINATION. (2)BEZEL MUST COMPLY WITH JOB SPECIFICATIONS.		
11	PCB	<p>(1)THERE MAY NOT BE MORE THAN 2mm OF SEALANT OUTSIDE THE SEAL AREA ON THE PCB, AND THERE SHOULD BE NO MORE THAN THREE PLACES.</p> <p>(2)NO OXIDATION OR CONTAMINATION PCB TERMINALS.</p> <p>(3)PARTS ON PCB MUST BE THE SAME AS ON THE PRODUCTION CHARACTERISTIC CHART. THERE SHOULD BE NO WRONG PARTS, MISSING PARTS OR EXCESS PARTS.</p> <p>(4)THE JUMPER ON THE PCB SHOULD CONFORM TO THE PRODUCT CHARACTERISTIC CHART.</p> <p>(5)IF SOLDER GETS ON BEZEL TAB PADS, LED PAD, ZEBRA PAD OR SCREW HOLD PAD; MAKE SURE IT IS SMOOTHED DOWN.</p>		

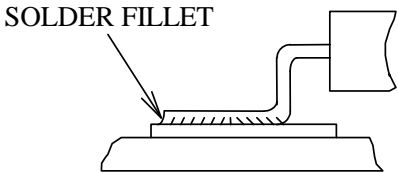
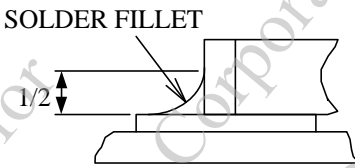
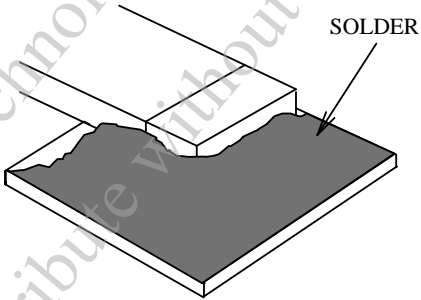
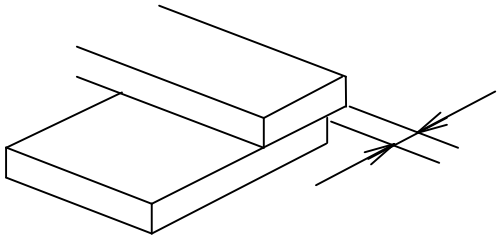
NO.	ITEM	CRITERIA
12.	SOLDERING	<p>(1)NO SOLDERING FOUND ON THE SPECIFIED PLACE</p> <p>(2)INSUFFICIENT SOLDER</p> <p>(a)LSI, IC A POOR WETTING OF SOLDER IS BETWEEN LOWER BEND OR "HEEL" OF LEAD AND PAD</p>  <p>(b)CHIP COMPONENT • SOLDER IS LESS THAN 50% OF SIDES AND FRONT FACE WETTING</p>  <p>• SOLDER WETS 3 SIDES OF TERMINAL, BUT LESS THAN 25% OF SIDES AND FRONT SURFACE AREA ARE COVERED</p>  <p>(3)PARTS ALIGMENT</p> <p>(a)LSI, IC LEAD WIDTH IS MORE THAN 50% BEYOND PAD OUTLINE</p> 

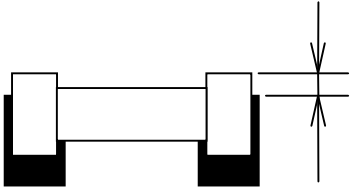
NO.	ITEM	CRITERIA
12.	SOLDERING	<p>(b)CHIP COMPONENT COMPONENT IS OFF CENTER, AND MORE THAN 50% OF THE LEADS IS OFF THE PAD OUTLINE</p>  <p>(4)NO UNMELTED SOLDER PASTE MAY BE PRESENT ON THE PCB. (5)NO COLD SOLDER JOINTS, MISSING SOLDER CONNECTIONS, OXIDATION OR ICICLE. (6)NO RESIDUE OR SOLDER BALLS ON PCB. (7)NO SHORT CIRCUITS IN COMPONENTS ON PCB.</p>
13.	BACKLIGHT	<p>(1)NO LIGHT (2)FLICKERING AND OTHER ABNORMAL ILLUMINATION (3)SPOTS OR SCRATCHES THAT APPEAR WHEN LIT MUST BE JUDGED USING LCD SPOT, LINES AND CONTAMINATION STANDARDS. (4)BACKLIGHT DOESN'T LIGHT OR COLOR IS WRONG.</p>
14.	GENERAL APPEARANCE	<p>(1)NO OXIDATION, CONTAMINATION, CURVES OR, BENDS ON INTERFACE PIN (OLB) OF TCP. (2)NO CRACKS ON INTERFACE PIN (OLB) OF TCP. (3)NO CONTAMINATION, SOLDER RESIDUE OR SOLDER BALLS ON PRODUCT. (4)THE IC ON THE TCP MAY NOT BE DAMAGED, CIRCUITS. (5)THE UPPERMOST EDGE OF THE PROTECTIVE STRIP ON THE INTERFACE PIN MUST BE PRESENT OR LOOK AS IF IT CAUSE THE INTERFACE PIN TO SEVER. (6)THE RESIDUAL ROSIN OR TIN OIL OF SOLDERING (COMPONENT OR CHIP COMPONENT) IS NOT BURNED INTO BROWN OR BLACK COLOR. (7)SEALANT ON TOP OF THE ITO CIRCUIT HAS NOT HARDENED. (8)PIN TYPE MUST MATCH TYPE IN SPECIFICATION SHEET. (9)LCD PIN LOOSE OR MISSING PINS. (10)PRODUCT PACKAGING MUST THE SAME AS SPECIFIED ON PACKAGING SPECIFICATION SHEET. (11)PRODUCT DIMENSION AND STRUCTURE MUST CONFORM TO PRODUCT SPECIFICATION SHEET. (12)THE APPEARANCE OF HEAT SEAL SHOULD NOT ADMIT ANY DIRT AND BREAK.</p>

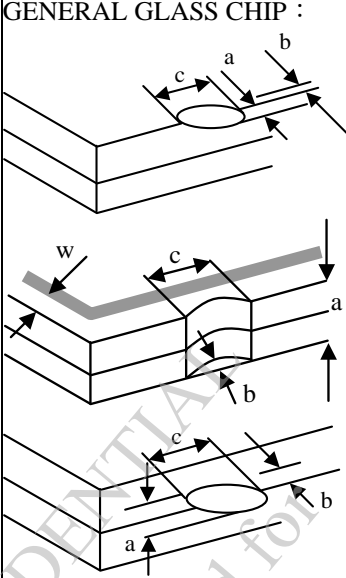
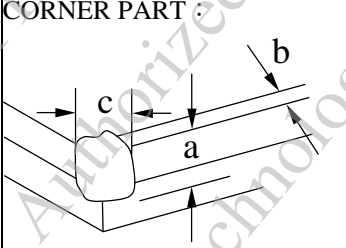
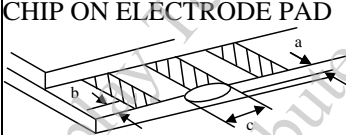
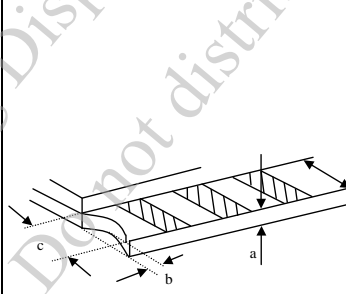
NO.	ITEM	CRITERIA									
15.	CRACKED GLASS	<p>THE LCD WITH EXTENSIVE CRACK IS NOT ACCEPTABLE</p> <p>GENERAL GLASS CHIP :</p>  <table border="1"> <thead> <tr> <th>a</th> <th>b</th> <th>c</th> </tr> </thead> <tbody> <tr> <td>$\leq t/2$</td> <td>< VIEWING AREA</td> <td>$\leq 1/8X$</td> </tr> <tr> <td>$t/2 > , \leq 2t$</td> <td>$\leq W/2$</td> <td>$\leq 1/8X$</td> </tr> </tbody> </table> <p>*W=DISTANCE BETWEEN SEALANT AREA AND LCD PANEL EDGE X = LCD SIDE LENGTH t = GLASS THICKNESS</p>	a	b	c	$\leq t/2$	< VIEWING AREA	$\leq 1/8X$	$t/2 > , \leq 2t$	$\leq W/2$	$\leq 1/8X$
		a	b	c							
		$\leq t/2$	< VIEWING AREA	$\leq 1/8X$							
		$t/2 > , \leq 2t$	$\leq W/2$	$\leq 1/8X$							
		<p>CORNER PART :</p>  <table border="1"> <thead> <tr> <th>a</th> <th>b</th> <th>c</th> </tr> </thead> <tbody> <tr> <td>$\leq t/2$</td> <td>< VIEWING AREA</td> <td>$\leq 1/8X$</td> </tr> <tr> <td>$> t/2 , \leq 2t$</td> <td>$\leq W/2$</td> <td>$\leq 1/8X$</td> </tr> </tbody> </table> <p>*W=DISTANCE BETWEEN SEALANT AREA AND LCD PANEL EDGE X = LCD SIDE LENGTH t = GLASS THICKNESS</p>	a	b	c	$\leq t/2$	< VIEWING AREA	$\leq 1/8X$	$> t/2 , \leq 2t$	$\leq W/2$	$\leq 1/8X$
a	b	c									
$\leq t/2$	< VIEWING AREA	$\leq 1/8X$									
$> t/2 , \leq 2t$	$\leq W/2$	$\leq 1/8X$									
<p>CHIP ON ELECTRODE PAD</p>  <table border="1"> <thead> <tr> <th>a</th> <th>b</th> <th>c</th> </tr> </thead> <tbody> <tr> <td>$\leq t$</td> <td>$\leq 0.5\text{mm}$</td> <td>$\leq 1/8X$</td> </tr> </tbody> </table> <p>* X=LCD SIDE WIDTH t=GLASS THICKNESS</p>	a	b	c	$\leq t$	$\leq 0.5\text{mm}$	$\leq 1/8X$					
a	b	c									
$\leq t$	$\leq 0.5\text{mm}$	$\leq 1/8X$									
 <table border="1"> <thead> <tr> <th>a</th> <th>b</th> <th>c</th> </tr> </thead> <tbody> <tr> <td>$\leq t$</td> <td>$\leq 1/8X$</td> <td>$\leq L$</td> </tr> </tbody> </table> <p>*X=LCD SIDE WIDTH t = GLASS THICKNESS L=ELECTRODE PAD LENGTH</p> <p>①IF GLASS CHIPPING THE ITO TERMINAL, OVER 2/3 OF THE ITO MUST REMAIN AND BE, INSPECTED ACCORDING TO ELECTRODE TERMINAL SPECIFICATIONS</p> <p>②IF THE PRODUCT WILL BE HEAT SEALED BY THE CUSTOMER, THE ALIGNMENT MARK MUST NOT BE DAMAGED</p>	a	b	c	$\leq t$	$\leq 1/8X$	$\leq L$					
a	b	c									
$\leq t$	$\leq 1/8X$	$\leq L$									

12.4 RELIABILITY TEST

12.4.1 STANDARD SPECIFICATIONS FOR RELIABILITY OF LCD MODULE

NO	ITEM	DESCRIPTION
1	HIGH TEMPERATURE OPERATION	THE SAMPLE SHOULD BE ALLOWED TO STAND AT +70°C FOR 240 HRS
2	LOW TEMPERATURE OPERATION	THE SAMPLE SHOULD BE ALLOWED TO STAND AT -20°C FOR 240 HRS
3	HIGH TEMPERATURE STORAGE	THE SAMPLE SHOULD BE ALLOWED TO STAND AT +80°C FOR 240 HRS
4	LOW TEMPERATURE STORAGE	THE SAMPLE SHOULD BE ALLOWED TO STAND AT -30°C FOR 240 HRS
5	HIGH TEMP / HUMIDITY TEST STORAGE	THE SAMPLE SHOULD BE ALLOWED TO STAND AT 60°C, 90% RH 240 HRS
6	THERMAL SHOCK (NOT OPERATED)	THE SAMPLE SHOULD BE ALLOWED TO STAND THE FOLLOWING 10 CYCLES OF OPERATION: -30°C FOR 30 MINUTES ~ +80°C FOR 30 MINUTES
7	ESD (ELECTROSTATIC DISCHARGE) (NOT OPERATED)	AIR DISCHARGE ± 12KV CONTACT DISCHARGE ± 8KV

NOTE (1) : THE TEST SAMPLES HAVE RECOVERY TIME FOR 2 HOURS AT ROOM TEMPERATURE BEFORE THE FUNCTION CHECK. IN THE STANDARD CONDITIONS, THERE IS NO DISPLAY FUNCTION NG ISSUE OCCURRED.

12.5 TESTING CONDITIONS AND INSPECTION CRITERIA

FOR THE FINAL TEST THE TESTING SAMPLE MUST BE STORED AT ROOM TEMPERATURE FOR 24 HOURS, AFTER THE TESTS LISTED IN TABLE 12.5, STANDARD SPECIFICATIONS FOR RELIABILITY HAVE BEEN EXECUTED IN ORDER TO ENSURE STABILITY.

NO	ITEM	TEST MODEL	INSPECTION CRITERIA
1	CURRENT CONSUMPTION	REFER TO SPECIFICATION	THE CURRENT CONSUMPTION SHOULD CONFORM TO THE PRODUCT SPECIFICATION.
2	CONTRAST	REFER TO SPECIFICATION	AFTER THE TESTS HAVE BEEN EXECUTED, THE CONTRAST MUST BE LARGER THAN HALF OF ITS INITIAL VALUE PRIOR TO THE TESTS.
3	APPEARANCE	VISUAL INSPECTION	DEFECT FREE

12.6 OPERATION

- 12.6.1 DO NOT CONNECT OR DISCONNECT MODULES TO OR FROM THE MAIN SYSTEM WHILE POWER IS BEING SUPPLIED .
- 12.6.2 USE THE MODULE WITHIN SPECIFIED TEMPERATURE ; LOWER TEMPERATURE CAUSES THE RETARDATION OF BLINKING SPEED OF THE DISPLAY ; HIGHER TEMPERATURE MAKES OVERALL DISPLAY DISCOLOR. WHEN THE TEMPERATURE RETURNS TO NORMALITY, THE DISPLAY WILL OPERATE NORMALLY .
- 12.6.3 ADJUST THE LC DRIVING VOLTAGE TO OBTAIN THE OPTIMUM CONTRAST.
- 12.6.4 POWER ON SEQUENCE INPUT SIGNALS SHOULD NOT BE SUPPLIED TO LCD MODULE BEFORE POWER SUPPLY VOLTAGE IS APPLIED AND REACHES THE SPECIFIED VALUE .
IF ABOVE SEQUENCE IS NOT FOLLOWED , CMOS LSIS OF LCD MODULES MAY BE DAMAGED DUE TO LATCH - UP PROBLEM .
- 12.6.5 NOT ALLOWED TO INFLICT ANY EXTERNAL STRESS AND TO CAUSE ANY MECHANICAL INTERFERENCE ON THE BENDING AREA OF FPC DURING THE TAIL BENDING BACKWARDS!
DO NOT STRESS FPC AND IC ON THE MODULE!

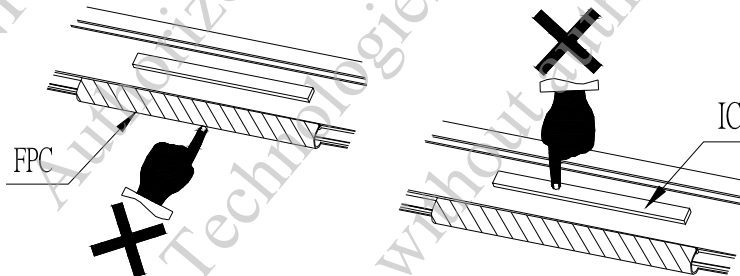

12.7 NOTICE

- 12.7.1 USE A GROUNDED SOLDERING IRON WHEN SOLDERING CONNECTOR I/O TERMINALS . FOR SOLDERING OR REPAIRING, TAKE PRECAUTION AGAINST THE TEMPERATURE OF THE SOLDERING IRON AND THE SOLDERING TIME TO PREVENT PEELING OFF THE THROUGH-HOLE-PAD .
- 12.7.2 DO NOT DISASSEMBLE . EDT SHALL NOT BE HELD RESPONSIBLE IF THE MODULE IS DISASSEMBLED AND UPON THE REASSEMBLY THE MODULE FAILED .
- 12.7.3 DO NOT CHARGE STATIC ELECTRICITY , AS THE CIRCUIT OF THIS MODULE CONTAINS CMOS LSIS. A WORKMAN'S BODY SHOULD ALWAYS BE STATIC-PROTECTED BY USE OF AN ESD STRAP. WORKING CLOTHES FOR SUCH PERSONNEL SHOULD BE OF STATIC-PROTECTED MATERIAL .
- 12.7.4 ALWAYS GROUND THE ELECTRICALLY-POWERED DRIVER BEFORE USING IT TO INSTALL THE LCD MODULE. WHILE CLEANING THE WORK STATION BY VACUUM CLEANER, DO NOT BRING THE SUCKING MOUTH NEAR THE MODULE ; STATIC ELECTRICITY OF THE ELECTRICALLY-POWERED DRIVER OR THE VACUUM CLEANER MAY DESTROY THE MODULE .
- 12.7.5 DON'T GIVE EXTERNAL SHOCK.
- 12.7.6 DON'T APPLY EXCESSIVE FORCE ON THE SURFACE.
- 12.7.7 LIQUID IN LCD IS HAZARDOUS SUBSTANCE. MUST NOT LICK AND SWALLOW.
WHEN THE LIQUID IS ATTACH TO YOUR, SKIN, CLOTH ETC.
WASH IT OUT THOROUGHLY AND IMMEDIATELY.
- 12.7.8 DON'T OPERATE IT ABOVE THE ABSOLUTE MAXIMUM RATING.
- 12.7.9 STORAGE IN A CLEAN ENVIRONMENT, FREE FROM DUST, ACTIVE GAS, AND SOLVENT.
- 12.7.10 STORE WITHOUT ANY PHYSICAL LOAD.
- 12.7.11 REWIRING: NO MORE THAN 3 TIMES.