

## NUMERICAL CONTROL

### What is N/C?

Probably the most universally accepted definition of numerical control is that offered by the Electronics Industries Association which defines it as: "A system in which actions are controlled by the direct insertion of numerical data at some point. The system must automatically interpret at least some portion of this." In a somewhat broader sense, numerical control may be considered as an extremely versatile means of automatically operating machines through the use of discrete numerical values introduced to the machine by some form of stored input medium such as a punched or magnetized tape. However, the real significance of numerical control lies beyond these definitions in the effects it has produced and is producing in almost every area of manufacturing, both direct and indirect. In fact, its influence has even begun to pervade the activities of the engineering product designer.

### History

As with many inventions, it came into being because of a need for manufacturing a product by a far simpler method than then existed. The U.S. Air Force found itself in this position shortly after World War II when it was faced with the complex machining of aircraft components and inspection fixtures to close accuracies on a repeatable basis. During this period Mr. John T. Parsons had been working on a project for development equipment that would machine flat templates for inspecting the contour of helicopter blades. A proposal covering a machine to prepare these templates was presented to the Air Force by the Parsons Corporation of Traverse City, Michigan, and resulted in a development contract in 1948. In 1949 Parsons was joined by MIT as a major subcontractor on the project. Development work continued, and in 1951 MIT was awarded the prime contract which resulted in the successful demonstration, in 1952, of a three-motion milling machine. The following

three years were largely devoted to hardware refinements and mathematical techniques for tape preparation. After studying the applicability of numerical control machining for high-speed aircraft structures, the Aerospace Industries Association, an organization comprised of aerospace manufacturers, recommended to the Air Force that forthcoming machines be equipped with numerical controls and in 1955 the Air Force began awarding some 35 million dollars for the manufacture of approximately 100 numerically controlled milling machines. A significant number of these were large contour skin-milling machines measuring up to 45 feet in length, and costing almost a half million dollars. All of these machines are still actively producing aircraft and missile components, many on a three-shift seven-day week basis. Credit is undoubtedly due to the Air Force planners for their prophetic decision.

It was not until approximately 1960 that numerical control began to appear on a reasonably wide commercial scale. At that time the trend of equipment procurement was heavily weighted toward the less expensive point-to-point variety such as is utilized with drill presses rather than the more complicated form of continuous-path control used with milling operations. The growth in the number of numerically controlled machines, while not phenomenal, has been accelerating rapidly; and as of December 1969 it was estimated that there were more than 15,600 numerically controlled machines operating throughout the industry. Approximately 85 per cent of these are of the point-to-point variety although approximately 40 per cent of the dollars invested have been for the contouring or continuous-path type. It is expected that as more and more companies feel the competitive pressure of those utilizing this equipment, the rate of acceptance will increase substantially; and numerically controlled machine tools will represent a far greater share of the total dollar value of machine cutting tools. We would be remiss, however, if only the machine tool industry were considered in the future growth of

numerical control. Applications such as drafting and inspection are fast gaining prominence. Literally, any mechanism requiring controlled motion is a candidate for numerical control. Also, the figures noted above are strictly domestic and the growths of numerical control in western Europe and Japan, while lagging the United States, are expected to increase sharply as a result of the recognition of this foreign market potential by machine tool and numerical control systems builders.

#### Point-to-Point

This form of numerical control is usually associated with equipment that performs operations at specific positions and does not affect the work-piece when moving from one point to the next. Undoubtedly, the most common example of a point-to-point numerically controlled machine tool is a simple drill press. The cutting tool or part is directed to specific points and, after arriving at the proper position, the machine tool automatically performs its drilling operation. After the hole has been drilled, the spindle then automatically moves to the next position. The exact path that the spindle takes in moving from point to point is immaterial, providing, of course, the time required is reasonable and the spindle does not collide with either the part or holding fixture. In accordance with the coded tape instructions, the drill would be moved to a position directly over the center of the hole to be drilled. Once in position, the drill is automatically lowered, at a predetermined speed and feed which may be mechanically set at the start of the machining cycle or regulated from coded instructions on the tape. After drilling hole A, the head moves out of the hole at a rapid retract rate. The drill then moves to point B, and the cycle is repeated. The same sequence is followed for holes C, D and E. After the completion of the last hole the drilling head may be instructed to return to the original starting point or to another parking position and automatically turn itself off. The drill, or head, may follow a right-

angle pattern in moving from A to B or it may move at a 45-degree angle until in line with the new position and then move directly to it along one axis.

The point-to-point concept is by no means restricted to drilling or even cutting applications. On a numerically controlled turret punch press the work-piece is automatically positioned under the selected punch which then automatically punches the proper size and shape hole. Indexing of the turret is automatic and prescribed by the tape. Operation of a tube bender consists of positioning the tube and then bending it to the proper angle.

#### Continuous-Path or Contouring Control

Unlike point-to-point numerical control whereby the movements of the path taken between operations is relatively unimportant, the route when considering a continuous-path application is of consequence since the work-piece is being affected throughout the entire movement. The cutting tool moves along the perimeter of the part and cuts metal continuously as it moves along its prescribed path. The entire travel must therefore be controlled to close accuracy both as to position and velocity. The control system or director, consequently, is more complicated and more costly.

To date milling machines have proven to be the most popular application of continuous-path numerical control.

Although not as numerous as numerically controlled milling machines the contour lathe is becoming increasingly popular. Set-up time as well as accuracy, and particularly finish, are improved significantly when compared to conventional-type tracing lathes. Tapers, plus arcs and other

curved cuts, in addition to automatic thread cutting are possible from tape commands.

As with point-to-point control, continuous-path control has numerous applications other than metal cutting. Although far more machines of the point-to-point variety have been and probably will be sold, there is every likelihood that the variety of continuous-path applications may exceed those of point-to-point, particularly in the non-manufacturing areas. A good example is the drafting machine. The director or control system is essentially the same as that used with a milling machine only in this instance the motions of a pen are being directed instead of a cutting tool. In fact, the compatibility of this control system has been extended to a point where a tape, prepared for a numerically controlled milling machine, may be handled on the control system for this drafting unit. The plot made by the drafting machine will describe the path which the cutter on the milling machine would follow. Among other uses this machine has been instrumental for checking out tapes prior to cutting material on a milling machine.

It is both possible and practical to utilize continuous-path controlled machines for performing point-to-point operations where point-to-point systems are restricted, in a practical sense, to point-to-point operations.

BREAKDOWN OF TOTAL U.S. FACTORY SHIPMENTS OF NUMERICAL AND  
OTHER TYPES OF AUTOMATIC MECHANICAL METALWORKING  
CONTROLS INTO ITS THREE MAJOR COMPONENTS  
(Values are in thousands of dollars)

Year	Total U.S. shipments of numerical & other types of controls		Shipments of point-to-point positioning NC				Shipments of continuous path NC				Dial or plug-board type of prerecorded control				
	Total units	Total value	As % of total		Average value per unit		As % of total		Average value per unit		Units	Value	As % of total		
			units	value	value	unit	units	value	value	unit			Units	Value	Value
1964	1,517	\$29,224	1,145	75.5%	\$14,965	51.2%	(\$13.1K)	172	11.3%	\$11,231	38.4%	(\$65.3K)	200	\$3,028	10.4%
1965	2,100	43,943	1,604	76.4%	25,925	59.0%	(\$16.2K)	229	10.9%	13,845	31.5%	(\$60.5K)	267	4,173	9.5%
1966	2,939	55,485	2,044	69.6%	26,059	47.0%	(\$12.7K)	524	17.8%	22,923	41.3%	(\$43.7K)	371	6,503	11.7%
1967	2,957	69,364	2,050	69.3%	36,085	52.0%	(\$17.6K)	621	21.0%	27,298	39.4%	(\$44.0K)	286	5,981	8.6%
1968	2,870	80,861	1,734	60.4%	33,040	41.8%	(\$19.5K)	965	33.6%	43,803	54.2%	(\$45.4K)	171	3,218	4.0%
-----															
1st half 1969	1,293	\$36,283	744	57.6%	\$14,752	40.7%	(\$19.8K)	471	36.4%	\$20,060	55.3%	(\$42.6K)	78	\$1,471	4.0%

Source: U.S. Dept. of Commerce, Metalworking Machinery (Series MQ-35W) 1964-1st half of 1969.

TEK'S CONTROL - WHAT WE OFFER - NOW AND IN THE FUTURE

Now- 2 or 3 axis contouring/positioning OEM price -25% less than list

STANDARD FEATURES

MDI

Linear interpolation

Single block

.0001" resolution, 240 IPM feedrate

300 CPS reader

Trailing zero only programming (leading zeros optional)

EIA code, word address, absolute position programming

Direct (IPM) feedrate programming

Full floating zero

Sequence number readout

Position & command readout

CRT display (with scaling) (with 611 or 601 accessory) of tool cutler path for quick tape check plus hard copy with 4601

Rugged designed unit with 4 layer P.C. cards to insure noise immunity

Ease of servicing due to functionally designed P.C. cards & easy accessability to all circuitry

Smallest control with features not found in larger, more expensive controls

OPTIONAL FEATURES

Jog Control

Mirror image

Feedrate override

Zero seek

Tape reader with larger spools

Circular interpolation

Post processors for most N/C languages including APT.  
Additional 'M' function decoding (miscellaneous functions)  
s & t function decoding (spindle speed & tool selection)  
g 80 series - canned cycles for tapping, drilling, boring  
Servo amplifiers, motors & feedback encoders  
ASC II code programming

#### FUTURE PRODUCTS

Tape verification unit - March 1970  
Lathe control (C.S.F.M. & thread cutting) - Summer 1970  
Point-to-Point control - (less expensive) - Spring 1970

#### USERS OF N/C

Drilling equipment (includes P.C. board drills)  
Lathes, chuckers, bar machines, engine lathes  
Milling machines - horizontal & vertical plus drilling/boring/  
milling-machining centers  
Punch presses  
Wirewrap  
Component insertion  
Tube bending  
Drafting machines  
Routers - P.C. board, wood etc.

#### CUSTOMERS

##### OEM'S

Mfgr's. of n/c'd equipment  
Retrofit houses  
Machinery distributors - import & domestic



**END USERS**

Machine shops at virtually all large manufacturing companies including aerospace and electronics houses

Government controlled machine shops - example: Naval Air Rework Facilities

Any company that would use equipment listed under "uses of N/C"

**HOW DO WE MARKET N/C?**

**COMPETITION & MARKETPLACE**

Control manufacturers & dollar volume percentage of the U.S. numerical control market.

General Electric	- 47%
Bendix	- 14%
Allen Bradley	- 7% (Bunker Ramo)

others

Westinghouse  
Hughes  
Superior Electric  
Cincinnati Milacron  
Pratt & Whitney

Discuss service policies & start-up assistance

Open vs. closed loop controls absolute vs. incremental programming.  
Resolvers, encoders (incremental & absolute)

TYPES OF TAPE CODES

Word Address

Tab Sequential

Fixed Sequential

ADDRESS CHARACTERS

X,Y,Z - motion words (dimension)

a,b,c - angular dimensions about X,Y & Z axis

i,j,k - circle centerpoint dimensions when  
using circular interpolation

f - feedrate

g - preparatory functions

m - miscellaneous functions

n - sequence number

r - rapid traverse

s - spindle speed

t - tool selection

TAPE VERIFICATION UNIT (T.V.U.) (1700)

Single block - variable block rate

Sequence # search

Data display of g,f,s,t,m,x,y,z,r,i,j,k

611 screen size 1.56" to 200" in 5 or 6 steps (selectable)

4 quadrant programming (+) & (-) commands

Offset (screen) of 9 positions

Absolute or incremental (selectable)

Word address or tab sequential (selectable)

Leading or trailing zero programming needed (selectable)

EIA, ASCII, or ISO codes - (selectable)

Resolution .0001", .001" or .01 MM selectable

Large spool tape reader

+Beam finder-beam inhibit-remote erase-remote print on 4601

Optional MDI & tape punch for editing- available in future

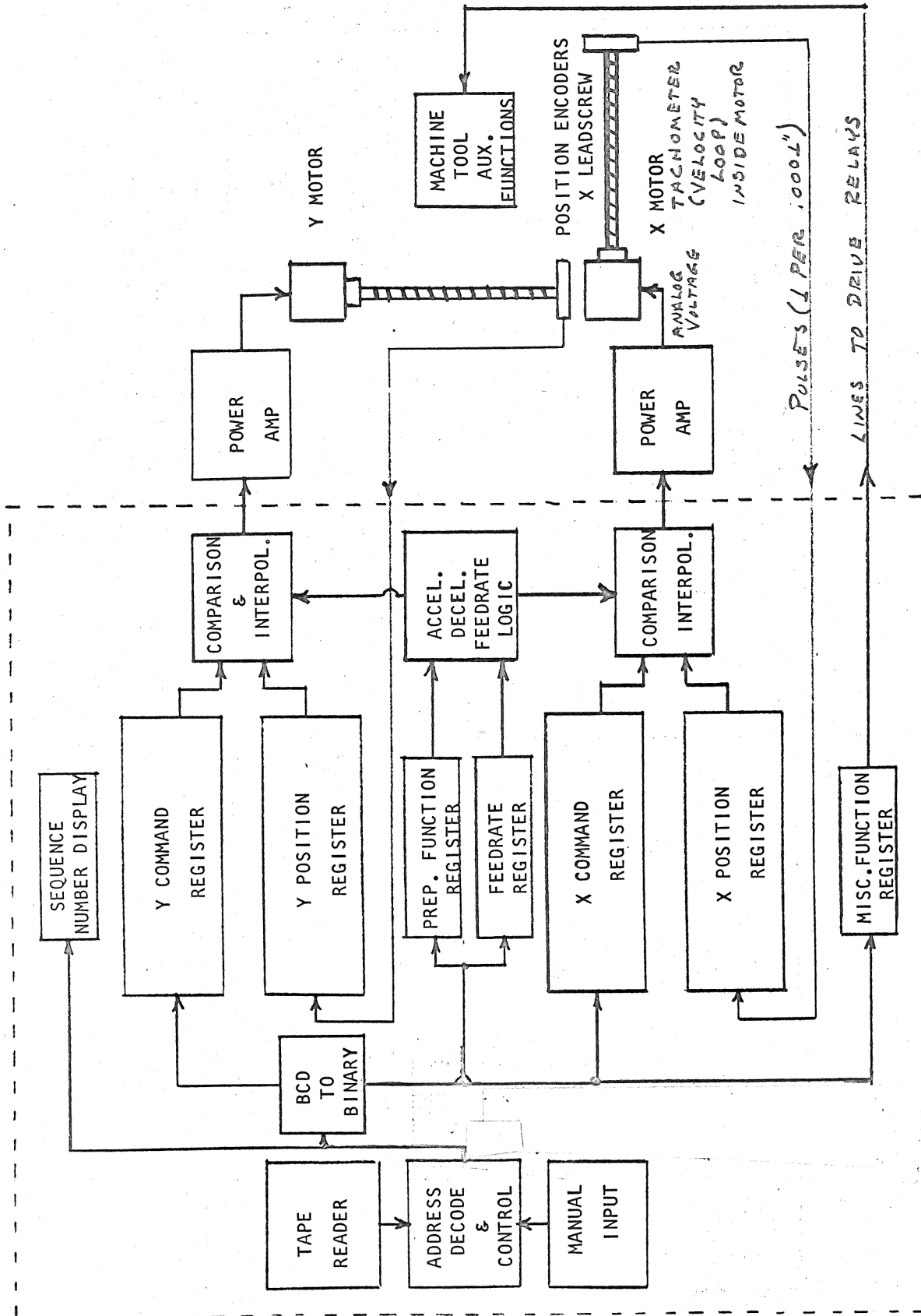

N.C. SYSTEM SIMPLIFIED BLOCK DIAGRAM

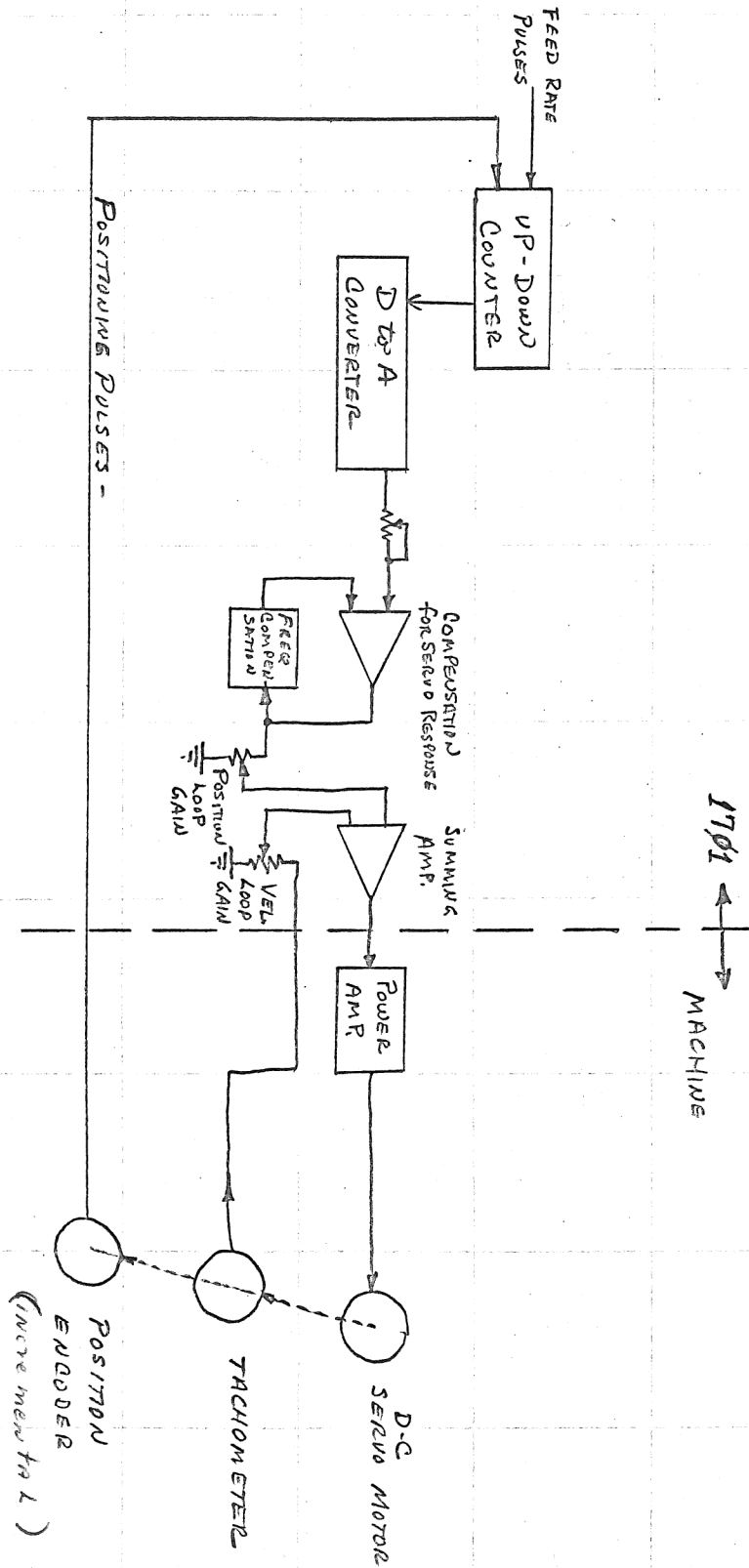

SERVO SYSTEM BLOCK DIAGRAM

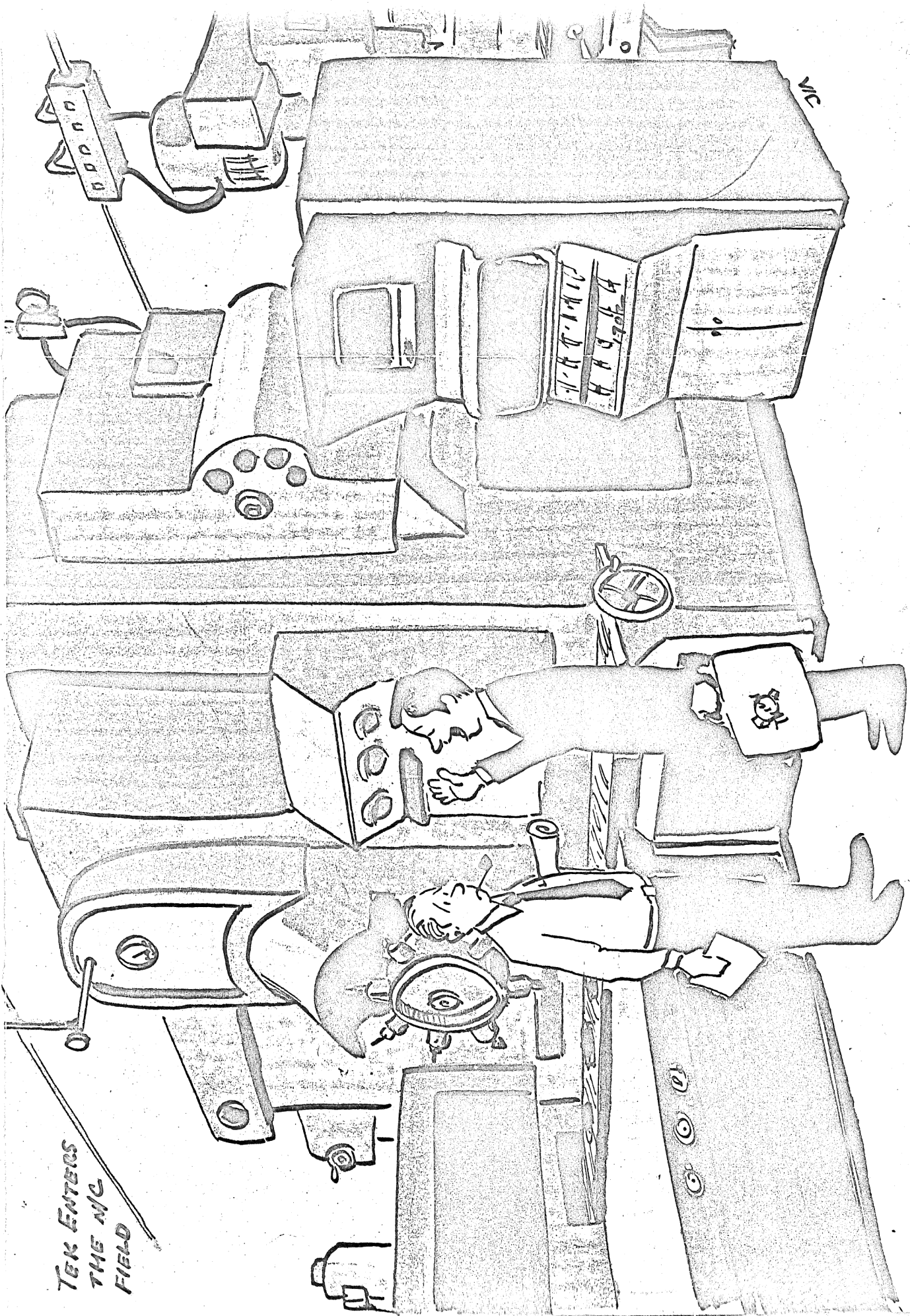

TEK ENTERS  
THE M.C.  
FIELD

Service? You bet! Just send her to your local Tektronix service center. We'll give it a bath, tweak it up and have it right back.