

TABLE OF CONTENTS

2	Notes
3	Power Supply
4	Connectors to CPU board
5	Board ID and Expanded IO
6	Ethernet
7	UARTs and IrDA
8	Ext. UART and USB OTG
9	DIP Switches and Keypad
10	Touch Panel Connector
11	SD/MMC and LCD Connector
12	Heart Beat and Reset
13	Extension and CSI connectors
14	Codec
15	Unused Gates

REVISIONS

ZONE	REV	DESCRIPTION	DATE	APPROVED
	X1	- First Draft - The schematic was changed from S11402_E. - IrDA Transceiver (U16) was changed from Agilent HSDL-3602-007 to HSDL-3220-001. After this change, R37, C56, C57 and C61 are changed. - USB mini AB connector (P4) was changed to Molex 51387-0578.	30-Sept-05	
	X2	- Changed RP8 from 10K to 33K	03-Jan-06	
	A	- Release to pilot run	May-06	
	B	- Fixed the pin duplication in U17, pin 32. - Fixed the footprint in P6	25-July-06	

FREESCALE RESERVES THE RIGHT TO MAKE CHANGES WITHOUT FURTHER NOTICE TO ANY PRODUCTS HERE IN IMPROVE RELIABILITY, FUNCTION, OR DESIGN. MOTOROLA DOES NOT ASSUME ANY LIABILITY ARISING OUT OF THE APPLICATION OR USE OF ANY PRODUCT OR CIRCUIT DESCRIBED HEREIN.



Designed by: Eddie Lee	Date: 30-Sept-2005	Title: M9328MX21ADS Base Board - ECO Compliant			
Drawn by: Eddie Lee	Date: 30-Sept-2005				
Project lead:	Date:	Size C	Root: <Name5> Name: <Name6>	Document Number SCH-75839	Rev B
Product Specialist: Lee Kin Heng	Date: 30-Sept-2005	Last Modified: July 25, 2006			Sheet 1 of 15

NOTES:

1. UNLESS OTHERWISE SPECIFIED:
ALL RESISTORS ARE IN OHMS, 5%, 1/8 WATT.
ALL CAPACITORS ARE IN UF.
ALL VOLTAGE ARE DC.

2. INTERRUPTED LINES CODES WITH THE
SAME LETTER OR LETTER COMBINATIONS
ARE ELECTRICALLY CONNECTED.

3. DEVICE TYPE NUMBER IS FOR REFERENCE
ONLY. THE NUMBER VARIES WITH THE
MANUFACTURER.

4. SPECIAL SYMBOL USAGE:
_B DENOTES - ACTIVE LOW SIGNAL.
<> DENOTES - VECTORED SIGNALS.

5. INTERPRET DIAGRAM IN ACCORDANCE
WITH AMERICAN NATIONAL STANDARDS
INSTITUTE SPECIFICATIONS, CURRENT
REVISION, WITH THE EXCEPTION OF
LOGIC BLOCK SYMBOLOGY.

6. CODE FOR SHEET TO SHEET REFERENCES
IS AS FOLLOWS:

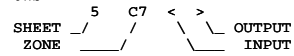

7. VCC LOCATIONS
UNLESS OTHERWISE SPECIFIED, VCC IS APPLIED TO:
PIN8 OF ALL 8-PIN ICS
PIN14 OF ALL 14-PIN ICS
PIN16 OF ALL 16-PIN ICS
PIN20 OF ALL 20-PIN ICS

8. GROUND LOCATIONS
PIN4 OF ALL 8-PIN ICS
PIN7 OF ALL 14-PIN ICS
PIN8 OF ALL 16-PIN ICS
PIN10 OF ALL 20-PIN ICS

Notes

Size	Root: <Name5>	Document Number	Rev
B	Name: <Name6>	SCH-75839	B
Last Modified: July 25, 2006		Sheet 2 of 15	

MAIN +5VDC POWER INPUT

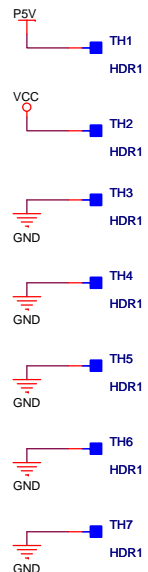
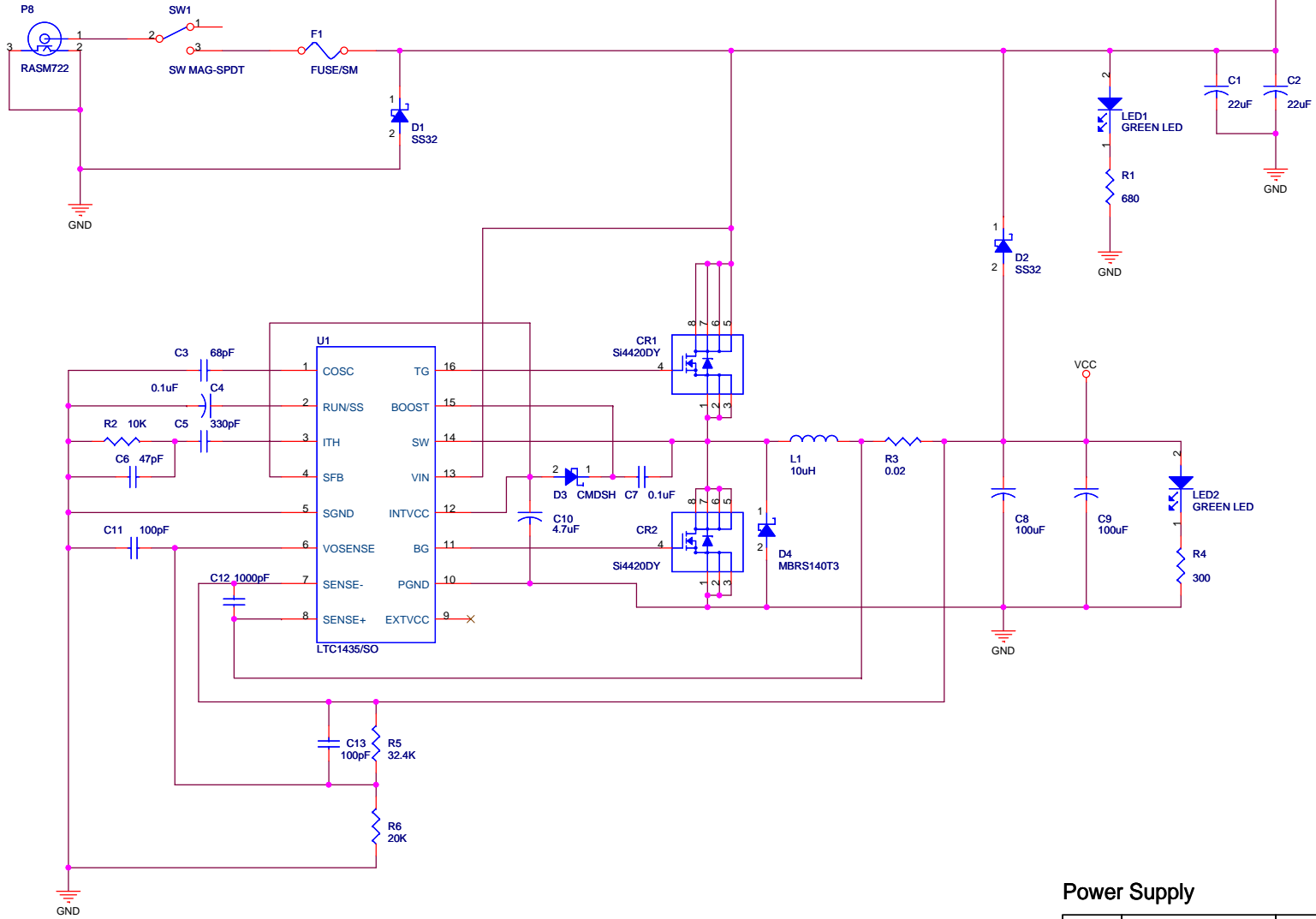

Power Supply

Size	Root: <Name5>	Document Number	Rev
B	Name: <Name6>	SCH-75839	B
Last Modified: July 25, 2006		Sheet 3 of 15	

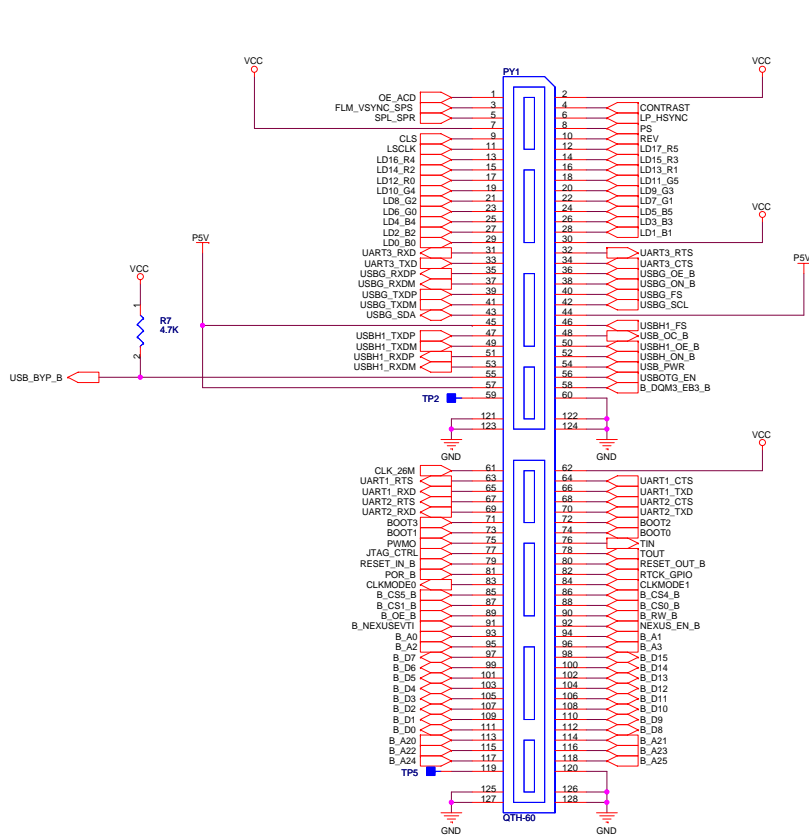

Un-used address and data pins are reserved by EVB

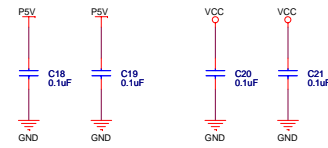
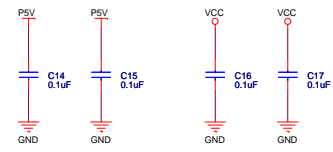
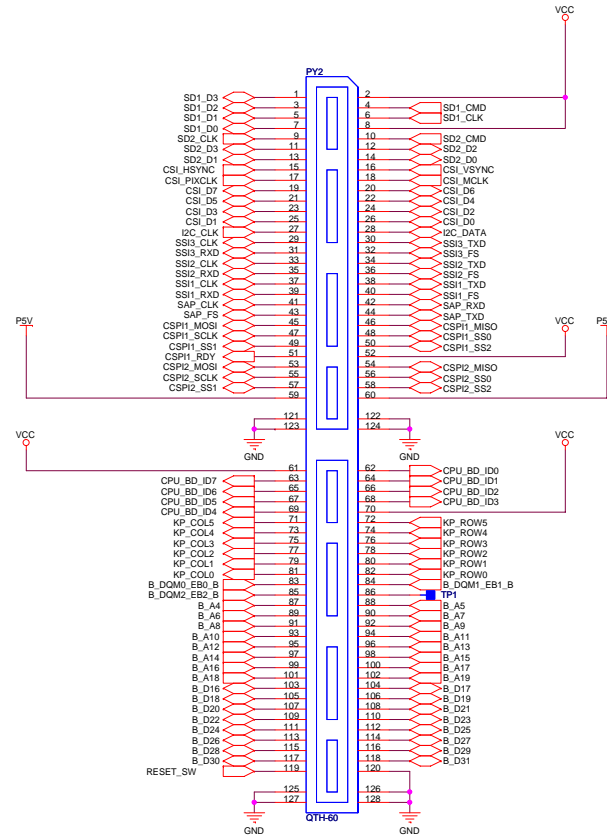

Connectors to CPU board

Size	Root: <Name5>	Document Number	Rev
C	Name: <Name6>	SCH-75839	B
Last Modified: July 25, 2006		Sheet 4 of 15	

Board ID

Address : 0xCC40 0000 (16 bit)

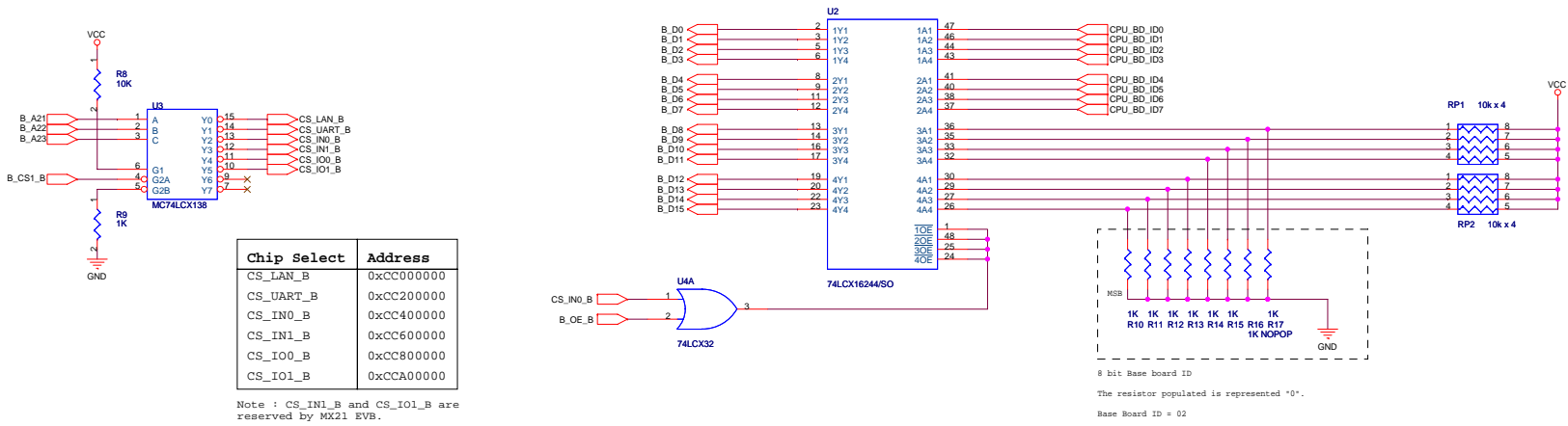

Expanded IO

Address : 0xCC80 0000 (16 bit)

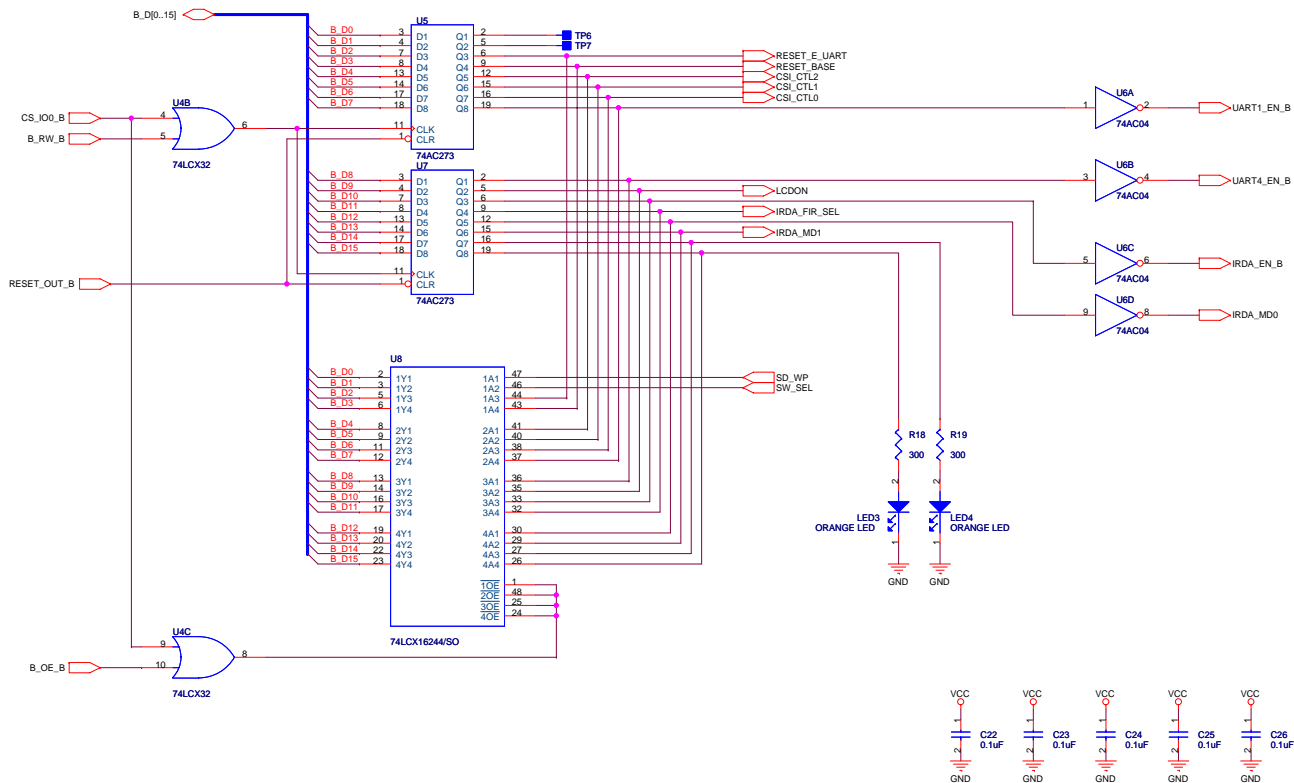

Board ID and Expanded IO

Size	Root: <Name5>	Document Number	Rev
C	Name: <Name6>	SCH-75839	B
Last Modified: July 25, 2006		Sheet 5 of 15	

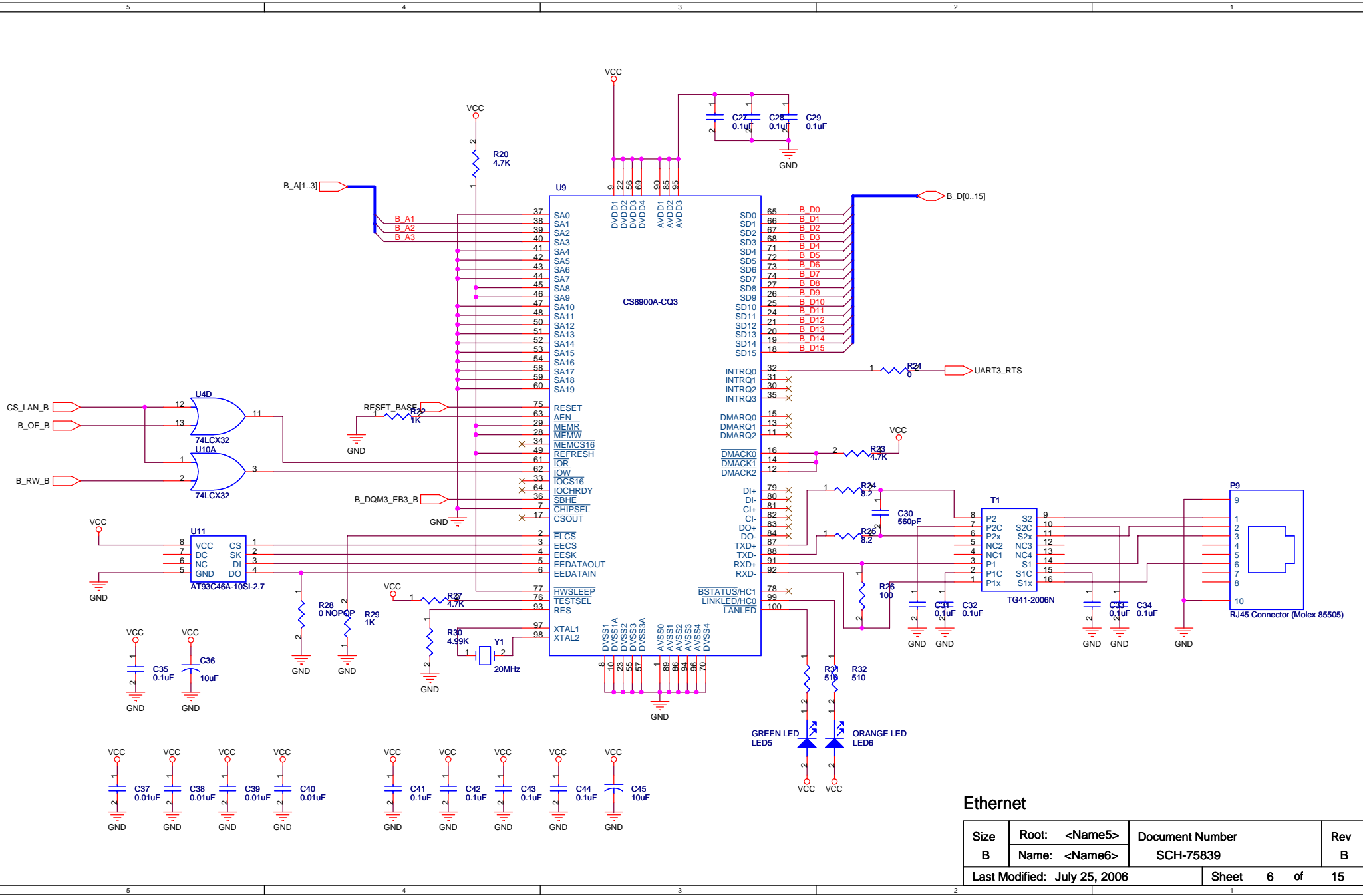

Ethernet

Size	Root: <Name5>	Document Number	Rev
B	Name: <Name6>	SCH-75839	B
Last Modified: July 25, 2006		Sheet 6 of 15	

UART1 (DCE)

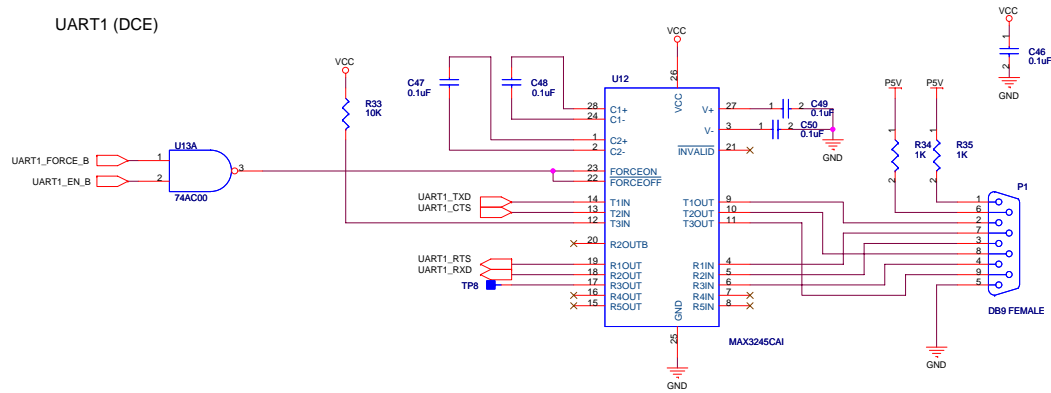

DCE		
1	CD	O
2	TX	O
3	RX	I
4	DTR	I
5	GND	
6	DSR	O
7	RTS	I
8	CTS	O
9	RI	O

UART4 (DTE)

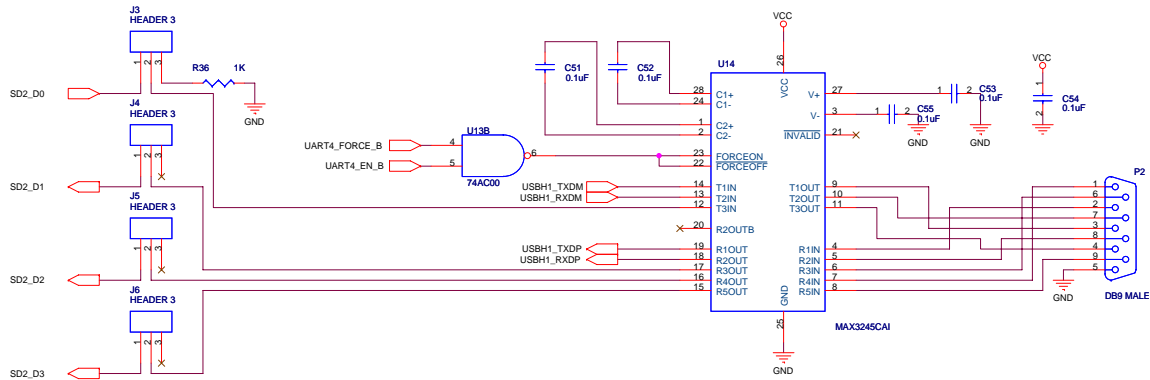

DTE		
1	CD	I
2	RX	I
3	TX	O
4	DTR	O
5	GND	
6	DSR	I
7	RTS	O
8	CTS	I
9	RI	I

IrDA

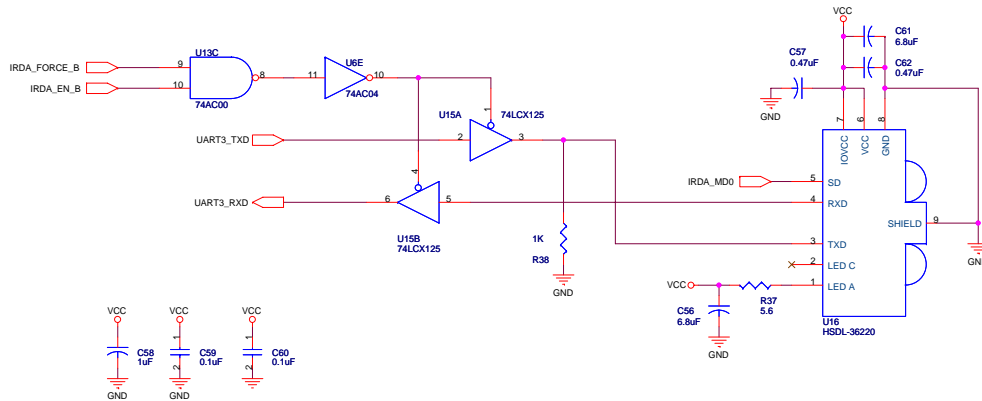

UARTs and IrDA

Size	Root: <Name5>	Document Number	Rev
C	Name: <Name6>	SCH-75839	B
Last Modified: July 25, 2006		Sheet 7 of 15	

Ext. UART (DCE)

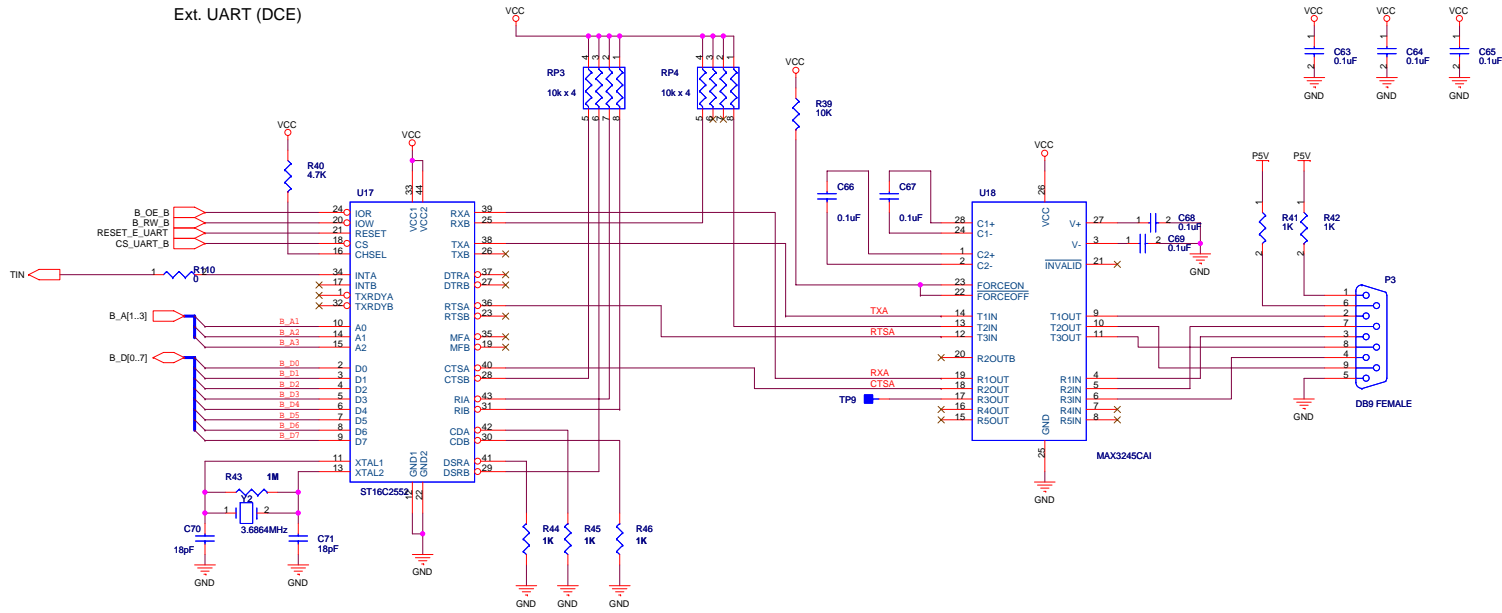

DCE		
1	CD	O
2	TX	O
3	RX	I
4	DTR	I
5	GND	
6	DSR	O
7	RTS	I
8	CTS	O
9	RI	O

USB OTG TRANSCEIVER

DIRECT I2C MODE:
I2C SLAVE ADDRESS
->0010 1101

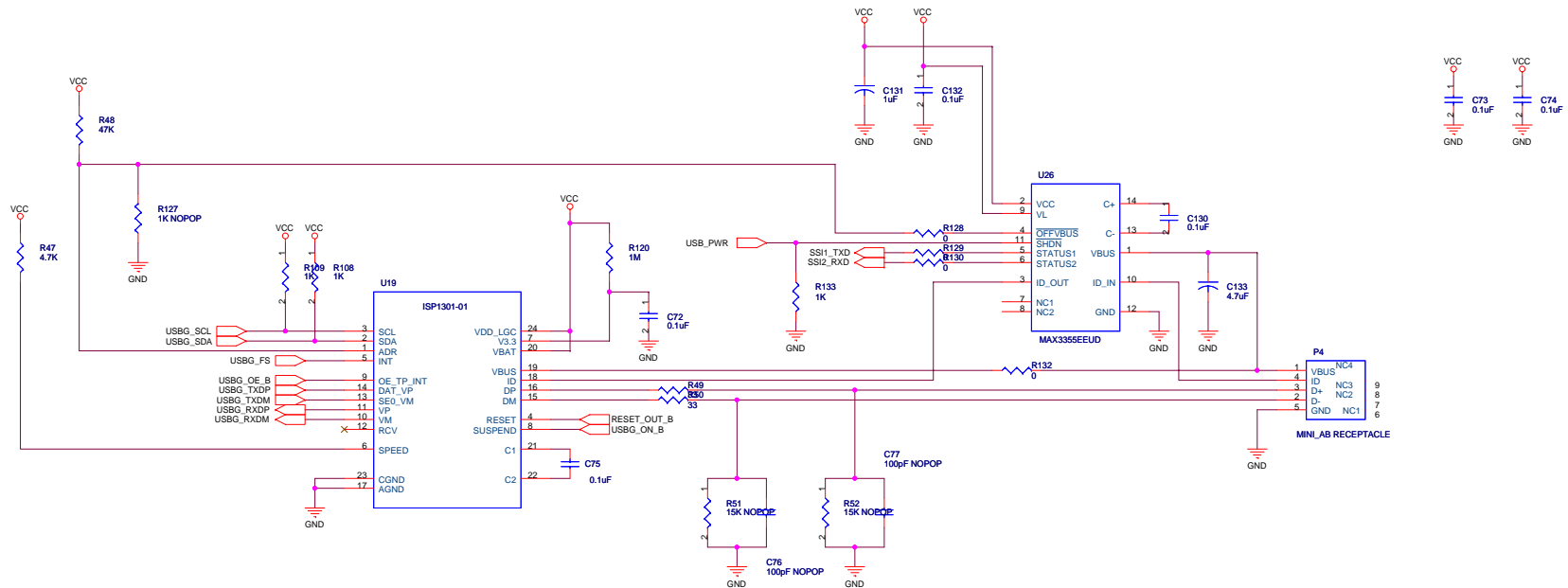

External UART and USB OTG

Size	Root:	<Name5>	Document Number	Rev
C	Name:	<Name6>	SCH-75839	B
Last Modified: July 25, 2006			Sheet 8 of 15	

Keypad Connector

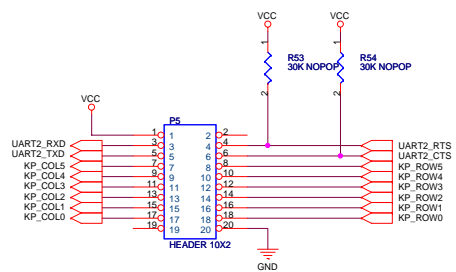

	Tahiti Version	
	V1.0/1.1	V2.0
UART2_RXD	KP_COL7	KP_ROW6
UART2_CTS	KP_ROW6	KP_COL7

DIP Switches

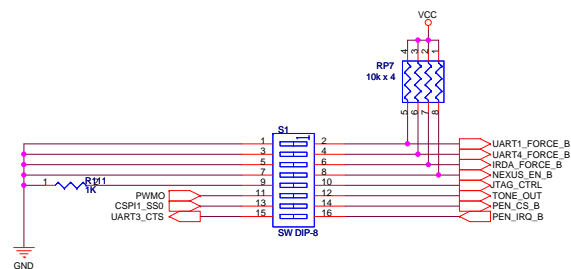
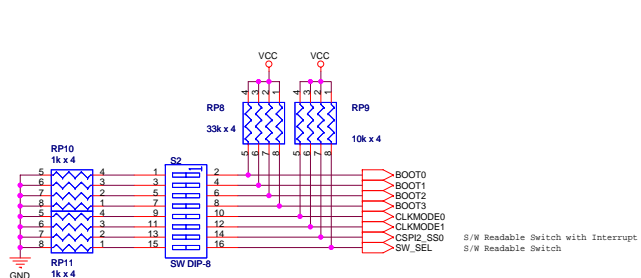

DIP Switches & Keypad

Size	Root: <Name5>	Document Number	Rev
C	Name: <Name6>	SCH-75839	B
Last Modified: July 25, 2006		Sheet 9 of 15	

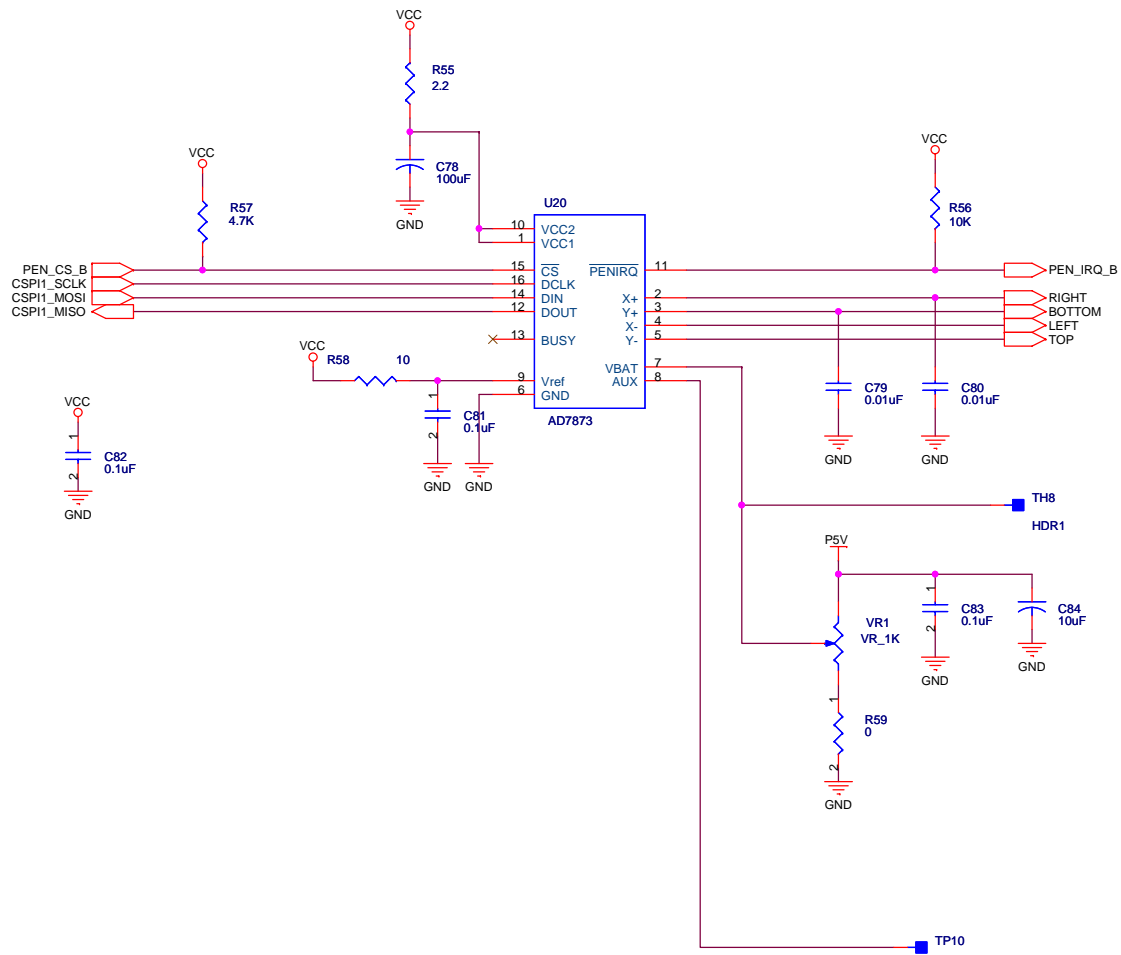

Touch Panel Controller

Size	Root: <Name5>	Document Number	Rev
B	Name: <Name6>	SCH-75839	B
Last Modified: July 25, 2006		Sheet	10 of 15

SD card

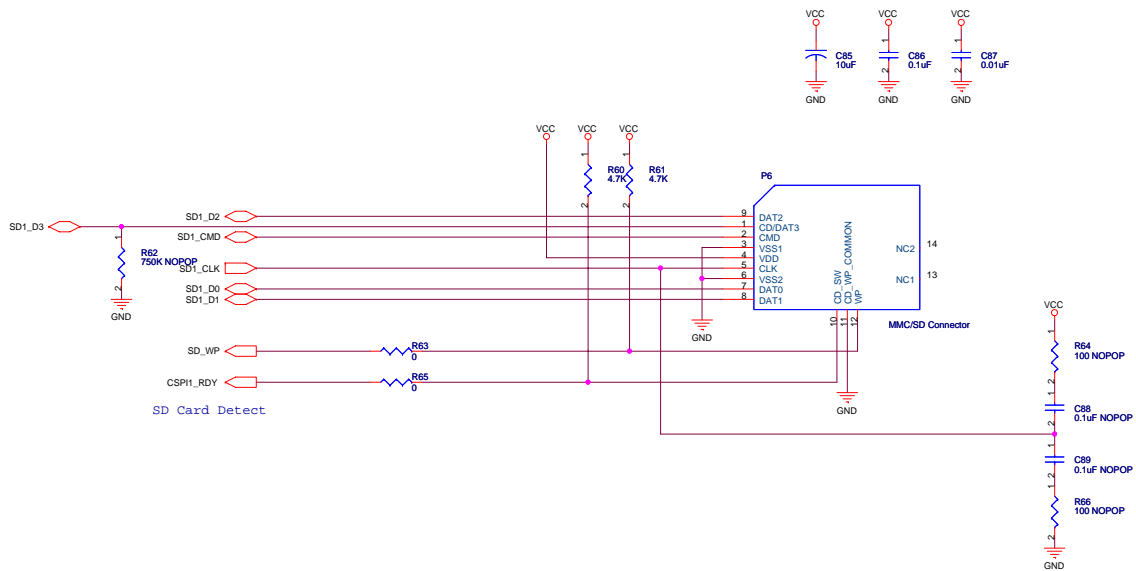

LCD Connector

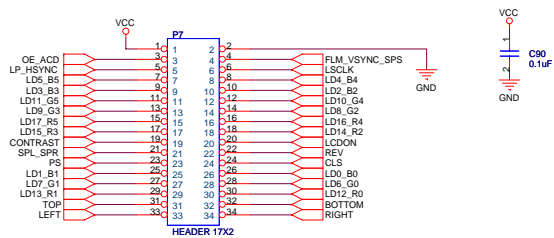

TV Encoder Connector

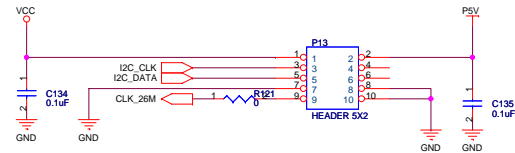

SD/MMC and LCD Connector

Size	Root: <Name5>	Document Number	Rev
C	Name: <Name6>	SCH-75839	B
Last Modified: July 25, 2006		Sheet 11 of	15

Heart Beat Circuit

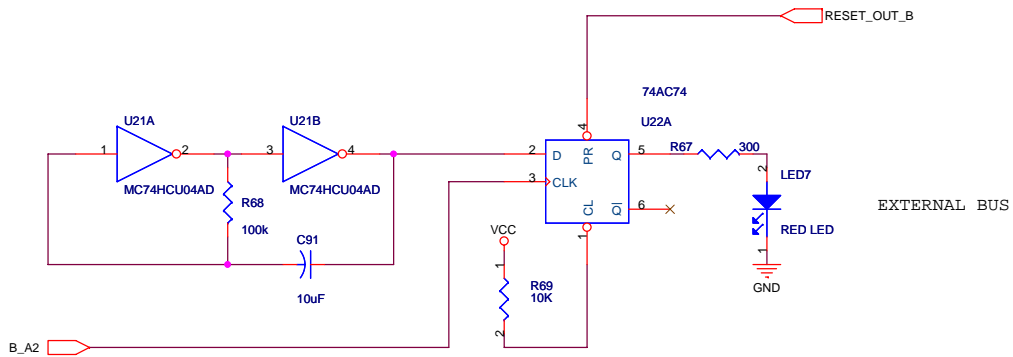

Reset Switch

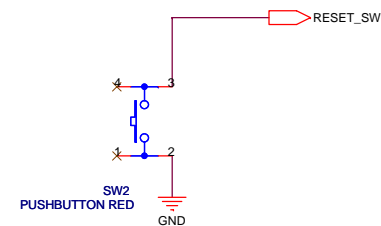

Buzzer

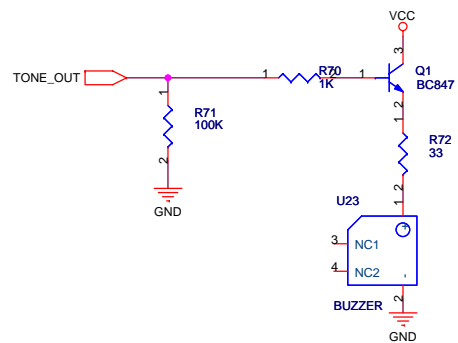

Heart Beat / Reset Switch / Buzzer

Size	Root: <Name5>	Document Number	Rev
B	Name: <Name6>	SCH-75839	B
Last Modified: July 25, 2006		Sheet 12 of 15	

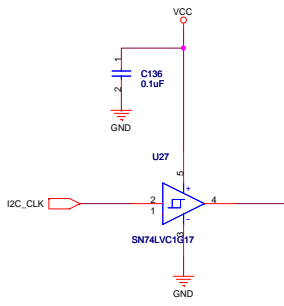

CSI Connector

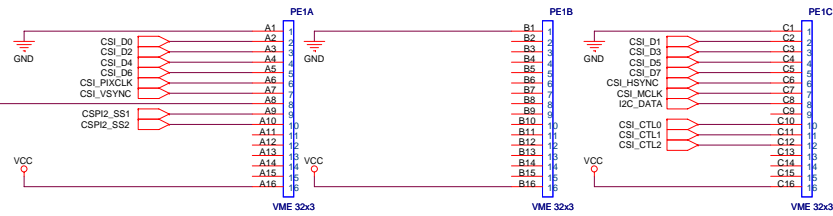

1 Wire Connector

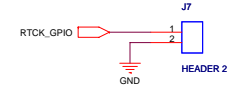
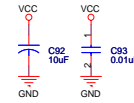

Extension Socket 1

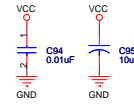
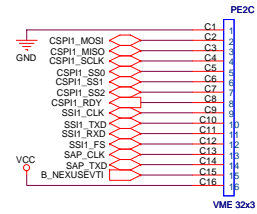
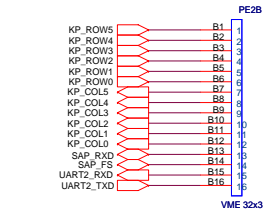
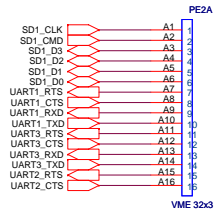

Extension Socket 2

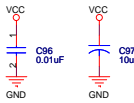
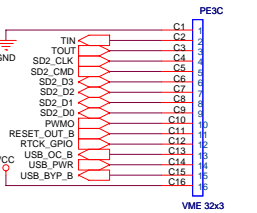
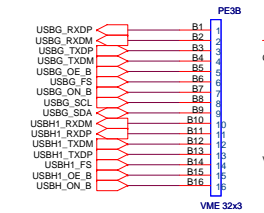
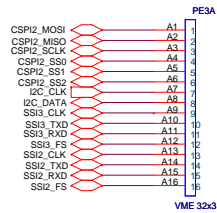

Extension / CSI connectors / 1 Wire Connector

Size	Root: <Name5>	Document Number	Rev
C	Name: <Name6>	SCH-75839	B
Last Modified: July 25, 2006		Sheet 13 of	15

CODEC

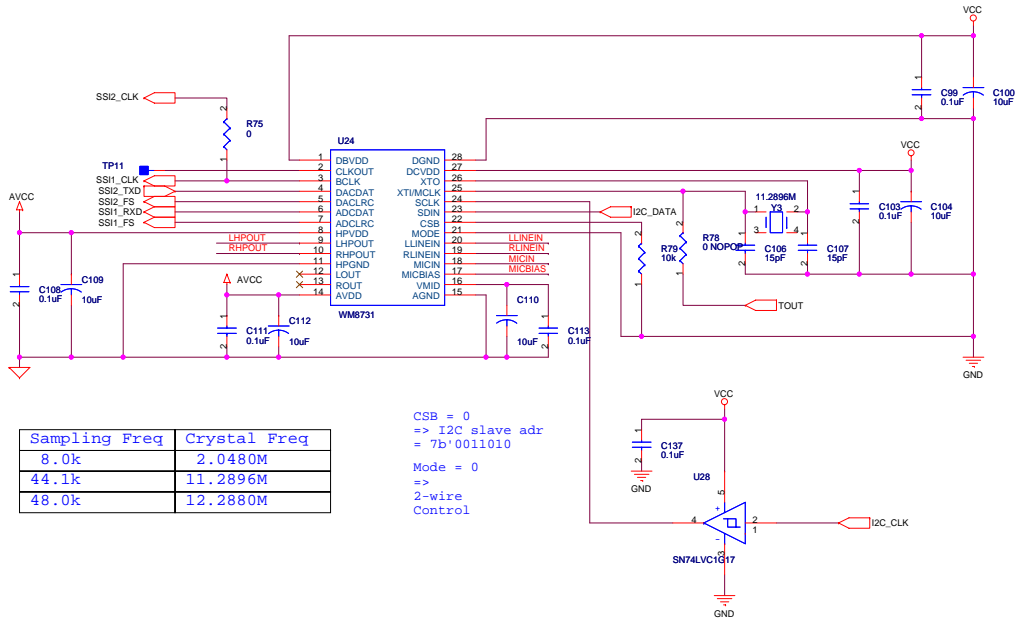

Sampling Freq	Crystal Freq
8.0k	2.0480M
44.1k	11.2896M
48.0k	12.2880M

CSB = 0
 => I2C slave adr = 7b'0011010
 Mode = 0
 =>
 2-wire Control

Power Supply Filter

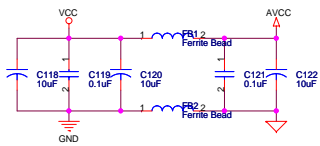

I2C pull up control

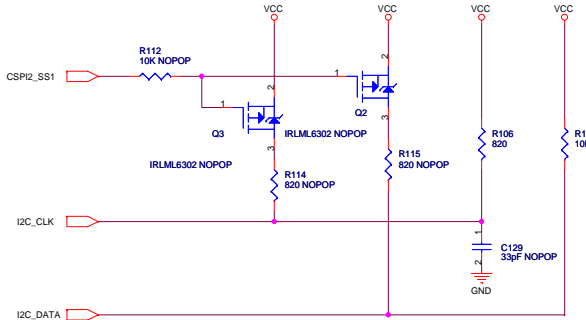

Input Ports

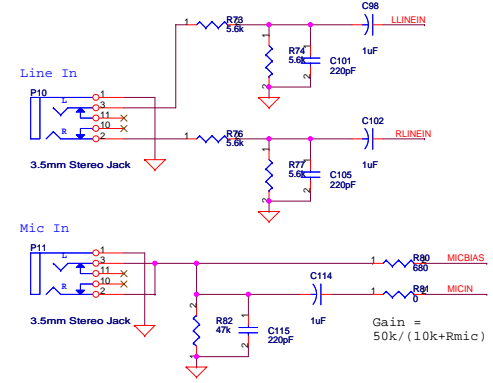

Line Out

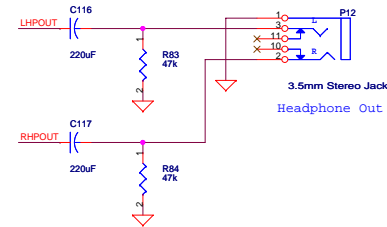

CODEC

Size	Root: <Name5>	Document Number	Rev
C	Name: <Name6>	SCH-75839	B
Last Modified: July 25, 2006		Sheet 14 of	15

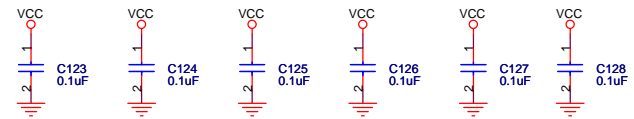
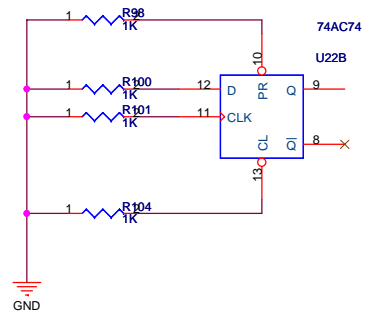
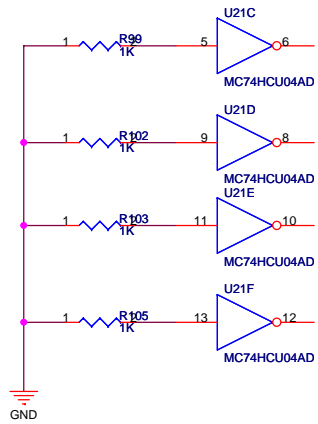
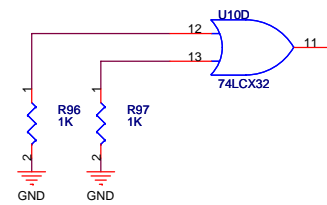
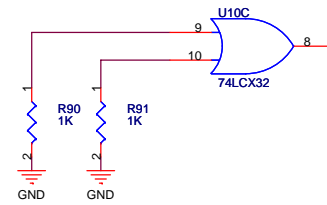
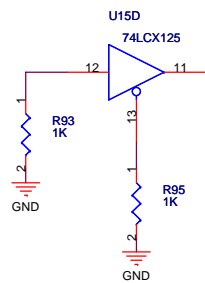
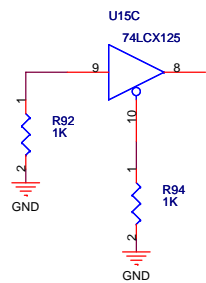
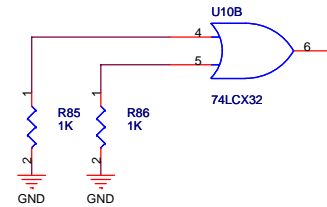
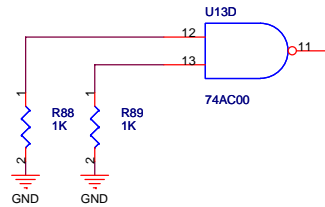
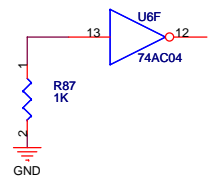

Unused Gates

Size	Root: <Name5>	Document Number	Rev
B	Name: <Name6>	SCH-75839	B
Last Modified: July 25, 2006		Sheet 15 of 15	