

M4POWER TMCM-30X M3POWER TMCM-30X M2POWER TMCM-30X M1POWER TMCM-30X

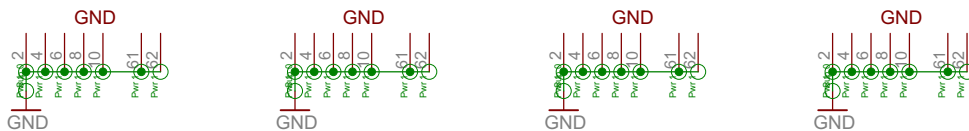

<h1>CP_Robot</h1>		HAREROD Marcus Hasenstab info@harerod.de	
TITLE: CP_Robot_12b		Power	
Document Number:		REV: V1.1	
Date: 15.11.2010 09:09:32		Sheet: 1/12	

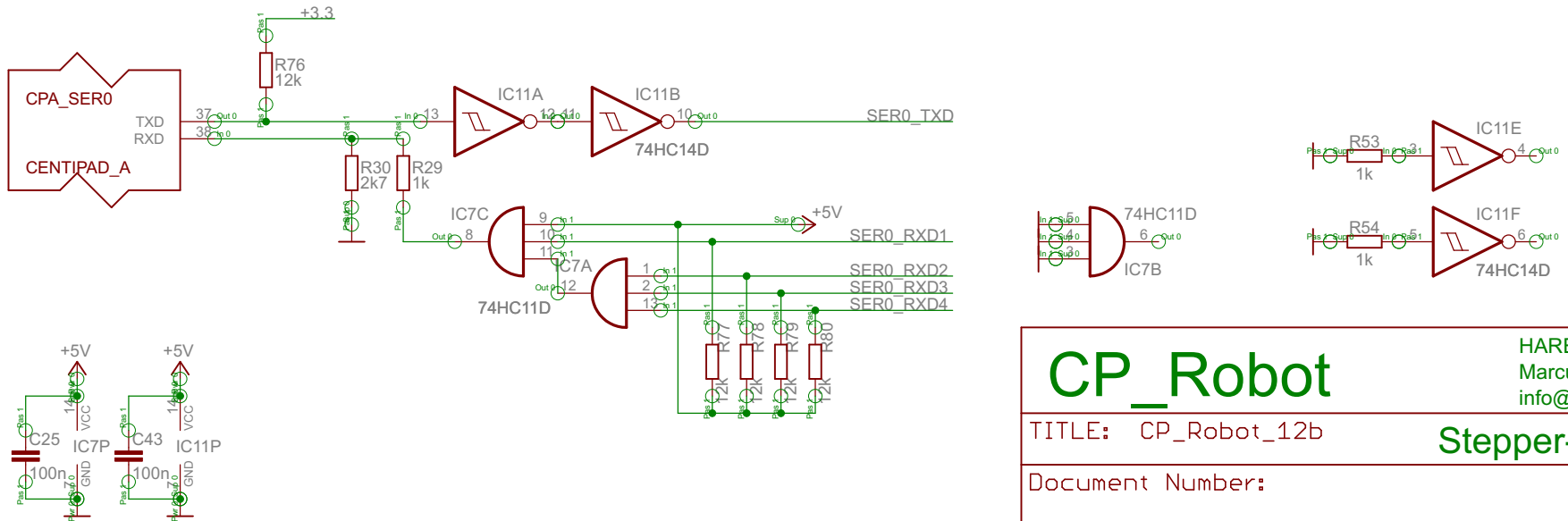
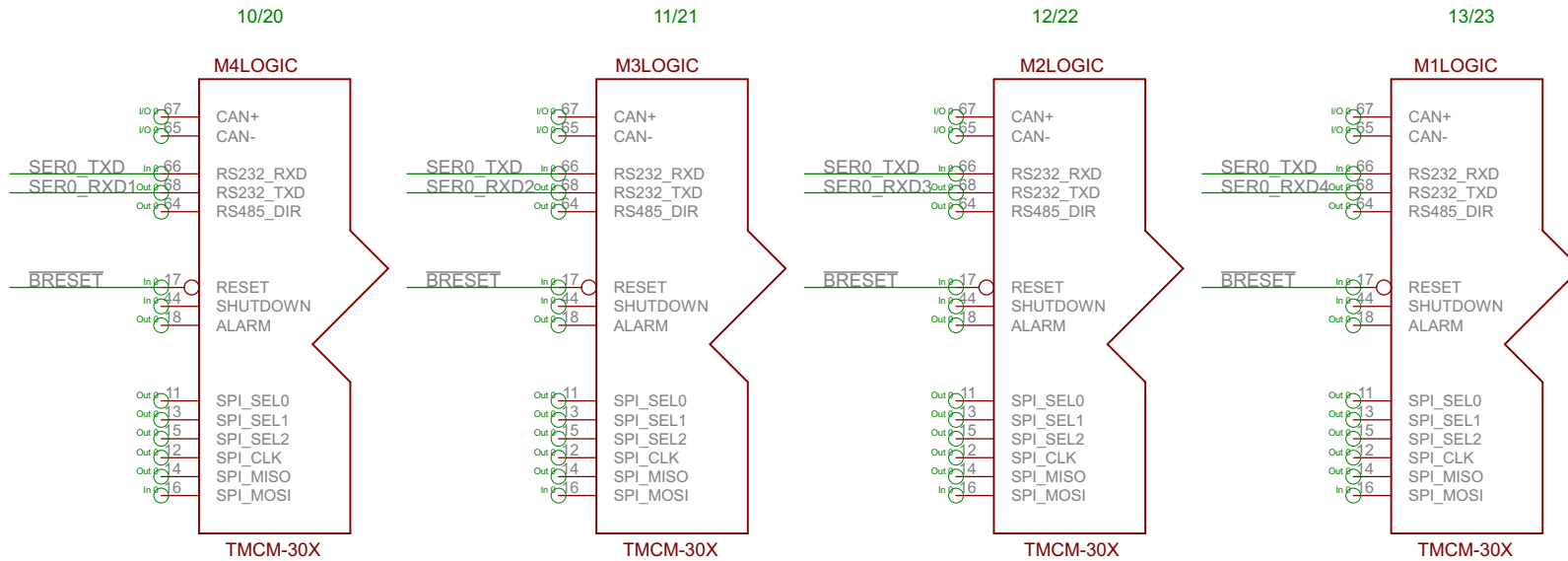

<h1>CP_Robot</h1>		HAREROD Marcus Hasenstab info@harerod.de	
TITLE: CP_Robot_12b		Stepper-Control	
Document Number:		REV: V1.1	
Date: 15.11.2010 09:09:32		Sheet: 2/12	

Adress 10 / 20

axis0

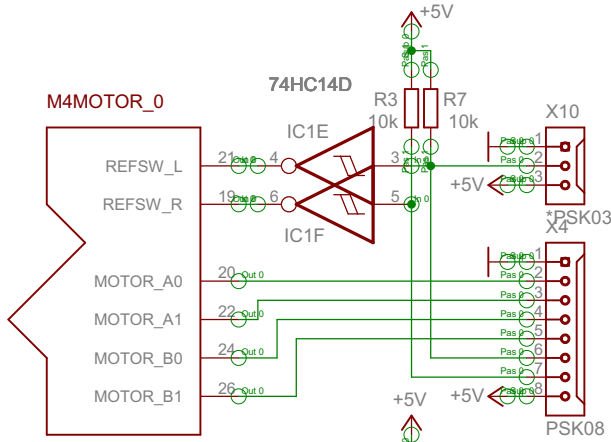

axis1

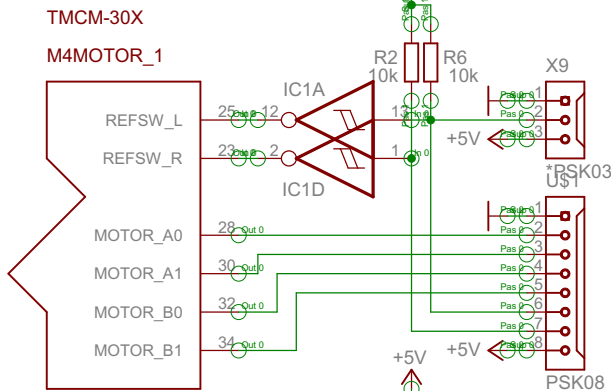

axis2

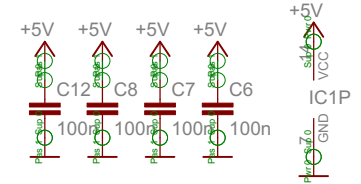
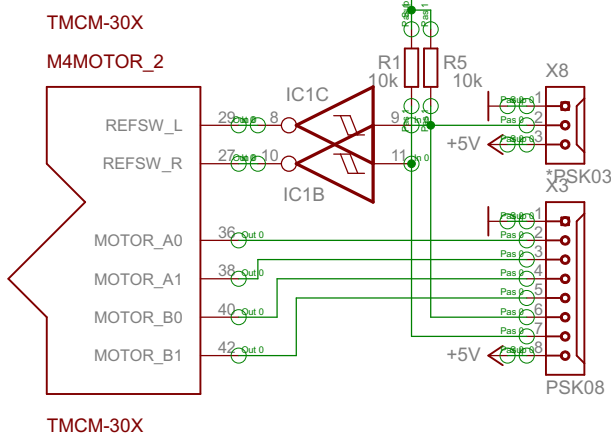

CP_Robot

HAREROD
Marcus Hasenstab
info@harerod.de

TITLE: CP_Robot_12b

Stepper-Driver 1

Document Number:

REU:
V1.1

Date: 15.11.2010 09:09:32

Sheet: 3/12

address 12 / 22

axis6

axis7

axis8

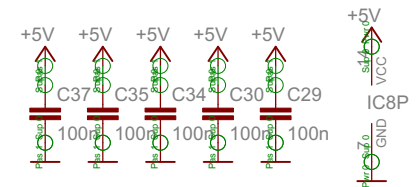
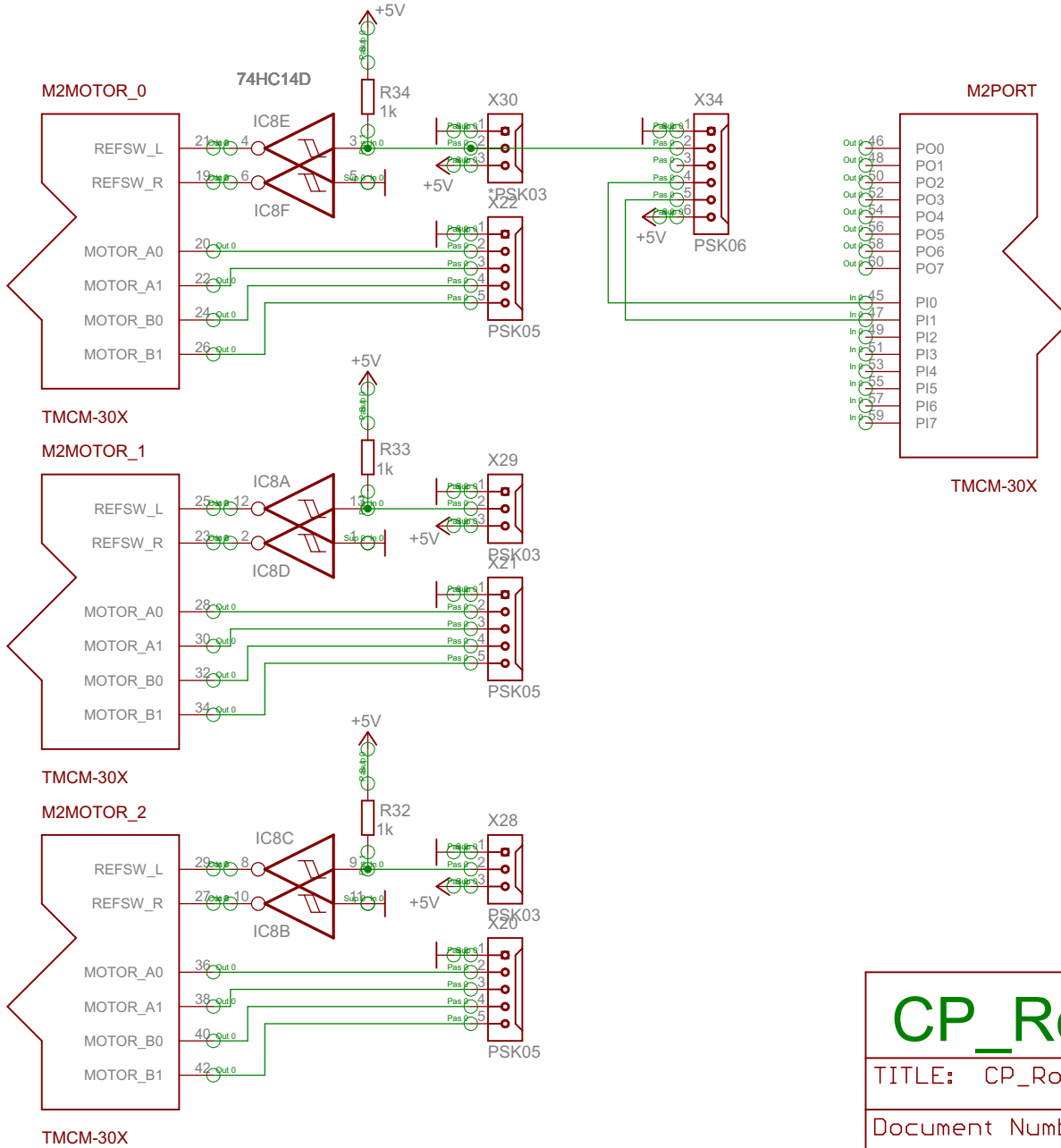

CP_Robot		HAREROD Marcus Hasenstab info@harerod.de	
TITLE: CP_Robot_12b		Stepper-Driver 3	
Document Number:			REV: V1.1
Date: 15.11.2010 09:09:32			Sheet: 5/12

address 13 / 23

axis9

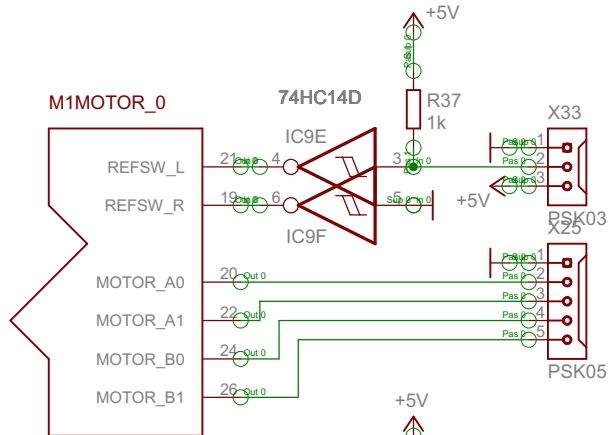

axis10

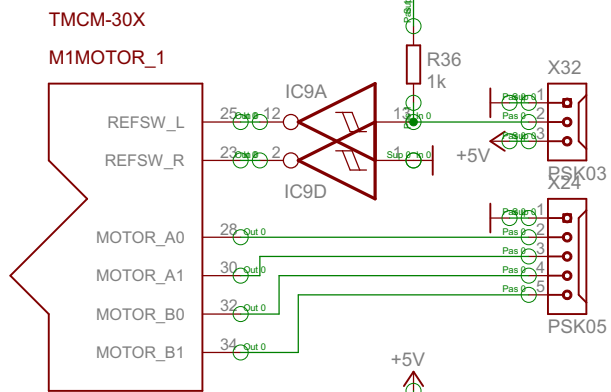

axis12

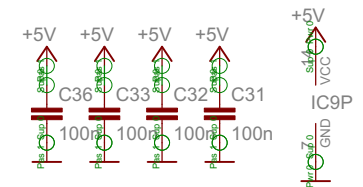
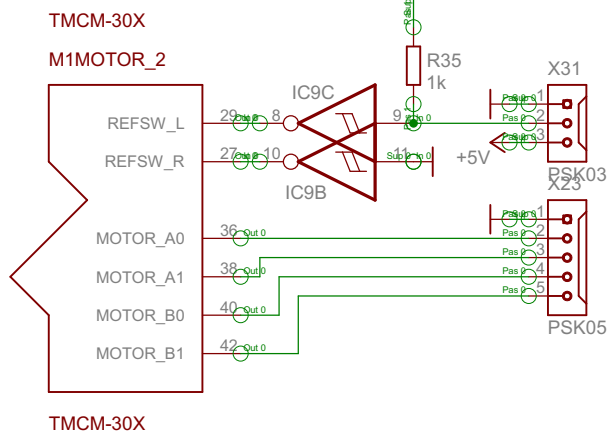

CP_Robot

HAREROD
Marcus Hasenstab
info@harerod.de

TITLE: CP_Robot_12b

Stepper-Driver 4

Document Number:

REV:
V1.1

Date: 15.11.2010 09:09:32

Sheet: 6/12

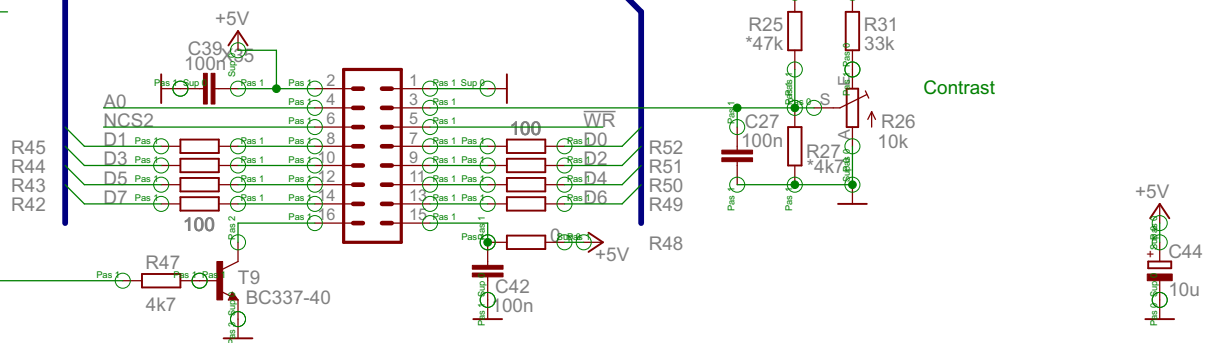
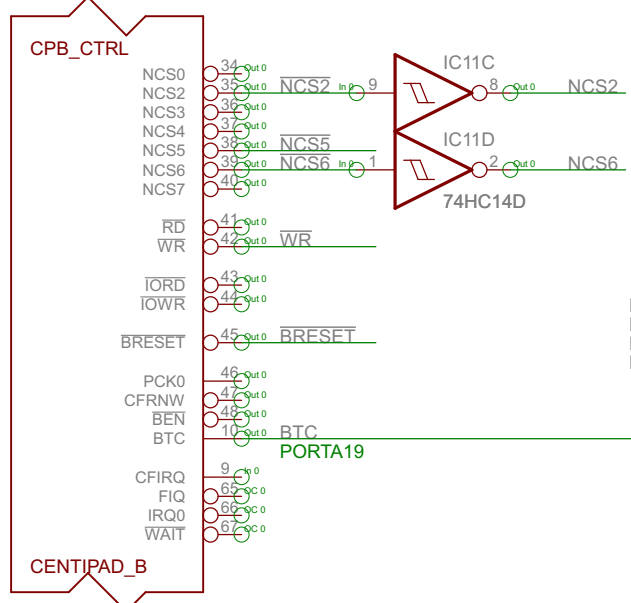
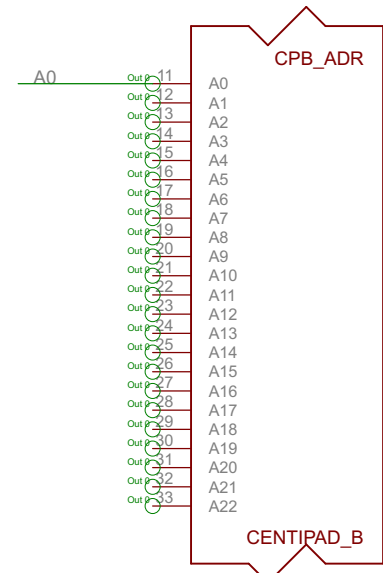
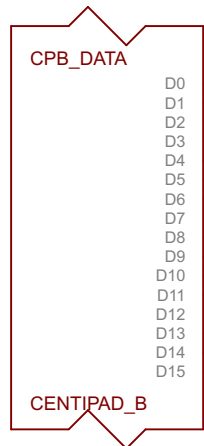

<h1>CP_Robot</h1>		HAREROD Marcus Hasenstab info@harerod.de	
TITLE: CP_Robot_12b		Display	
Document Number:		REU: V1.1	
Date: 15.11.2010 09:09:32		Sheet: 7/12	

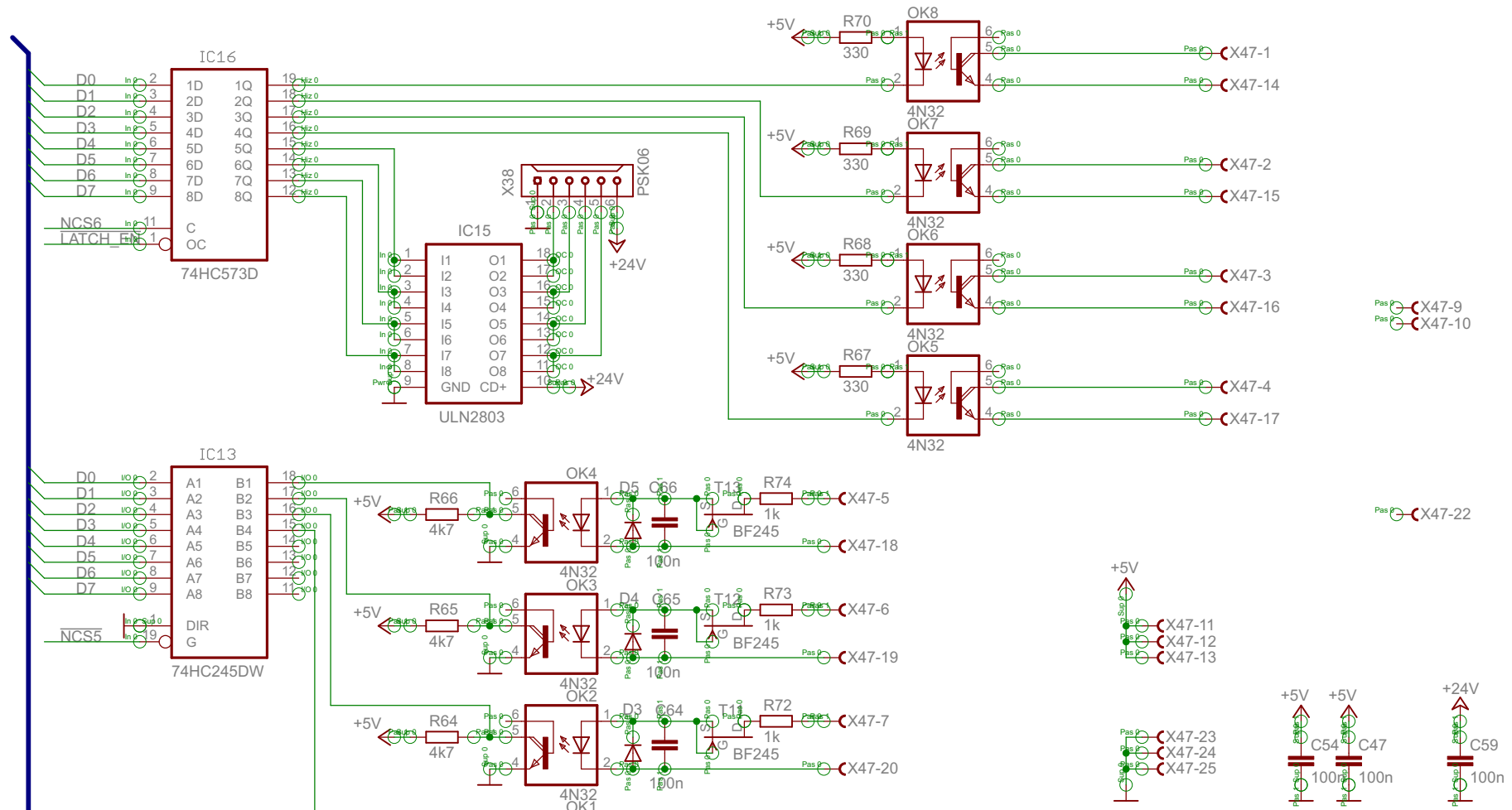

CP_Robot

HAREROD
 Marcus Hasenstab
 info@harerod.de

TITLE: CP_Robot_12b		Opto-Interface	
Document Number:		REV: V1.1	
Date: 15.11.2010 09:09:32		Sheet: 8/12	

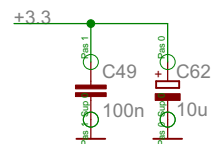
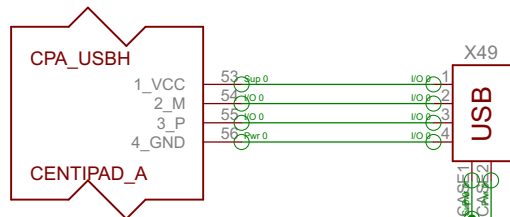
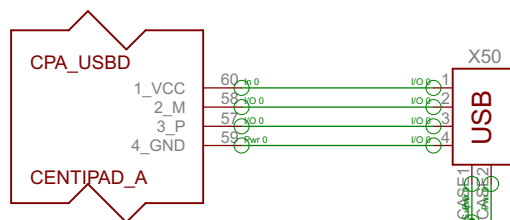
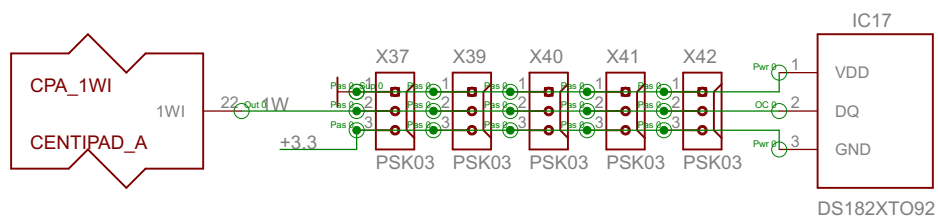
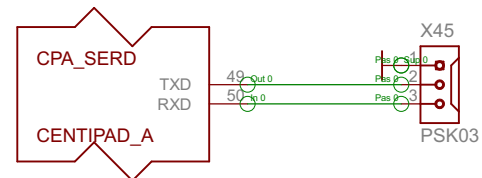
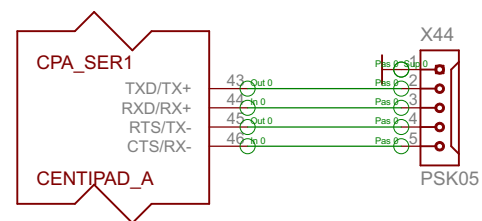
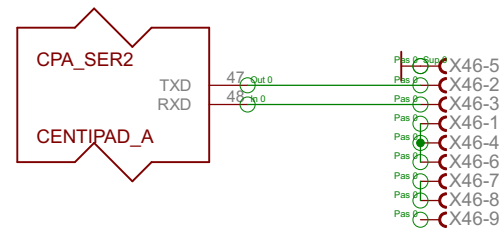
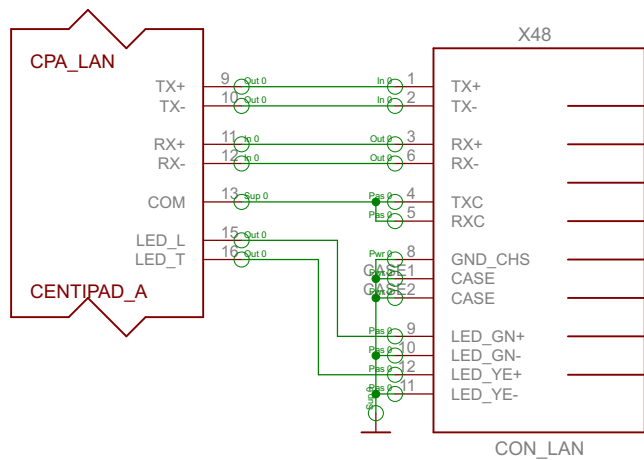

<h1>CP_Robot</h1>		HAREROD Marcus Hasenstab info@harerod.de	
TITLE: CP_Robot_12b		Interface	
Document Number:		REV: V1.1	
Date: 15.11.2010 09:09:32		Sheet: 9/12	

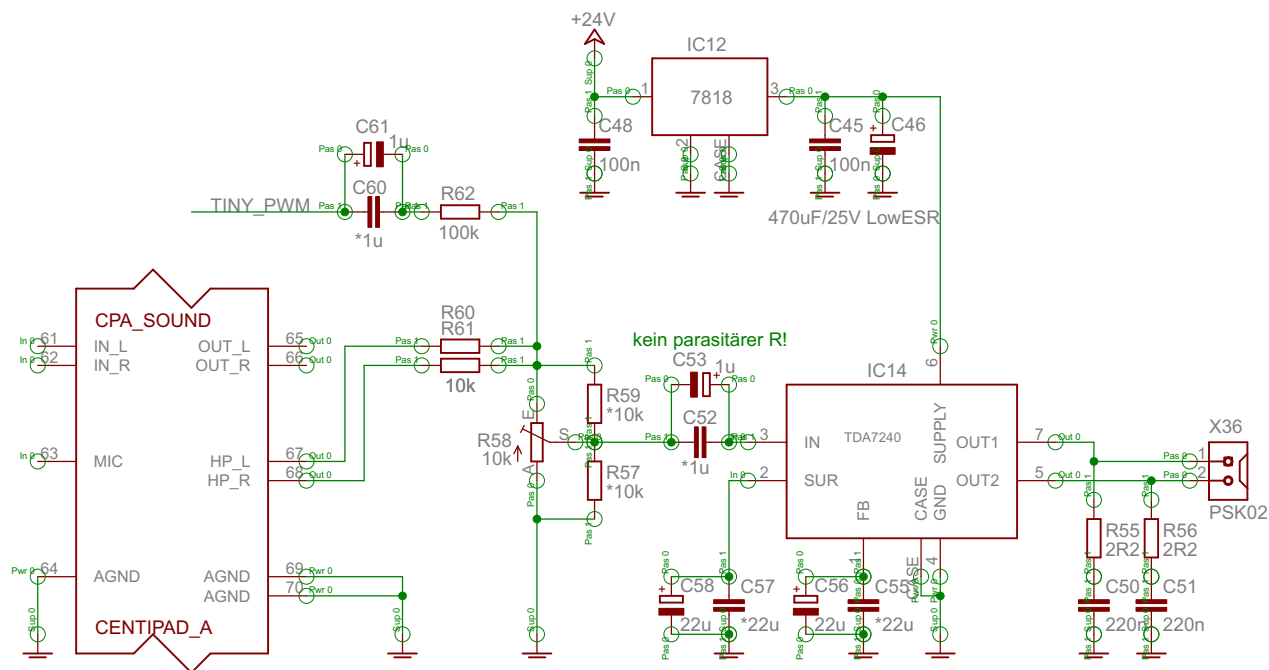

<h1>CP_Robot</h1>		HAREROD Marcus Hasenstab info@harerod.de	
TITLE: CP_Robot_12b		Sound	
Document Number:		REV: V1.1	
Date: 15.11.2010 09:09:32		Sheet: 10/12	

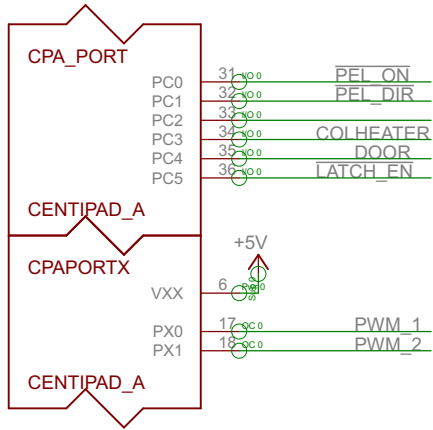

Heater

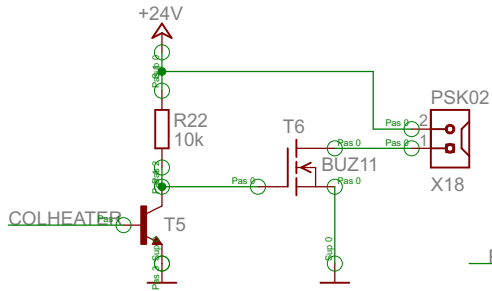

Fan1

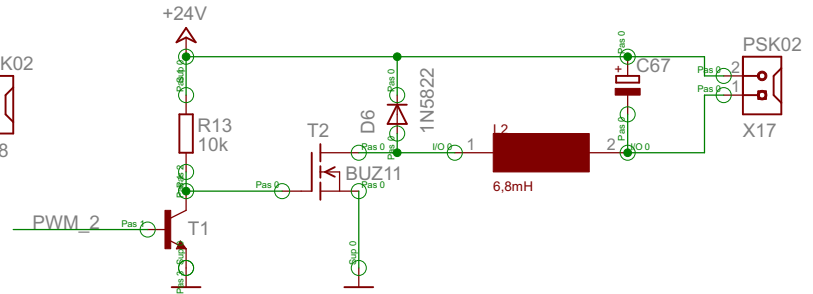

Peltier

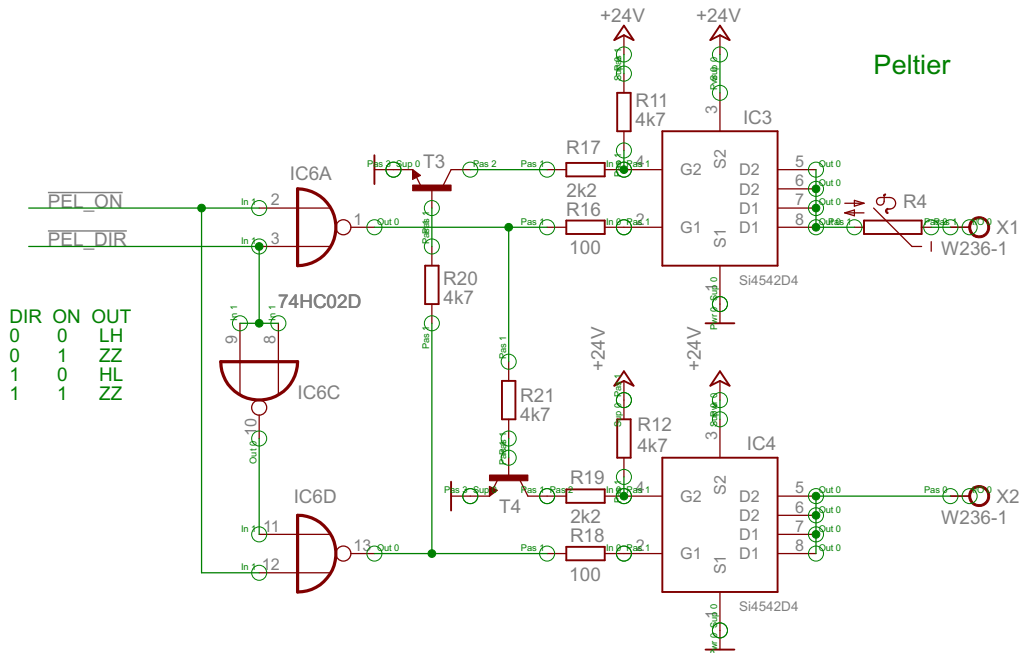

DIR	ON	OUT
0	0	LH
0	1	ZZ
1	0	HL
1	1	ZZ

Door Switch

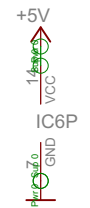
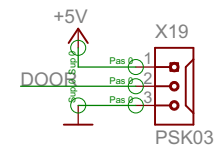

CP_Robot

HAREROD
 Marcus Hasenstab
 info@harerod.de

TITLE: CP_Robot_12b

Switch / PWM

Document Number:

REV:
 V1.1

Date: 15.11.2010 09:09:32

Sheet: 11/12



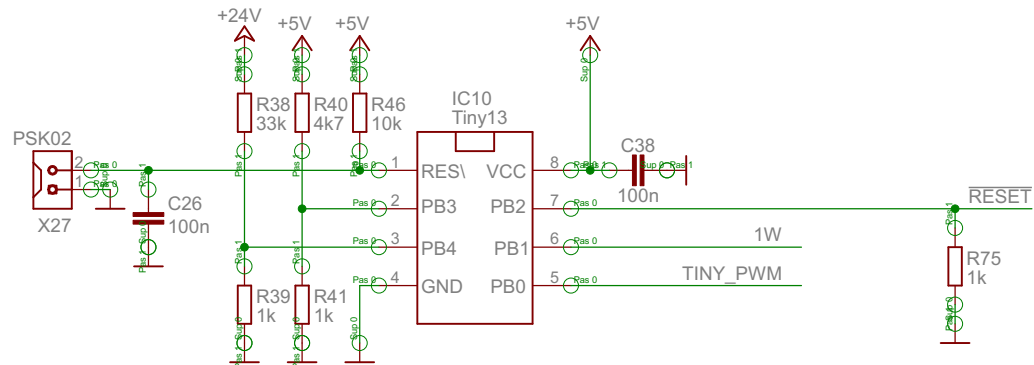

PB3: 0..6,27V
 PB4: 0..37,4V

CP_Robot

HAREROD
 Marcus Hasenstab
 info@harerod.de

TITLE: CP_Robot_12b

Tiny Watchdog

Document Number:

REV:
 V1.1

Date: 15.11.2010 09:09:32

Sheet: 12/12