

KEYBOARD SCANNER FOR
TOUCH SENSITIVE KEYBOARDS

E 510

Features:

- * Fully polyphonic, fast keyboard scanning, up to 128 keys
- * Serial output, according MIDI specifications
- * Resolution of touch sensitivity max. 128 μ sec
- * Speed measured on pressing or releasing key
- * MIDI-channel number selectable
- * HCMOS compatible
- * Key debouncing
- * Integrated oscillator (external quartz)
- * Integrated FIFO
- * Automatic power on detection
- * Only a few external components required
- * 5 V power supply only
- * MIDI (current) or TTL (voltage) output
- * 16 pin DIL case

Pin arrangement:

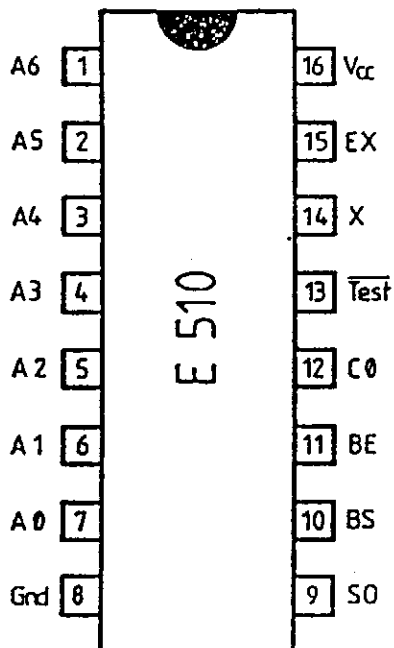

Pin	Function
1	A0
2	A1
3	A2
4	A3
5	A4
6	A5
7	A6
8	Gnd
9	SO : serial output
10	BS : NO input
11	BE : NC input
12	CO : MIDI channel no
13	Test
14	EX : external clock
15	X :
16	Vcc : 5V \pm 5%

key addresses

quartz

Technical data:

Tu : 0...70° C
 Vcc : 5V ±5%

pin	parameter	test conditions	Vcc	min	max	unit
A0...A6	max low level output voltage		5 V		0.4	V
	min high level output voltage	Iout = 4 mA	5 V	4.6		V
C0	max low level input voltage		5 V		1.25	V
	min high level input voltage		5 V	3.75		V
	pull down resistor	Vin = 2.5 V	5 V	10	30	kohm
BE, BS, TEST	max low level input voltage		5 V		1.25	V
	min high level input voltage		5 V	3.75		V
	pull up resistor	Vin = 2.5 V	5 V	10	30	kohm
S0	max low level output voltage	Iout = 5 mA	4.75 V		0.4	V

Power dissipation at 4 Mhz: 5 mA typ

Block diagram:

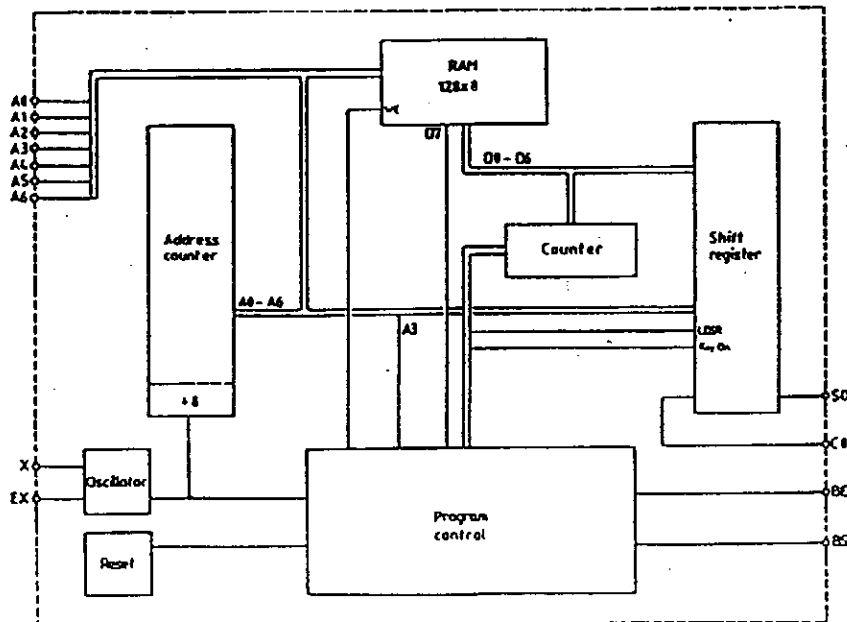

Signal description:

* Key - Interface

Address bus:

The address bus consists of 7 lines A0 ... A6. By means of the address bus of the E 510 the individual key contacts are being addressed. All not used addresses should not pass information. Key numbering is according to MIDI specifications, i.e. key address "0" corresponds to MIDI code "0". If not all address lines are connected the E 510 gives different codes for one key.

Timing-Diagram of the key addresses (A0 ... A6)

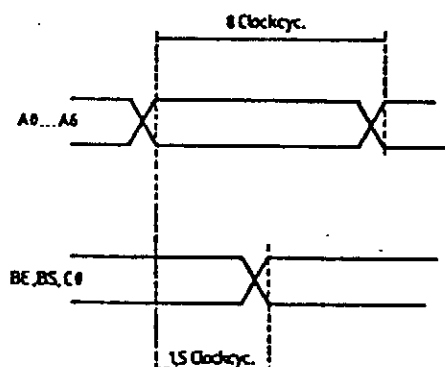

BS (NO input - normal open)

Under normal conditions (all keys are at BE) BS is on "HIGH"-level. As long as the selected key is pressed, BS should go to "LOW"-level, if the address of the pressed key is on. The max. "LOW"-level of the BS is defined with 1.25 V, so that the keys can be decoupled via diodes without additional components. BS should have a pull up resistor of 470 ohm.

BE (NC input - normal close)

Under normal conditions (all keys are at BE) BE will be pulled to "LOW"-level when the key is addressed. If the selected key is not at BE (key pressed), BE input should remain at "HIGH"-level during this time. The max. "LOW"-level of the BE is defined with 1.25 V, so that the key can be decoupled via diodes without additional components. BS should have a pullup resistor of 470 ohm.

* External Interface

SO (serial output)

The serial output can be used as voltage output (TTL-level) or as current output (acc. to MIDI specification).

Voltage output (TTL-level)

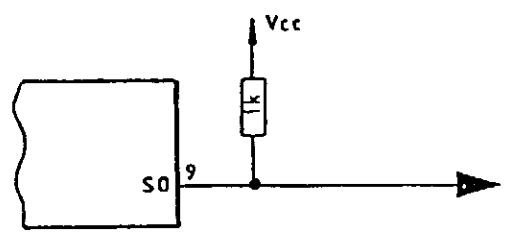

Current output (MIDI spec.)

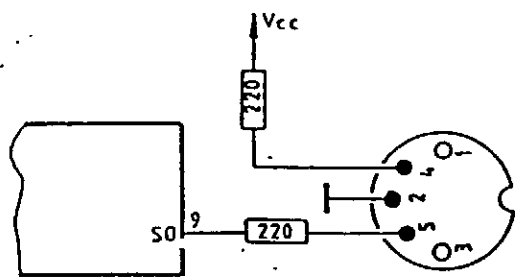

With a clock frequency of 4 MHz the baudrate will be 31250 baud (asynchronous) according to MIDI specification. The data format consists of 1 startbit, 8 data bits (D0 to D7) and 1 stop bit. This results in a period of 320 µsec. per byte for the 10 bits transmitted.

On output SO the key information key on, key off, key no. ,MIDI-channel and velocity, are transmitted as serial signal according to MIDI specifications.

The signal consists of three bytes: one status byte followed by two data bytes. The following tables show the information in the three bytes according to MIDI specifications.

Status byte:

binary code	CO	hex code	note	channel
1 0 0 0	0 0 0 0	\$80	off	1
1 0 0 0	0 0 0 1	\$81	off	2
1 0 0 1	0 0 0 0	\$90	on	1
1 0 0 1	0 0 0 1	\$91	on	2

1st data byte:

binary code	hex code	key no.	
0 0 0 0	0 0 0 0	\$00	key 0
0 0 0 0	0 0 0 1	\$01	key 1
0 0 0 0	0 0 1 0	\$02	key 2
⋮	⋮	⋮	⋮
0 1 1 1	1 1 0 1	\$7D	key 125
0 1 1 1	1 1 1 0	\$7E	key 126
0 1 1 1	1 1 1 1	\$7F	key 127

2nd data byte:

binary code	hex code	time
0 0 0 0 0 0 0 1	\$01	1
0 0 0 0 0 0 1 0	\$02	2
0 0 0 0 0 0 1 1	\$03	3
⋮	⋮	⋮
0 1 1 1 1 1 0 1	\$7D	125
0 1 1 1 1 1 1 0	\$7E	126
0 1 1 1 1 1 1 1	\$7F	127

*) see note

Note: The measured time is calculated in multiples of t_s .

$$t_s = 8 * 128 / f_{quartz}$$

With a typical clock frequency (f_{quartz}) of 4 MHz this results a resolution of: $8 * 128 / 4 \text{ MHz} = 256 \mu\text{sec}$.

The serial output signal looks like this:

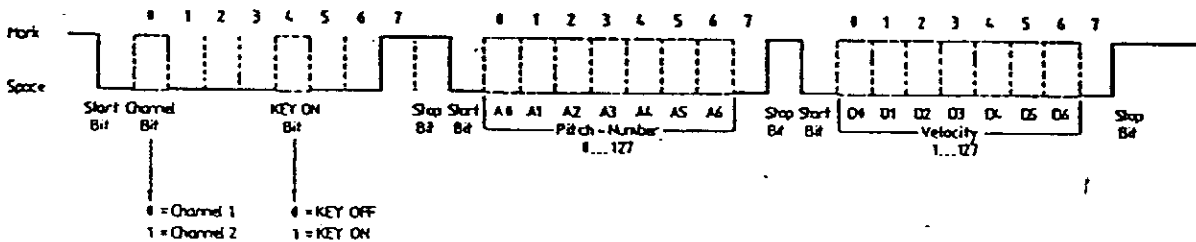

CO (MIDI channel no.)

If the input CO is open or on logical 0, the E 510 transmits data to MIDI channel 1. Is CO logical 1, the data is transmitted on MIDI channel 2 (see status byte; serial output). Input CO is working dynamically, i.e. this bit is checked every scanning cycle. For this reason it is easy to fit out the keyboard with a "split-point". In this case the input CO has to be connected with the corresponding address range that has to be split off (see application example).

EX, X (Clock input for quartz or external oscillator)

These inputs are used to connect the on-chip oscillator to an external parallel-resonant crystal. Alternately, the pin EX may be used as a TTL-level input for external timing. In this case the X input is to be left open.

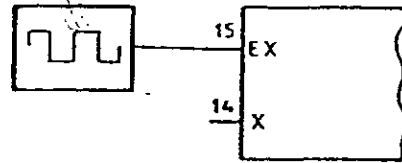
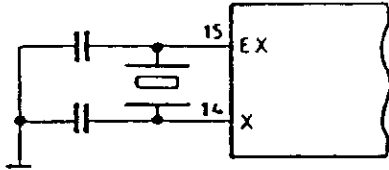

Test (Test input)

The Test input is used for testing purposes only. Internally the input has a pull up resistor. Normally it should be connected with Vcc.

Functional description:

The E 510 scans up to 128 keys (>10 octaves) with a changeover contact. Everytime a key is pressed or released, the velocity is calculated by measuring the time. At the same time every pressing and releasing is tested for validity. The key has only to be recognized if it goes from BE to BS or reverse. In this way is made sure, that contact bouncing does not lead to mis-interpretation.

The time measurement is realized by a 7 bit reverse counting counter. The counter will be disabled as soon as it reaches the value 1, to prevent underflow.

The "LOW"-level on the two inputs BE and BS is defined with 1.25 V in such a way, that all keys can be decoupled via a diode.

An internal FIFO-Register allows fully polyphonic playing, i.e. several keys can be pressed simultaneously.

SO output transmits as a serial signal according to MIDI specification: key on, key off, key number, key channel and velocity. If CO input is left open or logically 0, the data is transmitted on MIDI channel 1; if CO input is logically 1, data is transmitted on MIDI channel 2.

The baudrate of the serial signal is fixed by the oscillator frequency:

4 MHz - 31250 baud (MIDI baudrate)
8 MHz - 62500 baud

Power on reset conditions

After switching on the power supply, the E 510 initiates a power on reset cycle. This takes 1024 clocks. At this time all keys are scanned, but no information is transmitted.

Application example for 8 keys:

This example shows how 8 keys can be connected. For decoding only one HC138 is used; therefore the addressbus has not been decoded completely (A6 is not connected). For this reason the E 150 transmits two different codes for each key, depending on the value of A6 (see table).

A6	A5	A4	A3	A2	A1	A0	key no. (hex)
0	1	0	0	0	0	0	key \$20
0	1	0	0	0	0	1	key \$21
0	1	0	0	0	1	0	key \$22
			⋮				⋮
0	1	0	0	1	1	0	key \$26
0	1	0	0	1	1	1	key \$27

A6	A5	A4	A3	A2	A1	A0	key no. (hex)
1	1	0	0	0	0	0	key \$60
1	1	0	0	0	0	1	key \$61
1	1	0	0	0	1	0	key \$62
			⋮				⋮
1	1	0	0	1	1	0	key \$66
1	1	0	0	1	1	1	key \$67

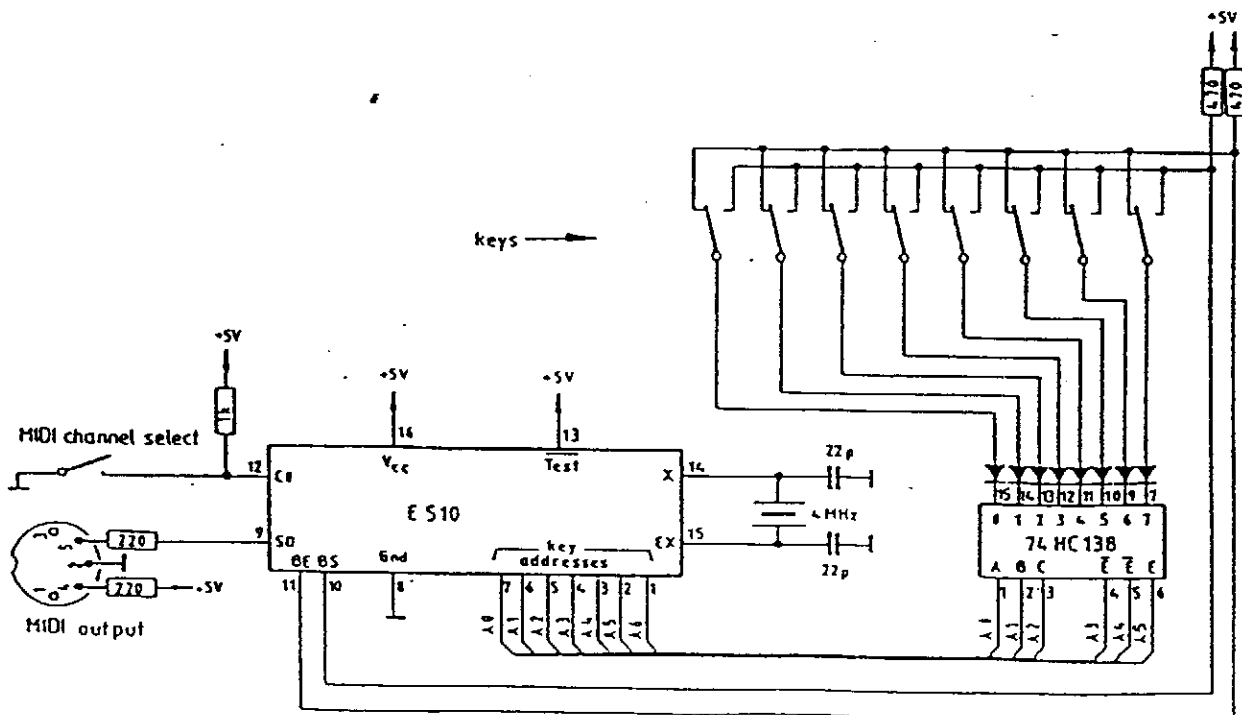

Application example for 128 dynamic keys:

This example shows how the maximum number of dynamic keys can be connected:

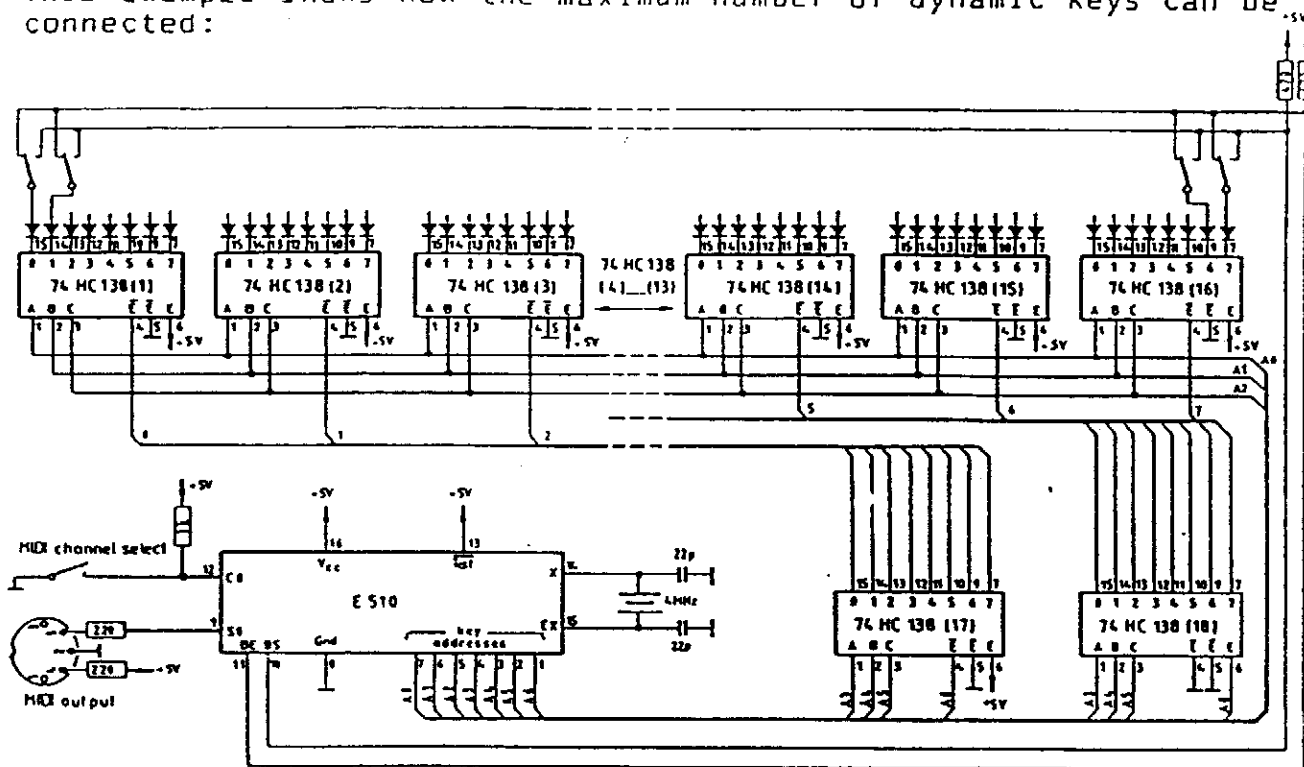

Application example for 128 non-dynamic keys:

When using a keyboard, that has keys with only one NO. contact, you can use the following example. The signal, normally going to BS has to be given inverted to BE as well. The velocity transmitted will be set to maximum (\$7F hex). Key debouncing is now only effected by the clock oscillator, because of the missing change over contact. The debouncing time is: $t = f_{quartz} / 1024$. It may be necessary to lower the quartz frequency, in order to get an optional adjustment to all types of contacts.

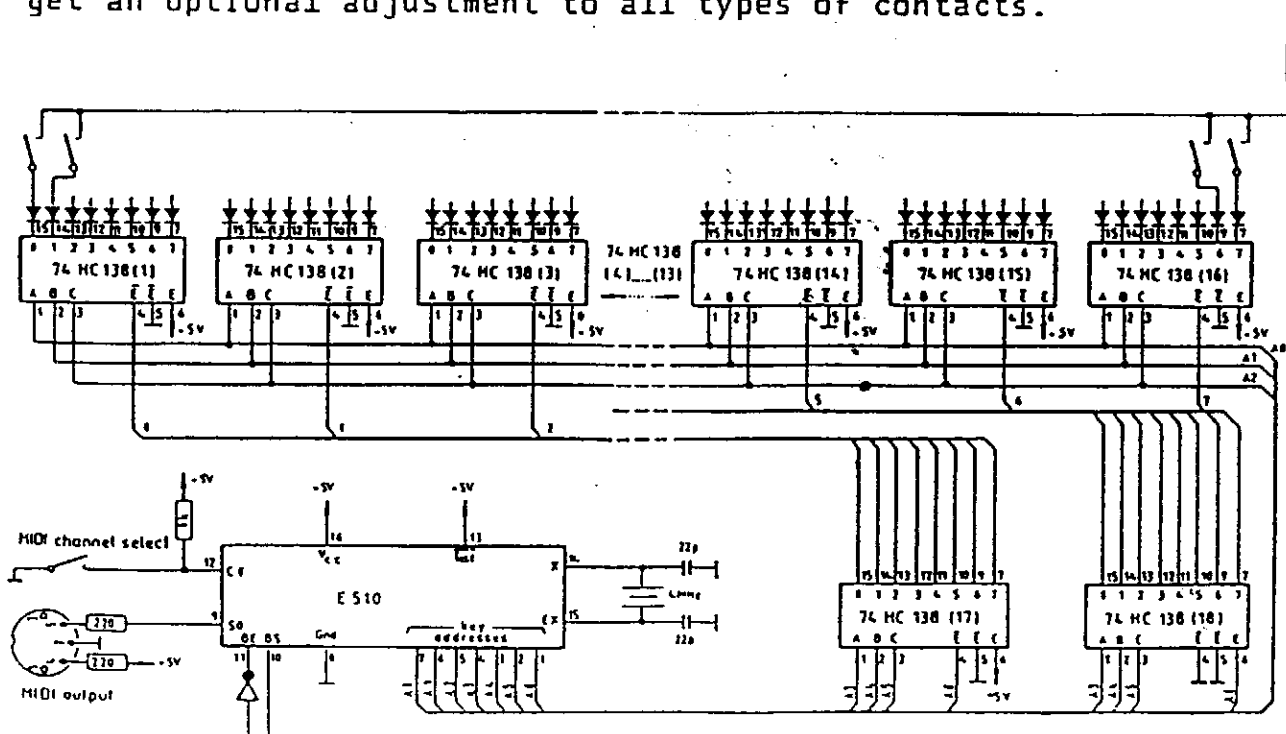

Application example for transposing the keys:

In this case a constant factor n is added to the address output. The E 510 does not transmit the key number of the key pressed, but a key number transposed down by n keys. In the example this is realized by two 4 bit full adders (HC 283). The constant factor n is set up by a 7 bit DIL switch.

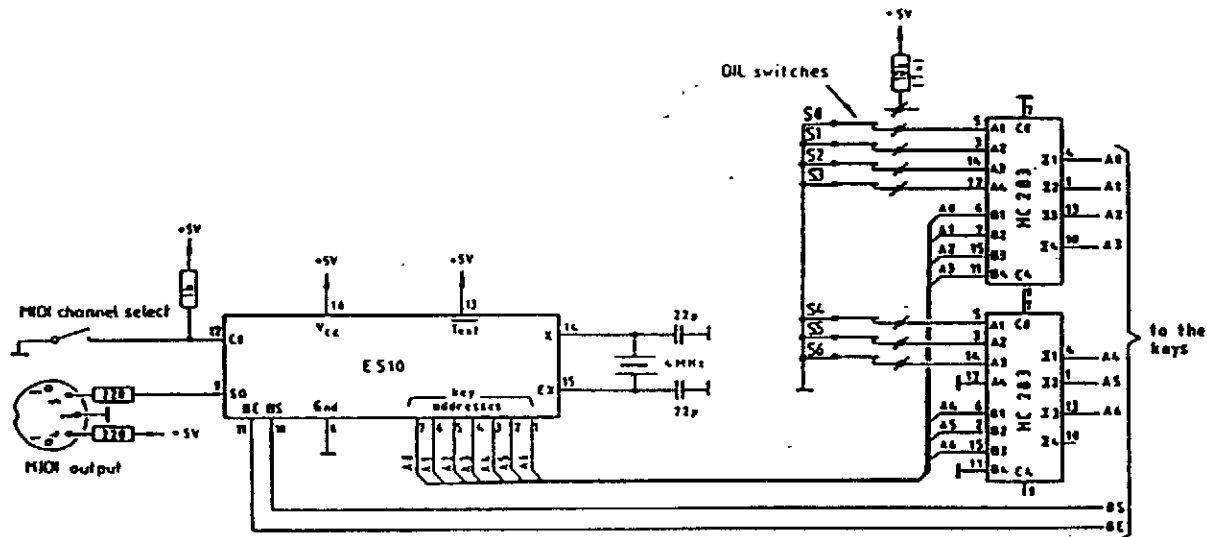

The principles by which this integrated circuit works, described in this data sheet, are protected by patent No. DE 3440289.