

MC35i Siemens Cellular Engine

Version: 01.03
DocID: MC35i_HD_V01.03

Hardware Interface Description

Document Name: **MC35i Hardware Interface Description**

Version: **01.03**

Date: **May 07, 2004**

DocId: **MC35i_HD_V01.03**

Status: **Confidential / Released**

General Notes

Product is deemed accepted by recipient and is provided without interface to recipient's products. The documentation and/or product are provided for testing, evaluation, integration and information purposes. The documentation and/or product are provided on an "as is" basis only and may contain deficiencies or inadequacies. The documentation and/or product are provided without warranty of any kind, express or implied. To the maximum extent permitted by applicable law, Siemens further disclaims all warranties, including without limitation any implied warranties of merchantability, completeness, fitness for a particular purpose and non-infringement of third-party rights. The entire risk arising out of the use or performance of the product and documentation remains with recipient. This product is not intended for use in life support appliances, devices or systems where a malfunction of the product can reasonably be expected to result in personal injury. Applications incorporating the described product must be designed to be in accordance with the technical specifications provided in these guidelines. Failure to comply with any of the required procedures can result in malfunctions or serious discrepancies in results. Furthermore, all safety instructions regarding the use of mobile technical systems, including GSM products, which also apply to cellular phones must be followed. Siemens or its suppliers shall, regardless of any legal theory upon which the claim is based, not be liable for any consequential, incidental, direct, indirect, punitive or other damages whatsoever (including, without limitation, damages for loss of business profits, business interruption, loss of business information or data, or other pecuniary loss) arising out the use of or inability to use the documentation and/or product, even if Siemens has been advised of the possibility of such damages. The foregoing limitations of liability shall not apply in case of mandatory liability, e.g. under the German Product Liability Act, in case of intent, gross negligence, injury of life, body or health, or breach of a condition which goes to the root of the contract. However, claims for damages arising from a breach of a condition, which goes to the root of the contract, shall be limited to the foreseeable damage, which is intrinsic to the contract, unless caused by intent or gross negligence or based on liability for injury of life, body or health. The above provision does not imply a change on the burden of proof to the detriment of the recipient. Subject to change without notice at any time. The interpretation of this general note shall be governed and construed according to German law without reference to any other substantive law.

Copyright

Transmittal, reproduction, dissemination and/or editing of this document as well as utilization of its contents and communication thereof to others without express authorization are prohibited. Offenders will be held liable for payment of damages. All rights created by patent grant or registration of a utility model or design patent are reserved.

Copyright © Siemens AG 2004

Contents

0	Document history	7
1	Introduction	8
1.1	Related documents	8
1.2	Terms and abbreviations.....	9
1.3	Standards	12
1.4	Safety precautions	14
2	Product overview	16
2.1	MC35i key features at a glance.....	17
2.2	Circuit concept	19
3	Application interface	20
3.1	Operating modes	21
3.2	Power supply	22
3.2.1	Power supply pins on the ZIF connector.....	23
3.2.2	Minimizing power losses.....	24
3.3	Power up / down scenarios	25
3.3.1	Turn on MC35i.....	25
3.3.1.1	Turn on GSM engine using the ignition line IGT (Power on).....	25
3.3.1.2	Timing of the ignition process.....	26
3.3.1.3	Turn on GSM engine using the RTC (Alarm mode).....	27
3.3.2	Turn off MC35i.....	28
3.3.2.1	Turn off GSM engine using the AT^SMSO command.....	28
3.3.2.2	Maximum number of turn-on / turn-off cycles	28
3.3.2.3	Emergency shutdown using /EMERGOFF pin.....	29
3.3.3	Automatic shutdown	30
3.3.3.1	Undervoltage shutdown.....	30
3.3.3.2	Temperature dependent shutdown.....	30
3.3.3.3	Deferred shutdown at extreme temperature conditions	31
3.3.3.4	Monitoring the board temperature of MC35i	31
3.3.4	Summary of state transitions (except SLEEP mode).....	32
3.4	Power saving	33
3.4.1	No power saving (AT+CFUN=1).....	33
3.4.2	NON-CYCLIC SLEEP mode (AT+CFUN=0).....	33
3.4.3	CYCLIC SLEEP mode (AT+CFUN=5, 6, 7 and 8).....	34
3.4.4	Timing of the /CTS signal in CYCLIC SLEEP modes	34
3.4.5	Wake up MC35i from SLEEP mode	36
3.5	RTC backup.....	37
3.6	Serial interface.....	38
3.7	Audio interface.....	40
3.7.1	Speech processing.....	41
3.8	SIM interface.....	42
3.8.1	Requirements for using the CCIN pin.....	43
3.8.2	Design considerations for SIM card holder	44
3.9	Control signals.....	45
3.9.1	Inputs	45
3.9.2	Outputs.....	46
3.9.2.1	Synchronization signal.....	46

3.9.2.2	Using the SYNC pin to control a status LED.....	47
3.9.2.3	Behavior of the /RING0 line.....	49
4	RF interface	51
4.1	Antenna connector.....	52
5	Electrical, reliability and radio characteristics	55
5.1	Absolute maximum ratings.....	55
5.2	Operating conditions	55
5.2.1	Temperature conditions.....	55
5.3	Electrical specifications of the application interface.....	56
5.4	Power supply ratings.....	60
5.4.1	Peak current during transmit burst.....	61
5.5	Electrical characteristics of the voiceband part.....	62
5.5.1	Setting audio parameters by AT command.....	62
5.5.2	Audio programming model	63
5.5.3	Characteristics of audio modes	64
5.5.4	Voiceband receive path	65
5.5.5	Voiceband transmit path.....	66
5.6	Air interface.....	67
5.7	Electrostatic discharge	68
5.8	Reliability characteristics	69
6	Mechanics.....	70
6.1	Mechanical dimensions of MC35i.....	70
6.2	Mounting MC35i onto the application platform	72
6.3	ZIF connector (application interface).....	73
6.3.1	FFC	73
6.3.2	Mechanical dimensions of Hirose FH12-40S 0.5 SH connector.....	74
7	Reference approval.....	75
7.1	Reference equipment.....	75
8	APPENDIX: List of parts and recommended accessories.....	76

Figures

Figure 1: Block diagram of MC35i	19
Figure 2: Block diagram of a cellular application	20
Figure 3: Power supply limits during transmit burst	24
Figure 4: Power-on by ignition signal.....	25
Figure 5: Timing of power-on process if VDDL P is not used	26
Figure 6: Timing of power-on process if VDDL P is fed from external source.....	26
Figure 7: Deactivating GSM engine by Power Down signal	29
Figure 8: Timing of /CTS signal (example for a 2.12 s paging cycle).....	35
Figure 9: Beginning of power saving if CFUN=5.....	35
Figure 10: RTC supply from capacitor	37
Figure 11: Serial interface	38
Figure 12: Audio block diagram.....	40
Figure 13: SIM card holder of DSB35 Support Box	44
Figure 14: Pin numbers of Molex SIM card holder on DSB35 Support Box	44
Figure 15: MC35i output control signals	46
Figure 16: LED Circuit (Example).....	48
Figure 17: Incoming voice call	49
Figure 18: Incoming data call	49
Figure 19: URC transmission	49
Figure 20: Antenna connector circuit on MC35i.....	51
Figure 21: Mechanical dimensions of MuRata GSC connector (in mm).....	53
Figure 22: Maximum mechanical stress to the connector.....	54
Figure 23: How to use MuRata tool	54
Figure 24: Pin assignment (top view on MC35i)	56
Figure 25: Peak current (in A) during transmit burst vs. antenna impedance	61
Figure 26: AT audio programming model	63
Figure 27: Structure of audio inputs	66
Figure 28: MC35i – top view	70
Figure 29: Mechanical dimensions of MC35i	71
Figure 30: Recommended screws	72
Figure 31: Hirose FH12 connector	73
Figure 32: Description of Hirose FH12 connector.....	74
Figure 33: Reference equipment for approval	75

Tables

Table 1: MC35i key features.....	17
Table 2: Coding schemes and maximum net data rates over air interface	18
Table 3: Overview of operating modes	21
Table 4: Power supply pins of ZIF connector.....	23
Table 5: AT commands available in Alarm mode	27
Table 6: Temperature dependent behavior	31
Table 7: State transitions of MC35i	32
Table 8: Wake-up events in NON-CYCLIC and CYCLIC SLEEP modes.....	36
Table 9: DCE-DTE wiring	38
Table 10: Signals of the SIM interface (ZIF connector)	42
Table 11: Pin assignment of Molex SIM card holder on DSB35 Support Box	44
Table 12: Input control signals of the MC35i module	45
Table 13: Coding of the status LED.....	47
Table 14: MC35i ring signal.....	50
Table 15: Return loss	51
Table 16: MuRata ordering information	52
Table 17: Ratings and characteristics of the GSC antenna connector.....	52
Table 18: Stress characteristics of the GSC antenna connector	54
Table 19: Absolute maximum ratings	55
Table 20: Operating temperatures.....	55
Table 21: Pin assignment and electrical description of application interface	57
Table 22: Power supply ratings	60
Table 23: Audio parameters adjustable by AT command	62
Table 24: Voiceband characteristics (typical)	64
Table 25: Voiceband receive path	65
Table 26: Voiceband transmit path.....	66
Table 27: Air interface	67
Table 28: Local oscillator and intermediate frequencies used by MC35i.....	67
Table 29: Measured electrostatic values	68
Table 30: Summary of reliability test conditions.....	69
Table 31: Ordering information.....	73
Table 32: Electrical and mechanical characteristics of Hirose FH12-40S 0.5 SH connector.....	73
Table 33: List of accessories.....	76

0 Document history

Preceding document: "MC35i Hardware Interface Description" Version 01.02

New document: "MC35i Hardware Interface Description" Version **01.03**

Chapter	What is new
2.1	Added note regarding options of deferred shutdown at extreme temperature condition
3.3.2.1	More detailed description of turn off procedure, added new URC ^SHUTDOWN
3.3.2.2	Deleted statement on timing of turn-on/turn-off cycles
3.3.3.3	New chapter, describing the enhanced functionality of temperature control
3.4	Revised chapter, described the improved timing of the /CTS signal during CYCLIC SLEEP mode, revised figures and Table 8, added footnote regarding /RTS0 signal.
3.7	Corrected remark on supply circuit for MIC inputs at both analog interfaces.
3.8	Use CCGND line to shield CCIO line from CCCLK line.
3.8.1	Corrected description (added ISO/IEC 7816-3)
3.9.2.2	Modified description of status LED patterns.
3.9.2.3	Recommendations for utilizing /RING0 line
5.1	Modified description of absolute maximum ratings
5.3	Table 21 – /EMERGOFF pin and output pins of serial interface: To keep output pins from floating when in high impedance state use additional resistors.
5.4	Table 22 – Added footnotes regarding maximum current at BATT+ line, antenna performance and average supply current
5.4.1	New Figure 25. Revised text.
5.5.3	Table 24 – Changed EP output signal to 895MV, added footnote on activating the compressor and audio modes 5 and 6

Preceding document: "MC35i Hardware Interface Description" Version 00.02

New document: "MC35i Hardware Interface Description" Version 01.02

Chapter	What is new
2 nd cover page	New version of general notes
1.3	Updated list of standards. Added CE conformity mark and GCF-CC certification.
3.8.1	Corrected description (added ISO/IEC 7816-3)
5.4.1	Revised chapter and modified Figure 25.
5.5.3	Table 24: Gain setting of audio mode changed from 4 (24dB) to 5 (30dB)
5.6	Added values for receiver sensitivity in Table 27. Revised numbers for "RF power @ ARP with 50Ω load". Modified footnote for Table 27.

Preceding document: "MC35i Hardware Interface Description" Version 00.01

New document: "MC35i Hardware Interface Description" Version 00.02

Chapter	What is new
5.4.1	Added Figure 25.
5.5.3	Revised Table 24.

1 Introduction

This document describes the hardware of the Siemens MC35i module that connects to the cellular device application and the air interface. As MC35i is intended to integrate with a wide range of application platforms, all functional components are described fully detailed.

So this guide covers all information you need to design and set up cellular applications incorporating the MC35i module. It helps you to quickly retrieve interface specifications, electrical and mechanical details and information on the requirements to be considered for integrating further components.

1.1 Related documents

- [1] AT Command Set for MC35i, Version 01.03
- [2] MC35i Release Notes, Version 01.03
- [3] GPRS Startup User's Guide
- [4] DSB35 Support Box - Evaluation Kit for Siemens Cellular Engines
- [5] Remote Sat User's Guide
- [6] Multiplexer User's Guide
- [7] Multiplex Driver Developer's Guide for Windows 2000 and Windows XP
- [8] Multiplex Driver Installation Guide for Windows 2000 and Windows XP
- [9] Application Note 14: Audio and Battery Parameter Download
- [10] Application Note 16: Updating MC35i Firmware
- [11] Application Note 24: Application Developers' Guide
- [12] Application Note 02: Audio Interface Design

Prior to using the MC35i engine, be sure to carefully read the latest product information.

To visit the Siemens Website you can use the following link:

<http://www.siemens.com/wm>

1.2 Terms and abbreviations

Abbreviation	Description
ADC	Analog-to-Digital Converter
AGC	Automatic Gain Control
ARP	Antenna Reference Point
ASIC	Application Specific Integrated Circuit
BER	Bit Error Rate
BTS	Base Transceiver Station
CB or CBM	Cell Broadcast Message
CS	Coding Scheme
CSD	Circuit Switched Data
CPU	Central Processing Unit
CE	Conformité Européene (European Conformity)
DAI	Digital Audio Interface
DAC	Digital-to-Analog Converter
dBm0	Digital level, 3.14dBm0 corresponds to full scale, see ITU G.711, A-law
DCE	Data Communication Equipment (typically modems, e.g. Siemens GSM engine)
DCS 1800	Digital Cellular System, also referred to as PCN
DSB	Development Support Box
DSR	Data Set Ready
DTE	Data Terminal Equipment (typically computer, terminal, printer or, for example, GSM application)
DTR	Data Terminal Ready
DTX	Discontinuous Transmission
EFR	Enhanced Full Rate
EGSM	Enhanced GSM
EMC	Electromagnetic Compatibility
ESD	Electrostatic Discharge
ETS	European Telecommunication Standard
FDMA	Frequency Division Multiple Access
FFC	Flat Flexible Cable
FR	Full Rate
GPRS	General Packet Radio Service
GSM	Global Standard for Mobile Communications
HiZ	High Impedance
HR	Half Rate
IC	Integrated Circuit

Abbreviation	Description
IMEI	International Mobile Equipment Identity
I/O	Input/Output
ISO	International Standards Organization
ITU	International Telecommunications Union
kbps	kbits per second
LED	Light Emitting Diode
Mbps	Mbits per second
MMI	Man Machine Interface
MO	Mobile Originated
MS	Mobile Station (GSM engine), also referred to as TE
MT	Mobile Terminated
NTC	Negative Temperature Coefficient
PCB	Printed Circuit Board
PCL	Power Control Level
PCN	Personal Communications Network, also referred to as DCS 1800
PCS	Personal Communication System
PD	Power Down
PDU	Protocol Data Unit
PPP	Point-to-point protocol
PSU	Power Supply Unit
R&TTE	Radio and Telecommunication Terminal Equipment
RAM	Random Access Memory
RF	Radio Frequency
ROM	Read-only Memory
RMS	Root Mean Square (value)
RTC	Real Time Clock
Rx	Receive Direction
SAR	Specific Absorption Rate
SELV	Safety Extra Low Voltage
SIM	Subscriber Identification Module
SMS	Short Message Service
SRAM	Static Random Access Memory
TA	Terminal adapter (e.g. GSM engine)
TDMA	Time Division Multiple Access
TE	Terminal Equipment, also referred to as DTE
Tx	Transmit Direction
UART	Universal asynchronous receiver-transmitter

Abbreviation	Description
URC	Unsolicited Result Code
USSD	Unstructured Supplementary Service Data
VSWR	Voltage Standing Wave Ratio
ZIF	Zero Insertion Force
<i>Phonebook abbreviations</i>	
FD	SIM fixdialing phonebook
LD	Last dialing phonebook (list of numbers most recently dialed)
MC	Mobile Equipment list of unanswered MT calls (missed calls)
ME	Mobile Equipment phonebook
ON	Own numbers (MSISDNs)
RC	Mobile Equipment list of received calls
SM	SIM phonebook

1.3 Standards

MC35i has been approved to comply with the directives and standards listed below and is labeled with the CE conformity mark.

Directives

99/05/EC	Directive of the European Parliament and of the council of 9 March 1999 on radio equipment and telecommunications terminal equipment and the mutual recognition of their conformity, in short referred to as R&TTE Directive 1999/5/EC The product is labeled with the CE conformity mark CE 0682
89/336/EC	Directive on electromagnetic compatibility
73/23/EC	Directive on electrical equipment designed for use within certain voltage limits (Low Voltage Directive)

Standards of type approval

3GPP TS 51.010-1	“Digital cellular telecommunications system (Phase 2); Mobile Station (MS) conformance specification”
ETSI EN 301 511	V7.0.1 (2000-12) Candidate Harmonized European Standard (Telecommunications series) Global System for Mobile communications (GSM); Harmonized standard for mobile stations in the GSM 900 and DCS 1800 bands covering essential requirements under article 3.2 of the R&TTE directive (1999/5/EC) (GSM 13.11 version 7.0.1 Release 1998)
GCF-CC	“Global Certification Forum - Certification Criteria”
ETSI EN 301 489-7	V1.1.1 (2000-09) Candidate Harmonized European Standard (Telecommunications series) Electro Magnetic Compatibility and Radio spectrum Matters (ERM); Electro Magnetic Compatibility (EMC) standard for radio equipment and services; Part 7: Specific conditions for mobile and portable radio and ancillary equipment of digital cellular radio telecommunications systems (GSM and DCS)
EN 60 950	Safety of information technology equipment (2000)

Requirements of quality

IEC 60068	Environmental testing
DIN EN 60529	IP codes

SAR requirements specific to handheld mobiles

Mobile phones, PDAs or other handheld transmitters and receivers incorporating a GSM module must be in accordance with the guidelines for human exposure to radio frequency energy. This requires the Specific Absorption Rate (SAR) of handheld MC35i based applications to be evaluated and approved for compliance with national and/or international regulations.

Since the SAR value varies significantly with the individual product design manufacturers are advised to submit their product for approval if designed for handheld operation. For European and US markets the relevant directives are mentioned below. It is the responsibility of the manufacturer of the final product to verify whether or not further standards, recommendations of directives are in force outside these areas.

Products intended for sale on US markets

ES 59005/ANSI C95.1 Considerations for evaluation of human exposure to Electromagnetic Fields (EMFs) from Mobile Telecommunication Equipment (MTE) in the frequency range 30MHz-6GHz

Products intended for sale on European markets

EN 50360 Product standard to demonstrate the compliance of mobile phones with the basic restrictions related to human exposure to electromagnetic fields (300 MHz - 3 GHz)

1.4 Safety precautions

The following safety precautions must be observed during all phases of the operation, usage, service or repair of any cellular terminal or mobile incorporating MC35i. Manufacturers of the cellular terminal are advised to convey the following safety information to users and operating personnel and to incorporate these guidelines into all manuals supplied with the product. Failure to comply with these precautions violates safety standards of design, manufacture and intended use of the product. Siemens AG assumes no liability for customer failure to comply with these precautions.



When in a hospital or other health care facility, observe the restrictions on the use of mobiles. Switch the cellular terminal or mobile off, if instructed to do so by the guidelines posted in sensitive areas. Medical equipment may be sensitive to RF energy.

The operation of cardiac pacemakers, other implanted medical equipment and hearing aids can be affected by interference from cellular terminals or mobiles placed close to the device. If in doubt about potential danger, contact the physician or the manufacturer of the device to verify that the equipment is properly shielded. Pacemaker patients are advised to keep their hand-held mobile away from the pacemaker, while it is on.



Switch off the cellular terminal or mobile before boarding an aircraft. Make sure it cannot be switched on inadvertently. The operation of wireless appliances in an aircraft is forbidden to prevent interference with communications systems. Failure to observe these instructions may lead to the suspension or denial of cellular services to the offender, legal action, or both.



Do not operate the cellular terminal or mobile in the presence of flammable gases or fumes. Switch off the cellular terminal when you are near petrol stations, fuel depots, chemical plants or where blasting operations are in progress. Operation of any electrical equipment in potentially explosive atmospheres can constitute a safety hazard.



Your cellular terminal or mobile receives and transmits radio frequency energy while switched on. Remember that interference can occur if it is used close to TV sets, radios, computers or inadequately shielded equipment. Follow any special regulations and always switch off the cellular terminal or mobile wherever forbidden, or when you suspect that it may cause interference or danger.



Road safety comes first! Do not use a hand-held cellular terminal or mobile when driving a vehicle, unless it is securely mounted in a holder for handsfree operation. Before making a call with a hand-held terminal or mobile, park the vehicle.

Handsfree devices must be installed by qualified personnel. Faulty installation or operation can constitute a safety hazard.



IMPORTANT!

Cellular terminals or mobiles operate using radio signals and cellular networks cannot be guaranteed to connect in all conditions. Therefore, you should never rely solely upon any wireless device for essential communications, for example emergency calls.

Remember, in order to make or receive calls, the cellular terminal or mobile must be switched on and in a service area with adequate cellular signal strength.

Some networks do not allow for emergency calls if certain network services or phone features are in use (e.g. lock functions, fixed dialing etc.). You may need to deactivate those features before you can make an emergency call.

Some networks require that a valid SIM card be properly inserted in the cellular terminal or mobile.

2 Product overview

Designed for operation on GSM 900 MHz and GSM 1800 MHz networks, MC35i supports GPRS multislots class 8 (1 Tx, up to 4 Rx timeslots) and the GPRS coding schemes CS-1, CS-2, CS-3 and CS-4.

To save space on the application platform, MC35i comes as an extremely slim and compact module. This makes it ideally suited for a broad range of mobile computing devices, such as laptops, notebooks, multimedia appliances, and particularly offers easy integration with PDAs, pocket organizers or miniature mobile phones.

The tiny MC35i module incorporates all you need to create high-performance GSM/GPRS solutions: baseband processor, power supply ASIC, complete radio frequency circuit including a power amplifier and antenna interface. The power amplifier is directly fed from the supply voltage BATT+. The MC35i software is residing in a flash memory device. An additional SRAM enables MC35i to meet the demanding requirements of GPRS connectivity.

The physical interface to the cellular application is made through a ZIF connector. It consists of 40 pins, required for controlling the unit, transferring data and audio signals and providing power supply lines.

The serial interface offers easy integration with the Man-Machine Interface (MMI), remote control by AT commands and supports baud rates up to 230 kbps.

2.1 MC35i key features at a glance

Table 1: MC35i key features

Feature	Implementation
Power supply (typical)	Single supply voltage 3.3V – 4.8V
Power saving	Current power consumption while remaining in SLEEP mode: 3mA
GSM class	Small MS
Frequency bands	<ul style="list-style-type: none"> Dual Band EGSM 900 and GSM 1800 Compliant to GSM Phase 2/2+
Transmit power	<ul style="list-style-type: none"> Class 4 (2W) at EGSM 900 Class 1 (1W) at GSM 1800
GPRS connectivity	<ul style="list-style-type: none"> GPRS multi-slot class 8 GPRS mobile station class B
DATA	<p><i>GPRS:</i></p> <ul style="list-style-type: none"> GPRS data downlink transfer: max. 85.6 kbps (see Table 2) GPRS data uplink transfer: max. 21.4 kbps (see Table 2) Coding scheme: CS-1, CS-2, CS-3 and CS-4 MC35i supports the two protocols PAP (Password Authentication Protocol) and CHAP (Challenge Handshake Authentication Protocol) commonly used for PPP connections. Support of Packet Switched Broadcast Control Channel (PBCCH) allows you to benefit from enhanced GPRS performance when offered by the network operators. <p><i>CSD:</i></p> <ul style="list-style-type: none"> CSD transmission rates: 2.4, 4.8, 9.6, 14.4 kbps, non-transparent, V.110 Unstructured Supplementary Services Data (USSD) support
SMS	<ul style="list-style-type: none"> MT, MO, CB, Text and PDU mode SMS storage: SIM card plus 25 SMS locations in the mobile equipment Transmission of SMS alternatively over CSD or GPRS. Preferred mode can be user-defined.
FAX	Group 3: Class 1, Class 2
SIM interface	<ul style="list-style-type: none"> Supported SIM card: 3V External SIM card reader has to be connected via interface connector (note that card reader is not part of MC35i)
Antenna interface	50Ω antenna connector
Audio interface	Two analog audio interfaces (balanced microphone inputs and balanced outputs)
Speech codec	<p>Triple rate codec:</p> <ul style="list-style-type: none"> Half Rate (ETS 06.20) Full Rate (ETS 06.10) Enhanced Full Rate (ETS 06.50 / 06.60 / 06.80) Enhanced handsfree operation with echo cancellation and noise reduction
Serial interface	<ul style="list-style-type: none"> 2.65V level bi-directional bus for commands / data using AT commands Supports RTS/CTS hardware handshake and software XON/XOFF flow control. Multiplex ability according to GSM 07.10 Multiplexer protocol

Feature	Implementation
	<ul style="list-style-type: none"> Baud rates from 300bps to 230.400 bps Autobauding supports baud rates: 1200, 2400, 4800, 9600, 19200, 38400, 57600, 115200 and 230400 bps
Phonebook management	Supported phonebook types: SM, FD, LD, MC, RC, ON, ME
SIM Application Toolkit	Supports SAT class 3, GSM 11.14 Release 98, support of letter class "c"
Ringing tones	Offers a choice of 7 different ringing tones / melodies, easily selectable with AT commands
Real time clock	Implemented
Timer function	Programmable via AT command
Environmental	Temperature: <ul style="list-style-type: none"> Normal operation: -20°C to +55°C Restricted operation: -25°C to -20°C and +55°C to +70°C Auto switch-off: >+70°C and <-25°C When an emergency call or a call to a predefined phone number is in progress automatic temperature shutdown is deferred. Humidity: <ul style="list-style-type: none"> max. 90 % relative humidity
Physical characteristics	Size: 54.5± 0.2. x 36.0± 0.2 x 3.55± 0.3mm Weight: 9g
Evaluation kit	The DSB35 Support Box is an evaluation kit designed to test and type approve Siemens cellular engines and provide a sample configuration for application engineering. For ordering information see Chapter 8.

Table 2: Coding schemes and maximum net data rates over air interface

Coding scheme	1 Timeslot	2 Timeslots	4 Timeslots
CS-1:	9.05 kbps	18.1 kbps	36.2 kbps
CS-2:	13.4 kbps	26.8 kbps	53.6 kbps
CS-3:	15.6 kbps	31.2 kbps	62.4 kbps
CS-4:	21.4 kbps	42.8 kbps	85.6 kbps

Please note that the values stated above are maximum ratings which, in practice, are influenced by a great variety of factors, primarily, for example, traffic variations and network coverage.

2.2 Circuit concept

Figure 1 shows a block diagram of the MC35i module and illustrates the major functional components:

GSM Baseband Block:

- GSM Controller operating at 26MHz
- Power supply ASIC
- DSP operating at 78MHz
- Memory
- SRAM
- Application interface (ZIF connector)

GSM RF section:

- RT transceiver
- RF power amplifier
- RF frontend
- Antenna connector

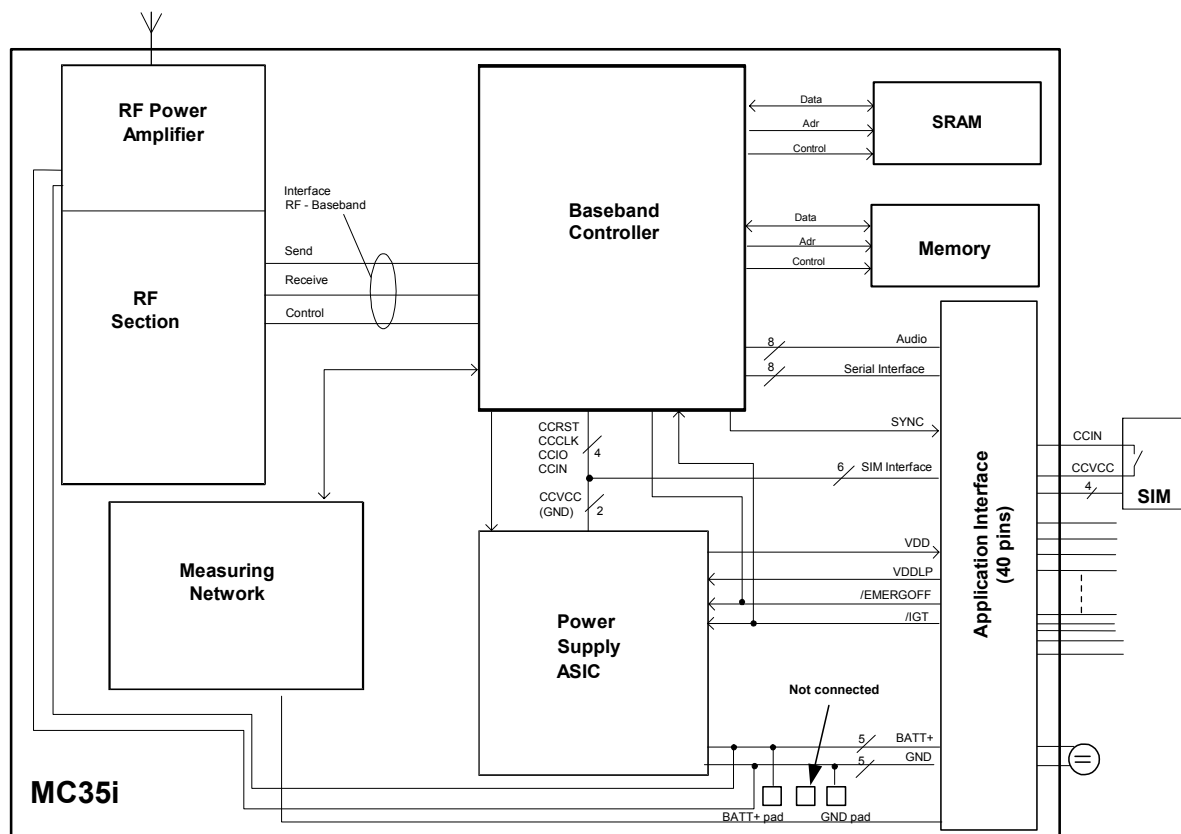

Figure 1: Block diagram of MC35i

3 Application interface

MC35i is equipped with a 40-pin 0.5mm pitch ZIF connector that connects to the cellular application platform. The host interface incorporates several sub-interfaces described in the following chapters:

- Power supply (see Chapter 3.2)
- Serial interface (see Chapter 3.6)
- Two audio interfaces (see Chapter 3.7)
- SIM interface (see Chapter 3.8)

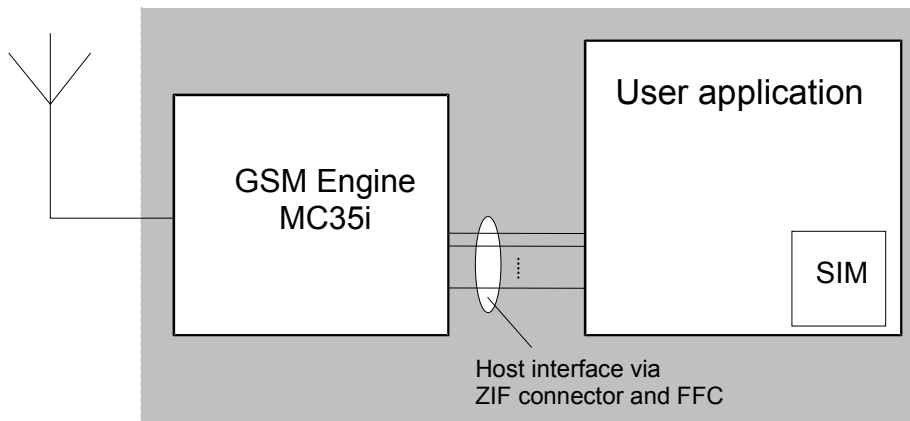

Figure 2: Block diagram of a cellular application

Electrical and mechanical characteristics of the ZIF connector are specified in Chapter 5.3. Ordering information for the ZIF connector and the required cables are listed in Chapter 8.

3.1 Operating modes

The table below briefly summarizes the various operating modes referred to in the following chapters.

Table 3: Overview of operating modes

Mode	Function
Normal operation	GSM / GPRS SLEEP Various powersave modes set with AT+CFUN command. Software is active to minimum extent. If the module was registered to the GSM network in IDLE mode, it remains, in SLEEP mode, registered and pageable from the BTS. Power saving can be chosen at different levels: The NON-CYCLIC SLEEP mode (AT+CFUN=0) disables the AT interface. The CYCLIC SLEEP modes AT+CFUN=5, 6, 7 and 8 alternately activate and deactivate the AT interfaces to allow permanent access to all AT commands.
	GSM IDLE Software is active. Once registered to the GSM network, the module can be paged from the BTS and is ready to send and receive.
	GSM TALK Connection between two subscribers is in progress. Power consumption depends on network coverage individual settings, such as DTX off/on, FR/EFR/HR, hopping sequences, antenna.
	GPRS IDLE Module is ready for GPRS data transfer, but no data is currently sent or received. Power consumption depends on network settings and GPRS configuration (e.g. DRX settings)
	GPRS DATA GPRS data transfer in progress. Power consumption depends on network settings (e.g. power control level), uplink / downlink data rates and GPRS configuration (e.g. used multislots settings).
Power Down	Normal shutdown after sending AT^SMSO command or emergency power off via /EMERGOFF pin. The Power Supply ASIC (PSU_ASIC) disconnects the supply voltage from the baseband part of the circuit. Only a voltage regulator in the PSU-ASIC is active for powering the RTC. Software is not active. The serial interface is not accessible. Operating voltage (connected to BATT+) remains applied
Alarm mode	Restricted operation launched by RTC alert function while the module is in Power Down mode. In Alarm mode, the module remains deregistered from the GSM network. Limited number of AT commands are accessible.

See also Table 8 and Table 7 for the various options of waking up the GSM engine and proceeding from one mode to another.

3.2 Power supply

The power supply of MC35i has to be a single voltage source in the range of $V_{\text{BATT+}} = 3.3\text{V} \dots 4.8\text{V}$. It must be able to withstand a sufficient current in a transmission burst which typically rises to 2A (see Chapter 5.4.1). Beyond that, the power supply must be able to account for increased current consumption if the module is exposed to inappropriate conditions, for example antenna mismatch.

5 BATT+ pins and 5 GND pins are available on the ZIF connector. The RF power amplifier is driven directly from BATT+.

All the key functions for supplying power to the GSM engine are handled by an ASIC power supply. The ASIC provides the following features:

- Stabilizes the supply voltages for the GSM baseband processor and for the RF part using linear voltage regulators.
- Controls the module's power up and power down procedures.
- A watchdog logic implemented in the baseband processor periodically sends signals to the ASIC, allowing it to maintain the supply voltage for all MC35i components. Whenever the watchdog pulses fail to arrive constantly, the module is turned off.
- Delivers a regulated voltage of 2.9V across the VDD pin. The output voltage VDD may be used to supply your application, for example, an external LED or level shifter. However, the external circuitry must not cause any spikes or glitches on voltage VDD. This voltage is not available in POWER DOWN mode. Therefore, the VDD pin can be used to indicate whether or not MC35i is in POWER DOWN mode.
- Provides power to the SIM interface.

Please refer to Table 4 for a description of the power supply pins and their electrical specifications.

3.2.1 Power supply pins on the ZIF connector

10 pins of the ZIF connector are dedicated to connect the supply voltage (BATT+) and ground (GND). The values stated below must be measured directly at the reference points on the MC35i board (reference point BATT+ pad and reference point GND pad as shown in Figure 29)

VDDL P can be used to back up the RTC.

Table 4: Power supply pins of ZIF connector

Signal name	Pin	I/O	Description	Parameter
BATT+	1-5	I/O	Positive operating voltage	3.3 V...4.8 V, $I_{tvd} \leq 2$ A during transmit burst (see Chapter 5.4.1) The minimum operating voltage must not fall below 3.3 V, not even in case of voltage drop.
GND	6-10	X	Ground	0 V
VDDL P	30	I/O	Buffering of RTC (see Chapter 3.3.1.3)	$U_{OUT,max} = V_{BATT+}$ $U_{IN} = 2.0$ V...5.5 V $R_i = 1$ k Ω $I_{in,max} = 30$ μ A

3.2.2 Minimizing power losses

When designing the power supply for your application please pay specific attention to power losses. Ensure that the input voltage measured on the MC35i never drops below the specified minimum (3.3V at BATT+), not even in a transmit burst where current consumption can rise to typical peaks of 2A at BATT+. It should be noted that MC35i switches off when exceeding these limits. Any voltage drops that may occur in a transmit burst should not exceed 400mV. For further details see Chapter 5.4.

Note: In order to minimize power losses, use an FFC cable as short as possible. The resistance of the power supply lines on the host board should also be considered.

Example: The ZIF-FFC-ZIF connection causes a resistance of 50mΩ in the BATT+ line and 50mΩ in the GND line, if the FFC reaches the maximum length of 200mm. As a result, a 2A transmit burst would add up to a total voltage drop of 200mV.

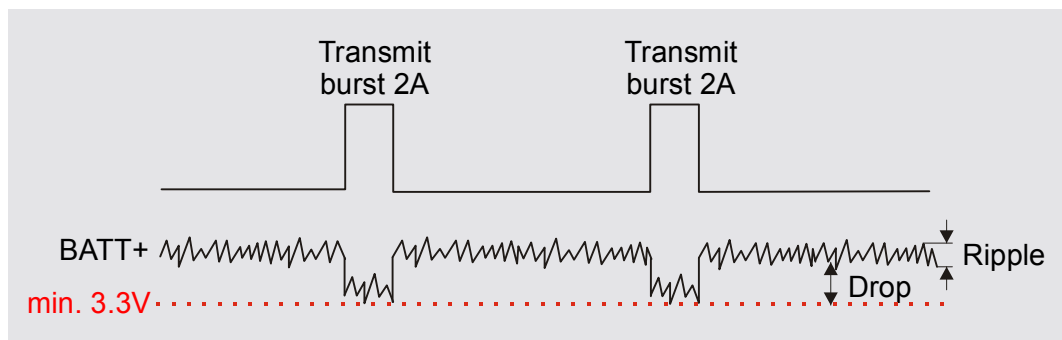

Figure 3: Power supply limits during transmit burst

The input voltage $V_{\text{BATT+}}$ must be measured directly at the reference points on the MC35i board. For detailed information see Figure 29.

3.3 Power up / down scenarios

3.3.1 Turn on MC35i

Your MC35i GSM / GPRS engine can be activated in a variety of ways which are described in the following chapters:

- via ignition line /IGT: starts normal operating state (see Chapters 3.3.1.1 and 3.3.1.2)
- via RTC interrupt: starts Alarm mode (see Chapter 3.3.1.3)

3.3.1.1 Turn on GSM engine using the ignition line IGT (Power on)

To switch on MC35i the /IGT (Ignition) signal needs to be driven to ground level for at least 100ms. This can be accomplished using an open drain/collector driver in order to avoid current flowing into this pin.

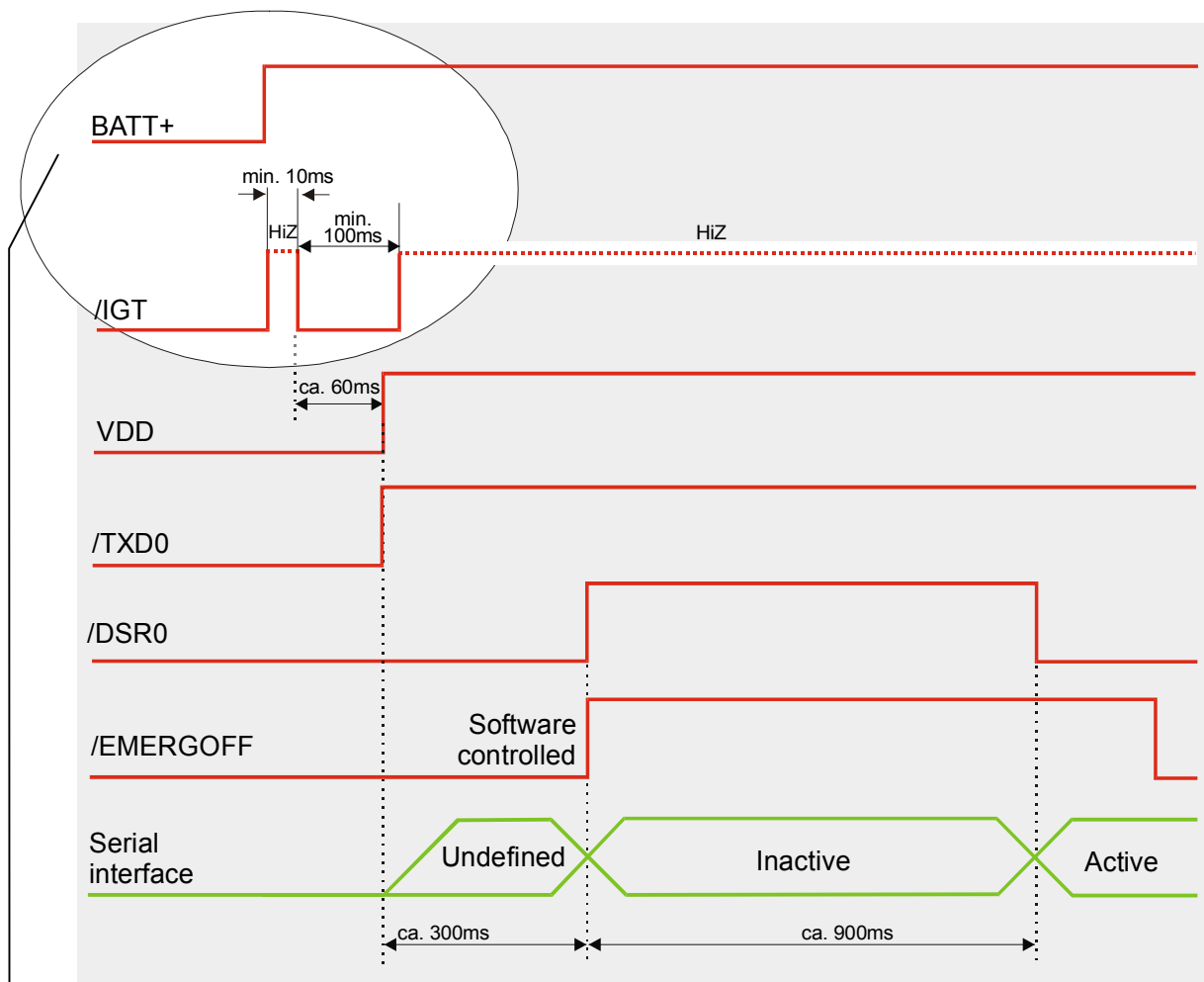

For details please see Chapter 3.3.1.2

Figure 4: Power-on by ignition signal

If configured to a fix baud rate, MC35i will send the result code `^SYSSTART` to indicate that it is ready to operate. This result code does not appear when autobauding is active. See chapter AT+IPR in [1].

3.3.1.2 Timing of the ignition process

When designing your application platform take into account that powering up MC35i requires the following steps.

- The ignition line cannot be operated until V_{BATT+} passes the level of 3.0V.
- 10ms after V_{BATT+} has reached 3.0V the ignition line can be switched low. The duration of the falling edge must not exceed 1ms.
- Another 100ms are required to power up the module.
- Ensure that V_{BATT+} does not fall below 3.0V while the ignition line is driven. Otherwise the module cannot be activated. If the VDDL P line is fed from an external power supply, the /IGT line is HiZ before the rising edge of V_{BATT+} .
- If the VDDL P line is fed from an external power supply as explained in Chapter 3.5, the /IGT line is HiZ before the rising edge of V_{BATT+} .

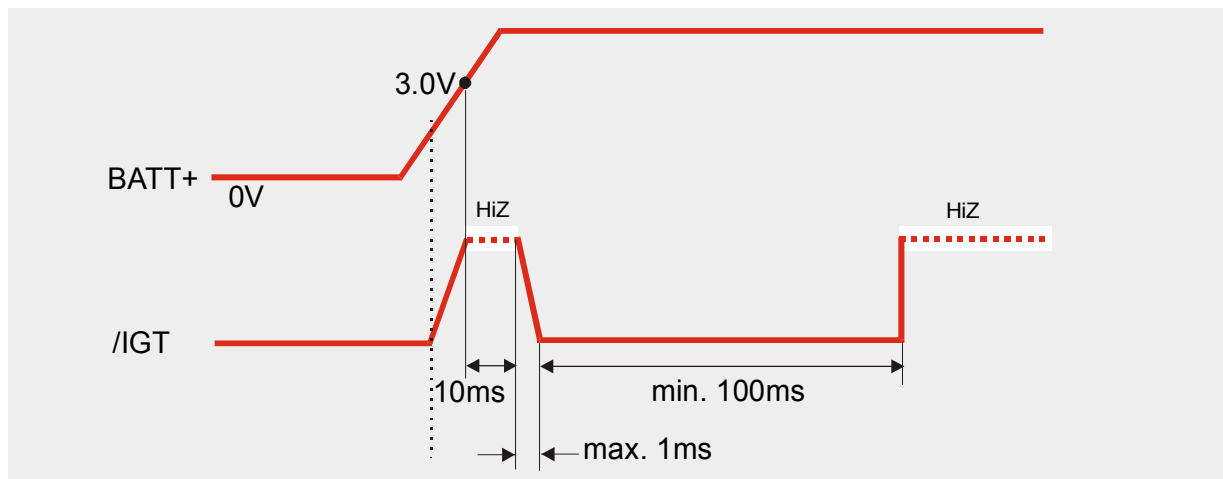

Figure 5: Timing of power-on process if VDDL P is not used

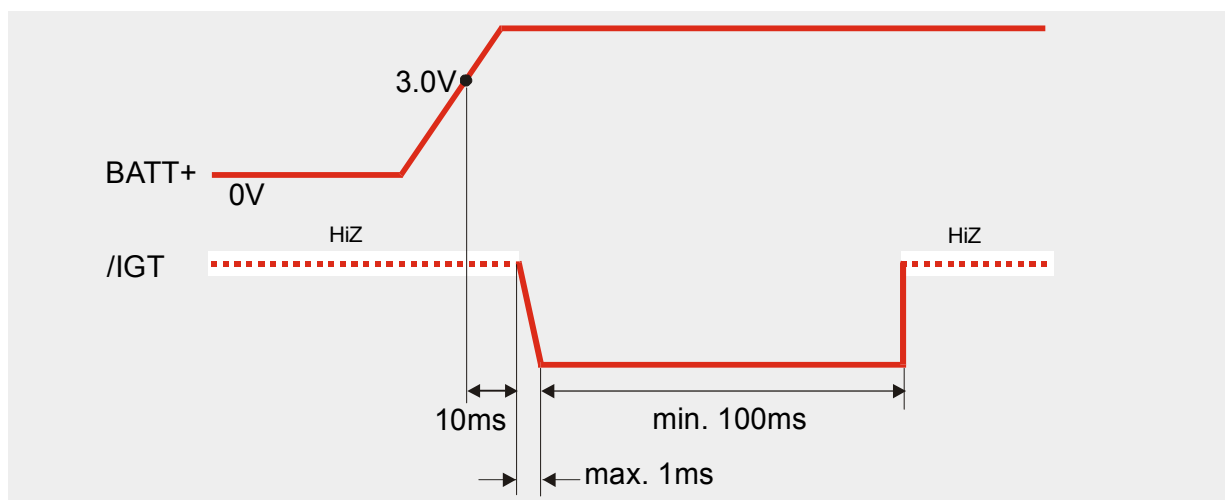

Figure 6: Timing of power-on process if VDDL P is fed from external source

3.3.1.3 Turn on GSM engine using the RTC (Alarm mode)

Another power-on approach is to use the RTC, which is constantly supplied with power from a separate voltage regulator in the power supply ASIC. The RTC provides an alert function which allows to wake up MC35i from POWER DOWN mode. To prevent the engine from unintentionally logging into the GSM network, this procedure only enables restricted operation, referred to as Alarm mode. It must not be confused with a wake-up or alarm call that can be activated by using the same AT command, but without switching off power.

Use the *AT+CALA* command to set the alarm time. The RTC retains the alarm time if the GSM engine was powered down by *AT^SMSO*. Once the alarm is timed out and executed, MC35i enters into the Alarm mode. This is indicated by an Unsolicited Result Code (URC) which reads:

```
^SYSSTART ALARM MODE
```

In Alarm mode only a limited number of AT commands is available. For further instructions refer to the AT Command Set.

Table 5: AT commands available in Alarm mode

AT command	Use
AT+CALA	Set alarm time
AT+CCLK	Set date and time of RTC
AT^SBC	Query average current consumption of MC35i, enable / disable undervoltage URCs (see Chapter 3.3.3.1)
AT^SCTM	Query temperature range, enable/disable URCs to report critical temperature ranges
AT^SMSO	Power down GSM engine

For the GSM engine to change from the Alarm mode to full operation (normal operating mode) it is necessary to drive the ignition line to ground. This must be implemented in your host application as described in Chapter 3.3.1.1

If your host application uses the SYNC pin to control a status LED as described in Chapter 3.9.2.2, please note that the LED is off while the GSM engine is in Alarm mode.

3.3.2 Turn off MC35i

To switch the module off the following procedures may be used:

- *Normal procedure*: Software controlled by sending AT^SMSO command over the serial application interface. See Chapter 3.3.2.1.
- *Emergency shutdown*: Hardware driven by switching the /EMERGOFF line of the ZIF connector to ground = immediate shutdown of supply voltages, only applicable if the software controlled procedure fails! See Chapter 3.3.2.3.
- *Automatic shutdown*: See Chapter 3.3.3.
Takes effect if undervoltage is detected
Takes effect if MC35i board temperature exceeds critical limit

3.3.2.1 Turn off GSM engine using the AT^SMSO command

The best and safest approach to powering down MC35i is to issue the AT^SMSO command. This procedure lets MC35i log off from the network and allows the software to enter into a secure state and save data before disconnecting the power supply. The mode is referred to as POWER DOWN mode. In this mode, only the RTC stays active.

Before switching off the device sends the result code

```
^SMSO: MS OFF
```

```
OK
```

```
^SHUTDOWN
```

After sending AT^SMSO do not enter any other AT commands. There are two ways to verify when the module turns off:

- Wait for the URC “^SHUTDOWN”. It indicates that all important data have been stored to the Flash and that the complete system turns off in less than 1 second.
- Also, you can monitor the VDD pin. The low state of VDD definitely indicates that the module is switched off.

Be sure not to disconnect the operating voltage V_{BATT+} before the URC “^SHUTDOWN” has been issued and the VDD signal has gone low. Otherwise you run the risk of losing data.

While MC35i is in POWER DOWN mode the application interface is switched off and must not be fed from any other source. Therefore, your application must be designed to avoid any current flow into any digital pins of the application interface.

Note: In POWER DOWN mode, the /EMERGOFF pin and the output pins of the serial interface /RXD0, /CTS0, /DCD0, /DSR0 and /RING0 are switched to high impedance state.

If this causes the associated input pins of your application to float, you are advised to integrate an additional resistor (100 k Ω – 1 M Ω) at each line. In the case of the /EMERGOFF pin use a pull-down resistor tied to GND. In the case of the serial interface pins you can either connect pull-up resistors to the VDD line, or pull-down resistors to GND.

3.3.2.2 Maximum number of turn-on / turn-off cycles

Each time the module is shut down, data will be written from volatile memory to flash memory. The guaranteed maximum number of write cycles is limited to 100.000.

3.3.2.3 Emergency shutdown using /EMERGOFF pin

Caution: Use the /EMERGOFF pin only when, due to serious problems, the software is not responding for more than 5 seconds. Pulling the /EMERGOFF pin causes the loss of all information stored in the volatile memory since power is cut off immediately. Therefore, this procedure is intended only for use in case of emergency, e.g. if the host controller experienced a watchdog reset and afterwards MC35i fails to shut down properly or fails to respond.

The /EMERGOFF signal is available on the ZIF connector. To control the /EMERGOFF line it is recommended to use an open drain / collector driver. To turn the GSM engine off, the /EMERGOFF line has to be driven to ground for ≥ 3.2 s.

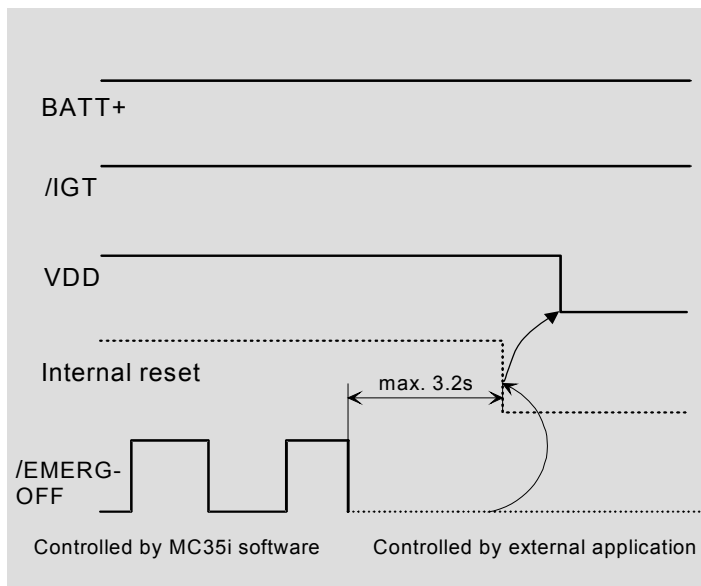

Figure 7: Deactivating GSM engine by Power Down signal

How does it work:

- Voltage V_{BATT+} is permanently applied to the module.
- The module is active while the internal reset signal is kept at high potential.

During operation, the baseband controller generates watchdog pulses at regular intervals.

When the /EMERGOFF pin is grounded these watchdog pulses are cut off from the power supply ASIC. The power supply ASIC shuts down the internal supply voltages of MC35i after max. 3.2s and the module turns off. Consequently the output voltage at VDD is switched off.

3.3.3 Automatic shutdown

Automatic shutdown takes effect if the supply voltage or the temperature of MC35i are exceeding critical limits. The shutdown procedure is equivalent to the power-down initiated with the AT^SMSO command: MC35i logs off from the network and the software enters a secure state avoiding loss of data.

3.3.3.1 Undervoltage shutdown

If the supply voltage falls below the range specified in Chapters 5.3 and 5.4, MC35i ceases to operate. This avoids that the module violates GSM specifications. Undervoltage conditions may be reported by the Unsolicited Result Code

AT^SBC: Undervoltage.

To activate or deactivate the presentation of the URC use the AT^SBC command described in [1].

3.3.3.2 Temperature dependent shutdown

The board temperature is constantly monitored by an internal NTC resistor located on the PCB. The values are measured directly on the board and therefore, are not fully identical with the ambient temperature.

During a guard period of two minutes after power-up, the module will not switch off, even if the critical temperature is exceeded. This allows the user to make an emergency call or a call to a predefined phone number, before the module switches off. See Chapter 3.3.3.3 for details.

Each time the board temperature goes out of range or back to normal, MC35i instantly displays an alert in the form of a URC (if enabled).

- URCs indicating the level "1" or "-1" allow the user to take appropriate precautions, such as protecting the module from exposure to extreme conditions. The presentation of the URCs depends on the settings selected with the AT^SCTM write command:
 - AT^SCTM=0 (default): Presentation of URCs is enabled during the two minute guard period after start-up of MC35i. After expiry of the two minute guard period, the presentation will be disabled, i.e. no URCs with alert levels "1" or "-1" will be generated.
 - AT^SCTM=1: Presentation of URCs is always enabled.
- URCs indicating the level "2" or "-2" are instantly followed by an orderly shutdown, except in the cases described in Chapter 3.3.3.3. The presentation of these URCs is always enabled, i.e. they will be output even though the default setting AT^SCTM=0 was never changed.

Table 6: Temperature dependent behavior

Sending temperature warning (2min after MC35i start-up, otherwise only if URC presentation enabled)	
^SCTM_B: 1	Caution: T_{amb} of board close to overtemperature limit.
^SCTM_B: -1	Caution: T_{amb} of board close to undertemperature limit.
^SBCTM_B: 0	Board back to uncritical temperature range.
Automatic shutdown (URC appears no matter whether presentation was enabled)	
^SCTM_B: 2	Alert: T_{amb} of board $\geq 70^{\circ}\text{C}$. MC35i switches off.
^SCTM_B: -2	Alert: T_{amb} of board $\leq -25^{\circ}\text{C}$. MC35i switches off.

The values stated in Table 6 are based on test conditions according to IEC 60068-2-2 (still air).

3.3.3.3 Deferred shutdown at extreme temperature conditions

In the following cases, shutdown will be deferred if a critical temperature limit is exceeded:

- while an emergency call is in progress
- while a call to a predefined phone number is in progress
- during a two minute guard period after power up. This guard period has been introduced in order to allow the user to make an emergency call or a call to a phone number predefined with the AT^SCTM command (see [1] for details). The start of any of these calls extends the guard period until the end of the call. Any other network activity may be terminated by shutdown upon expiry of the guard time.

If the temperature is still out of range after the guard period expires or the call ends, the module switches off immediately (without another alert message).

CAUTION! Automatic shutdown is a safety feature intended to prevent damage to the module. Extended usage of the deferred shutdown functionality may result in damage to the module, and possibly other severe consequences.

3.3.3.4 Monitoring the board temperature of MC35i

The AT^SCTM command can also be used to check the present status of the board. Depending on the selected mode, the read command returns the current board temperature in degrees Celsius or only a value that indicates whether the board is within the safe or critical temperature range. See [1] for further instructions.

3.3.4 Summary of state transitions (except SLEEP mode)

Table 7 shows how to proceed from one mode to another (gray column = present mode, white columns = intended modes)

Table 7: State transitions of MC35i

Further mode →→→ Present mode	POWER DOWN	Normal mode	ALARM mode
POWER DOWN mode	---	/IGT >100 ms at low level	RTC alarm (if activated with AT+CALA before powering down MC35i).
Normal mode	AT^SMSO or exceptionally /EMERGOFF pin ≥3.2s at low level	---	AT+CALA followed by AT^SMSO. MC35i enters Alarm mode when specified time is reached.
ALARM mode	AT^SMSO or exceptionally /EMERGOFF pin ≥3.2s at low level	/IGT > 100 ms at low level	---

^{*)} Normal mode covers TALK, IDLE and SLEEP modes

3.4 Power saving

SLEEP mode reduces the functionality of the MC35i module to a minimum and, thus, minimizes the current consumption to the lowest level. Settings can be made using the AT+CFUN command. For details see below and [1]. SLEEP mode falls into two categories:

- NON-CYCLIC SLEEP mode AT+CFUN=0
- CYCLIC SLEEP modes, selectable with AT+CFUN=5, 6, 7 or 8.

IMPORTANT: Please keep in mind that power saving works properly only when PIN authentication has been done. If you attempt to activate power saving while the SIM card is not inserted or the PIN not correctly entered (Limited Network Service), the selected <fun> level will be set, though power saving does not take effect. For the same reason, power saving cannot be used if MC35i operates in Alarm mode.

To check whether power saving is on, you can query the status using the read command AT+CFUN? if you have chosen CYCLIC SLEEP mode. If available, you can check the status LED (if an LED is connected to the SYNC pin as specified in Chapter 3.9.2.2). The LED is off in all SLEEP modes when no activity occurs, but resumes flashing to indicate temporary wake-up states during CYCLIC SLEEP modes. The LED patterns are shown in Table 13.

The wake-up procedures are quite different depending on the selected SLEEP mode. Table 8 compares the wake-up events that can occur in NON-CYCLIC and CYCLIC SLEEP modes.

3.4.1 No power saving (AT+CFUN=1)

The functionality level <fun>=1 is where power saving is switched off. This is the default after startup.

3.4.2 NON-CYCLIC SLEEP mode (AT+CFUN=0)

If level 0 has been selected (AT+CFUN=0), the serial interface is blocked. Level 0 is called NON-CYCLIC SLEEP mode, since the serial interface is not alternatingly made accessible as in CYCLIC SLEEP mode.

The first wake-up event fully activates the module, enables the serial interface and terminates the power saving mode. In short, it takes MC35i back to the highest level of functionality <fun>=1. /RTS0 or /RTS1 are not used for flow control, but to wake up the module.

To activate NON-CYCLIC SLEEP mode, enter the command AT+CFUN=0. Please note that after receiving AT+CFUN=0 the module waits 2 seconds before entering the power saving mode.

3.4.3 CYCLIC SLEEP mode (AT+CFUN=5, 6, 7 and 8)

The functionality levels AT+CFUN=5, AT+CFUN=6, AT+CFUN=7 and AT+CFUN=8 are referred to as CYCLIC SLEEP modes.

The major benefit of all CYCLIC SLEEP modes is that the serial interface remains accessible, and that, in intermittent wake-up periods, characters can be sent or received without terminating the selected mode. The best choice is using AT+CFUN=7 or 8, since in these modes MC35i automatically resumes power saving, after you have sent or received a short message, made a call or completed a GPRS transfer. CFUN=5 and 6 do not offer this feature in all events, and therefore, are only supported for compatibility with earlier releases. In all CYCLIC SLEEP modes, you can enter AT+CFUN=1 to permanently wake up MC35i and take it back to full functionality. Please refer to Table 8 for a summary of all modes.

For CYCLIC SLEEP mode, both the application and the module must be configured to use hardware flow control (RTS/CTS handshake). This is necessary since by activating the /CTS signal, the module indicates to the application when the UART is active (see Chapter 3.4.4 for details). The default setting of MC35i is AT\Q0 (no flow control) which must be altered to AT\Q3. See [1] for details.

3.4.4 Timing of the /CTS signal in CYCLIC SLEEP modes

The /CTS signal is enabled in synchrony with the module's paging cycle. It goes active low each time when the module starts listening to a paging message block from the base station. The timing of the paging cycle varies with the base station. The duration of a paging interval can be calculated from the following formula:

$$4.615 \text{ ms (TDMA frame duration)} * 51 \text{ (number of frames)} * \text{DRX value.}$$

DRX (Discontinuous Reception) is a value from 2 to 9, resulting in paging intervals from 0.47 to 2.12 seconds. The DRX value of the base station is assigned by the network operator.

Each listening period causes the /CTS signal to go active low: If DRX is 2, the /CTS signal is activated every 0.47 seconds, if DRX is 3, the /CTS signal is activated every 0.71 seconds and if DRX is 9, the /CTS signal is activated every 2.1 seconds.

The /CTS signal is active low for 4.6 ms. This is followed by another 4.6 ms UART activity. If the start bit of a received character is detected within these 9.2 ms, /CTS will be activated and the proper reception of the character will be guaranteed.

/CTS will also be activated if any character is to be sent from the module to the application.

After the last character was sent or received the interface will remain active for another

- 2 seconds, if AT+CFUN=5 or 7 or
- 10 minutes, if AT+CFUN=6 or 8.

In the pauses between listening to paging messages, while /CTS is high, the module resumes power saving and the AT interface is not accessible. See Figure 8 and Figure 9.

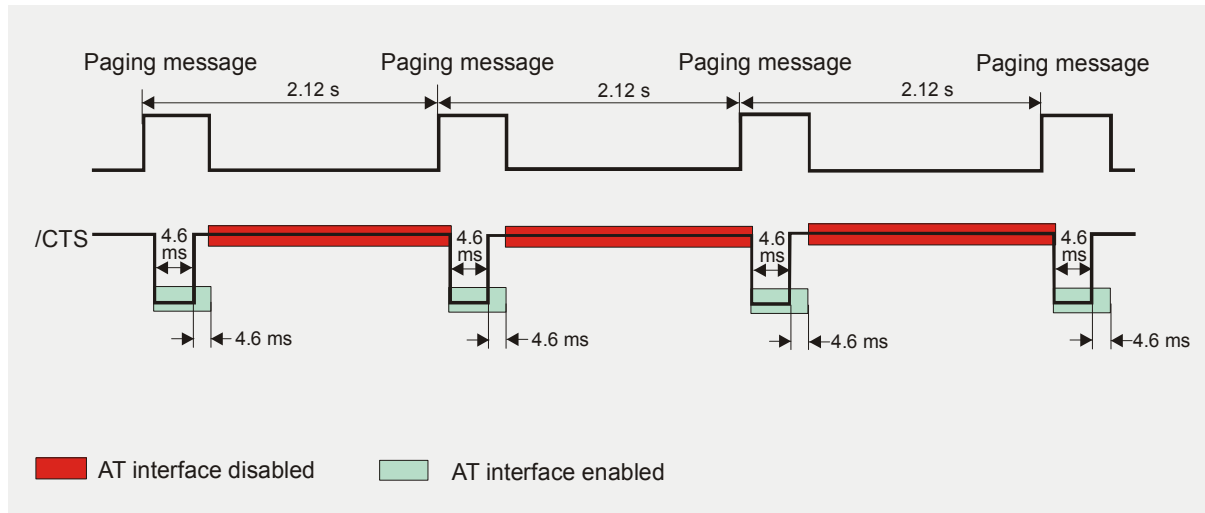

Figure 8: Timing of /CTS signal (example for a 2.12 s paging cycle)

Figure 9 illustrates the CFUN=5 mode, which resets the /CTS signal 2 seconds after the last character was sent or received.

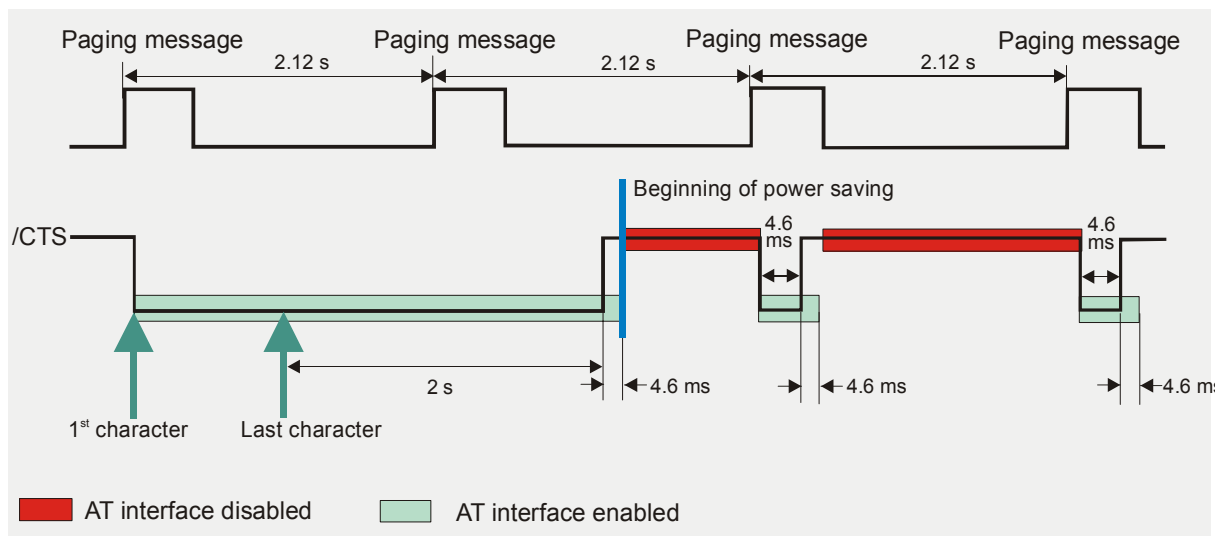

Figure 9: Beginning of power saving if CFUN=5

3.4.5 Wake up MC35i from SLEEP mode

A wake-up event is any event that causes the module to draw current. Depending on the selected mode the wake-up event either switches SLEEP mode off and takes MC35i back to AT+CFUN=1, or activates MC35i temporarily without leaving the current SLEEP mode.

Definitions of the state transitions described in Table 8:

- Quit = MC35i exits SLEEP mode and returns to AT+CFUN=1.
- Temporary = MC35i becomes active temporarily for the duration of the event and the mode-specific follow-up time after the last character was sent or received on the serial interface.
- No effect: = Event is not relevant in the selected SLEEP mode. MC35i does not wake up.

Table 8: Wake-up events in NON-CYCLIC and CYCLIC SLEEP modes

Event	From SLEEP mode AT+CFUN=0 to AT+CFUN=1	From SLEEP mode AT+CFUN=5 or 6 to AT+CFUN=1	From SLEEP mode AT+CFUN=7 or 8 to AT+CFUN=1
Ignition line	No effect	No effect	No effect
/RTS0 (falling edge) ¹⁾	Quit ¹⁾	No effect (RTS is only used for flow control)	No effect (RTS is only used for flow control)
Unsolicited Result Code (URC)	Quit	Quit	Temporary
Incoming voice or data call	Quit	Quit	Temporary
Any AT command (incl. outgoing voice or data call, outgoing SMS)	Not possible (UART disabled)	Temporary	Temporary
Incoming SMS depending on mode selected by AT+CNMI: AT+CNMI=0,0 (= default, no indication of received SMS)	No effect	No effect	No effect
AT+CNMI=1,1 (= displays URC upon receipt of SMS)	Quit	Quit	Temporary
GPRS data transfer	Not possible (UART disabled)	Temporary	Temporary
RTC alarm ²⁾	Quit	Quit	Temporary
AT+CFUN=1	Not possible (UART disabled)	Quit	Quit

¹⁾ During all CYCLIC SLEEP modes, /RTS0 is conventionally used for flow control: The assertion of /RTS0 signals that the application is ready to receive data - without waking up the module. Be aware that this behavior is different if CFUN=0: In this case, the assertion of /RTS0 serves as a wake-up event, giving the application the possibility to intentionally terminate power saving.

²⁾ Recommendation: In NON-CYCLIC SLEEP mode, you can set an RTC alarm to wake up MC35i and return to full functionality. This is a useful approach because, in this mode, the AT interface is not accessible.

3.5 RTC backup

The internal Real Time Clock of MC35i is supplied from a dedicated voltage regulator in the power supply ASIC which is also active when MC35i is in POWER DOWN status. An alarm function is included that allows to wake up MC35i without logging on to the GSM network.

In addition, you can use the VDDL P pin on the ZIF connector (pin no. 30) to backup the RTC from an external capacitor. If the voltage supply at BATT+ is disconnected the RTC can be powered by the capacitor. The size of the capacitor determines the duration of buffering when no voltage is applied to the module, i.e. the greater capacitor the longer MC35i will save the date and time.

If you need to adjust the date and time use the AT+CCLK command. To set the alarm time enter AT+CALA. For further instructions please refer to Chapter 3.3.1.3 and to [1].

A serial resistor placed on the board next to the VDDL P line limits the input current of an empty capacitor.

The voltage applied at VDDL P can be in the range from 2 to 5.5V. Please refer to Table 21 for the parameters required.

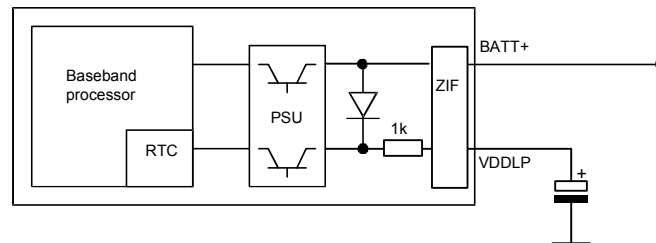

Figure 10: RTC supply from capacitor

Note: The VDDL P voltage should be kept below the minimum BATT+ voltage. This is significant to prevent the GSM engine from being powered over the RTC backup battery. Please refer to Chapter 5.3. for more information. The reference voltage listed in Table 21 are values measured directly on the MC35i GSM / GPRS engine. They do not apply to the accessories connected.

3.6 Serial interface

MC35i offers an 8-wire, unbalanced, asynchronous serial interface conforming to ITU-T V.24 protocol DCE signaling. The electrical characteristics do not comply with ITU-T V.28. The significant levels are 0V (for low data bit or ON condition) and 2.65V (for high data bit or OFF condition). For electrical characteristics please refer to Table 21.

MC35i is designed for use as a DCE. Based on the conventions for DCE-DTE connections it communicates with the customer application (DTE) using the following signals:

- Port /TXD @ application sends data to the module's /TXD0 signal line
- Port /RXD @ application receives data from the module's /RXD0 signal line

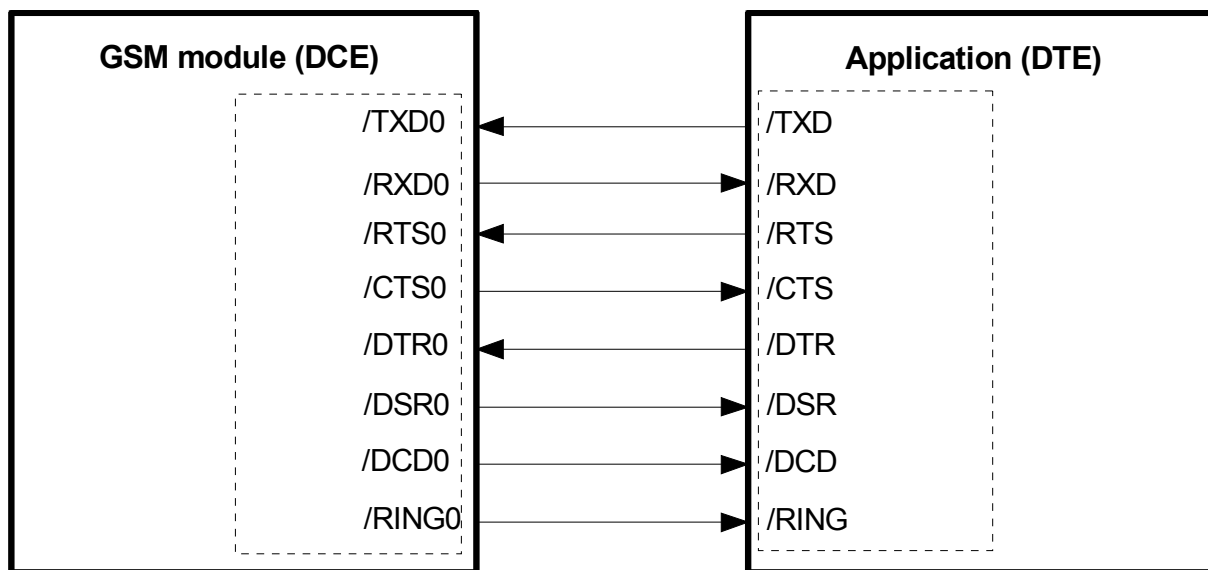

Figure 11: Serial interface

Table 9: DCE-DTE wiring

V.24 circuit	DCE		DTE	
	Pin function	Signal direction	Pin function	Signal direction
103	/TXD0	Input	/TXD	Output
104	/RXD0	Output	/RXD	Input
105	/RTS0	Input	/RTS	Output
106	/CTS0	Output	/CTS	Input
108/2	/DTR0	Input	/DTR	Output
107	/DSR0	Output	/DSR	Input
109	/DCD0	Output	/DCD	Input
125	/RING0	Output	/RING	Input

Features of the serial interface:

- Designed for voice, CSD, fax, GPRS services and for controlling the GSM engine with AT commands.
- Full Multiplex capability allows the interface to be partitioned into three virtual channels, yet with CSD and fax services only available on the first logical channel.
- Includes the data lines /TXD0 and /RXD0, the status lines /RTS0 and /CTS0 and, in addition, the modem control lines /DTR0, /DSR0, /DCD0 and /RING0.
- The /DTR0 signal will only be polled once per second from the internal firmware of MC35i. The /RING0 signal serves to indicate incoming calls and other types of URCs (Unsolicited Result Code).
- Configured for 8 data bits, no parity and 1 stop bit.
- Can be operated at bit rates from 300bps to 230400 bps.
- Autobauding supports the following bit rates: 4800, 9600, 19200, 38400, 57600, 115200, 230400 bps.
- Supports hardware handshake using RTS0/CTS0 and XON/XOFF software flow control.

3.7 Audio interface

MC35i comprises two analog audio interfaces each with a balanced analog microphone input and a balanced analog earpiece output. Both microphone inputs are powered from the same supply circuit to feed active microphones.

This means you can connect two audio devices in any combination, both at the same time. Using the AT^SAIC command you can easily switch back and forth between both audio interfaces.

MC35i offers six audio modes which can be selected with the AT^SNFS command. There is a default assignment of the audio interface for each audio mode (see Table 24) which can be temporarily changed with AT^SAIC and also saved with AT^SNFW within the currently selected audio mode (except audio mode 1). The electrical characteristics of the voiceband part vary with the audio mode. For example, sending and receiving amplification, sidetone paths, noise suppression etc. depend on the selected mode and can be altered with the AT commands (except for mode 1).

Please refer to Chapter 5.5 for specifications of the audio interface and an overview of the audio parameters. Detailed instructions on using AT commands are presented in [1]. Table 24 summarizes the characteristics of the various audio modes and shows what parameters are supported in each mode.

When shipped from factory, interface 1 and audio mode 1 are activated. This is the default configuration optimized for the Votronic HH-SI-30.3/1.1/0 handset and used for type approving the Siemens reference configuration. Audio mode 1 has fix parameters which cannot be modified. To adjust the settings of the Votronic handset simply change to another audio mode.

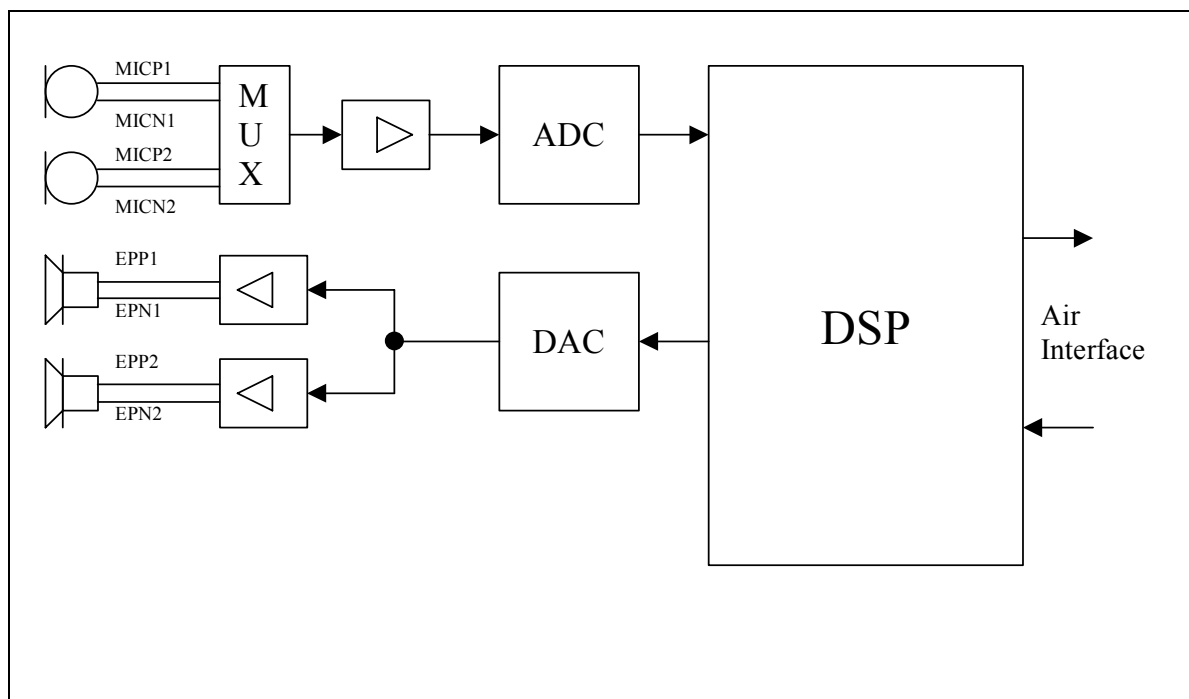

Figure 12: Audio block diagram

3.7.1 Speech processing

The speech samples from the ADC are handled by the DSP of the baseband controller to calculate e.g. amplifications, sidetone, echo cancellation or noise suppression depending on the configuration of the active audio mode. These processed samples are passed to the speech encoder. Received samples from the speech decoder are passed to the DAC after post processing (frequency response correction, adding sidetone etc.).

Full rate, half rate, enhanced full rate, speech and channel encoding including voice activity detection (VAD) and discontinuous transmission (DTX) and digital GMSK modulation are also performed on the GSM baseband processor.

Customer specific audio parameters can be evaluated by Siemens on customer request. These parameters can be downloaded to MC35i using the appropriate AT command. For further details refer to [9] or contact your local Siemens dealer.

3.8 SIM interface

The baseband processor has an integrated SIM interface compatible with the ISO 7816 IC Card standard. This is wired to the host interface (ZIF connector) in order to be connected to an external SIM card holder. Six pins on the ZIF connector are reserved for the SIM interface.

The CCIN pin serves to detect whether a tray (with SIM card) is present in the card holder. Using the CCIN pin is mandatory for compliance with the GSM 11.11 recommendation if the mechanical design of the host application allows the user to remove the SIM card during operation. See Chapter 3.8.1 for details.

Table 10: Signals of the SIM interface (ZIF connector)

Signal	Description
CCGND	Separate ground connection for SIM card to improve EMC.
CCCLK	Chipcard clock, various clock rates can be set in the baseband processor.
CCVCC	SIM supply voltage from PSU-ASIC
CCIO	Serial data line, input and output.
CCRST	Chipcard reset, provided by baseband processor.
CCIN	Input on the baseband processor for detecting a SIM card tray in the holder. The CCIN pin is mandatory for applications that allow the user to remove the SIM card during operation. The CCIN pin is solely intended for use with a SIM card. It must not be used for any other purposes. Failure to comply with this requirement may invalidate the type approval of MC35i.

It is recommended that the total cable length between the ZIF connector pins on MC35i and the pins of the SIM card holder does not exceed 200 mm in order to meet the specifications of 3GPP TS 51.010-1 and to satisfy the requirements of EMC compliance.

To avoid possible cross-talk from the CCCLK signal to the CCIO signal be careful that both lines are not placed closely next to each other. A useful approach is using the CCGND line to shield the CCIO line from the CCCLK line.

3.8.1 Requirements for using the CCIN pin

According to ISO/IEC 7816-3 the SIM interface must be immediately shut down once the SIM card is removed during operation. Therefore, the signal at the CCIN pin must go low *before* the SIM card contacts are mechanically detached from the SIM interface contacts. This shutdown procedure is particularly required to protect the SIM card as well as the SIM interface of MC35i from damage.

An appropriate SIM card detect switch is required on the card holder. For example, this is true for the model supplied by Molex, which has been tested to operate with MC35i and is part of the Siemens reference equipment submitted for type approval. Molex ordering number is 91228-0001, see also Chapter 8.

The module's startup procedure involves a SIM card initialization performed within 1 second after getting started. An important issue is whether the initialization procedure ends up with a high or low level of the CCIN signal:

- a) If, during startup of MC35i, the CCIN signal on the SIM interface is high, then the status of the SIM card holder can be recognized each time the card is inserted or ejected.
A low level of CCIN indicates that no SIM card tray is inserted into the holder. In this case, the module keeps searching, at regular intervals, for the SIM card. Once the SIM card tray with a SIM card is inserted, CCIN is taken high again.
- b) If, during startup of MC35i, the CCIN signal is low, the module will also attempt to initialize the SIM card. In this case, the initializing will only be successful when the card is present.
If the SIM card initializing has been done, but the card is no more operational or removed, then the module will never search again for a SIM card and only emergency calls can be made.

Removing and inserting the SIM card during operation requires the software to be reinitialized. Therefore, after reinserting the SIM card it is necessary to restart MC35i. It is strongly recommended to connect the contacts of the SIM card detect switch to the CCIN input and to the CCVCC output of the module as illustrated in the sample diagram in Figure 13.

Note: No guarantee can be given, nor any liability accepted, if loss of data is encountered after removing the SIM card during operation.

Also, no guarantee can be given for properly initializing any SIM card that the user inserts after having removed a SIM card during operation. In this case, the application must restart MC35i.

3.8.2 Design considerations for SIM card holder

The schematic below is a sample configuration that illustrates the Molex SIM card holder located on the DSB35 Support Box (evaluation kit used for type approval of the Siemens MC35i reference setup, see [4] for technical details). X1201 is the designation used in [4] to refer to the SIM card holder.

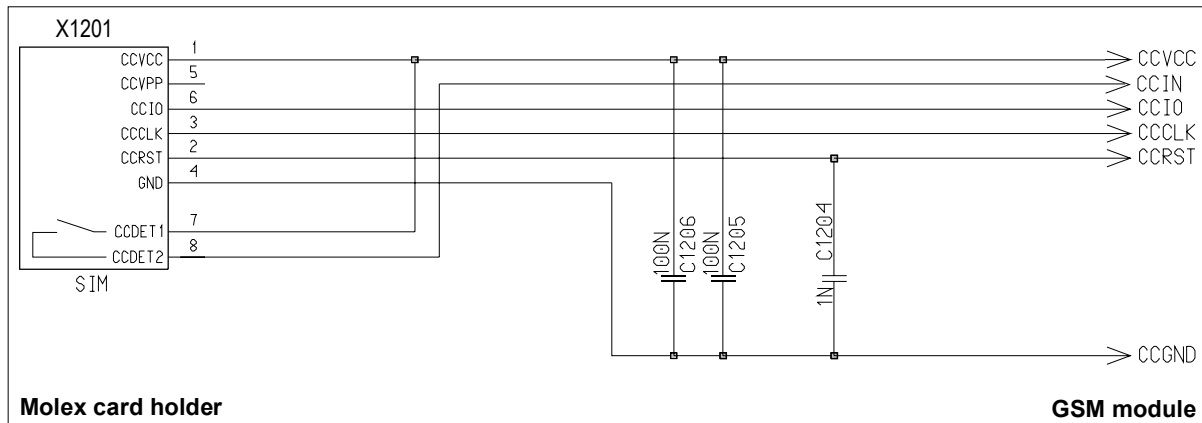

Figure 13: SIM card holder of DSB35 Support Box

Table 11: Pin assignment of Molex SIM card holder on DSB35 Support Box

Pin no.	Signal name	I/O	Function
1	CCVCC	I	Supply voltage for SIM card, generated by the GSM engine
2	CCRST	I	Chip card reset, prompted by the GSM engine
3	CCCLK	I	Chip card clock
4	CCGND	-	Individual ground line for the SIM card to improve EMC
5	CCVPP	-	Not connected
6	CCIO	I/O	Serial data line, bi-directional
7	CCDET1	-	Connect to CCVCC
8	CCDET2	-	Connects to the CCIN input of the GSM engine. Serves to recognize whether a SIM card is in the holder.

Pins 1 through 8 (except for 5) are the minimum requirement according to the GSM Recommendations, where pins 7 and 8 are needed for SIM card tray detection through the CCIN pin.

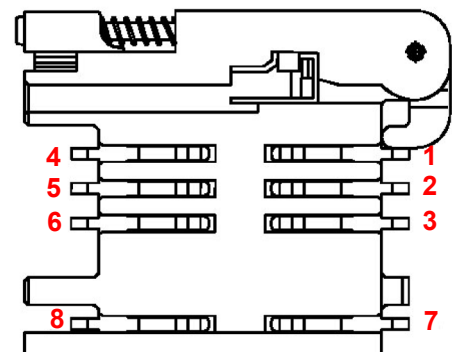

Figure 14: Pin numbers of Molex SIM card holder on DSB35 Support Box

Place the capacitors C1205 and C1206 (or instead one capacitor of 200nF) as close as possible to the pins 1 (CCVCC) and 4 (GND) of the card holder. Connect the capacitors to the pins via low resistance tracks.

3.9 Control signals

3.9.1 Inputs

Table 12: Input control signals of the MC35i module

Signal	Pin	Pin status	Function	Remarks
Ignition	/IGT	= falling edge	Power up MC35i	Active low \geq 100ms (open drain/collector driver required in cellular device application)
		= 1	Hi-Z	
Emergency shutdown	/EMERG-OFF	= 0	Power down MC35i	Active low \geq 3.2s (Open drain/collector driver required in cellular device application). At the /EMERGOFF signal the watchdog signal of the GSM engine can be traced (see description in Table 21 and Chapter 3.3.1).
		= 1	Hi-Z	

(HiZ = high impedance)

3.9.2 Outputs

3.9.2.1 Synchronization signal

The synchronization signal serves to indicate growing power consumption during the transmit burst. The signal is generated by the SYNC pin (pin number 32). Please note that this pin can adopt two different operating modes which you can select by using the AT^SSYNC command (mode 0 and 1). For details refer to the "AT Command Set".

To generate the synchronization signal the pin needs to be configured to mode 0 (= default). This setting is recommended if you want your application to use the synchronization signal for better power supply control. Your platform design must be such that the incoming signal accommodates sufficient power supply to the MC35i module if required. This can be achieved by lowering the current drawn from other components installed in your application.

The timing of the synchronization signal is shown below. High level of the SYNC pin indicates increased power consumption during transmission.

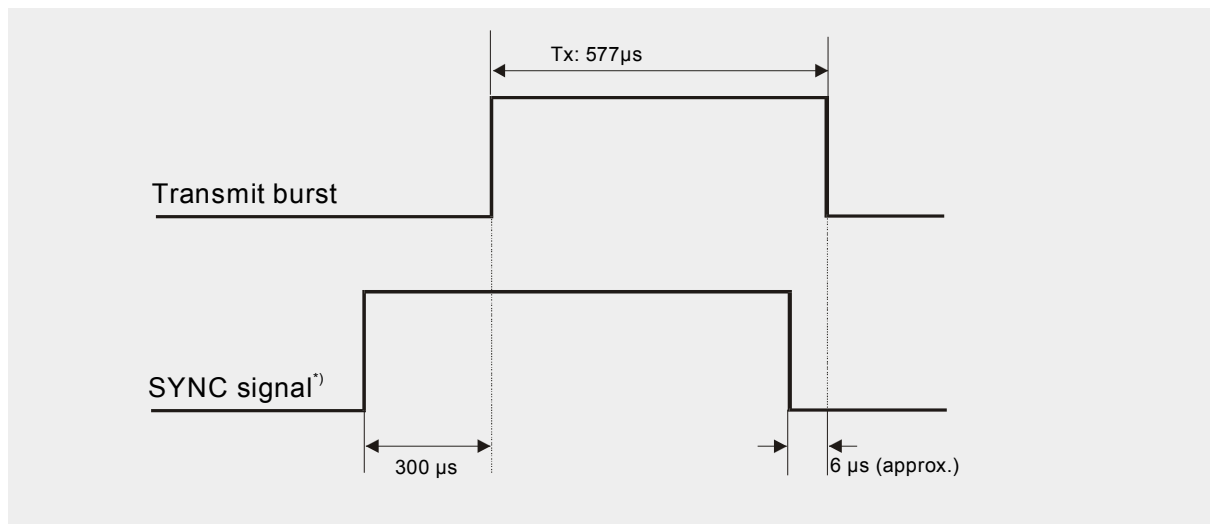

Figure 15: MC35i output control signals

^{*)} The duration of the SYNC signal is always equal, no matter whether the traffic or the access burst are active.

3.9.2.2 Using the SYNC pin to control a status LED

As an alternative to generating the synchronization signal, the SYNC pin can be used to control a status LED on your application platform. Especially in the development and test phase of an application, system integrators are advised to use the LED mode of the SYNC pin in order to evaluate their product design and identify the source of errors.

To avail of this feature you need to set the SYNC pin to mode 1 by using the AT[^]SSYNC command. For details see [1].

When controlled from the SYNC pin the LED can display the functions listed in Table 13. Except for the LED state "off", all LED patterns apply no matter whether MC35i works at full functionality level AT+CFUN=1 or has entered a "temporary wake-up state" during one of the CYCLIC SLEEP modes. See Chapter 3.4 for details on the various SLEEP modes.

Table 13: Coding of the status LED

LED mode	Operating status
Permanently off	MC35i is in one of the following modes: POWER DOWN mode, ALARM mode, SLEEP mode with no wake-up event in progress.
600 ms on / 600 ms off	Limited Network Service: No SIM card inserted or no PIN entered, or network search in progress, or ongoing user authentication, or network login in progress.
75 ms on / 3 s off	IDLE mode: The mobile is logged to the network (monitoring control channels and user interactions). No call in progress.
75 ms on / 75 ms off / 75 ms on / 3 s off	One or more GPRS contexts activated.
0.5 s on / off depending on transmission activity	Packet switched data transfer in progress. LED goes on within 1 second after data packets were exchanged. Flash duration is approximately 0.5 s.
Permanently on	Depending on type of call: <i>Voice call:</i> Connected to remote party. <i>CSD call:</i> Connected to remote party or exchange of parameters while setting up or disconnecting a call.

LED Off = SYNC pin low. LED On = SYNC pin high (if LED is connected as illustrated in Figure 16)

To operate the LED a buffer, e.g. a transistor or gate, must be included in your application. A sample configuration can be gathered from Figure 16. Power consumption in the LED mode is the same as for the synchronization signal mode.

For details see Table 21 pin number 32.

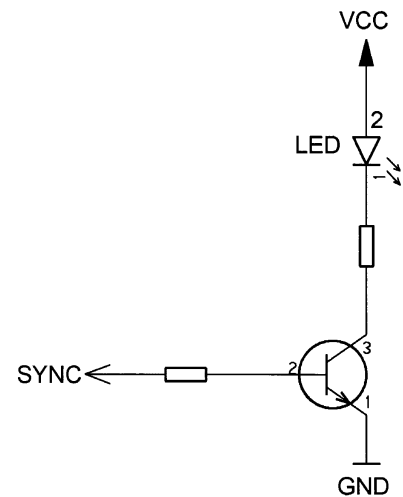

Figure 16: LED Circuit (Example)

3.9.2.3 Behavior of the /RING0 line

The /RING0 line is available on the serial interface (see also Chapter 3.6). The signal serves to indicate incoming calls and other types of URCs (Unsolicited Result Code).

Although not mandatory for use in a host application, it is strongly suggested that you connect the /RING0 line to an interrupt line of your application. In this case, the application can be designed to receive an interrupt when a falling edge on /RING0 occurs. This solution is most effective, particularly, for waking up an application from power saving. Note that if the /RING0 line is not wired, the application would be required to permanently poll the data and status lines of the serial interface at the expense of a higher current consumption. Therefore, utilizing the /RING0 line provides an option to significantly reduce the overall current consumption of your application.

The behavior of the /RING0 line varies with the type of event:

- When a *voice call* comes in the /RING0 line goes low for 1s and high for another 4s. Every 5 seconds the ring string is generated and sent over the /RXD0 line. If there is a call in progress and call waiting is activated for a connected handset or handsfree device, the /RING0 line switches to ground in order to generate acoustic signals that indicate the waiting call.

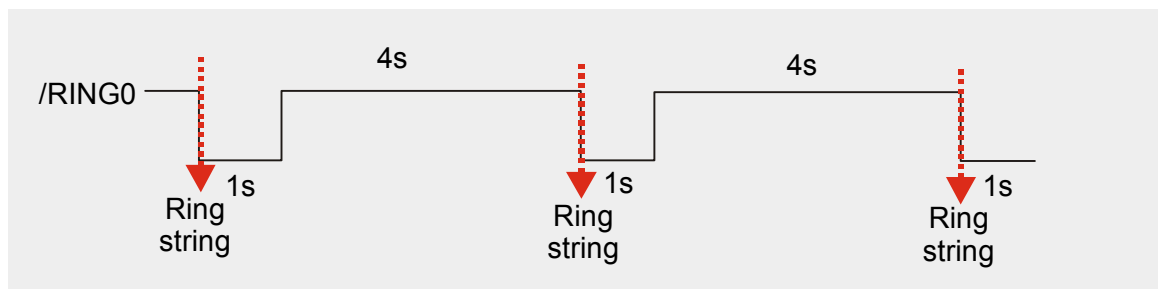

Figure 17: Incoming voice call

- Likewise, when a *Fax or data call* is received, /RING0 goes low. However, in contrast to voice calls, the line remains low. Every 5 seconds the ring string is generated and sent over the /RXD0 line.

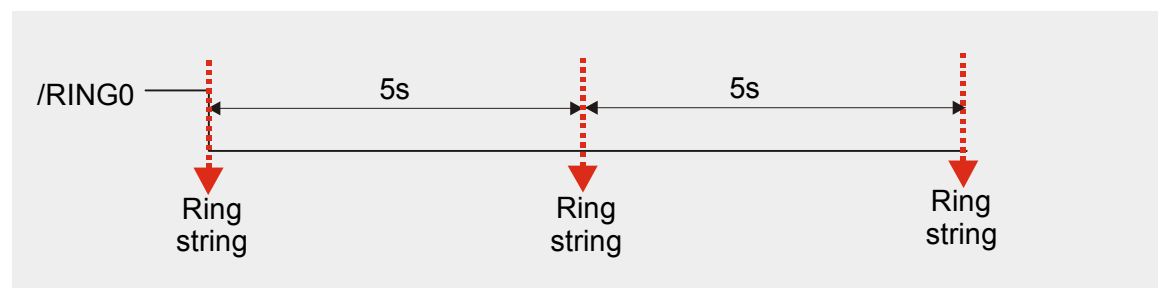

Figure 18: Incoming data call

- All types of Unsolicited Result Codes (URCs) also cause the /RING0 line to go low, however for 1 second only. For example, MC35i may be configured to output a URC upon the receipt of an SMS. As a result, if this URC type was activated with AT+CNMI=1,1, each incoming SMS causes the /RING0 line to go low. See [1] for detailed information on URCs.

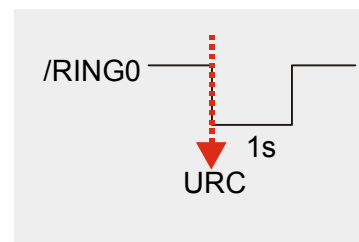

Figure 19: URC transmission

Table 14: MC35i ring signal

Function	Pin	Status	Description
Ring indication	/RING0	0	Indicates an incoming call or URC. If in NON-CYCLIC SLEEP mode CFUN=0 or CYCLIC SLEEP mode CFUN=5 or 6, the module is caused to wake up to full functionality. If CFUN=7 or 8, power saving is resumed after URC transmission or end of call.
		1	No operation

4 RF interface

The RF interface has an impedance of 50Ω. MC35i is capable of sustaining a total mismatch at the antenna connector without any damage, even when transmitting at maximum power level. The antenna jack located on the MC35i PCB is a MuRata GSC coaxial connector (see Figure 20).

The external antenna must be matched properly at least to achieve best performance regarding radiated power, DC-power consumption and harmonic suppression. Please note that the receiver is designed to use the direct conversion concept.

Regarding the return loss MC35i provides the following values.

Table 15: Return loss

State of module	Return loss of module	Recommended return loss of application
Receive	$\geq 8\text{dB}$	$\geq 12\text{dB}$
Transmit	not applicable	$\geq 12\text{dB}$
Idle	$\leq 5\text{dB}$	not applicable

A 27nH inductor to ground provides additional ESD protection for the antenna connector. To protect the inductor from damage no DC voltage must be applied to the antenna circuit.

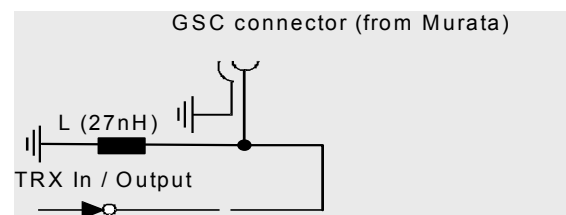

Figure 20: Antenna connector circuit on MC35i

4.1 Antenna connector

MC35i uses a GSC connector to establish the RF connection to the host application. Below please find brief ordering information to help you retrieve further details from the manufacturer MuRata, e.g. under <http://www.murata.com>.

Table 16: MuRata ordering information

Description	MuRata part number
Male connector mounted on MC35i	MM9329-2700
Matching female connectors suited for individual cable assembly <ul style="list-style-type: none"> • Right-angle flexible cable • Right-angle flexible cable • Right-angle semi rigid cable 	MXTK88xxxx MXTK92xxxx MXTK91xxxx

The physical dimensions and maximum mechanical stress limits can be gathered from the table and the figures below. To securely fasten or remove the antenna cable MuRata recommends to use the P/N M22001 engagement/disengagement tool.

Table 17: Ratings and characteristics of the GSC antenna connector

Item	Specification	
Frequency range	DC to 6GHz	
VSWR	1.2 max. (DC to 3 GHz), 1.3 max. 3GHz to 6GHz)	
Nominal impedance	50Ω	
Temperature range	-40°C to +90°C	
Contact resistance	15mΩ max.	
Withstanding voltage	AC300V	
Insulation resistance	500MΩ min.	
Material and finish	Material:	Finish:
<ul style="list-style-type: none"> • Center contact: • Outer contact: • Insulator: 	<ul style="list-style-type: none"> • Copper alloy • Copper alloy • Engineering plastic 	<ul style="list-style-type: none"> Gold plated Silver plated None

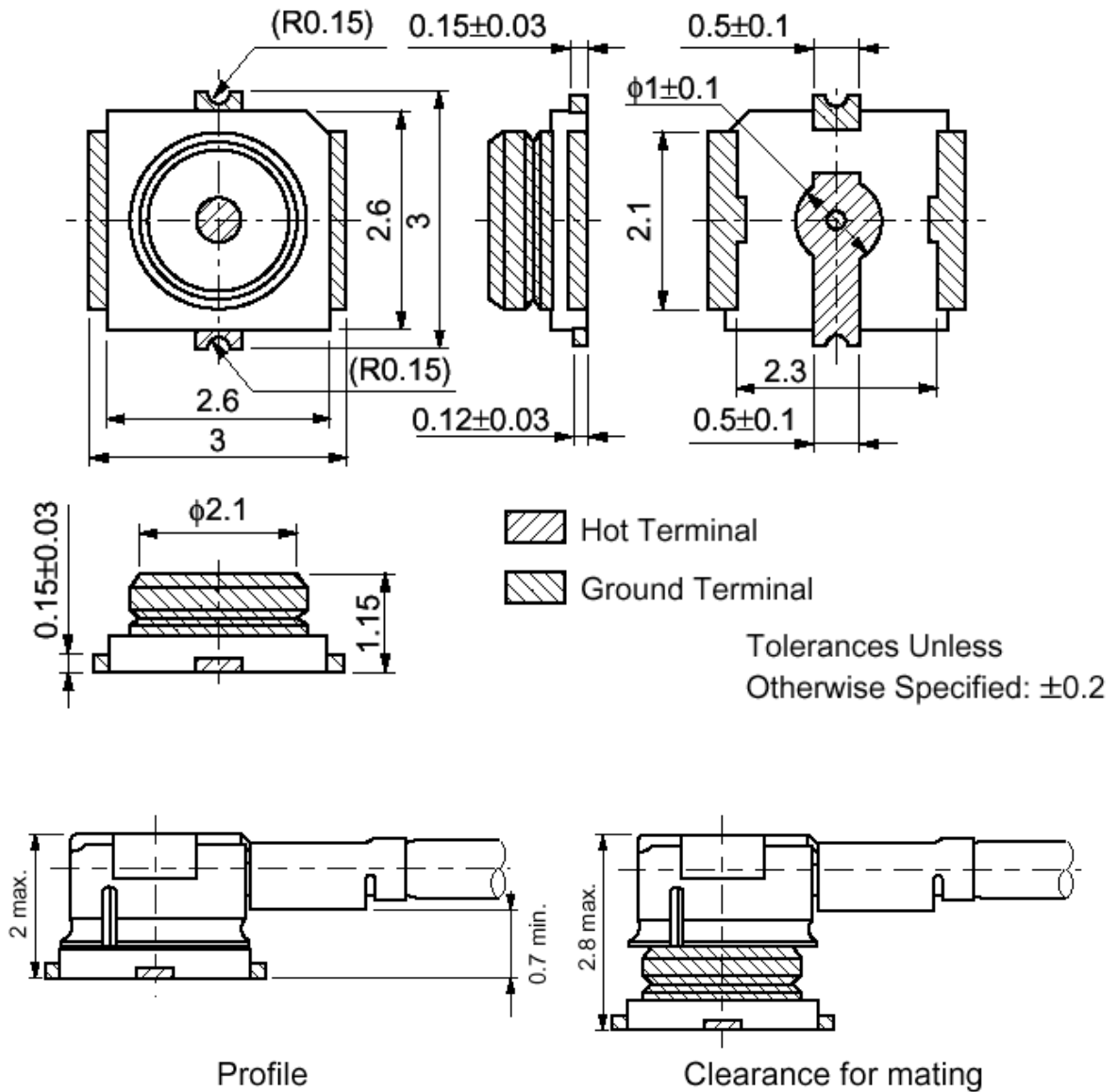

Figure 21: Mechanical dimensions of MuRata GSC connector (in mm)

Table 18: Stress characteristics of the GSC antenna connector

Parameter	Specification
Connector durability	100 cycles of mating and withdrawal with a jig at 12 cycles/minute maximum
Engage force	30N max
Disengage force	3N min, 30N max
Angle of engagement	15 degree max
Mechanical stress to connector	See Table 17 for details
<ul style="list-style-type: none"> Stress to the housing: Stress to outer sleeve: Cable pull strength: 	A and B: 4.9N max. C: 2.94N max and D: 1.96N max E: 4.9N max

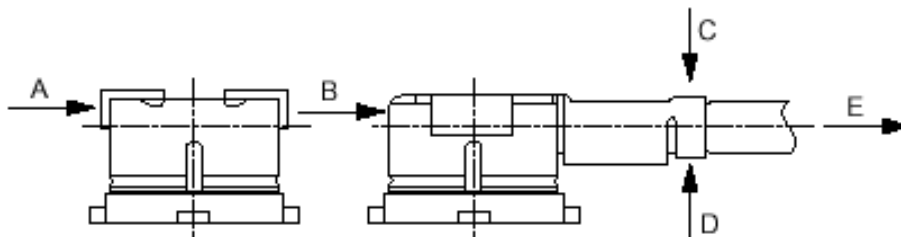

Figure 22: Maximum mechanical stress to the connector

The following figure illustrates the engagement/disengagement tool type P/N M22001 recommended by MuRata and provides instructions for proper use.

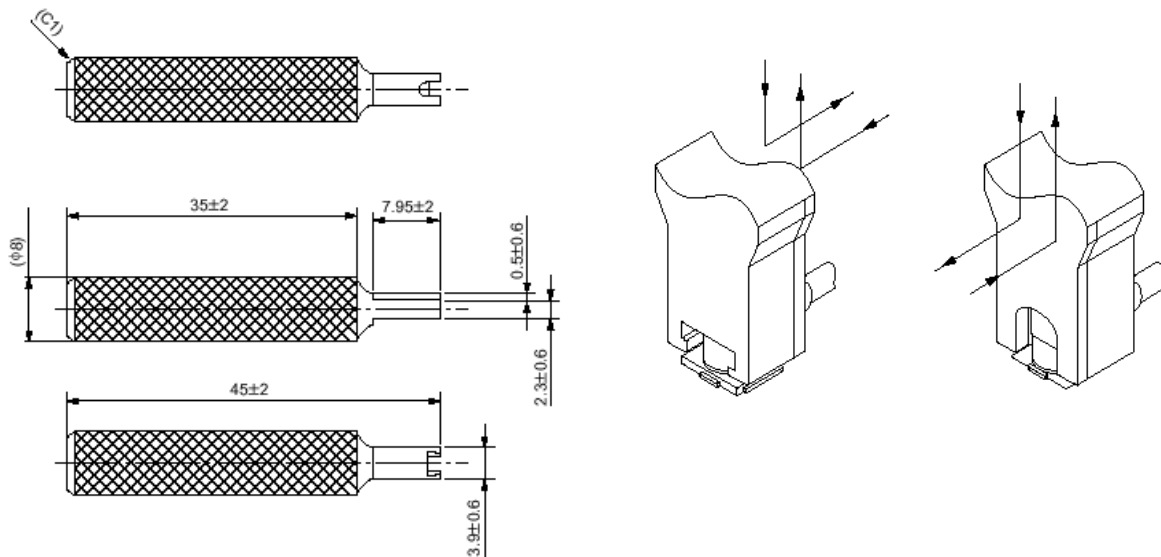

Figure 23: How to use MuRata tool

5 Electrical, reliability and radio characteristics

5.1 Absolute maximum ratings

The absolute maximum ratings stated in Table 19 are stress ratings under non-operating conditions. Stresses beyond any of these limits will cause permanent damage to MC35i.

Table 19: Absolute maximum ratings

Parameter	Min	Max	Unit
Voltage at digital pins	-0.3	3.3	V
Voltage at analog pins	-0.3	3.0	V
Voltage at digital / analog pins in POWER DOWN mode	-0.25	+0.25	V
BATT+	-0.3	4.9	V
Differential load resistance between EPN1 and EPP1	15		Ω
Differential load resistance between EPN2 and EPP1	15		Ω

5.2 Operating conditions

5.2.1 Temperature conditions

Test conditions were specified in accordance with IEC 60068-2 (still air). The values stated below are in compliance with GSM recommendation TS 51.010-1.

Table 20: Operating temperatures

Parameter	Min	Typ	Max	Unit
Ambient temperature (according to GSM 11.10)	-20	25	55	°C
Restricted operation ¹⁾	-25 to -20		55 to 70	°C
Automatic shutdown ²⁾	≤-25		≥70	°C

¹⁾ MC35i operates, but deviations from the GSM specification may occur.

²⁾ Due to temperature measurement uncertainty, a tolerance of ±3°C on these switching thresholds may occur.

5.3 Electrical specifications of the application interface

Please note that the reference voltages listed in Table 21 are the values measured directly on the MC35i module. They do not apply to the accessories connected.

If an input pin is specified for $V_{i,h \max}=3.3V$, ensure never to exceed the stated voltage. The value 3.3V is an absolute maximum rating.

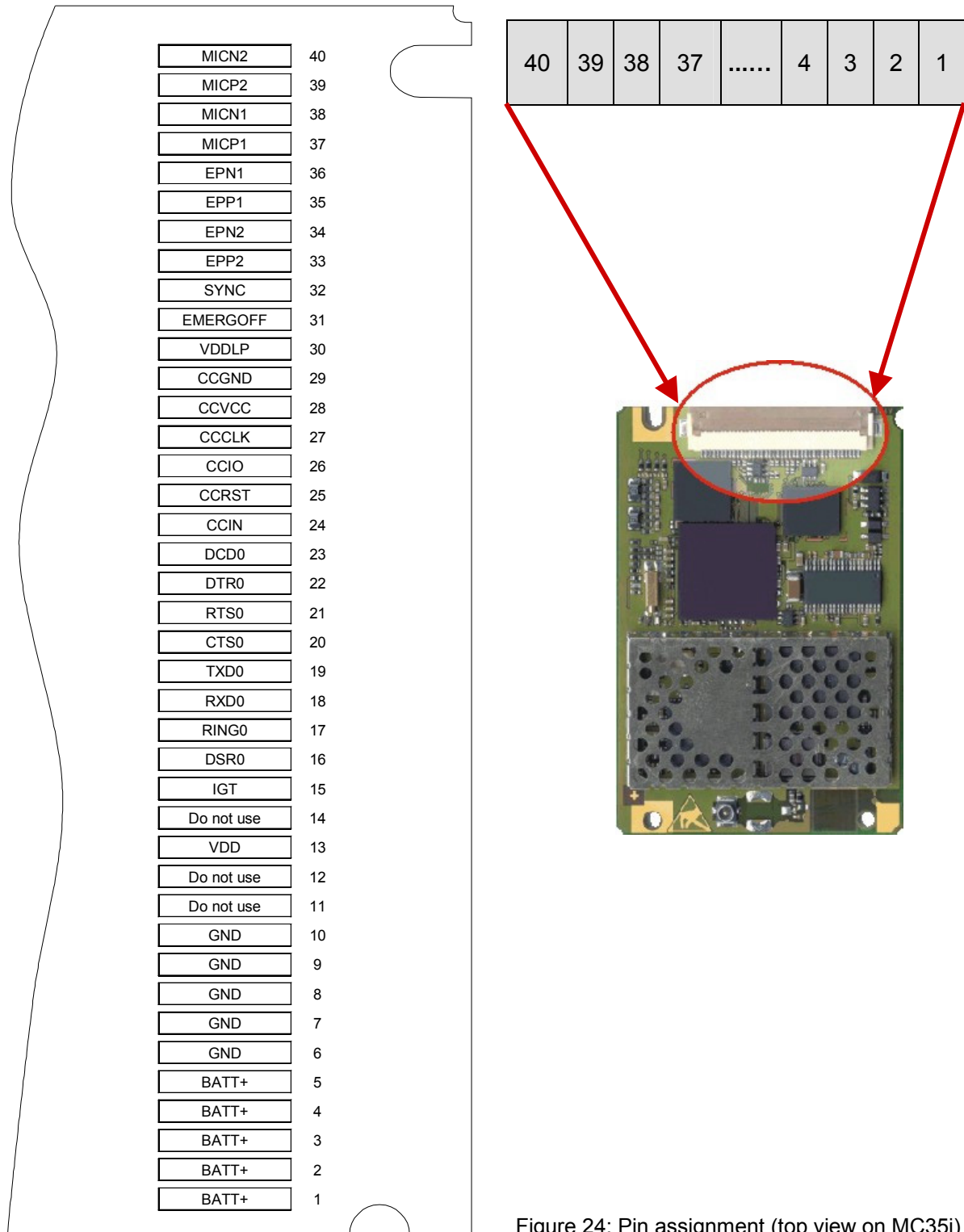

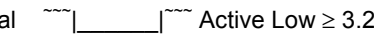
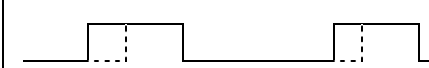

Figure 24: Pin assignment (top view on MC35i)

Table 21: Pin assignment and electrical description of application interface

Function	Signal name	IO	Signal form and level	Comment
Power supply	BATT+	I	$V_I = 3.3V$ to $4.8V$ $V_{I,typ} = 4.2V$ $I_{nom} \approx 2A$, in Burst  1 Tx: Peak current $577\mu s$ every $4.615ms$	Five pins of BATT+ and GND must be connected in parallel for supply purposes because higher peak current may occur, see Chapter 5.4
Power supply	GND		Ground	Application Ground
External supply voltage	VDD	O	IDLE / TALK mode: $V_{out} = 2.9V; \pm 3\% @ 70mA; V_{BATT+} = 4.2V$ and $T_{amb,typ} = 25^\circ C$ $V_{out} = 2.9V; \pm 3\% @ 20mA; V_{BATT+} = 4.8V$ and $T_{amb,typ} = 25^\circ C$ $I_{max} = 70mA$ Power Down mode: $V_{out} = 0V$ $C_{load,max,extern} = 1\mu F$	Can be used, for example, to connect a level converter or a pull-up resistor. Not recommended for components operated by pulse current. Not available in POWER DOWN mode. The external digital logic must not cause any spikes or glitches on voltage VDD. VDD signals "ON" state of module. Voltage is applied ca. 60ms after IGT was driven low If unused keep pin open.
Ignition	/IGT	I	$R_I \approx 100k\Omega, C_I \approx 1nF$ $V_{IL,max} = 0.5V$ at $I_{max} = -20\mu A$ $V_{Open,max} = 2.3V$ ON  Active Low $\geq 100ms$	This signal switches the mobile ON. This line must be driven low by an Open Drain or Open Collector driver.
Emergency shutdown	/EMERGOFF	I	$R_I \approx 22k\Omega$ $V_{IL,max} = 0.45V$ at $I_{max} = -100\mu A$ $V_{Open,max} = 2.25V$ Signal  Active Low $\geq 3.2s$ Watchdog: $V_{OL,max} = 0.35V$ at $I = 10\mu A$ $V_{OH,min} = 2.25V$ at $I = -10\mu A$ $f_{Omin} = 0.16Hz$ $f_{Omax} = 1.55Hz$	This line must be driven by an Open Drain or Open Collector driver. Emergency shutdown deactivates the modules power supply. A reset can be done with a following IGT. /EMERGOFF also indicates the internal watchdog function. To avoid floating if pin is high impedance, use pull-down resistor tied to GND. See chapter 3.3.2.1 If unused keep pin open.

Function	Signal name	IO	Signal form and level	Comment
Synchroni- zation	SYNC	O	$V_{OLmax} = 0.3V$ at $I = 0.1mA$ $V_{OHmin} = 2.25V$ at $I = -0.1mA$ $V_{OHmax} = 2.73V$  1 Tx: 877µs impulse each 4.615ms and	Indication of increased current consumption during uplink transmission burst, however, the timing is different during handover. Alternatively used to control status LED. If unused keep pin open.
SIM Interface	CCIN	I	$R_i \approx 100k\Omega$ $V_{ILmax} = 0.5V$ $V_{IHmin} = 2.15V$ at $I = 20\mu A$, $V_{IHmax} = 3.3V$ at $I = 30\mu A$	CCIN = high, SIM card holder closed (no card recognition) Maximum cable length or copper track 200mm to SIM card holder. All signals of SIM interface are protected against ESD with a special diode array. Usage of CCGND is mandatory.
	CCRST	O	$R_o \approx 47\Omega$ $V_{OLmax} = 0.25V$ at $I = 1mA$ $V_{OHmin} = 2.3V$ at $I = -1mA$ $V_{OHmax} = 2.73V$	
	CCIO	IO	$R_i \approx 10k\Omega$ $V_{ILmax} = 0.5V$ $V_{IHmin} = 1.95V$, $V_{IHmax} = 3.3V$ $R_o \approx 220\Omega$ $V_{OLmax} = 0.4V$ at $I = 1mA$ $V_{OHmin} = 2.15V$ at $I = -1mA$ $V_{OHmin} = 2.55V$ at $I = -20\mu A$ $V_{OHmax} = 2.96V$	
	CCCLK	O	$R_o \approx 220\Omega$ $V_{OLmax} = 0.4V$ at $I = 1mA$ $V_{OHmin} = 2.15V$ at $I = -1mA$ $V_{OHmax} = 2.73V$	
	CCVCC	O	$R_{Omax} = 5\Omega$ $CCVCCmin = 2.84V$, $CCVCCmax = 2.96V$ $I_{max} = 20mA$	
	CCGND		Ground	
RTC backup	VDDL	I/O	IDLE / TALK / DATA / Power down mode if BATT+ connected: $V_{out} < V_{BATT+}$ is disconnected $R_i = 1k\Omega$ (serial resistor) Power Down mode if BATT+ disconnected $V_{in} = 2.0V \dots 5.5V$ $I_{in,max} = 30 \mu A$	If unused, keep pin open.
Serial interface	/RXD0	O	$V_{OLmax} = 0.3V$ @ $I = 0.1mA$ $V_{OHmin} = 2.25V$ @ $I = -0.1mA$ $V_{OHmax} = 2.73V$	Serial interface for AT Commands or data stream. To avoid floating if pin is high impedance, use pull-down resistor tied to GND. See chapter 3.3.2.1 If lines are unused keep pins open.
	/TXD0	I		
	/CTS0	O		
	/RTS0	I	$V_{IHmin} = 1.95V$, $V_{IHmax} = 3.45V$	
	/DTR0	I		
	/DCD0	O	$/RTS0, /DTR0: I_{max} = -90\mu A$ @ $V_{IN} = 0V$	
	/DSR0	O		
	/RING0	O	$/TXD0: I_{max} = -30\mu A$ @ $V_{IN} = 0V$ $V_{IL} = 0.25V$	

Function	Signal name	IO	Signal form and level	Comment	
Analog Audio interface	EPP2	O	$R_i \approx 15\Omega$, (30k Ω if not active) gain range -18...0dB in 6 dB steps Max. output differential DC offset 100mV $V_{Out} = 3.7V_{pp}$ typical, $V_{Out} = 4.07V_{pp}$ max, $V_{Out} = 3.03V_{pp}$ min, measurement conditions: sine signal, 3.14 dBm0, 1024Hz, load resistance = 200k Ω audio mode = 5, outBbcGain = 0, outCalibrate = 16384	The audio output is balanced and can directly operate an earpiece. If unused keep pins open.	
	EPN2	O			
	EPP1	O	$R_i \approx 15\Omega$, (30k Ω if not active) gain range -18...0dB in 6 dB steps Max. output differential DC offset 100mV $V_{Out} = 3.7V_{pp}$ typical, $V_{Out} = 4.07V_{pp}$ max, $V_{Out} = 3.03V_{pp}$ min, @ measurement conditions: sine signal, 3.14 dBm0, 1024Hz, load resistance = 200k Ω audio mode = 6, outBbcGain = 0, outCalibrate = 16384		The audio output is balanced and can directly operate an earpiece. If unused keep pins open. Short circuit may damage the outputs
	EPN1	O			
	MICP1	I	$R_i = 2k\Omega$ differential $V_{I,max} = 1.03V_{pp}$ $V_{supply} = 2.65V$ at $R_{supply} = 4k\Omega$ analog amplification range = 0...42dB in 6dB steps		This microphone input is balanced and can feed an active microphone. If unused keep pins open.
	MICN1	I			
	MICP2	I	$R_i = 2k\Omega$ differential $V_{I,max} = 1.03V_{pp}$ $V_{supply} = 2.65V$ at $R_{supply} = 4k\Omega$ analog amplification range = 0...42dB in 6dB steps		This microphone input is balanced and can feed an active microphone. If unused keep pins open.
	MICN2	I			

Explanation of signal names:
 P = positive, N = negative

5.4 Power supply ratings

Table 22: Power supply ratings

Parameter	Description	Conditions	Min	Typ	Max	Unit
V _{BATT+}	Supply voltage	Directly measured at the reference point BATT+ pad (see Figure 29) Voltage must stay within the min/max values, including voltage drop, ripple, spikes.	3.3 ⁵⁾	4.2	4.8	V
	Voltage drop during transmit burst ¹⁾	Normal condition, power control level for P _{out max}			400	mV
	Voltage ripple ¹⁾	Normal condition, power control level for P _{out max} @ f<200kHz @ f>200kHz			50 2	mV
I _{BATT+}	Average supply current ⁴⁾	Power Down mode		50	100	μA
		SLEEP mode @ DRX=6		3		mA
		IDLE mode EGSM 900 ¹⁾ GSM 1800 ²⁾		25		mA
		TALK mode EGSM 900 ¹⁾ GSM 1800		300 ⁶⁾ 270 ⁶⁾	450	mA
	IDLE mode GPRS EGSM 900 ¹⁾ GSM 1800 ²⁾		25			
	DATA mode GPRS Multislot class 8 EGSM 900 ¹⁾ GSM 1800 ²⁾		360 ⁶⁾ 330 ⁶⁾	540	mA	
	Peak supply current (during 577μs transmission slot every 4.6ms)	Power level PCL 5		2		3.5 ³⁾

¹⁾ Power control level PCL 5

²⁾ Power control level PCL 0

³⁾ The maximum current at the BATT+ line during transmit operation strongly depends on the antenna performance. See Figure 25 for details.

⁴⁾ All average supply current values @ I_{VDD} = 0mA.

⁵⁾ During transmit bursts, the voltage at the BATT+ reference point may drop to min. 3.3V (due to the source resistance of the supply voltage and cable losses). Note that this minimum voltage must be measured against the GND reference point on MC35i. See Chapter 3.2.2.

⁶⁾ Stated value applies to an average antenna performance.

5.4.1 Peak current during transmit burst

A Smith chart shows the complex impedance plane. The Smith chart in Figure 25 illustrates the typical dependence between the peak current consumption of the application during a transmit burst and an impedance connected to the antenna jack / GSC connector.

As can be seen, the peak current consumption at 50Ω antenna load is about 1.7 A, but it can vary due to antenna mismatch and reflection. Maximum output power, of course, is achieved with an antenna impedance of 50Ω.

Figure 25 shows the current consumption at the following conditions:

- Channel with the highest current consumption: 881MHz (Channel 979)
- $T_{amb} = 25^{\circ}\text{C}$
- Low supply voltage during transmit burst $V_{BATT+} = >3.3\text{V}$ (measuring results at high voltage conditions at $V_{BATT+} = <4.6\text{V}$ are almost identical)

The measurement case was performed with a total resistance of about 100mΩ in the current path.

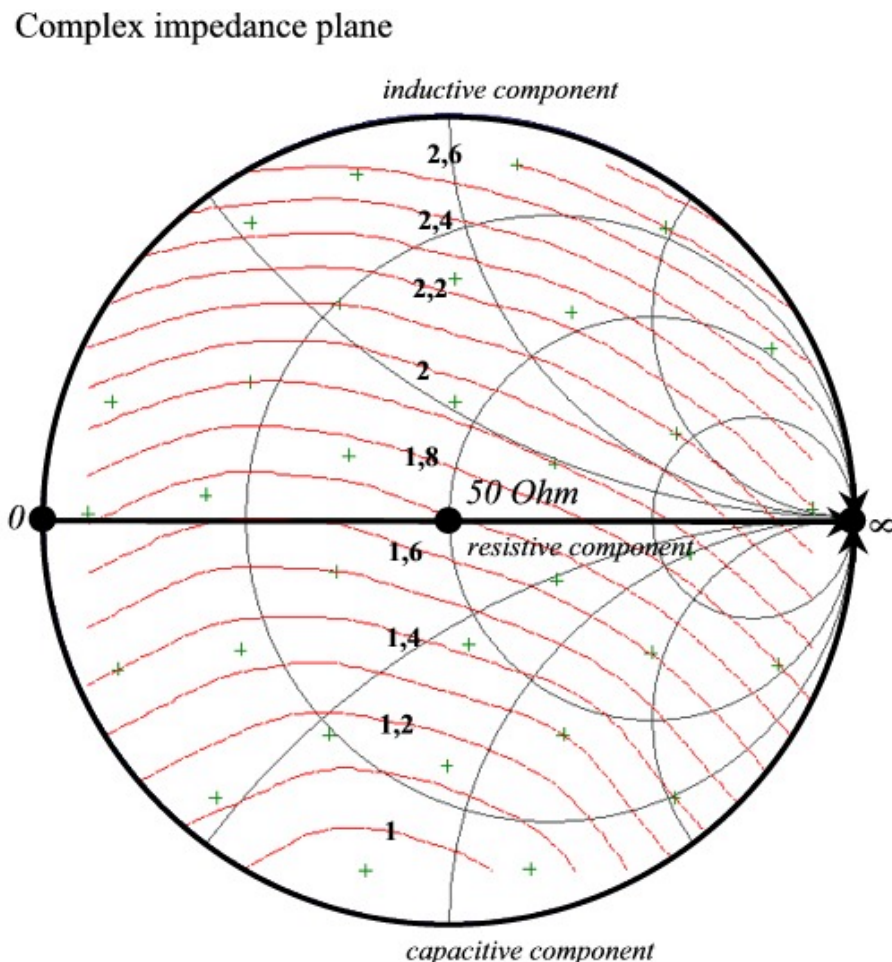

Figure 25: Peak current (in A) during transmit burst vs. antenna impedance

5.5 Electrical characteristics of the voiceband part

5.5.1 Setting audio parameters by AT command

The audio modes 2 and 6 can be adjusted according to the parameters listed below. Each audio mode is assigned a separate set of parameters.

Table 23: Audio parameters adjustable by AT command

Parameter	Influence to	Range	Gain range	Calculation
inBbcGain	MICP/MICN analogue amplifier gain of baseband controller before ADC	0...7	0...42dB	6dB steps
inCalibrate	Digital attenuation of input signal after ADC	0...32767	-∞...0dB	$20 * \log(\text{inCalibrate}/32768)$
outBbcGain	EPP/EPN analog output gain of baseband controller after DAC	0...3	0...-18dB	6dB steps
outCalibrate[n] n = 0...4	Digital attenuation of output signal after speech decoder, before summation of sidetone and DAC Present for each volume step[n]	0...32767	-∞...+6dB	$20 * \log(2 * \text{outCalibrate}[n]/32768)$
sideTone	Digital attenuation of sidetone Is corrected internally by outBbcGain to obtain a constant sidetone independent of output volume	0...32767	-∞...0dB	$20 * \log(\text{sideTone}/32768)$

Note: The parameters inCalibrate, outCalibrate and sideTone accept also values from 32768 to 65535. These values are internally truncated to 32767.

5.5.2 Audio programming model

The audio programming model shows how the signal path can be influenced by varying the AT command parameters. The parameters `inBbcGain` and `inCalibrate` can be set with `AT^SNFI`. All the other parameters are adjustable with `AT^SNFO`.

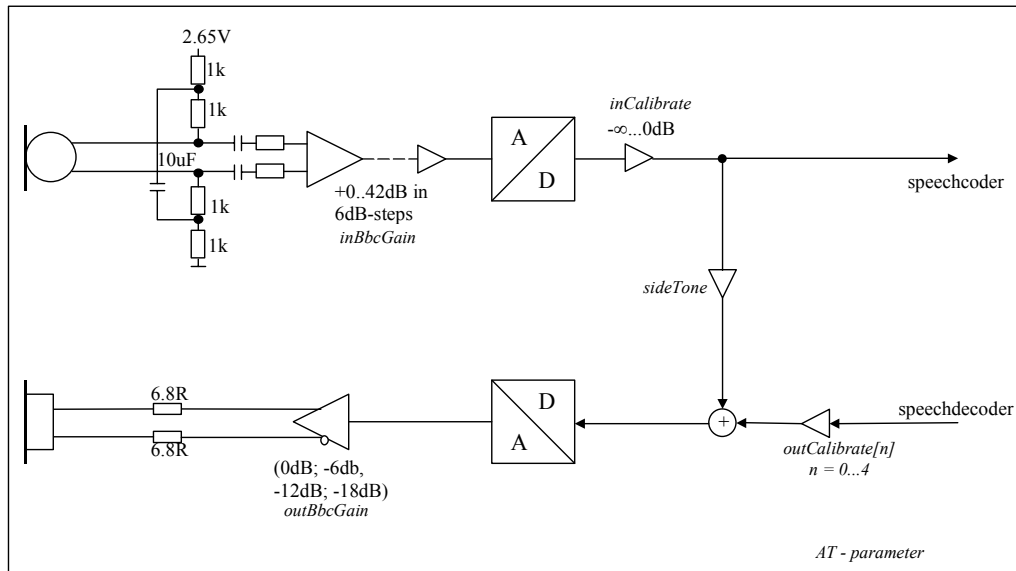

Figure 26: AT audio programming model

5.5.3 Characteristics of audio modes

The electrical characteristics of the voiceband part depend on the current audio mode set with the AT[^]SNFS command.

Table 24: Voiceband characteristics (typical)

Audio mode no. AT [^] SNFS=	1 (Default settings, not adjustable)	2	3	4	5	6
Name	Default Handset	Basic Handsfree	Headset	User Handset	Plain Codec 1	Plain Codec 2
Purpose	DSB with Votronic handset	Siemens Car Kit Portable	Siemens Headset	DSB with individual handset	Direct access to speech coder	Direct access to speech coder
Gain setting via AT command. Defaults:	Fix	Adjustable	Adjustable	Adjustable	Adjustable	Adjustable
inBbcGain	5 (30dB)	2 (12dB)	5 (30dB)	5 (30dB)	0 (0dB)	0 (0dB)
outBbcGain	1 (-6dB)	1 (-6dB)	2 (-12dB)	1 (-6dB)	0 (0dB)	0 (0dB)
MICPn/MICNn EPPn/EPNn	n=1	n=2	n=2	n=1	n=1	n=2 ⁴⁾
Power supply	ON	ON	ON	ON	OFF	OFF
Sidetone	ON	---	Adjustable	Adjustable	Adjustable	Adjustable
Volume control	OFF	Adjustable	Adjustable	Adjustable	Adjustable	Adjustable
Limiter (receive)	ON	ON	ON	ON	---	---
Compressor (receive)	---	OFF ¹⁾	---	---	---	---
AGC (send)	OFF	---	ON	---	---	---
Echo control (send)	Suppression	Cancellation + suppression	---	Suppression	---	---
Noise suppression ²⁾	---	up to 10dB	10dB	---	---	---
MIC input signal for 0dBm0 @ 1024 Hz (default gain)	12.5mV	48mV	11mV @ -3dBm0 due to AGC	12.5mV	315mV	315mV
EP output signal in mV rms. @ 0dBm0, 1024 Hz, no load (default gain); @ 3.14 dBm0	275mV	120 mV default @ max volume	270mV default @ max volume	275 mV default @ max volume	895mV 3.7 Vpp	895mV 3.7 Vpp
Sidetone gain at default settings between MIC and EP	27.7dB	-∞ dB	Affected by AGC, 9.3dB @ 11mV (MIC)	27.7 dB	-2.7dB @ sideTone = 8192 ³⁾	-2.7dB @ sideTone = 8192 ³⁾

¹⁾ Adaptive, receive volume increases with higher ambient noise level. The compressor can be activated by loading an application specific audio parameter set (see [9])

²⁾ In audio modes with noise reduction, the microphone input signal for 0dBm0 shall be measured with a sine burst signal for the tone duration of 5 seconds and a pause of 2 sec. The sine signal appears as noise and, after approx. 12 sec, is attenuated by the noise reduction by up to 10dB.

³⁾ See AT[^]SNFO command in [1].

⁴⁾ Audio mode 5 and 6 are identical. With AT[^]SAIC, you can easily switch mode 5 to the second interface. Therefore, audio mode 6 is only kept for compatibility to earlier GSM products.

Note: With regard to acoustic shock, the cellular application must be designed to avoid sending false AT commands that might increase amplification, e.g. for a high sensitive earpiece. A protection circuit should be implemented in the cellular application.

5.5.4 Voiceband receive path

The values specified below were tested to 1kHz and 0dB gain stage, unless otherwise stated.

gs = 0dB means audio mode = 5 for EPP1 to EPN1 and 6 for EPP2 to EPN2, inBbcGain= 0, inCalibrate = 32767, outBbcGain = 0, OutCalibrate = 16384, sideTone = 0.

Table 25: Voiceband receive path

Parameter	Min	Typ	Max	Unit	Test condition / remark
Differential output voltage (peak to peak)	3.33	3.7	4.07	V	from EPPx to EPNx gs = 0dB @ 3.14 dBm0
Differential output gain settings (gs) at 6dB stages (outBbcGain)	-18		0	dB	
fine scaling by DSP (outCalibrate)	-∞		0	dB	
Output differential DC offset			100	mV	gs = 0dB, outBbcGain = 0 and -6dB
Differential output resistance	13	15		Ω	from EPPx to EPNx
Absolute gain accuracy			0.8	dB	Variation due to change in VDD, temperature and life time
Attenuation distortion			1	dB	for 300...3900Hz, @ EPPx/EPNx (333Hz) / @ EPPx/EPNx (3.66kHz)
Out-of-band discrimination	60			dB	for $f > 4$ kHz with in-band test signal @ 1kHz and 1kHz RBW

gs = gain setting

5.5.5 Voiceband transmit path

The values specified below were tested to 1kHz and 0dB gain stage, unless otherwise stated.

Audio mode = 5 for MICP1 to MICN1 and 6 for MICP2 to MICN2, inBbcGain= 0, inCalibrate = 32767, outBbcGain = 0, OutCalibrate = 16384, sideTone = 0

Table 26: Voiceband transmit path

Parameter	Min	Typ	Max	Unit	Test condition/Remark
Input voltage (peak to peak) MICP1 to MICN1, MICP2 to MICN2			1.03	V	
Input amplifier gain in 6dB steps (inBbcGain)	0		42	dB	
fine scaling by DSP (inCalibrate)	-∞		0	dB	
Input impedance		2.0		kΩ	
Microphone supply voltage ON Ri = 4kΩ	2.57 2.17 1.77	2.65 2.25 1.85	2.73 2.33 1.93	V V V	no supply current @ 100μA @ 200μA
Microphone supply voltage OFF Ri = 4kΩ		0		V	
Microphone supply in power down mode					see Figure 27

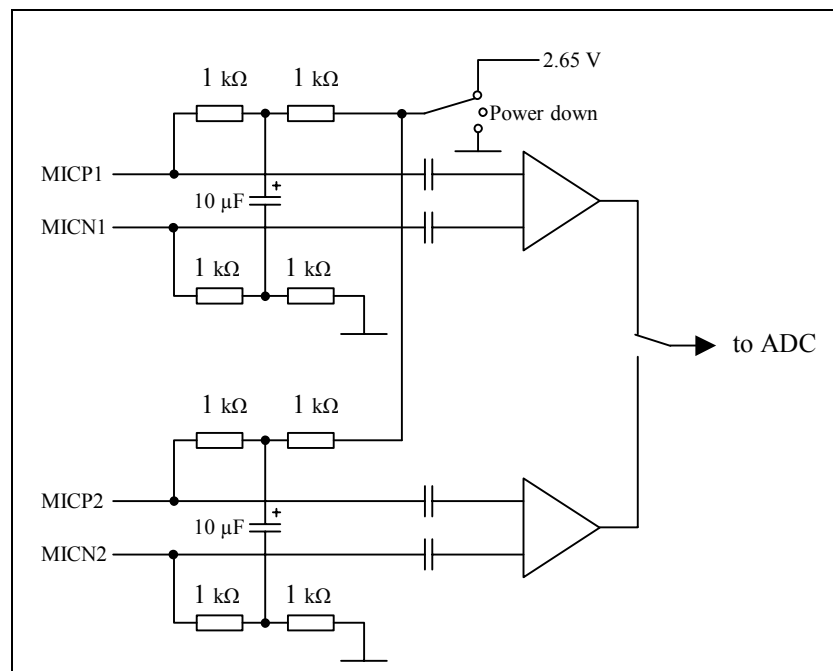

Figure 27: Structure of audio inputs

5.6 Air interface

Table 27: Air interface

Parameter		Min	Typ ³⁾	Max	Unit
Frequency range Uplink (MS → BTS)	E-GSM 900	880		915	MHz
	GSM 1800	1710		1785	MHz
Frequency range Downlink (BTS → MS)	E-GSM 900	925		960	MHz
	GSM 1800	1805		1880	MHz
RF power @ ARP with 50Ω load	E-GSM 900 ¹⁾	31	32.5		dBm
	GSM 1800 ²⁾	28	29.5		dBm
Number of carriers	E-GSM 900		174		
	GSM 1800		374		
Duplex spacing	E-GSM 900		45		MHz
	GSM 1800		95		MHz
Carrier spacing			200		kHz
Multiplex, Duplex	TDMA / FDMA, FDD				
Time slots per TDMA frame			8		
Frame duration			4.615		ms
Time slot duration			577		μs
Modulation	GMSK				
Receiver input sensitivity @ ARP Under all propagation conditions according to GSM specification	E-GSM 900	-102			dBm
	GSM 1800	-102			dBm
Receiver input sensitivity @ ARP BER Class II < 2.4%	E-GSM 900		-107		dBm
	GSM 1800		-106		dBm

¹⁾ Power control level 5

²⁾ Power control level 0

³⁾ At 50Ω load impedance. The output power depends on the BATT+ voltage during transmit bursts and the measured board temperature. The given values are valid for room temperature and nominal operating voltage.

Table 28: Local oscillator and intermediate frequencies used by MC35i

All frequencies in MHz		Frequency Band	Local Oscillator	Intermediate Frequency
E-GSM 900	TX	880 - 915	1470 - 1550	90 - 115
	RX	925 - 960	1385 - 1440	0
GSM 1800	TX	1710 - 1785	1350 - 1415	90 - 115
	RX	1805 - 1880	1350 - 1415	0

5.7 Electrostatic discharge

The GSM engine is not protected against Electrostatic Discharge (ESD) in general. Consequently, it is subject to ESD handling precautions that typically apply to ESD sensitive components. Proper ESD handling and packaging procedures must be applied throughout the processing, handling and operation of any application that incorporates a MC35i module.

Despite of this, the antenna port, the SIM interface and the POWER port are equipped with spark gaps and clamp diodes to protect these lines from overvoltage. For all the other ports, EDS protection must be implemented on the application platform that incorporates the GSM engine.

MC35i has been tested according to the EN 61000-4-2 directive. The measured values verified for the Siemens reference configuration can be gathered from the following table.

Table 29: Measured electrostatic values

Specification / Requirements	Contact discharge	Air discharge
ETSI EN 301 489-7		
ESD at SIM port	± 4kV	± 8kV
ESD at antenna port	± 4kV	± 8kV
ESD at power pins BATT+, GND	± 4kV	± 8kV
Human Body Model – IEC / PAS 62179 (test conditions: 1.5 kΩ, 100 pF)		
ESD at the module	± 1kV	

Please note that the values may vary with the individual application design. For example, it matters whether or not the application platform is grounded over external devices like a computer or other equipment, such as the Siemens reference application described in Chapter 7.

5.8 Reliability characteristics

The test conditions stated below are an extract of the complete test specifications.

Table 30: Summary of reliability test conditions

Type of test	Conditions	Standard
Vibration	Frequency range: 10-20 Hz; acceleration: 3.1mm amplitude Frequency range: 20-500 Hz; acceleration: 5g Duration: 2h per axis = 10 cycles; 3 axes	DIN IEC 68-2-6
Shock half-sinus	Acceleration: 500g Shock duration: 1msec 1 shock per axis 6 positions (\pm x, y and z)	DIN IEC 68-2-27
Dry heat	Temperature: $+70 \pm 2^{\circ}\text{C}$ Test duration: 16 h Humidity in the test chamber: < 50%	EN 60068-2-2 Bb ETS 300019-2-7
Temperature change (shock)	Low temperature: $-40^{\circ}\text{C} \pm 2^{\circ}\text{C}$ High temperature: $+85^{\circ}\text{C} \pm 2^{\circ}\text{C}$ Changeover time: < 30s (dual chamber system) Test duration: 1 h Number of repetitions: 100	DIN IEC 68-2-14 Na ETS 300019-2-7
Damp heat cyclic	High temperature: $+55^{\circ}\text{C} \pm 2^{\circ}\text{C}$ Low temperature: $+25^{\circ}\text{C} \pm 2^{\circ}\text{C}$ Humidity: 93% \pm 3% Number of repetitions: 6 Test duration: 12h + 12h	DIN IEC 68-2-30 Db ETS 300019-2-5
Cold (constant exposure)	Temperature: $-40 \pm 2^{\circ}\text{C}$ Test duration: 16 h	DIN IEC 68-2-1

6 Mechanics

6.1 Mechanical dimensions of MC35i

Figure 28 shows the RF part of MC35i and provides an overview of the board's mechanical dimensions. For further details see Figure 29.

Size: $54.5 \pm 0.2 \times 36 \pm 0.2 \times 3.55 \pm 0.3$ mm (height of antenna connector not considered)
Weight: 9g

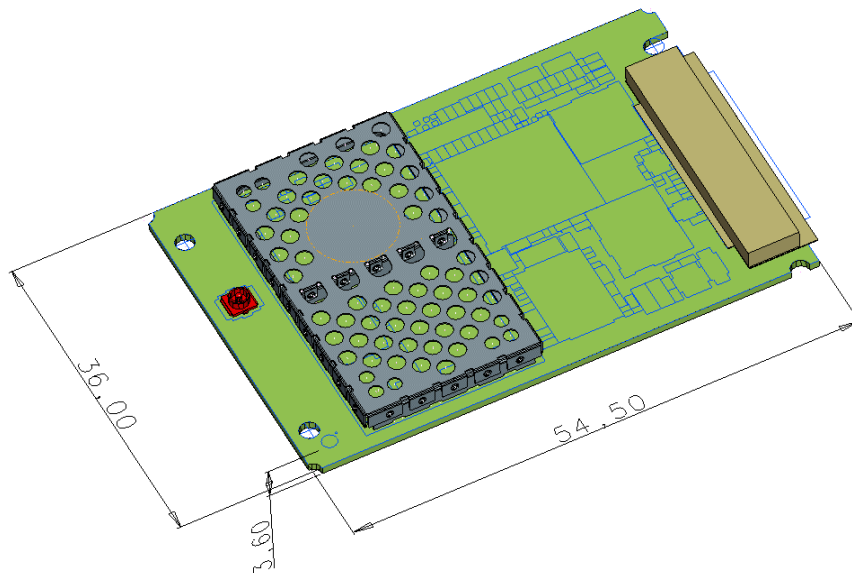
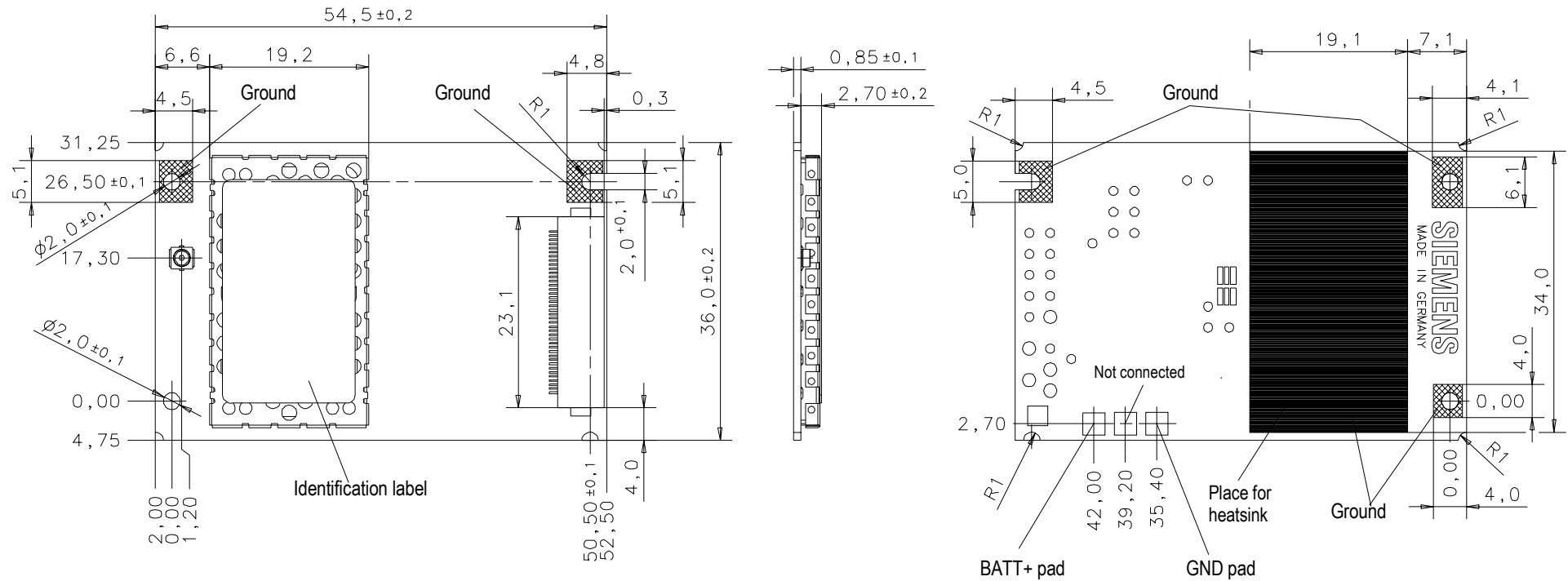

Figure 28: MC35i – top view



All dimensions in millimeter

Figure 29: Mechanical dimensions of MC35i

6.2 Mounting MC35i onto the application platform

For the cellular application to operate reliably it is essential that the GSM engine is securely attached to the host housing.

The MC35i board provides three mounting holes. To properly mount it to the host device you can use M1.6 or M1.8 screws plus suitable washers. The maximum diameter of the screw head incl. the washer must not exceed 4 mm.

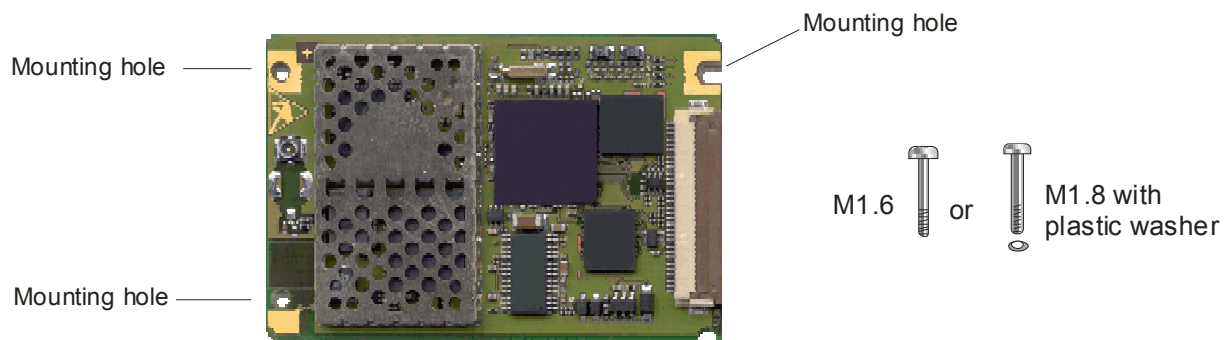

Figure 30: Recommended screws

Avoid placing the MC35i board tightly to the host device. Instead, it is recommended to set spacers between the module and the host device. If your design approach does not allow for spacers make sure the host device provides an opening for the RF part.

To prevent mechanical damage, be careful not to force, bend or twist the GSM engine. Be sure it is positioned flat against the host device. Avoid exerting pressure on the shielding cover to prevent degradation of shielding performance.

6.3 ZIF connector (application interface)

This chapter provides specifications for the 40-pin ZIF connector which serves as physical interface to the host application. The connector assembled on the MC35i PCB is type Hirose FH12-40S 0.5 SH.

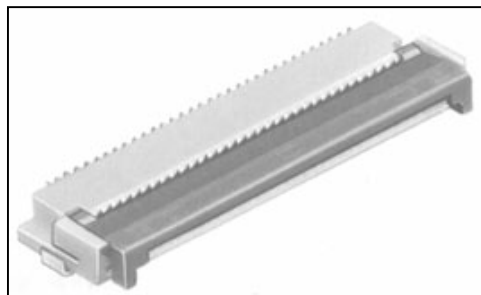

Figure 31: Hirose FH12 connector

The ZIF (zero insertion force) design allows to easily fasten or remove the cable without the need for special tools. Simply insert the FFC into the open socket without using any pressure. Then carefully close the socket lid until the contacts of the socket grip the cable contacts.

Table 31: Ordering information

Item	Part number	Pitch (mm)	HRS number
ZIF connector	FH12-40S 0.5 SH	0.5	CL586-0527-7

Table 32: Electrical and mechanical characteristics of Hirose FH12-40S 0.5 SH connector

Parameter	Specification (40 pin ZIF connector)
Number of Contacts	40
Quantity delivered	2000 Connectors per Tape & Reel
Voltage	50V
Current Rating	0.4A max per contact
Resistance	0.05Ω per contact
Dielectric Withstanding Voltage	150V RMS AC for 1min
Operating Temperature	-40°C...+85°C
Contact Material	phosphor bronze finish: solder plating
Insulator Material	PPS, deep brown / Polyamide, beige
FFC/FPC Thickness	0.3mm ±0.05mm (0.012" ±0.002")
Maximum connection cycles	20 (@ 50mΩ max)
Cable	FFC (Flat Flexible Cable), max. length 200mm from SIM interface (see Chapter 6.3.1)

6.3.1 FFC

As stated in Chapter 3.8 the total cable length between the ZIF connector pins on MC35i and the pins of the SIM card holder must not exceed 200 mm in order to meet the specifications of 3GPP TS 51.010-1 and to satisfy the requirements of EMC compliance.

6.3.2 Mechanical dimensions of Hirose FH12-40S 0.5 SH connector

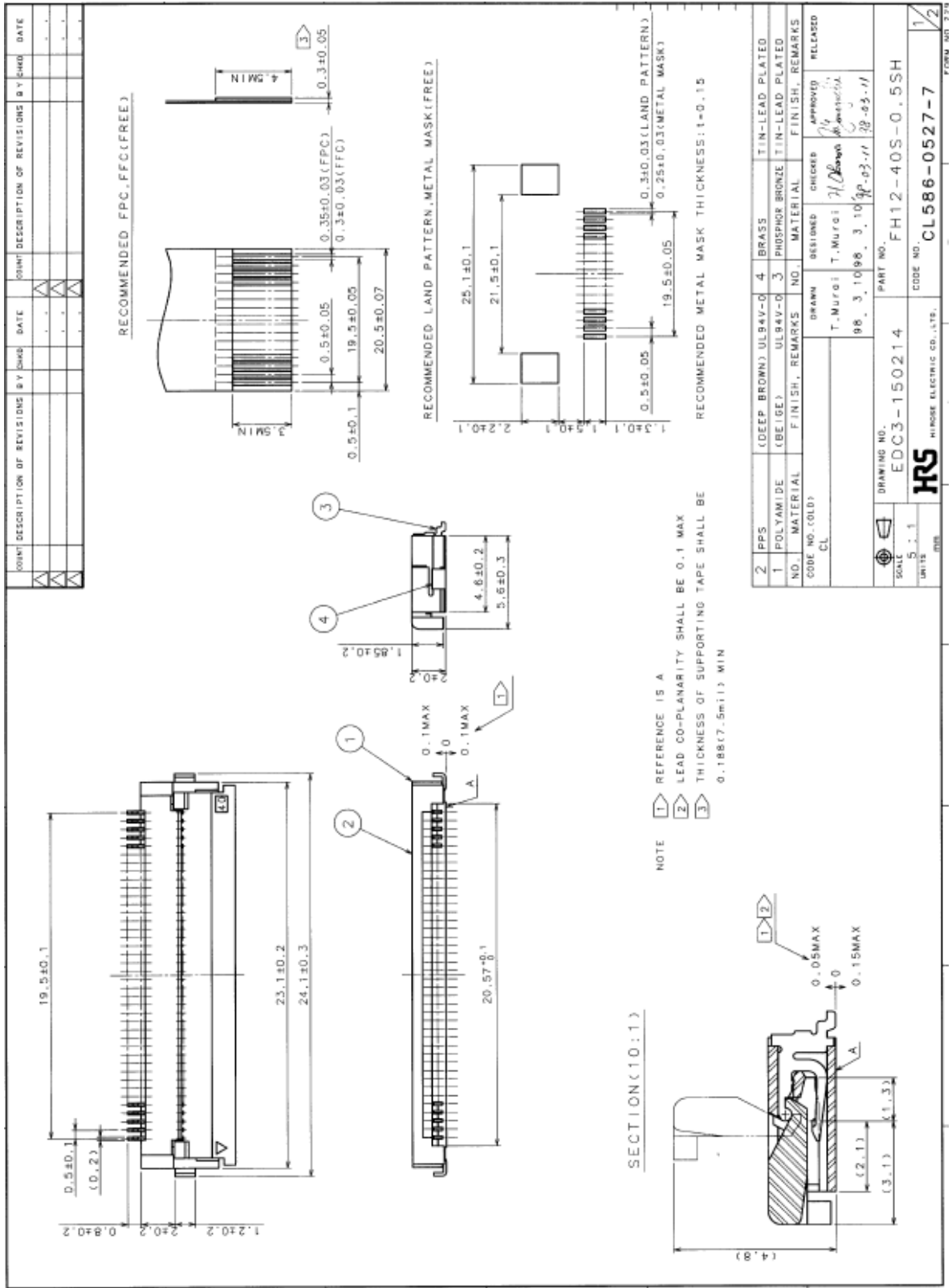

Figure 32: Description of Hirose FH12 connector

7 Reference approval

7.1 Reference equipment

The Siemens reference setup submitted to type approve MC35i consists of the following components:

- Siemens MC35i cellular engine
- Development Support Box (DSB35)
- FFC from ZIF connector on MC35i to application interface on DSB35.
- SIM card holder integrated on the DSB35
- Handset type Votronic HH-SI-30.3/V1.1/0
- PC as MMI

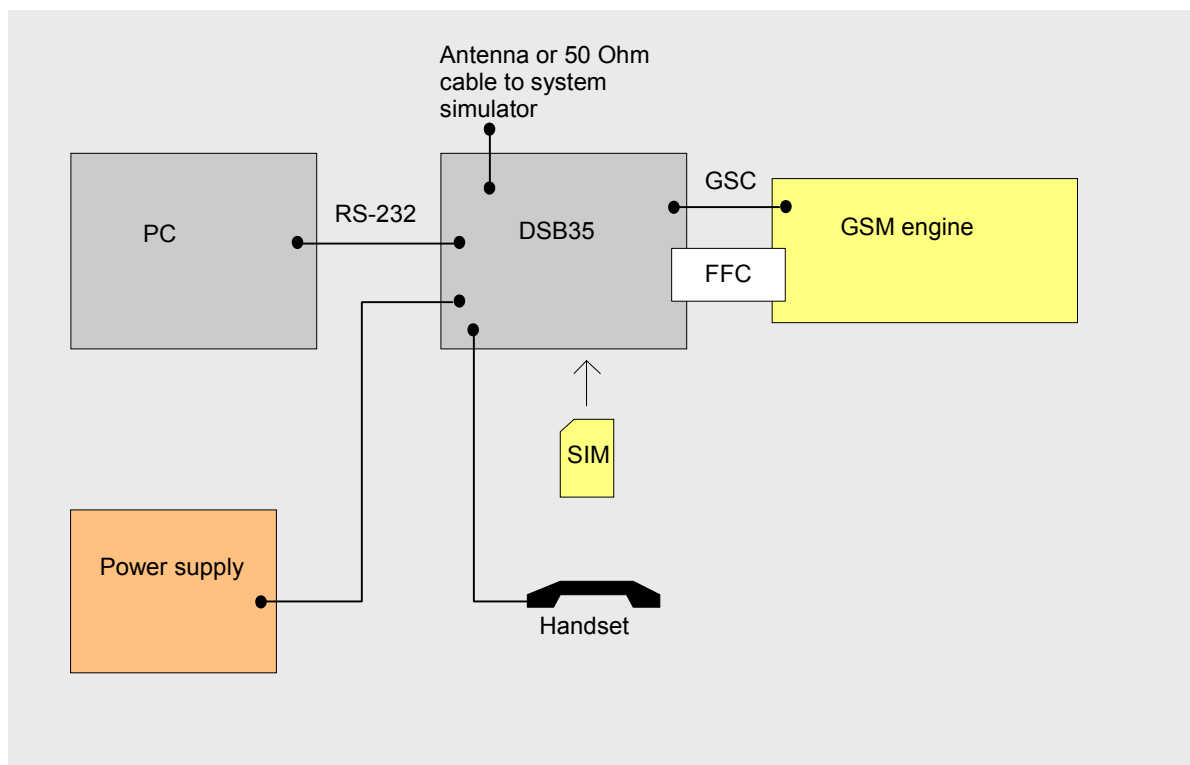

Figure 33: Reference equipment for approval

8 APPENDIX: List of parts and recommended accessories

Table 33: List of accessories

Description	Supplier	Ordering information
MC35i engine	Siemens	Siemens ordering number L36880-N8530-A100
SIM card holder incl. push button ejector and slide-in tray	Molex	Ordering numbers: 91228 91236 Molex Deutschland GmbH Felix-Wankel-Str. 11 74078 Heilbronn-Biberach, Germany Phone: +49-(0)7066-9555 0 Fax: +49-(0)7066-9555 29 Email: mxgermany@molex.com Web site: http://www.molex.com/ American Headquarters Lisle, Illinois 60532 U.S.A. Phone: +1-800-78MOLEX Fax: +1-630-969-1352 Far East Headquarters Yamato, Kanagawa, Japan Phone: +81-462-65-2324 Fax: +81-462 Far East Headquarters Jurong, Singapore Phone: +65-268-6868 Fax: +65-265-6044
ZIF connector	Hirose	See Chapter 6.3 for specifications of FH12-40S 0.5 SH connector and mating cables http://www.hirose.com
Flat cable for ZIF connector cable 160 mm cable 80 mm	Axon	Ordering numbers: FFC 0.50 A 40 / 0160 K4.0-4.0-08.0-08.0SABB FFC 0.50 A 40 / 0080 K4.0-4.0-08.0-08.0SABB
RF cable GSC-GSC cable 50 mm cable 100 mm	MuRata	Ordering numbers: MXTK 88 TK 0500 MXTK 88 TK 1000
GSC connector	MuRata	MM9329-2700 TB2
P/N M22001 tool (recommended for GSC antenna installation)	MuRata	Please use product name: P/N M22001
Handset	Votronic	HH-SI-30.3/V1.1/0
Siemens Car Kit Portable	Siemens	Siemens ordering number L36880-N3015-A117
DSB35 Support Box	Siemens	Siemens ordering number L36880-N8101-A100-3

Description	Supplier	Ordering information
BB35 Bootbox	Siemens	Siemens ordering number L36880-N8102-A100-1