

BIPOLAR STEPPER MOTOR CONTROL

By Pierre PAYET BURIN

This application note is intended to provide design details for the implementation of a stepper motor control, built around the TEA3717.

This integrated circuit has been developed to offer control and current regulation of up to 1A, in one winding of a bipolar motor.

Two TEA3717s and a minimum of external components are sufficient to implement the full control function of a two-phase bipolar stepper motor.

The system can be commanded, according to the desired mode of operation, by either fixed or programmable logic.

FUNCTIONAL DESCRIPTION

The circuit is organized around a H-bridge configured by four transistors and their integrated free wheel diodes.

The "Phase" input controls the switching of the bridge transistors and also determines the direction of

the current flow in the winding. The signal applied to this input is first gated through a Schmidt trigger and then through a delay element so as to avoid a simultaneous conduction of transistors when direction of current in the bridge is reversed.

Regulation of winding current is performed by chopping action on the power supply for a duration t_{off} determined by a monostable.

This monostable is triggered by the output level swing of a comparator, to the input of which a voltage proportional to delivered output current is applied.

The current spikes corresponding to the diodes reverse recovery time are filtered by a low pass filter $R_C C_C$ to not trigger the comparator.

Three comparators are available for this purpose : their thresholds are internally fixed ratios of V_R input voltage. Each of them can be selected individually by using I_1 and I_0 inputs.

Figure 1 : TEA3717 Block Diagram.

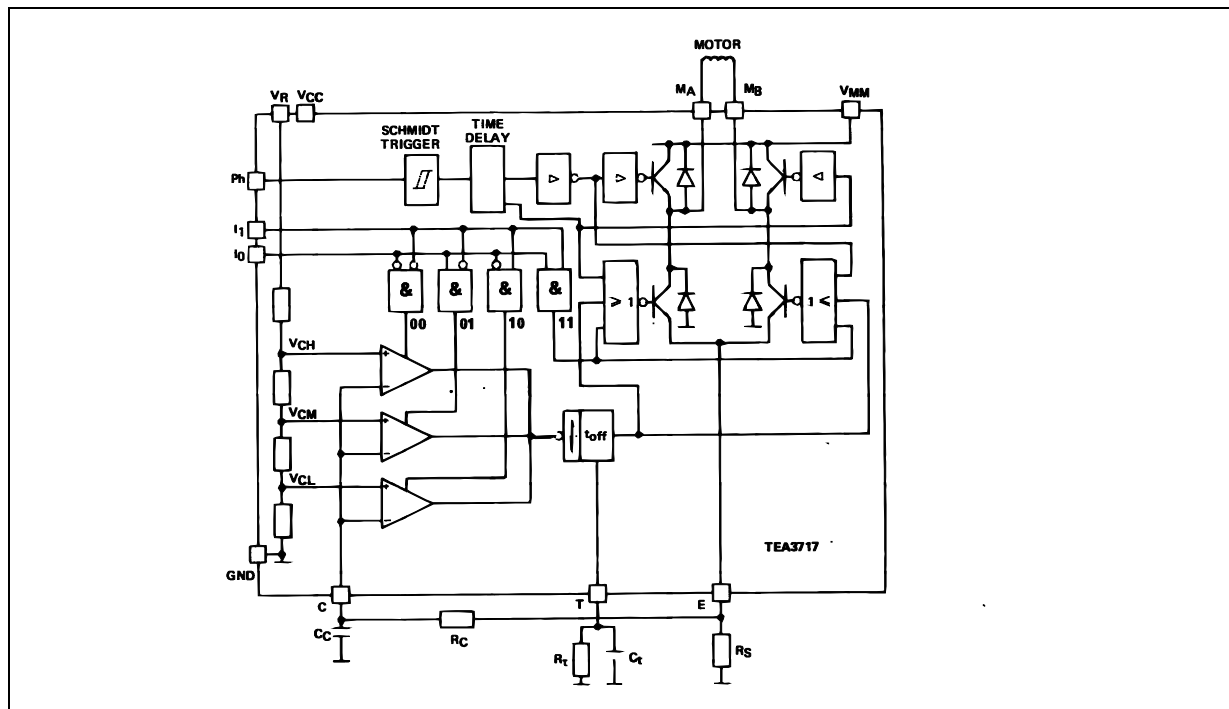

APPLICATION NOTE

Figure 2 : Typical Operating Sequences.

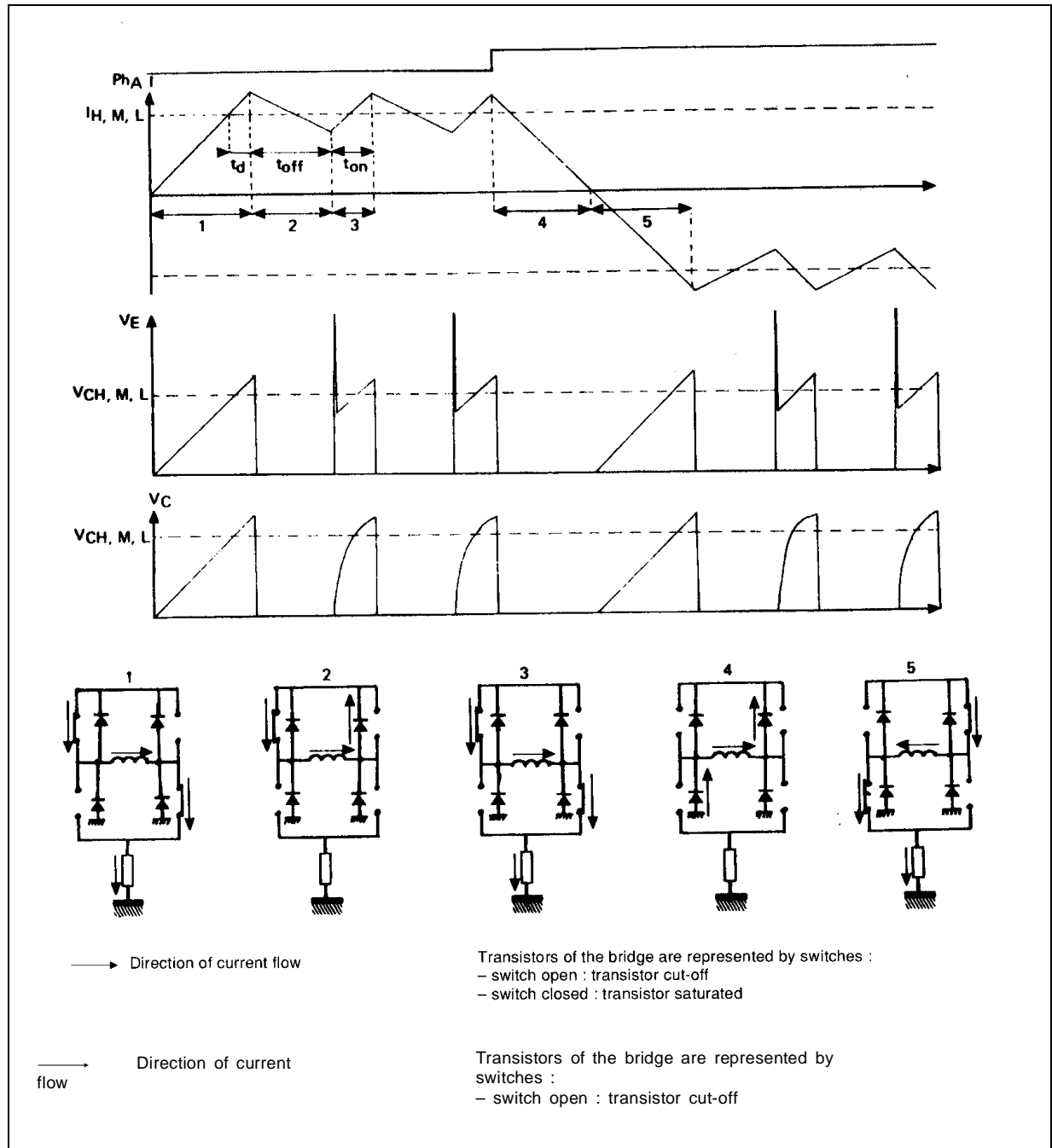

CONTROL OF BIPOLAR TWO-PHASE MOTOR

The proposed diagram features two TEA3717s each controlling one winding. Full-step and fraction-of-a-step operation is performed by combined use of phase and current level selection control inputs.

Figure 3 : Control of a Bipolar Two-phase Motor.

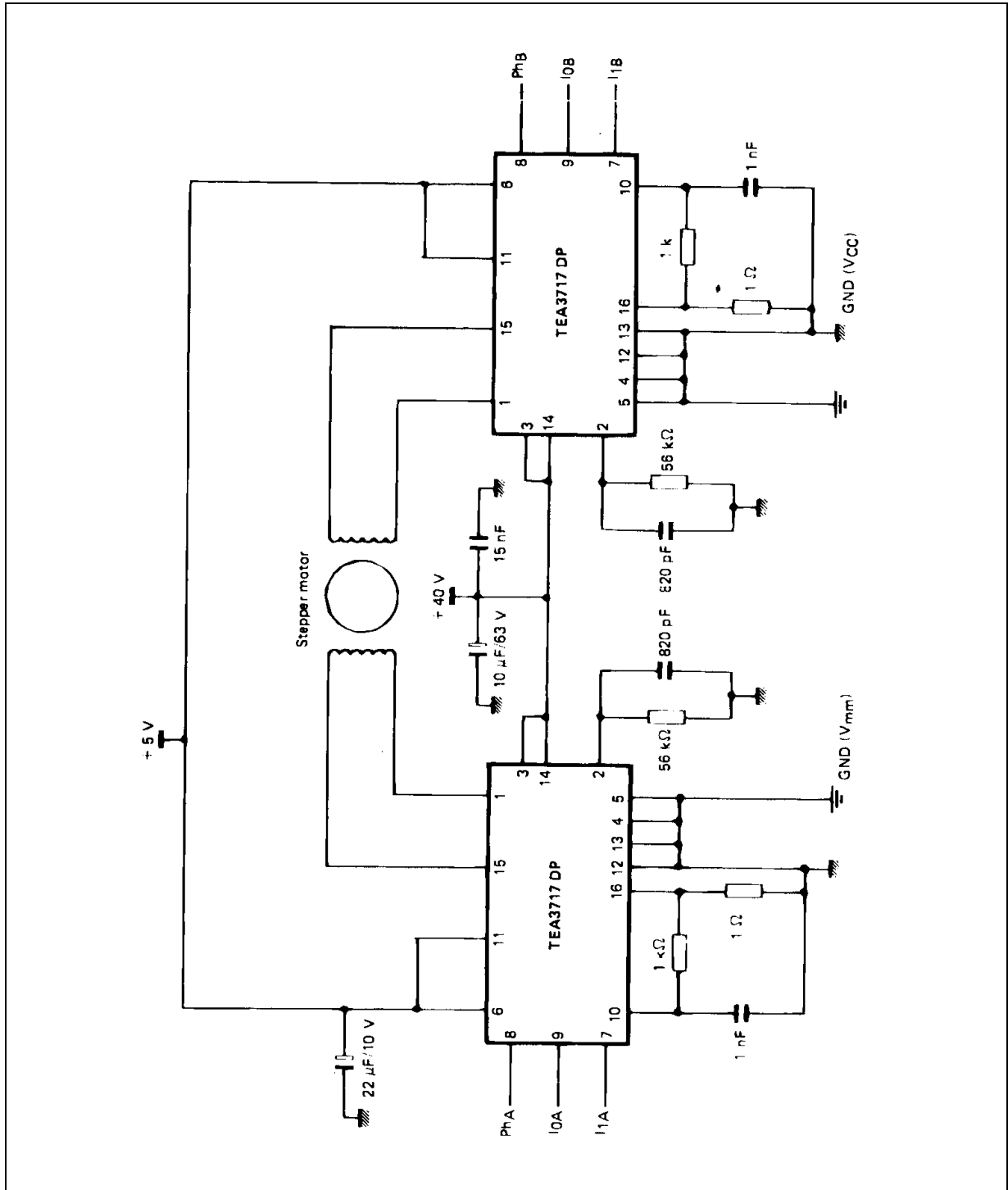

APPLICATION NOTE

Figure 4 : Winding Currents for Rotation in Full-and Micro-steps.

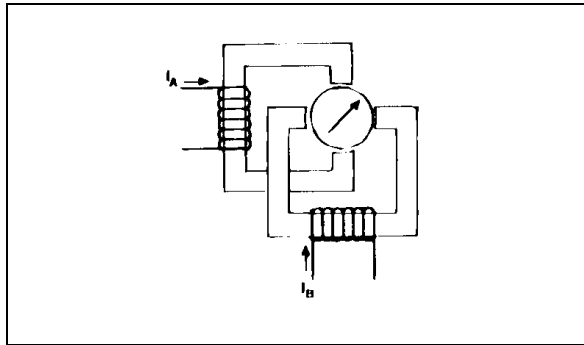

I_A, I_B : Currents flowing through motor windings.
 I_H, I_M, I_L : Current thresholds selected by I_0, I_1 .
 I : any of I_H, I_M or I_L values.

I_0	I_1	I
1	1	0
0	1	I_L
1	0	I_M
0	0	I_H

N° of steps	I_A	I_B
1	I	I
2	I	$-I$
3	$-I$	$-I$
4	$-I$	I

Full step.

N° of steps	I_A	I_B
1	I	I
2	I	0
3	0	$-I$
4	$-I$	$-I$
5	$-I$	0
6	0	I
7	I	I

1/2 step.

N° of steps	I_A	I_B
1	I	I
2	I_M	I_L
3	I_M	$-I_L$
4	I	$-I$

1/3 step.

N° of steps	I_A	I_B
1	I	I
2	I_M	I_L
3	I	0
4	I_M	$-I_L$
5	I	$-I$

1/4 step.

N° of steps	I_A	I_B
1	I	I
2	I_H	I_M
3	I_H	I_L
4	I_H	$-I_L$
5	I_H	$-I_M$
6	I	$-I$

1/5 step.

N° of steps	I_A	I_B
1	I	I
2	I_H	I_M
3	I_M	I_L
4	I	0
5	I_M	$-I_L$
6	I_H	$-I_M$
7	I	$-I$

1/6 step.

N° of steps	I_A	I_B
1	I	I
2	I_H	I_M
3	I_M	I_L
4	I_H	I_L
5	I_H	$-I_L$
6	I_M	$-I_L$
7	I_H	I_M
8	I	$-I$

1/7 step.

N° of steps	I_A	I_B
1	I	I
2	I_H	I_M
3	I_M	I_L
4	I_H	I_L
5	I	0
6	I_H	$-I_L$
7	I_M	$-I_L$
8	I_H	$-I_M$
9	I	$-I$

1/8 step.

FULL-STEP OPERATION :

This is moto's typical mode of operation. Simultaneous power supply to both windings guarantees availability of maximum torque.

"Phase" inputs determine the direction of current flow in the windings, while inputs I_0 and I_1 at a constant level, select the level of this current. This is the simplest type of control implementation.

Figure 5 : Signals to Provide to Controller for Full-step Rotation.

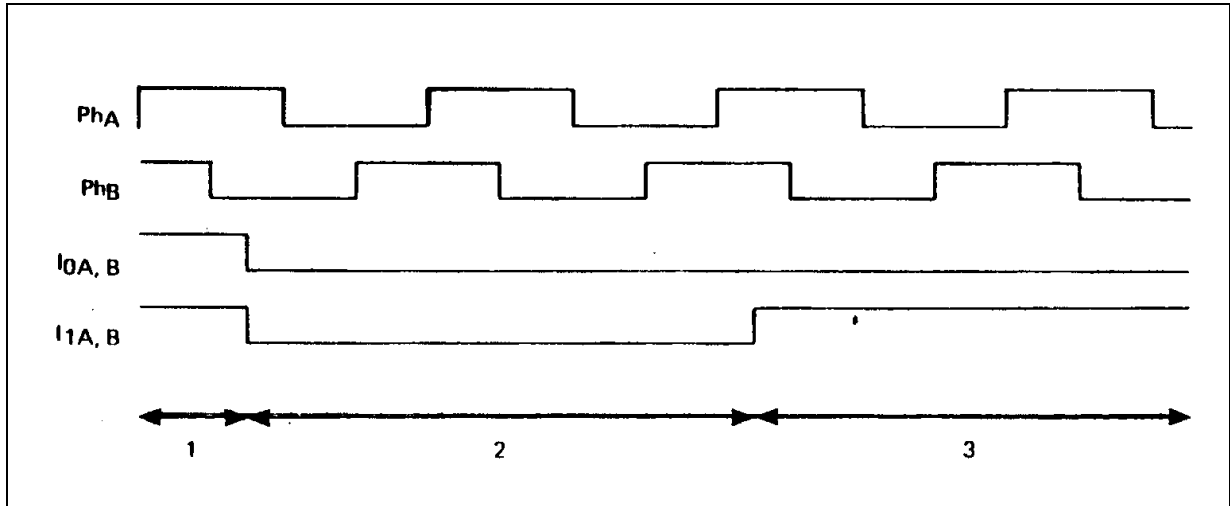

- 1 - Motor not controlled.
- 2 - Rotation of 7 steps @ I_H max. current.
- 3 - Rotation of 6 steps @ I_L low current.

HALF-STEP OPERATION :

This mode allows to double the motor resolution and also to eliminate certain vibrations. Power is applied alternately to one winding and then to both. In half-step position, where only one winding is powered,

torque available on motor spindle is at its lowest value.

Same control signals as those used for full-step operation are applied to "phase" inputs, and I_0 , I_1 inputs are used to annul the current in one winding.

APPLICATION NOTE

Figure 6 : Signals to Provide to Controller for Full-step Rotation.

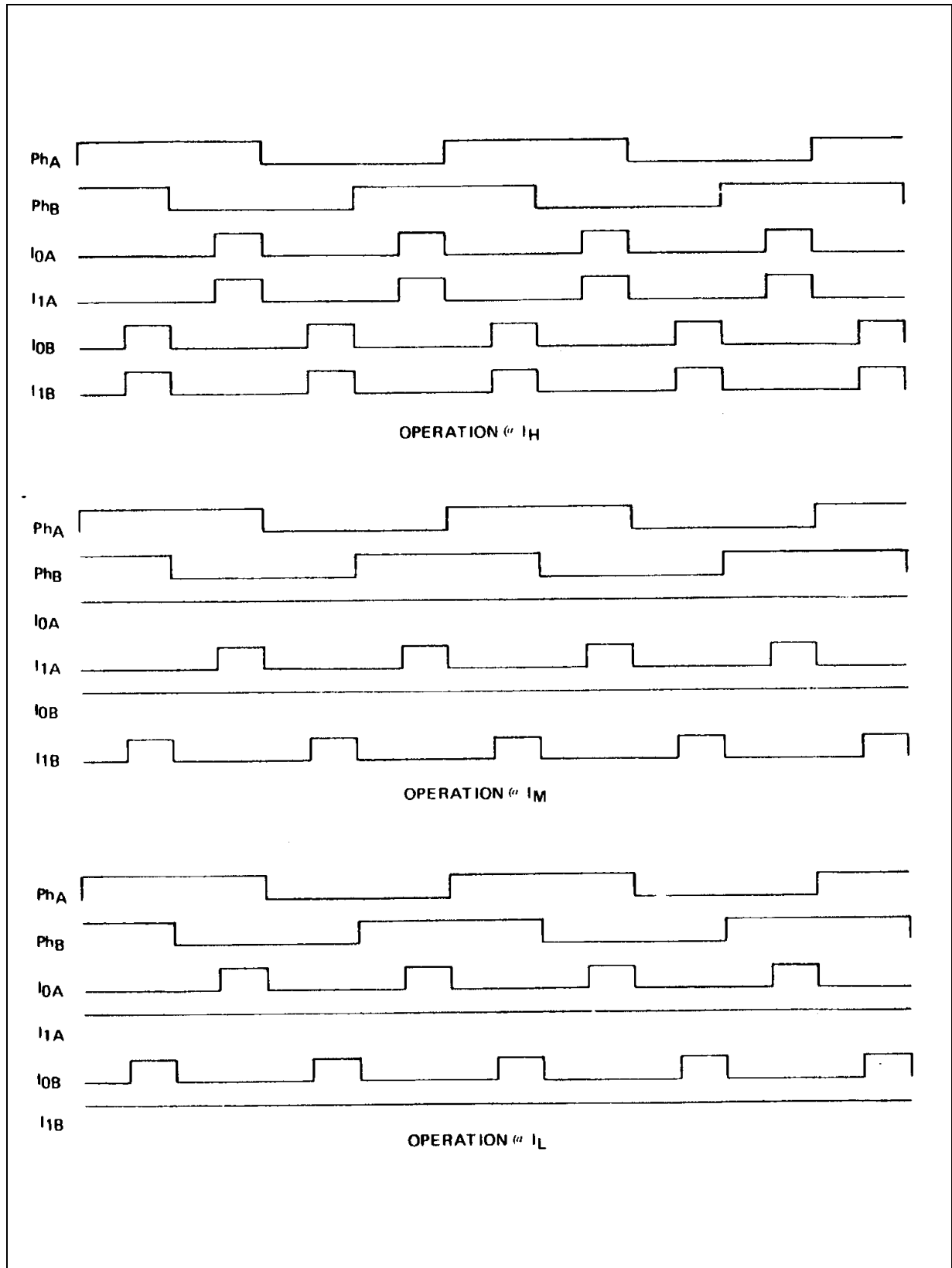

MICRO-STEP OPERATION:

Micro-steps of up to 1/8 are obtained by implementing the flow of different supply current levels through both windings.

This type of operation may be envisaged if a good rotational regularity is required.

Some factors reduce the positioning precision of mi-

Figure 7 : Signals to Provide to Controller for Rotation in 1/8th of a Step.

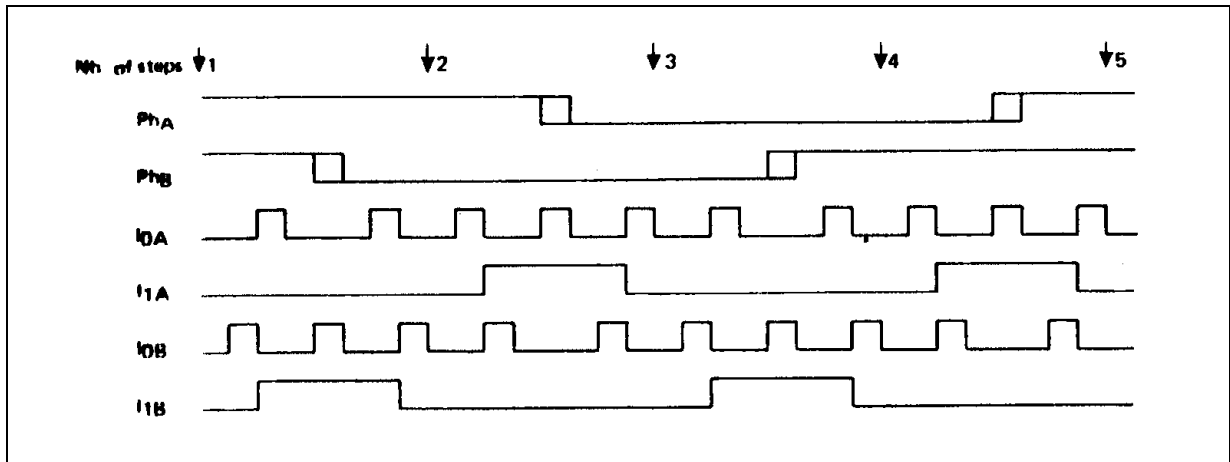

cro-steps :

- difference between theoretical value and available value for winding current,
 - comparator threshold levels dispersion,
 - motor winding characteristics dispersion.
- These factors don't affect full-step position

CHOICE OF OPERATING FREQUENCY

Motor's rotational speed is determined by the frequency of PhA and PhB signals.

This speed is limited by the mechanical characteristics and the time constant of L, r circuit formed by the winding.

The rate of current increase in the winding depends on V_{mm} . Thus, if operation at maximum speed is desired, it would be a good practice to work with high supply voltages.

Figure 8 : Phase Currents for two Differents Speeds.

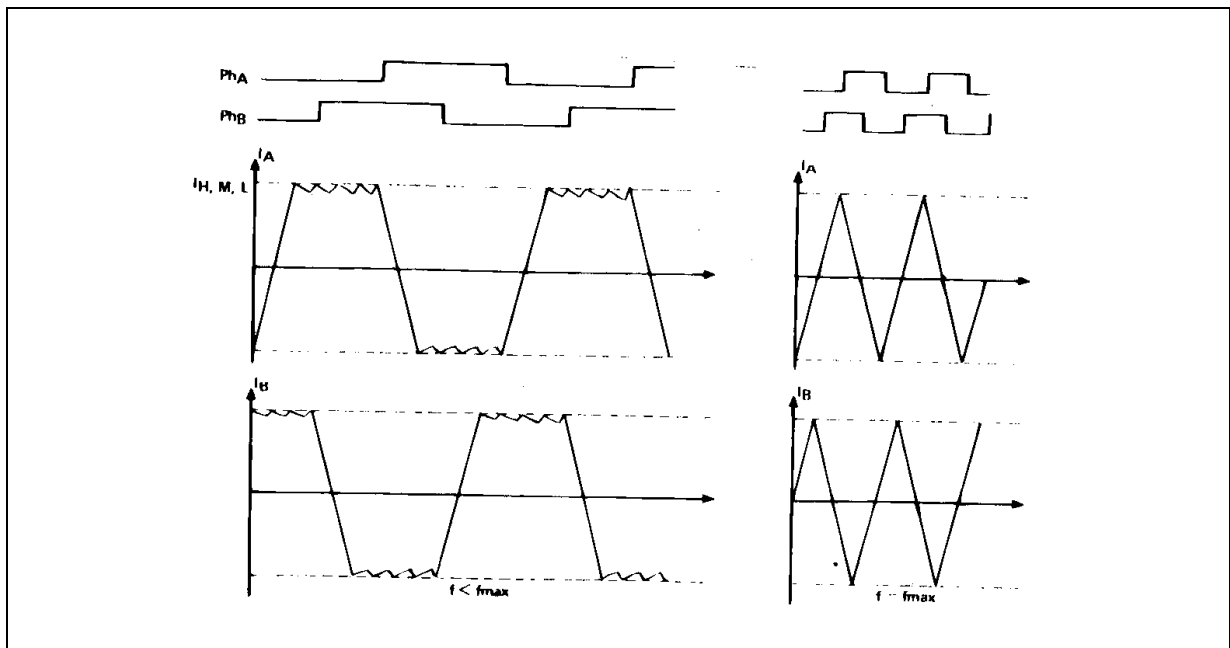

APPLICATION NOTE

$I_1 = I_0 = Ph$ COMMAND

Simultaneous application of control signals to three inputs Ph, I_1 and I_0 (or to Ph and one of I inputs while the other is at high level), is used for half-step operation or unipolar mode.

It must be ensured that the time t during which $Ph = I_1 = I_0 = 1$ is higher than the time t_{min} required to annul the winding current.

If while the current is still positive, control signals $Ph : I_0 = I_1 = 1$ are applied to corresponding inputs, diode D2 or D3 will conduct and cause Q1 and Q4 to be turned-off, which prevents the current rise in the winding and disturbs the proper motor operation.

Blocking of Q1 and Q4 is performed by a built-in protection unit and prevents the parasitics generated by the conduction of D2 and D3 to cause any short-circuit within the bridge.

Figure 9 : Operation with $Ph = I_1 = I_0$.

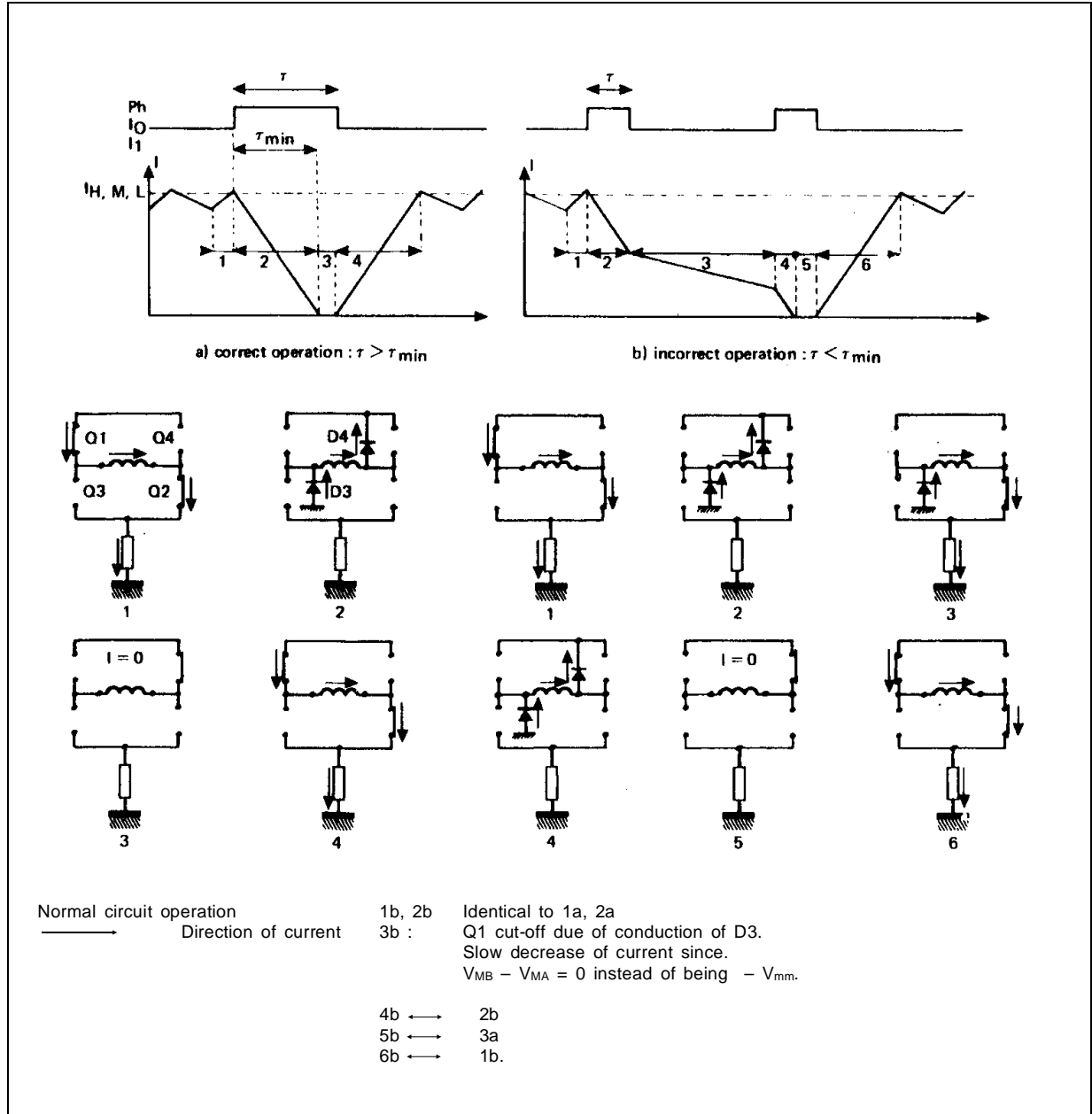

CHOICE OF T_{OFF} : SWITCHING TIME FOR CURRENT REGULATION

The value of t_{off} determines the quality of the current regulation in one phase.

The larger the t_{off}, the more important is the current ripple.

Value of t_{off} is found from the expression $t_{off} = 0.69 R_t C_t$ where $1k\Omega \leq R_t \leq 100k\Omega$

A suitable value of t_{off} for the majority of applications is 30µs.

***t_{off(max)}**

This is the t_{off} value over which the ripple value becomes excessive

Let's k be the desired ripple value and $t = L/r$ the time constant of motor winding, then :

t_{off(max)} is given approximately by : $t_{off(max)} \approx kt$

Figure 10 : Winding Current @ off (max).

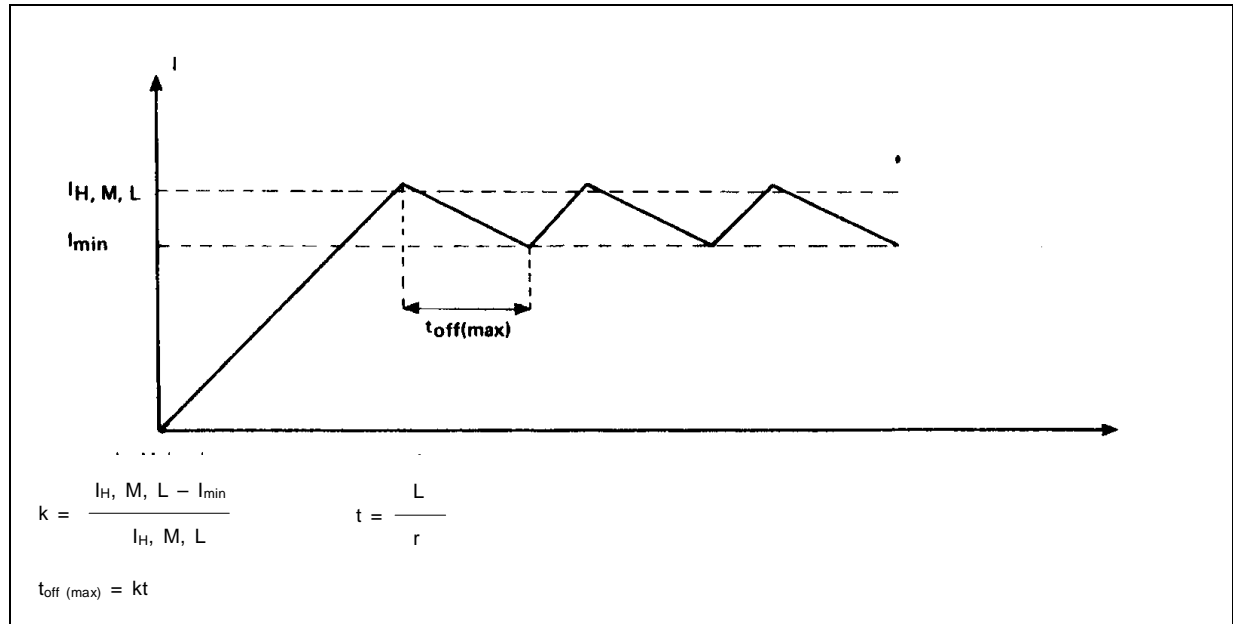

APPLICATION NOTE

* $t_{off(min)}$

This is the limit under which the current regulation is not guaranteed.

Even if the current continually exceeds the threshold levels I_H , I_M or I_L , the device will ensure a minimum conduction time $t_{on(min)}$ which is combination of two periods :

- t_d : comparator trigger time and transistor desaturation time imposed by TEA3717

- t'_d : this is the time required by V_C to reach the comparator threshold level and is determined by low pass filter R_C , C_C .

Therefore, t_{off} must be selected to be long enough to allow the current to fall to a level below I_H , I_M or I_L .

Supply voltage V_{mm} and winding characteristics both determine the value of $t_{off(min)}$.

Figure 11 : Winding Current @ $T_{OFF(MIN)}$.

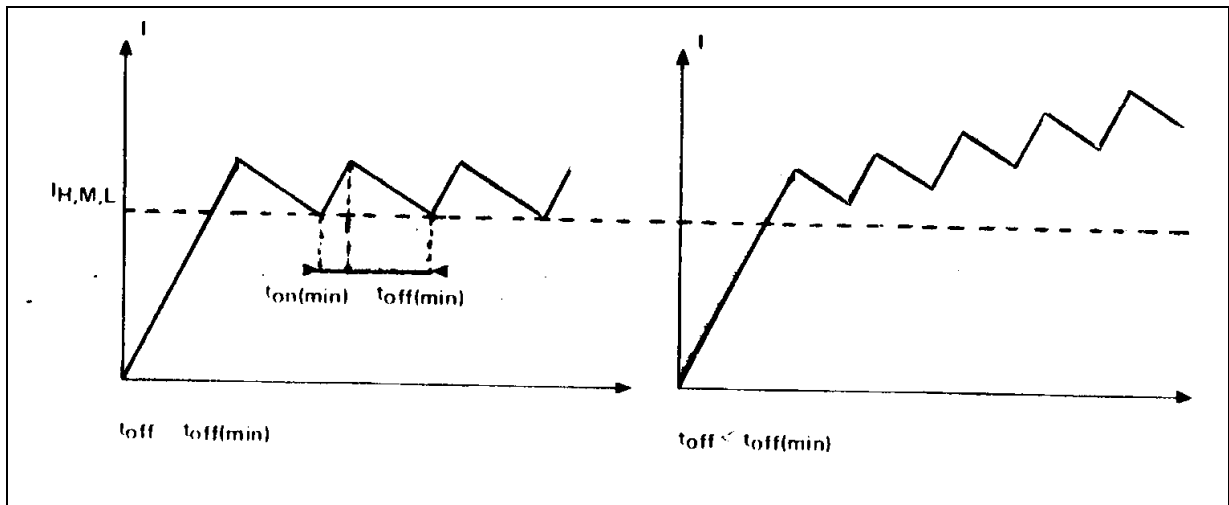
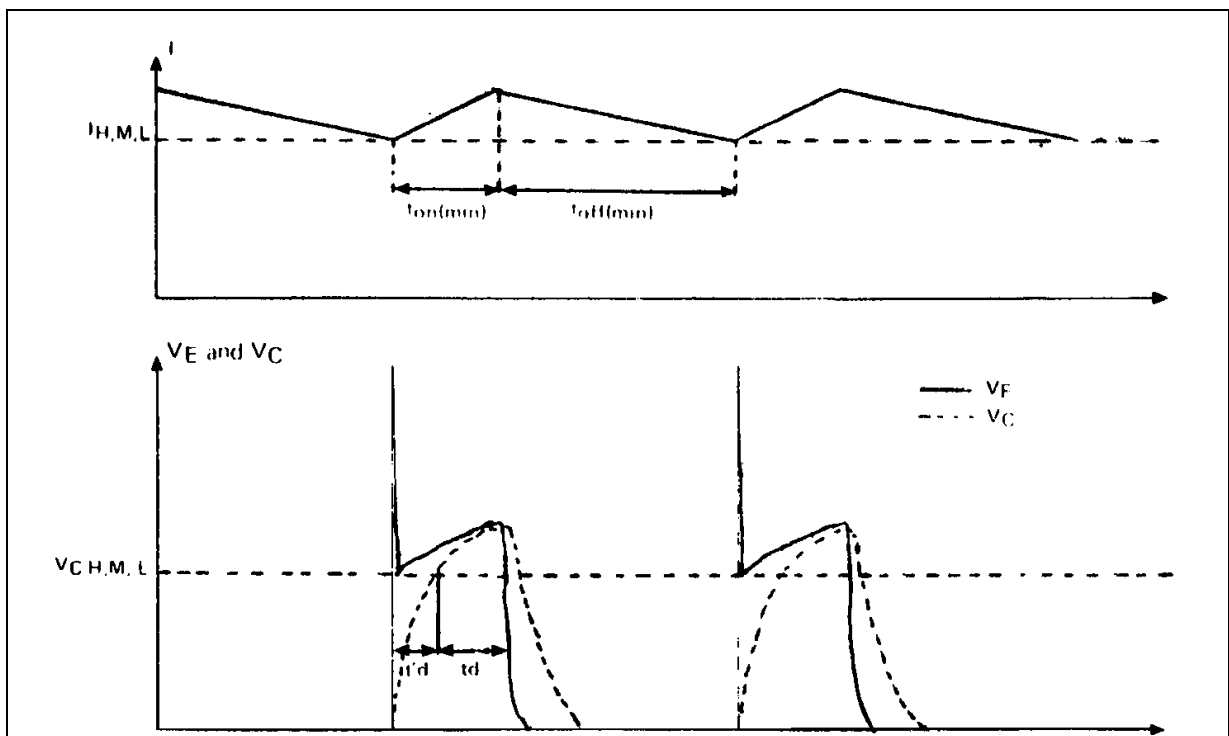

Figure 11 Bis : Winding Current, V_E and V_C Voltages @ $T_{OFF(MIN)}$.



SELECTION OF R_S VALUES

Three values of motor current I_H , I_M and I_L are determined by the choice of R_S and V_R values.

The value of R_S is calculated such that $V_{CH} = R_S \cdot I_H$
 where $V_{CH} = \frac{0.42}{5}$

V_R and I_H is the maximum motor supply current.

A choice of R_S value around 1Ω will guarantee a fast increase of the winding current and offers the possibility of operation with a voltage around 5 V for V_R , and thus is suitable for most applications.

It is also possible to vary the motor current in a continuous mode :

- by V_R adjustment
- by feeding back a portion of the voltage drop across R_S through a potentiometer whose wiper is connected to the comparator input.

In order to minimize the differential voltage $V_E - V_C$ due to comparator's input current, care must be taken to avoid the appearance of a large impedance between E and C terminals. Appropriate values of P and R_C would be : $P = 1\text{ k}\Omega$ and $R_C = 470\Omega$.

CABLING

Figure 12 : Continuous Variation of Current Level.

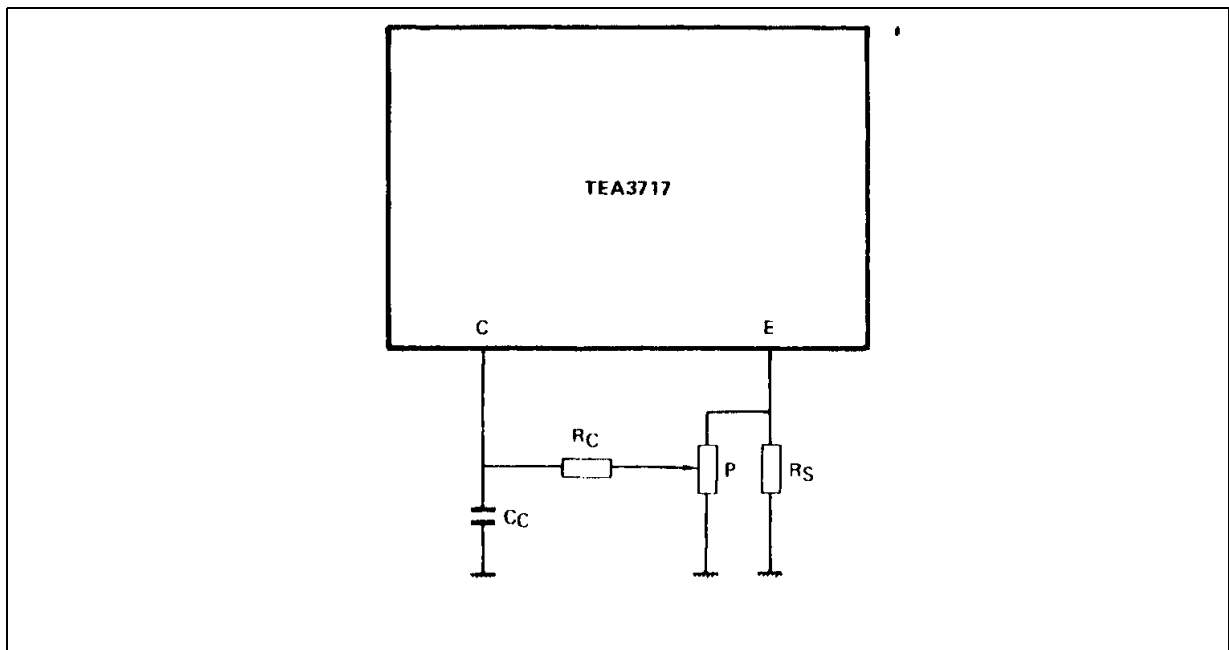

APPLICATION NOTE

Since the TEA3717 operates in switch mode, it is essential to take particular cabling precautions so as to avoid the generation of interferences susceptible to disturb the correct operation of the control electronics.

Recommended precautions are :

- Separated ground connection for V_{mm} supply

- Connection link between RS and the TEA3717 must be kept as short as possible
- Decoupling of V_{mm} by a ceramic capacitor (15 to 150nF) directly connected to the TEA3717 and also by an electrolytic of higher value : 10 to 22 μ F.
- Decoupling of V_{cc} .

Figure 13 : TEA3717 PC Board Layout.

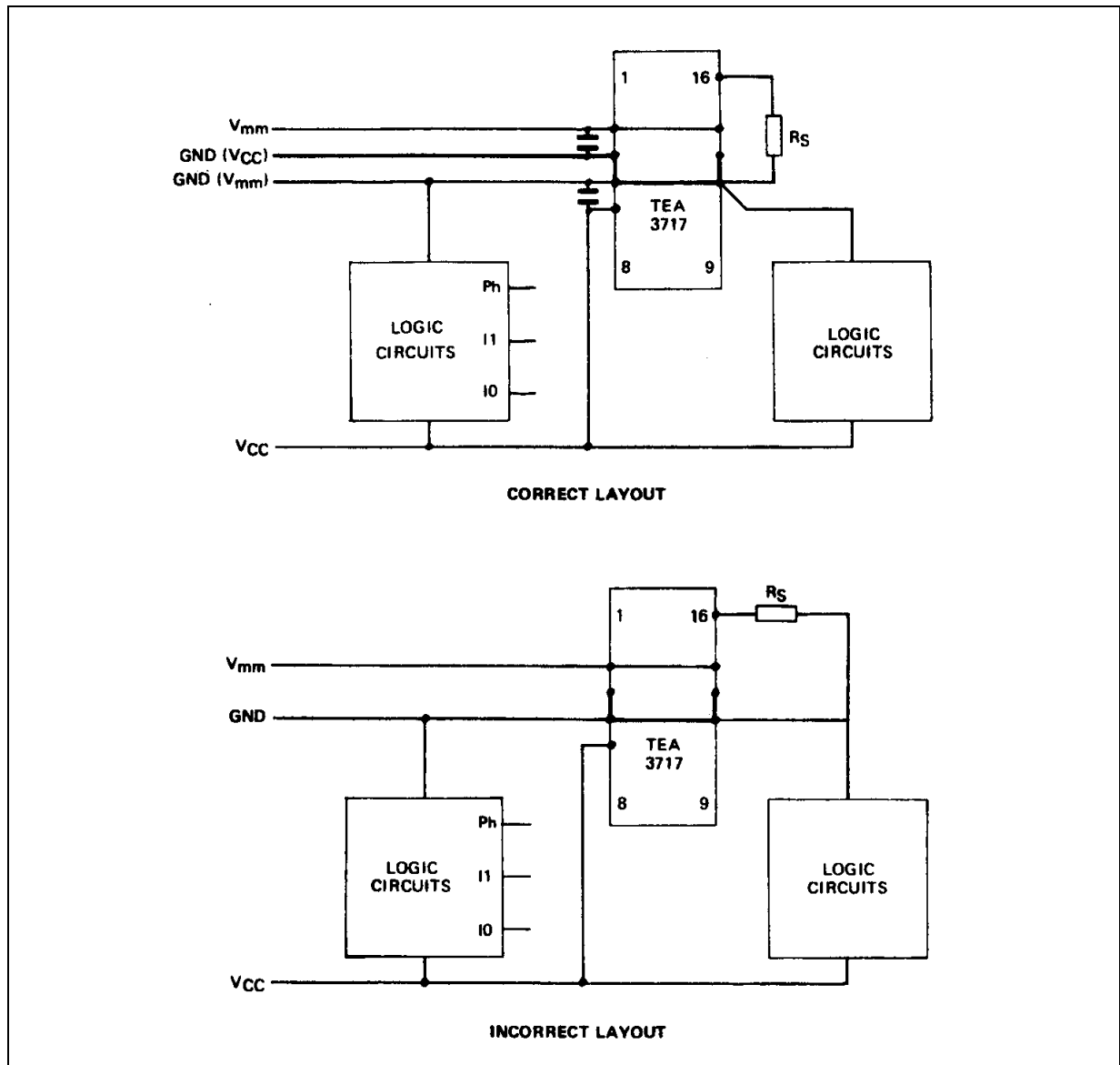

Information furnished is believed to be accurate and reliable. However, SGS-THOMSON Microelectronics assumes no responsibility for the consequences of use of such information nor for any infringement of patents or other rights of third parties which may result from its use. No license is granted by implication or otherwise under any patent or patent rights of SGS-THOMSON Microelectronics. Specifications mentioned in this publication are subject to change without notice. This publication supersedes and replaces all information previously supplied. SGS-THOMSON Microelectronics products are not authorized for use as critical components in life support devices or systems without express written approval of SGS-THOMSON Microelectronics.

© 1995 SGS-THOMSON Microelectronics All Rights Reserved

SGS-THOMSON Microelectronics GROUP OF COMPANIES

Australia - Brazil - France - Germany - Hong Kong - Italy - Japan - Korea - Malaysia - Malta - Morocco - The Netherlands - Singapore - Spain - Sweden - Switzerland - Taiwan - Thailand - United Kingdom - U.S.A.