

E8 WIRING DIAGRAM

34 PIN CONNECTOR

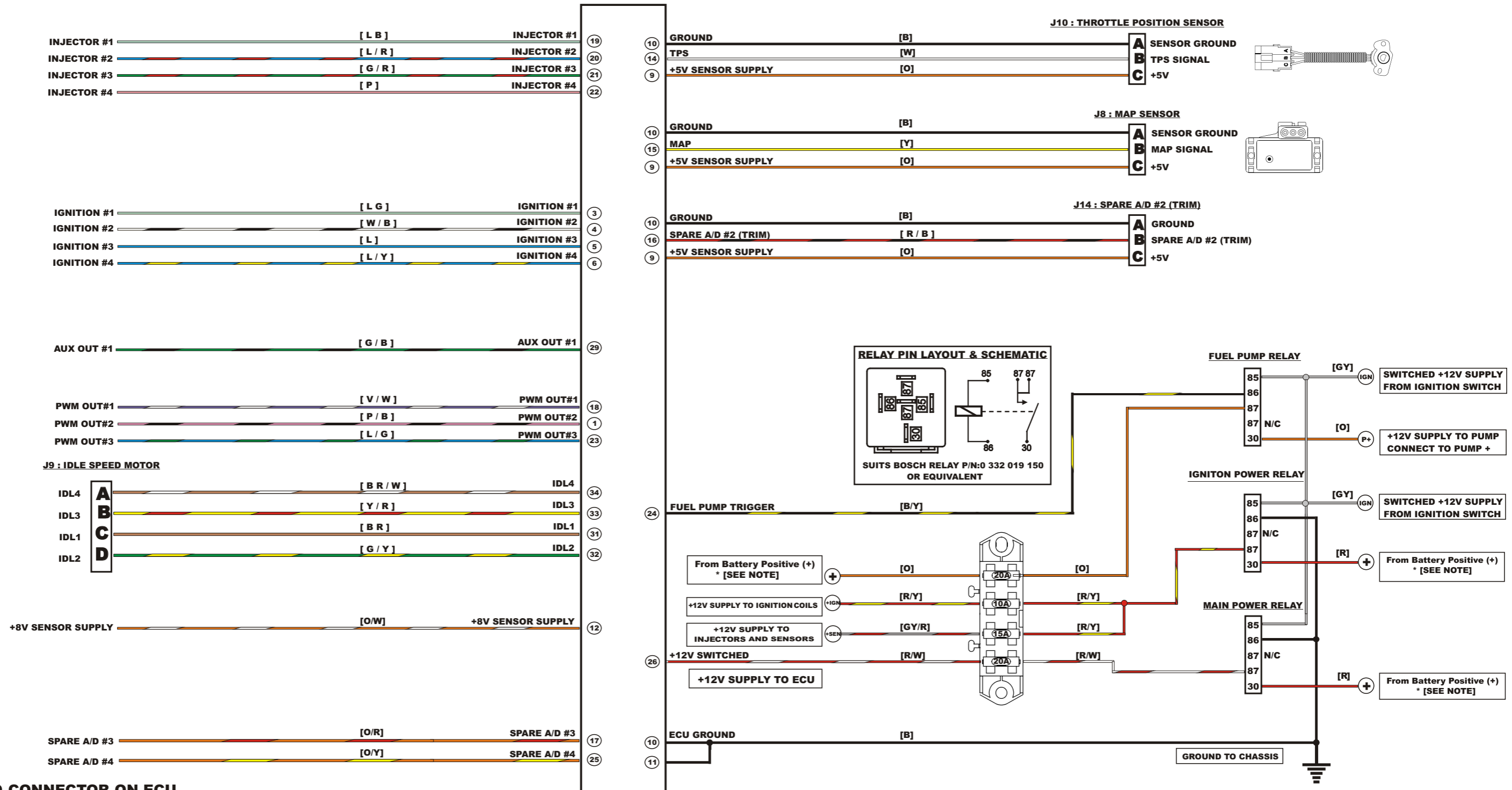

LOOKING INTO CONNECTOR ON ECU

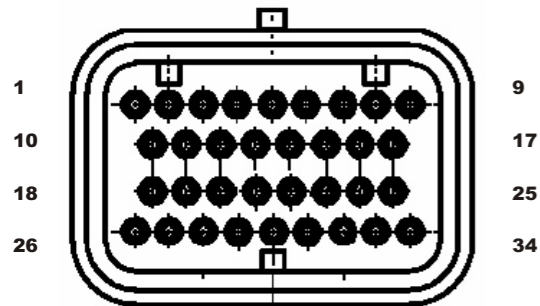

LEGEND - WIRE COLOUR:

B = BLACK BR = BROWN G = GREEN GY = GREY L = BLUE O = ORANGE P = PINK R = RED V = VIOLET Y = YELLOW

WHEN TWO COLOURS ARE USED IN A WIRE BY THE ALPHABETICAL CODE, THE FIRST LETTER INDICATES THE BASIC WIRE COLOUR, THE SECOND COLOUR INDICATES THE COLOUR OF THE STRIPE.

* NOTE: Can Use 100A Circuit Breaker

E8 WIRING DIAGRAM

26 PIN CONNECTOR

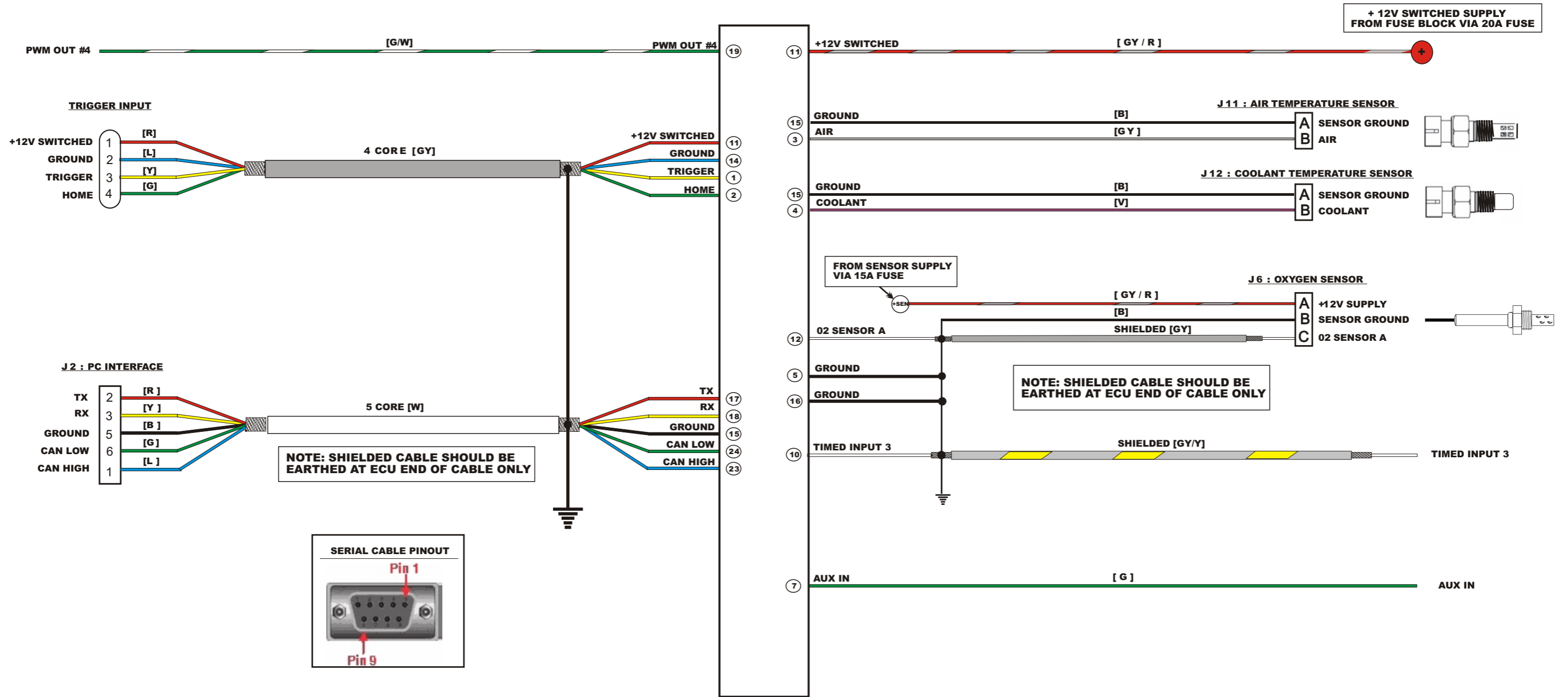

LOOKING INTO CONNECTOR ON ECU

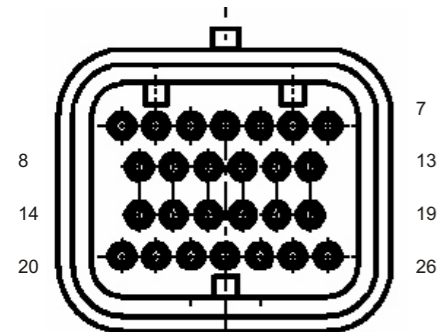

LEGEND - WIRE COLOUR:

B = BLACK BR = BROWN G = GREEN GY = GREY L = BLUE O = ORANGE P = PINK R = RED V = VIOLET Y = YELLOW

WHEN TWO COLOURS ARE USED IN A WIRE BY THE ALPHABETICAL CODE, THE FIRST LETTER INDICATES THE BASIC WIRE COLOUR THE SECOND COLOUR INDICATES THE COLOUR OF THE STRIPE.