

**INSTRUCTION
MANUAL**

BK PRECISION

3025

.005 Hz to 5 MHz

SWEEP/FUNCTION GENERATOR

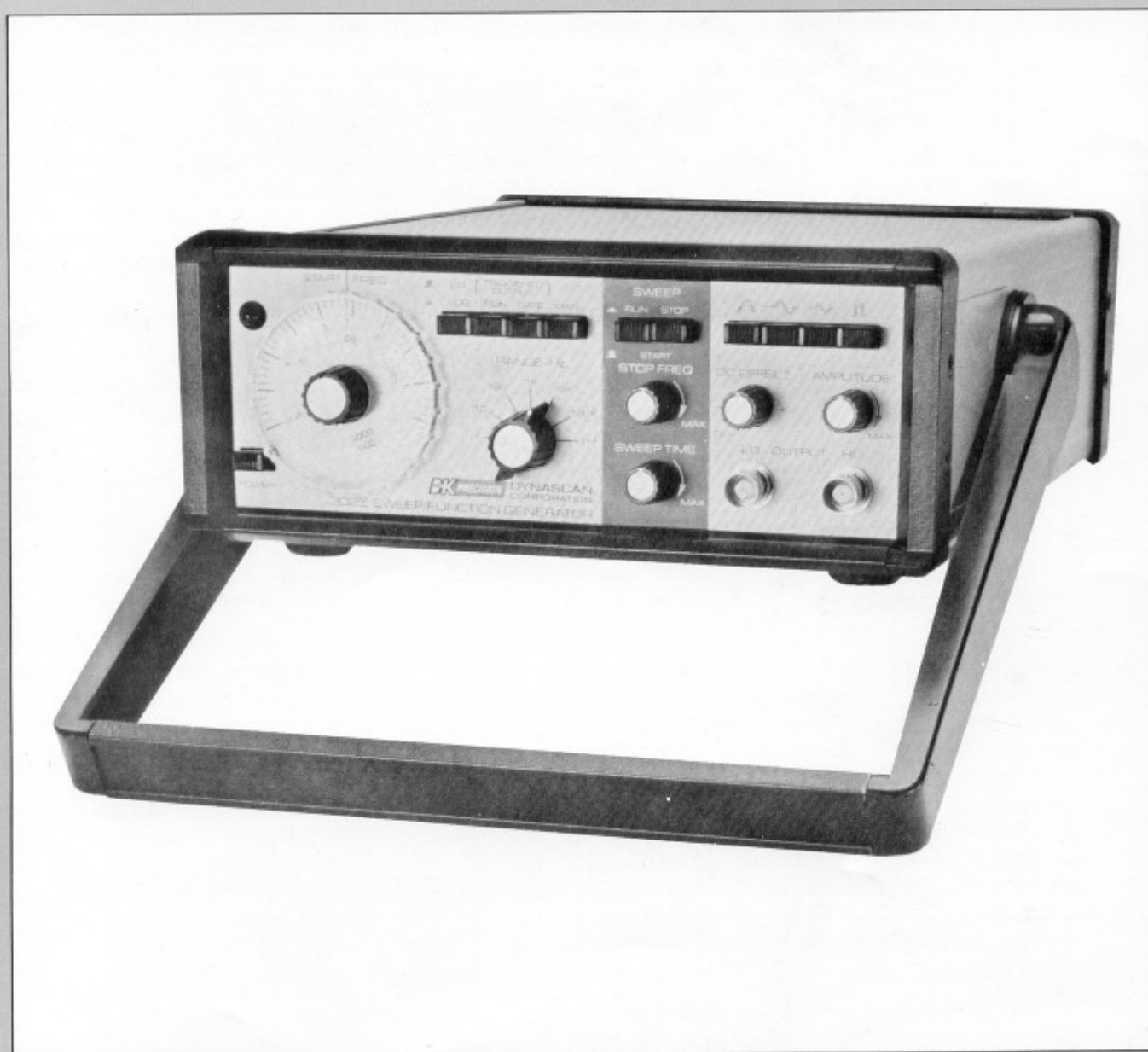

BK PRECISION DYNASCAN
CORPORATION

TEST INSTRUMENT SAFETY

WARNING

Normal use of test equipment exposes you to a certain amount of danger from electrical shock because testing must often be performed where exposed high voltage is present. An electrical shock causing 10 milliamps of current to pass through the heart will stop most human heartbeats. Voltage as low as 35 volts dc or ac rms should be considered dangerous and hazardous since it can produce a lethal current under certain conditions. Higher voltage poses an even greater threat because it can more easily produce a lethal current. Your normal work habits should include all accepted practices that will prevent contact with exposed high voltage, and that will steer current away from your heart in case of accidental contact with a high voltage. You will significantly reduce the risk factor if you know and observe the following safety precautions:

1. Don't expose high voltage needlessly. Remove housings and covers only when necessary. Turn off equipment while making test connections in high-voltage circuits. Discharge high-voltage capacitors after removing power.
2. If possible, familiarize yourself with the equipment being tested and the location of its high voltage points. However, remember that high voltage may appear at unexpected points in defective equipment.
3. Use an insulated floor material or a large, insulated floor mat to stand on, and an insulated work surface on which to place equipment; and make certain such surfaces are not damp or wet. Where insulated floor surface is not available, wear heavy gloves.
4. Use the time-proven "one hand in the pocket" technique while handling an instrument probe. Be particularly careful to avoid contacting a nearby metal object that could provide a good ground return path.
5. When using a probe, touch only the insulated portion. Never touch the exposed tip portion.
6. When testing ac powered equipment, remember that ac line voltage is usually present on some power input circuits such as on-off switch, fuses, power transformer, etc. any time the equipment is connected to an ac outlet, even if the equipment is turned off.
7. Many equipments with two-wire ac power cords are transformerless "hot chassis" powered, where one side of the ac power line connects directly to the chassis. If such equipment does not have a polarized plug to prevent insertion the "wrong" way, a serious shock hazard exists if the chassis is touched. Not only does this present a dangerous shock hazard, but damage to test instruments or the equipment under test may result from connecting the ground lead of most test instruments (including this generator) to a "hot chassis". To make measurements in "hot chassis" equipment, always connect an isolation transformer between the ac outlet and the equipment under test. The **B & K-Precision** Model TR-110 Isolation Transformer is suitable for most applications. To be on the safe side, treat all two-wire ac powered equipment as "hot chassis" unless you are sure it has an isolated chassis or an earth ground chassis.
8. Never work alone. Someone should be nearby to render aid if necessary. Training in CPR (cardio-pulmonary resuscitation) first aid is highly recommended.

Instruction Manual
for



Model 3025

.005 Hz to 5 MHz

Sweep/Function Generator

BK PRECISION **DYNASCAN**
CORPORATION

6460 West Cortland Street
Chicago, Illinois 60635

TABLE OF CONTENTS

INTRODUCTION	1
SPECIFICATIONS.....	2
CONTROLS AND INDICATORS.....	3
Front Panel	3
Rear Panel.....	5
OPERATING INSTRUCTIONS	6
Continuous Run Operation.....	6
Sweep Operation	8
Triggered Output Operation	10
External Control of VCF	11
Combination of Modes	13
THEORY OF OPERATION	14
MAINTENANCE AND CALIBRATION	17
Line Voltage Selection	17
Calibration Adjustments	17
WARRANTY INFORMATION	21
Warranty Service Instructions	21
Warranty	21

INTRODUCTION

The **B & K-Precision** Model 3025 is a versatile signal source which combines three functions into one unit - waveform generation, frequency sweep, and triggered operation. With this versatility, it has a vast number of applications in both analog and digital electronics in the engineering, manufacturing, servicing, educational, and hobbyist fields.

The heart of the function generator is a VCF (voltage-controlled-frequency) circuit that produces precision sine, haversine, square, or triangle waves over the .005 Hz to 5 MHz range. This encompasses subaudible, audio, ultrasonic, and RF applications. A continuously variable dc offset allows the output to be injected directly into circuits at the correct bias level.

The sweep generator offers linear or log sweep with variable sweep rate and independent start and stop frequencies. Sweeps can thus be either up or down in frequency.

Sweep range is up to 4 decades (10,000:1), permitting applications such as frequency tests through the audio range and beyond with one sweep. The frequency response of any active or passive device up to 5 MHz can easily be determined.

Triggered operation enables the output to be gated by an external control signal. The unit can be set to output either tone bursts or single cycles in response to the trigger signal. Triggering can also be accomplished manually from a front panel pushbutton. Gated output is always in full cycles, eliminating frequency components not harmonically related to the frequency being gated.

In addition to the above features, an external signal may be used to control operating frequency. This is useful in FM applications, or in situations where an externally controlled sweep is desirable.

SPECIFICATIONS

Waveforms	Sine, triangle, square, haversine.	SYNC OUTPUT	Square wave, TTL level, greater than +3 V. 50 Ω output impedance.
Modes of Operation	Continuous run, sweep (linear or logarithmic), triggered (tone burst or single-cycle), external VCF.	VCF Range	0 to +5 V input for 1000:1 linear (10,000:1 log) frequency change.
Frequency Range	0.005 Hz to 5 MHz.	Gate and Trigger	Requirement: Manual or external voltage of approximately +1.4 volts for turn-on. Input: dc coupled, approximately 10 k Ω input impedance.
Frequency Accuracy (linear mode)	$\pm 5\%$ of full scale.	V:f OUTPUT (Voltage Proportional to Frequency)	0 V to +5 V output for 1000:1 linear (10,000:1 log) frequency range.
HI OUTPUT	50 Ω output impedance. 20 V p-p open circuit. 10 V p-p into 50 Ω . <i>3.6 RMS</i>	Sweep Generator Modes of Operation	Start, run, stop.
LO OUTPUT	50 Ω output impedance. 2 V p-p open circuit. 1 V p-p into 50 Ω . <i>1.5 mV MIN RMS</i>	Sweep Rate	Approximately 10 ms to 1 min, continuously adjustable.
DC OFFSET	Variable, switched on or off by detented control. + 10 V to - 10 V open circuit; + 5 V to - 5 V into 50 Ω .	Sweep Limits	Up to 3 decades (1000:1) linear, 4 decades (10,000:1) log. Starting and stopping frequencies set by individual controls; allows sweeping up or down in frequency.
Square Wave		SWEPT OUTPUT	Ramp waveform when sweep mode is RUN. (0 V to +5 V).
Rise and fall times	< 50 ns. <i>37 (+)</i> <i>45 (-)</i>	Power Requirements	100/120/220/240 VAC; 50/60 Hz; 25 Watts.
Overshoot and ringing	< 5% of max. p-p voltage (50 Ω termination).	Size (HWD)	21 x 8.9 x 28 cm (8.3 x 3.5 x 11").
Symmetry (Time)	$\pm (1\% + 10 \text{ ns})$, 1 Hz to 5 MHz.	Weight	2.3 kg (5 lbs).
Sine Distortion	< 0.5%, 1 Hz to 100 kHz; All harmonics > 30 dB down, 100 kHz to 5 MHz.		
Sine Frequency Response	< ± 0.2 dB to 500 kHz. < ± 1.0 dB to 5 MHz.		
Triangle Non-linearity	< 1% (Best straight line method), 1 Hz to 100 kHz.		

NOTE: Unless otherwise stated, specifications apply from 10% to maximum output amplitude terminated into 50 Ω . Specifications are valid for frequency settings between 0.5 and 5.0 on the START FREQ dial at 25 $^{\circ}$ C $\pm 5^{\circ}$ C. Specifications are subject to change without notice.

 SPIKES 10mV
ALWAYS, BOTH OUTPUTS

CONTROLS AND INDICATORS

FRONT PANEL

(see Fig. 1)

1. **Pilot Light.** Glows when unit is on.
2. **START FREQ Dial.** Selects the basic operating frequency; also sets the starting frequency for sweep operation. Dial has two scales; LIN/LOG switch (3) selects either linear (outer) scale, or logarithmic (inner) scale. Frequency is dial reading times RANGE-Hz control (5) setting.
3. **LIN/LOG Switch.** Selects linear or logarithmic characteristics for VCF circuit in all modes.
4. **TRIGGERED OUTPUT Switches.** These two switches select continuous run or triggered operation as follows:
 - a. RUN depressed, GATE released or depressed: Instrument runs continuously at the frequency selected (or sweeps, according to SWEEP (13) setting).
 - b. GATE depressed, RUN released: Gated tone burst operation; generates output for duration of trigger signal from TRIG INPUT jack (16) or MAN switch (14).
 - c. RUN and GATE both released: Single-cycle operation; instrument outputs one cycle for each trigger signal from TRIG INPUT jack (16) or MAN switch (14).
5. **RANGE-HZ Control.** Provides decade changes in frequency. Multiplication of the selected range times the START FREQ dial (2) setting gives the actual output frequency.
6. **Waveform Switches.** Select one of four output waveforms: square wave, triangle wave, sine wave, and haversine.

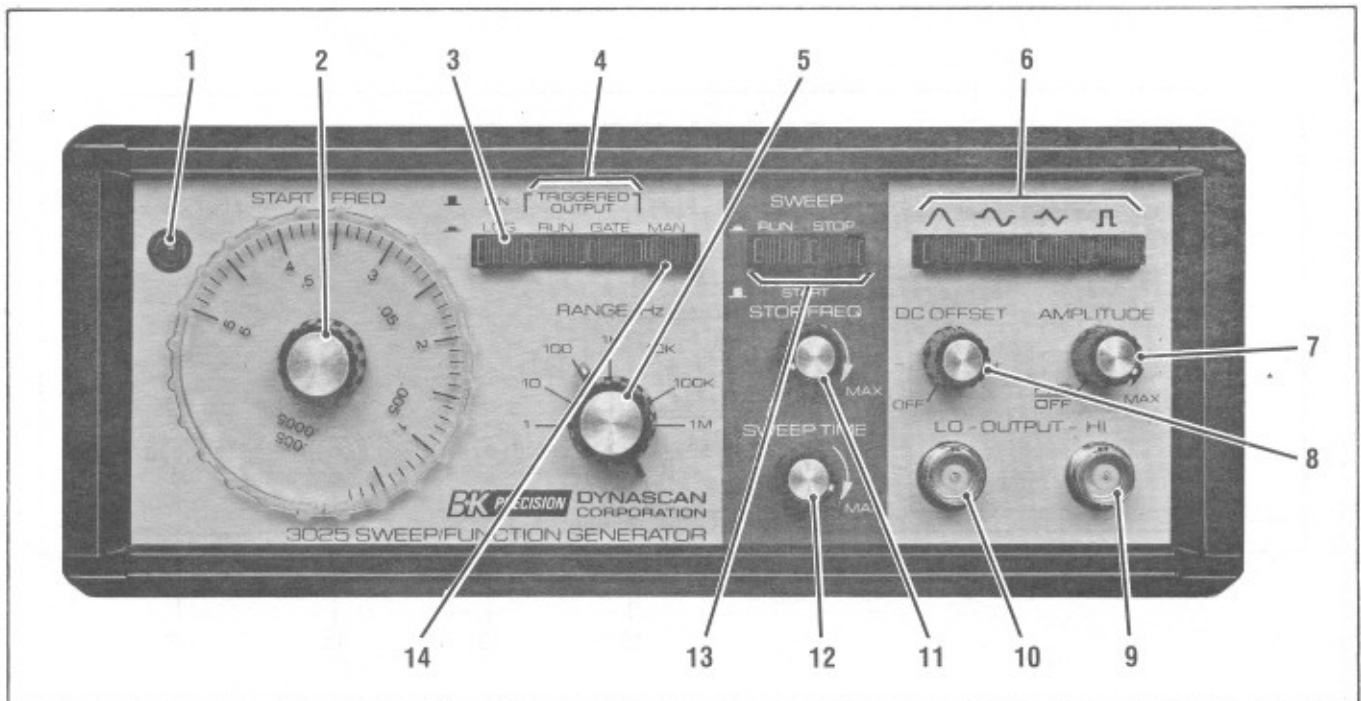

Fig. 1. Front panel controls and indicators.

7. **PWR OFF/AMPLITUDE Control** Turns instrument on and off. Varies the peak-to-peak amplitude of HI and LO OUTPUT (9 and 10) from maximum (fully clockwise) to 30 db below maximum.
8. **DC OFFSET Control.** Varies the dc level of the output (HI OUTPUT ± 10 volts open circuit, LO OUTPUT ± 1 volt open circuit). Zero dc level is obtained by switching this control OFF.
9. **HI OUTPUT.** Main output; maximum 20 volts p-p open circuit, 10 volts p-p into 50 Ω termination.
10. **LO OUTPUT.** Same waveform as HI OUTPUT (9) but attenuated 10:1.
11. **STOP FREQ Control.** Sets the sweep terminating frequency; instrument will sweep to this frequency and return to start a new sweep. Selection is similar to the START FREQ dial (2), and is affected by both the RANGE-Hz control (5) and the LIN/LOG switch (3).
12. **SWEEP TIME Control.** Sets the time to sweep from the START FREQ (2) setting to the STOP FREQ (11) setting. Variable from 10 milliseconds to at least 1 minute.
13. **SWEEP Switches.** Select continuous run or frequency sweep operation as follows:
 - a. RUN released, STOP released or depressed: Instrument runs continuously at the frequency selected by the START FREQ dial (2).
 - b. RUN and STOP both depressed: Instrument runs continuously at the frequency selected by the STOP FREQ control (11).
 - c. RUN depressed, STOP released: Instrument sweeps from frequency selected by START FREQ dial (2) to that selected by STOP FREQ control (11). Sweep can be either up or down in frequency.

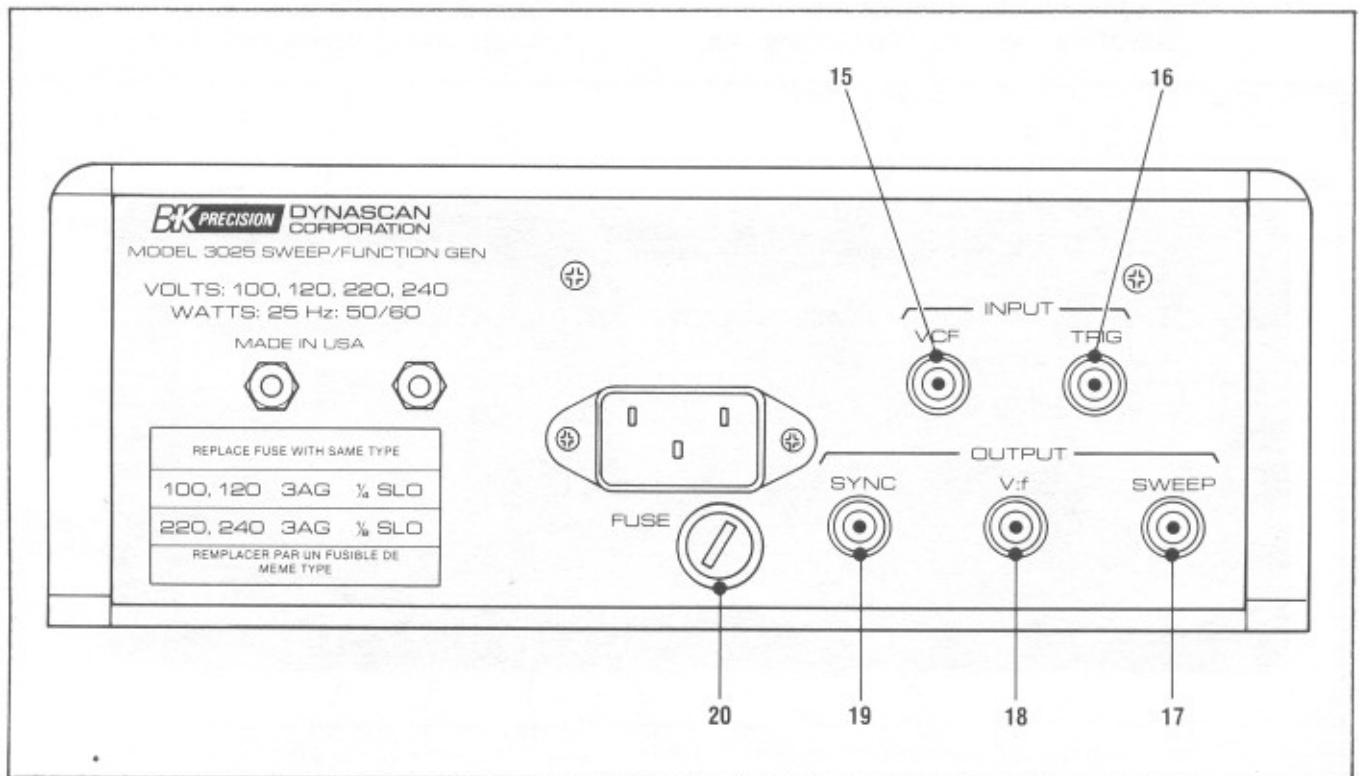

Fig. 2. Rear panel inputs and outputs.

14. **MAN Switch.** Gates the output manually during triggered operation.

REAR PANEL

(see Fig. 2)

15. **VCF INPUT Jack.** Allows frequency control by external voltage. VCF operates from 0 to +5 volts. Voltage applied at this jack is summed with voltage from front panel controls; result determines the VCF operating point. AC voltages about zero will frequency modulate the output around the selected frequency.
16. **TRIG INPUT Jack.** Input for external gating or triggering. When the applied signal goes above 1.6 V the instrument is triggered. The signal must go below 1.3 V to remove the triggered condition. Maximum input is ± 12 V.
17. **SWEEP OUTPUT Jack.** Provides a 0 to +5 volt ramp running at the sweep time rate. During continuous run operation, it is held at one of two levels: 0 volts with unit running at START FREQUENCY and 5 volts when running at STOP FREQUENCY.
18. **V:f OUTPUT Jack.** Provides a voltage proportional to the output frequency. Approximately 0 to +5 volt range.
19. **SYNC OUTPUT Jack.** 0 to +5 volt square wave coincident with the main outputs.
20. **Fuseholder.**

OPERATING INSTRUCTIONS

The model 3025 Sweep/Function Generator is capable of generating a variety of output waveforms. The most benefit and satisfaction can be gained from the instrument by fully understanding its capabilities and versatility and becoming proficient in its operation. One of the best ways to initially gain this familiarization is to connect the generator to an oscilloscope, observe the waveforms, and notice the effects of the various controls on the waveforms. Use this manual as required for reference until becoming accustomed to the operating procedures.

CAUTION

Before connecting unit to line voltage, make sure that LINE VOLTAGE SELECT switches on bottom of case are set properly, and that the fuse is the proper size. See the MAINTENANCE AND CALIBRATION section of this manual for details.

CONTINUOUS RUN OPERATION

Procedure

1. Plug ac power cord into outlet and turn power on with the PWR OFF/AMPLITUDE control (7).
2. To make sure that the output is unaffected by the sweep generator, triggering, or other controls, set the following controls as specified:

CONTROL	POSITION
TRIGGERED OUTPUT (4):	
RUN	Depressed
GATE	Released
SWEEP (13):	
RUN	Released
DC OFFSET (8)	OFF
TRIG INPUT (16)	No Connection
VCF INPUT (15)	No Connection

3. Select the frequency range desired with the RANGE-Hz control (5).
4. Select either linear or logarithmic frequency scale with LIN/LOG switch (3). On the START FREQ dial (2), these ranges are represented by the outer and inner scales, respectively.
5. Set the START FREQ dial to the desired output frequency. The output frequency is the product of the START FREQ setting and the RANGE-Hz setting. For example, a START FREQ setting of 3 (LINEar scale) and a RANGE-Hz setting of 1K produces a 3 kHz output. A START FREQ setting of 0.2 (LINEar scale, last division below 1) and a RANGE-Hz setting of 1 results in a 0.2 Hz output. A START FREQ setting of .005 (LOGarithmic scale) and a RANGE-Hz setting of 1M produces an output of 5 kHz.

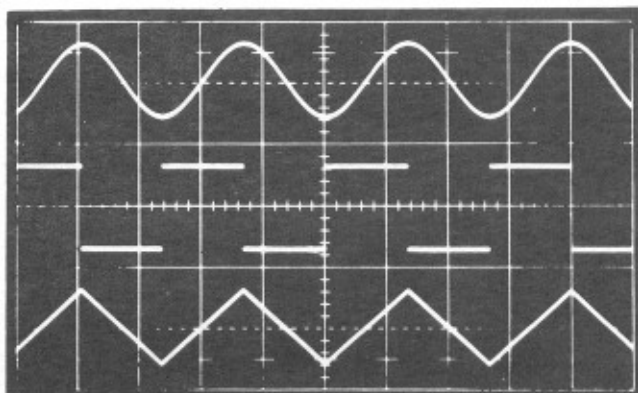

Fig. 3. Sine, square, and triangle waveforms.

6. Select sine, square, or triangle wave by pressing the corresponding waveform switch (6). Fig. 3 illustrates the output waveforms and their phase relationships. NOTE: In continuous run operation, the haversine function (leftmost waveform switch) is identical to the sine. Haversine is discussed in the section on TRIGGERED OUTPUT OPERATION.

- Connect a cable from either the HI or LO OUTPUT (9 or 10) to the desired signal injection point. The HI and LO OUTPUTs have identical output impedances (50Ω) and produce identical waveforms except that the LO OUTPUT is attenuated 10:1 from the HI OUTPUT.

CAUTION

Always make ground connections only to 0 volt points in the circuit under test. All inputs and outputs are connected to earth ground via the 3-wire plug, and connection to a voltage point may damage the equipment being tested.

- Adjust the output to the desired amplitude with the AMPLITUDE control (7).
- A positive or negative dc component can be added to the output signal by use of the DC OFFSET control (8), as required by the circuit into which the signal is being injected. Setting this control to OFF sets the offset to zero.
- A fixed amplitude 0 to +5 volt square wave is available at the SYNC OUTPUT jack (19) on the rear panel. This signal is compatible with TTL circuits, and is unaffected by the AMPLITUDE or DC OFFSET controls. It is always a square wave, regardless of waveform type selected.

Considerations

Knowledge of the following factors is essential for proper operation of the instrument:

- The DC OFFSET control can provide up to ± 10 volts open-circuited, or ± 5 volts into 50Ω . Remember that the combined signal swing plus dc offset is also limited to ± 10 volts open-circuited, or ± 5 volts into 50Ω . Clipping occurs slightly above these levels. Fig. 4 illustrates the various operating condi-

tions encountered when using dc offset. If the desired output is large or if a large dc offset is used, an oscilloscope should be used to make sure that the desired combination is obtained without clipping. The probability of clipping is reduced by keeping the AMPLITUDE control in the lower half of its adjustment range when possible.

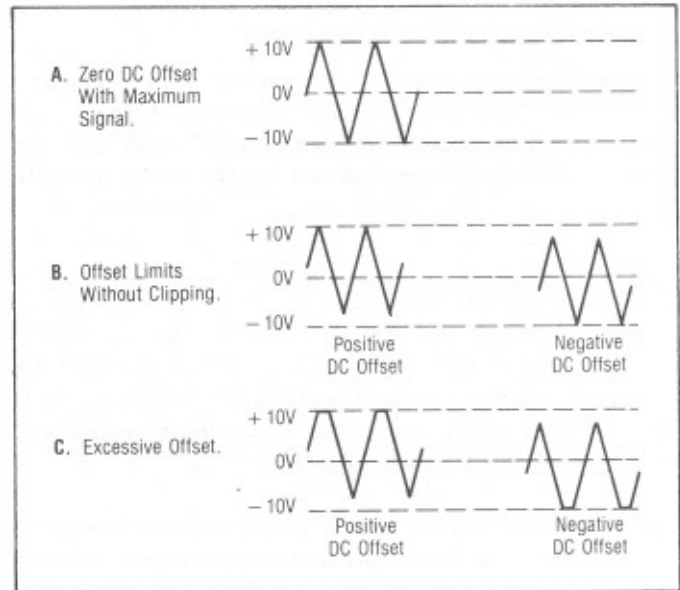

Fig. 4. Use of DC OFFSET control.

- To set the DC OFFSET to a specific dc voltage, depress the waveform switches slightly so that all switches are released (all buttons out). This removes signal from the output and leaves the dc only. Measure the dc output on an oscilloscope or dc voltmeter and adjust the DC OFFSET control for the desired value.
- It is easier to accurately set the START FREQ dial if settings between 0.2 and 5.0 (.005 and 5.0 LOG scale) are used. Since the dial rotation overlaps ranges, it is usually not necessary to use readings below 0.5; just change to a lower range and use a higher dial setting.
- The source impedance from both outputs is 50Ω , but the output may be fed into any circuit impedance. However, the output level varies in proportion to the terminating impedance. If it is

desired to maintain a constant output level while injecting signal into various circuits with different impedances, a constant terminating impedance is necessary. When the generator output is connected to a coaxial connector on the equipment under test, it usually presents a $50\ \Omega$ terminating impedance. Most other circuit points are usually moderate to high impedance. A reasonably constant terminating impedance may be maintained while injecting signal into moderate and high impedance circuits ($500\ \Omega$ and up) by adding a coaxial tee in the output cable and connecting a $50\ \Omega$ termination to one leg. Remove the $50\ \Omega$ termination when injecting into a $50\ \Omega$ circuit. Also keep dc considerations in mind. If dc voltage is present at the signal injection point, the DC OFFSET should be set to match the circuit voltage, or a blocking capacitor may be required to avoid dc loading with $50\ \Omega$.

5. When using the higher output frequencies or the square wave output, terminate the cable in $50\ \Omega$ to minimize ringing. Keep the cables as short as possible.
6. To set output amplitude to a specific level, measure peak-to-peak amplitude on an oscilloscope.
7. To set the output frequency with greater precision (dial accuracy is within 5%), connect the output to a frequency counter.

SWEEP OPERATION

Procedure

1. Set up equipment as for continuous run operation.
2. Select linear or logarithmic sweep with the LIN/LOG switch (3).
3. Select the sweep range with the RANGE-Hz control (5). Sweep can oc-

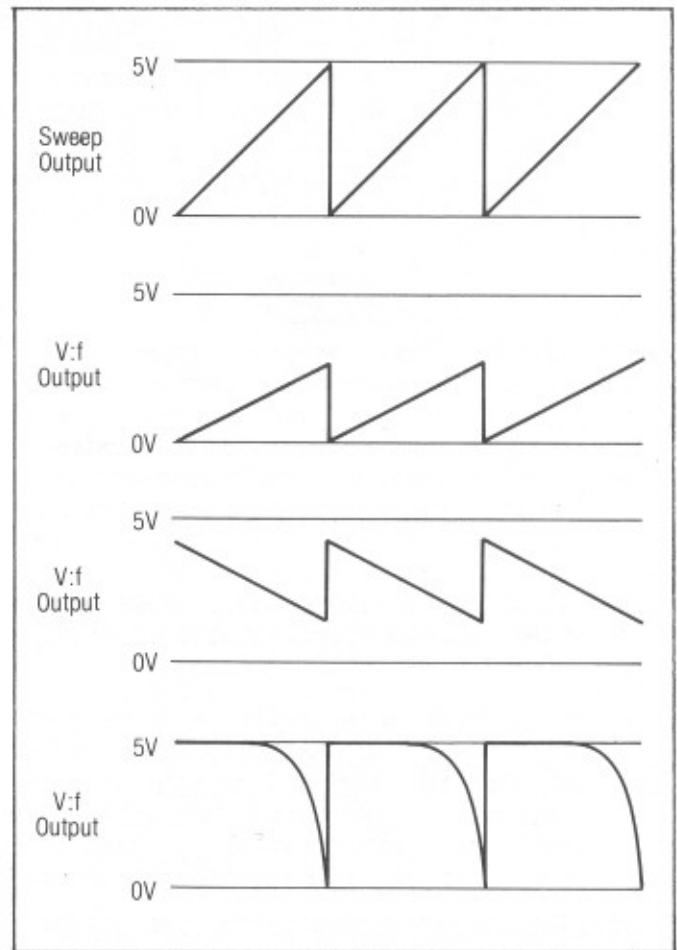

Fig. 5. Sweep and V:f outputs.

cur between any two frequencies accessible with one RANGE-Hz setting.

4. The start frequency is selected by setting the START FREQ dial to the desired value. The unit need not be running in continuous mode to make this selection; however, if greater accuracy is desired, the use of a frequency counter makes it necessary to set for continuous operation while selecting.
5. The stopping frequency is selected by the STOP FREQ control (11). This control encompasses roughly the same range as the START FREQ dial, and is likewise affected by the RANGE-Hz and LIN/LOG controls.
6. As with START FREQ, the stop fre-

quency may be selected regardless of the current operating mode; however, since the STOP FREQ control has no scale, it is desirable to run the unit in STOP FREQ mode when selecting. This is done by engaging both SWEEP (13) switches (RUN and STOP).

7. To run the unit in sweep mode, the SWEEP RUN switch must be engaged and the SWEEP STOP switch must be released.
8. The SWEEP TIME control (12) sets the amount of time required for the unit to sweep from the START FREQUENCY to the STOP FREQUENCY. This time can be varied from approximately 10 ms to 1 minute. Determination of sweep time can best be made when unit is running in sweep operation.

Considerations

1. Separate controls for START and STOP FREQUENCIES make possible sweeping in either direction, either up or down in frequency.
2. Maximum sweep range is 3 decades (1000:1) using linear sweep; 4 decades (10,000:1) with logarithmic.

3. V:f OUTPUT (18) and SWEEP OUTPUT (17) both provide signals which may be used with an oscilloscope to determine the sweep speed at high sweep rates. Simply connect either of these outputs to a scope and measure the ramp interval on the screen. The SWEEP OUTPUT signal is always a 0 to +5 volt linear positive-going ramp, unaffected by changes in sweep range. The magnitude of the V:f OUTPUT ramp, however, is dependent on the frequencies swept, and gives direct visual information about sweep range and direction. See Fig. 5. In the figure the same SWEEP OUTPUT signal is present for any of the three V:f OUTPUT displays.
4. Setting of the SWEEP TIME control is dependent upon the frequencies being swept. A lower repetition rate is required for sweeping of low frequencies, and a high rate may be used for sweeping higher frequencies. The sweep rate must be low enough to allow a few cycles of generator output at the low frequency end of the sweep before the generator sweeps into mid-range. The LOG sweep is sometimes preferred because it does not sweep through the low frequencies as rapidly. A higher sweep rate reduces flickering of the oscilloscope for viewing convenience.

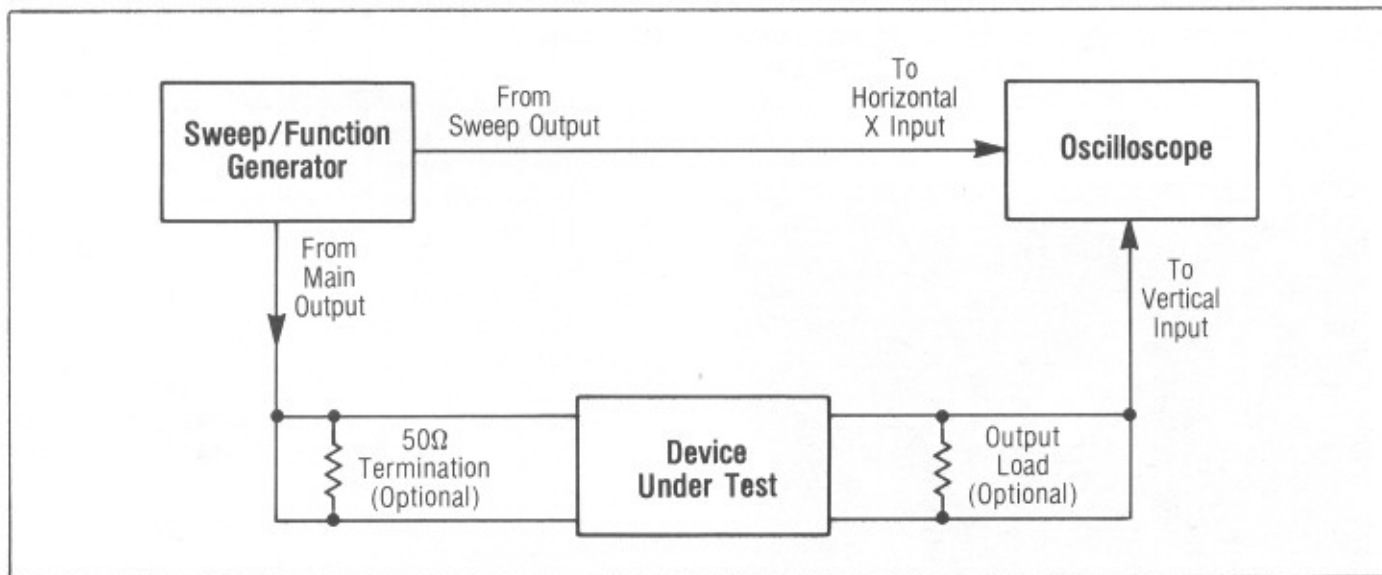

Fig. 6. Frequency response test set-up.

One of the main uses of a sweep generator is checking the frequency response of amplifiers, tone controls, filters, and other frequency sensitive devices. The presence of the linear SWEEP OUTPUT ramp permits observation of response characteristics directly on an oscilloscope in X-Y mode. Output amplitude can be plotted on the vertical axis, and frequency on the horizontal.

The basic set-up is shown in Fig. 6. If the linear sweep method is used, each horizontal graticule marking corresponds to a particular frequency, with equal scale increments representing equal frequency increments.

If the log sweep method is employed (as is appropriate for 20 Hz to 20 kHz audio sweeps), the frequency increments vary in logarithmic fashion along the horizontal axis. For log display, it is important that the horizontal scope input be connected to the *linear* SWEEP OUTPUT ramp rather than V:f OUTPUT. The ramp present at V:f OUTPUT is logarithmic in LOG mode, resulting in a scope display that is always linear, regardless of sweep.

TRIGGERED OUTPUT OPERATION

In triggered output operation the generator output is switched on and off by an external control signal, or by a front panel pushbutton. The 3025 offers two triggered output modes, gated tone burst and single-cycle.

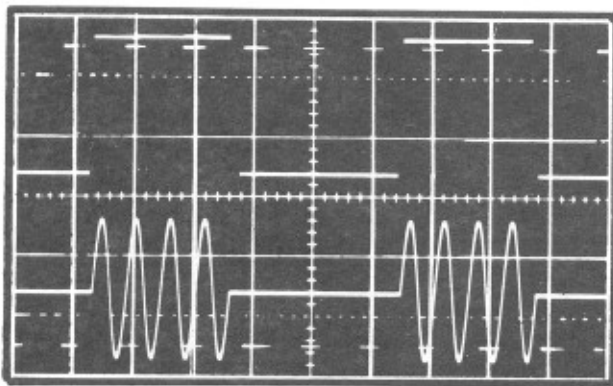

Fig. 7. Gated operation.

In gated tone burst operation the output runs continuously as long as the control signal remains above a certain threshold value. An example is shown in Fig. 7. The top display is the square wave gating signal, and the bottom is the generator sine wave output, which is on only when the gating signal exceeds the threshold.

In single-cycle operation the unit outputs one cycle of the selected waveform for each trigger excursion above the threshold. Fig. 8 gives examples of one-cycle sine, triangle, and square waves as would be obtained using single-cycle mode.

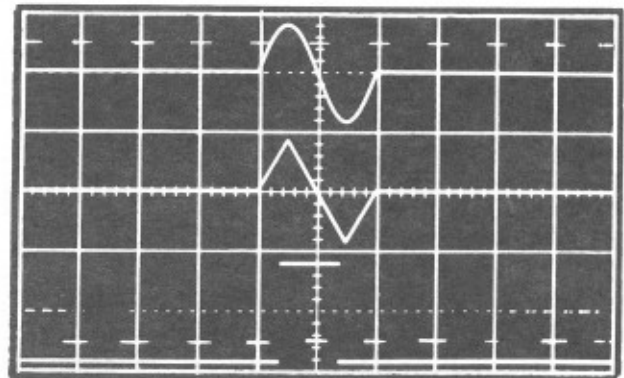

Fig. 8. Single-cycle waveforms.

Gated Tone Burst Operation

Procedure

1. Set up equipment as described for function generator operation; select desired output frequency and amplitude. Display the output of the generator on an oscilloscope.
2. Apply an external gating signal to the TRIG INPUT jack (16) on the rear panel.
3. Engage the GATE switch (4) and release the RUN switch (4). Unit is now in gated operation.

Considerations

1. On and off trigger thresholds are +1.6

volts and +1.3 volts, respectively. Signal must go above +1.6 volts to turn output on, and below +1.3 volts to switch it off.

2. Output can be gated manually using the front panel MAN switch (14).
3. The gated output is always in full cycles, and always ends as a positive-going slope at the zero crossover point. This eliminates transients and frequency components not harmonically related to the frequency being gated.

Single-Cycle Operation

Procedure

1. Set-up is the same as for gated operation, except that both the RUN and GATE switches are released to enable the single-cycle mode.
2. Once this mode is enabled, any excursion by the trigger signal above the threshold value will produce a single cycle of the selected waveform. The output will then remain off until the next positive-going threshold crossing.
3. Each push of the front panel MAN switch (14) will result in a single cycle of output.

Haversine

As stated previously, the haversine and sine functions are identical in continuous run mode. However, the difference is plainly distinguishable in triggered operation. Refer to Fig. 9. It is seen that while a sine wave conventionally extends equal amounts above and below the zero axis, a haversine remains always positive in amplitude. The curve is the same, but the starting points differ. Fig. 9 shows a haversine in single-cycle mode; haversines are also observable in gated operation.

EXTERNAL CONTROL OF VCF

The internal VCF (voltage-controlled frequency) circuit of the 3025 has as its inputs a number of front-panel controls which have already been discussed. In each case, the particular control involved presents a variable voltage to the VCF. The sum of these various control voltages is processed by the VCF to produce a certain output frequency.

The VCF INPUT jack (15) on the rear panel provides direct access for an external control voltage which is in turn summed with all other control inputs to the circuit. This allows external frequency control, making possible three modes of operation:

1. Control by a fixed dc voltage, producing a specific output frequency.
2. Control by an ac voltage, resulting in FM modulation.
3. Control by a ramp (or other type waveform) providing externally controlled sweep generator operation.

Control by fixed dc voltage

1. Set up as for regular continuous run operation, setting operating frequency using front-panel controls.
2. Connect an external voltage to the VCF INPUT jack (15) on the rear panel.
3. Since this voltage input is combined

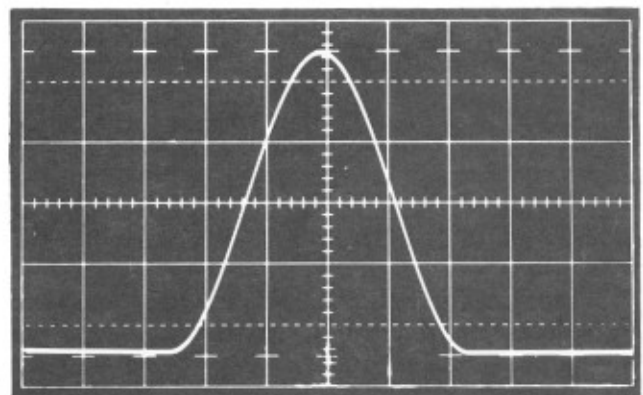

Fig. 9. Haversine.

with those of the front panel, an input of 0 V dc has no effect on the output frequency.

4. As the voltage is deviated around zero in the positive or negative direction, the output frequency increases and decreases accordingly.

Frequency control by external dc voltage is useful in programmed frequency selection. A set of two or more specific frequencies may be programmed by using multiple dc voltage values which may be selected by a switch or electronic switching circuits. This type of operation would be desirable in production testing where signals at several specific frequencies are required for various tests. To maintain the original accuracy each time the operation is repeated, the START FREQ dial must be accurately set to the same position. Probably the easiest way to assure this common dial setting is to set it against its lower stop. The external voltage then exercises complete frequency control, and negative polarity voltages are not required.

Control by AC Voltage-FM Modulation

1. Set up as described for function generator continuous run operation. Use frequency and amplitude controls to set the carrier as desired.
2. Connect an ac modulating signal with no dc component to the VCF INPUT jack.
3. Adjust the amplitude of the ac modulating signal for the desired frequency deviation.

An example of FM modulation is given in Fig. 10. In the figure, a square wave carrier is being modulated by a sinusoidal voltage.

Control by Ramp Voltage

1. Set up as for function generator continuous run operation.
2. Set START FREQ dial to its lowest position. This is not absolutely necessary,

but enables the external voltage to completely control the frequency range.

3. Apply a positive ramp (or other waveform) voltage to VCF INPUT. The amplitude of the external sweep signal now determines the sweep width, and its frequency determines the sweep rate. NOTE: The RANGE-Hz and LIN/LOG controls still affect the frequencies and linearity of the output sweep.
4. Negative sweeps can be obtained by setting START FREQ to its highest setting and applying a negative-going external ramp.

An example of an externally controlled sweep is shown in Fig. 11.

Considerations

The following considerations apply to all modes of operation involving external control of the VCF (voltage-controlled frequency) circuit.

1. Any voltage applied to the VCF INPUT jack is summed with the voltages from the front panel controls. A positive voltage input drives the VCF to a higher frequency. However, the VCF can never be driven beyond its range limits (the highest and lowest frequencies that can be attained on a particular RANGE-Hz setting).

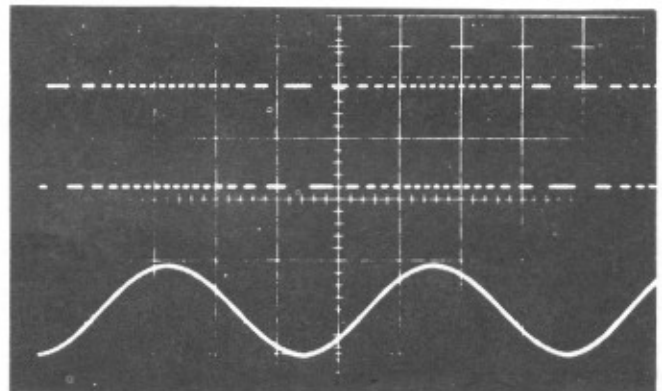

Fig. 10. Frequency modulation.

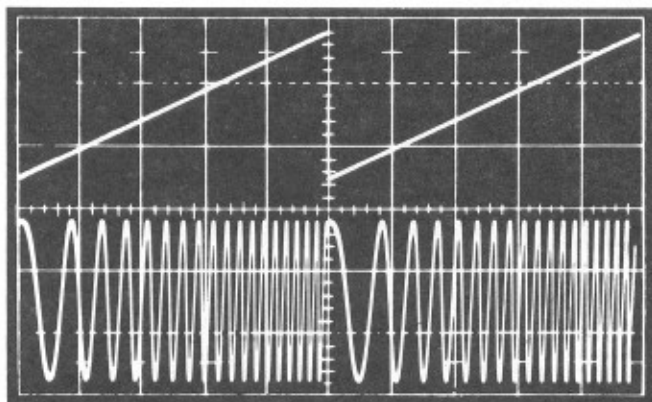

Fig. 11. Frequency control by external ramp.

2. On any RANGE-Hz setting, frequency range limits are spanned by approximately 0 to +5 volts at the internal VCF input (in both linear and log modes). Therefore, the VCF INPUT range needed to cover the band is a five-volt spread somewhere between about +5 and -5 volts dc. For example, if the unit is running in normal continuous mode, and the START FREQ dial is set near its lower limit, then a VCF input of 0 to +5 volts dc covers the available frequency range. In this case, if the VCF voltage goes slightly negative, it brings the output frequency down to the low range limit. Further negative excursions produce no change.
3. The START FREQ dial is usually set to the low end of its rotation when using external VCF control. This reduces the

dial VCF voltage to zero, and allows the external VCF voltage to exercise complete control. It also reduces the effects of dial setting inaccuracy.

4. The output frequency is dependent on the LIN/LOG and RANGE-Hz settings.

COMBINATION OF MODES

The Model 3025 may be operated in many of its modes simultaneously. Following is the list of modes of operation that may be combined, if desired. In each of the combinations, sine, square, or triangle wave output may be used. Haversine is identical to sine except in those instances where gated or single-cycle operation is employed.

Continuous/External VCF

Gated/Sweep

Gated/External VCF

Single-Cycle/Sweep

Single-Cycle/External VCF

External VCF/Sweep

Gated/External VCF/Sweep

Single-Cycle/External VCF/Sweep

CIRCUIT ANALYSIS

The basic waveform of the 3025 is a triangle wave, generated by means of two current sources and a timing capacitor. The capacitor is alternately charged positively and negatively, resulting in a triangular ramp. The three output waveshapes are derived from this triangle. Refer to the block diagram, Fig. 12, for overall analysis and to the separately supplied schematic for specific circuit details.

Main Generator Loop

0 to +5 volts dc is applied at the VCF input R9, or at R8 or R221 from the START FREQ or STOP FREQ controls, respectively. These currents are summed at pin 3 of U4 together with a small current from the 1000:1 calibration adjustment. The +1 to +7 volts at the output of U4 is level shifted by Q1 to -11.5 to -6.5 volts at the bases of U7A, B, and C.

Ramp speed, and thus output frequency, is directly dependent on the amount of current through U7B. Linear or logarithmic negative feedback from the collector of U7B to the + input of U4 maintains dial linearity or creates the logarithmic response when in the LOG mode.

The current through U7A and C tracks that through U7B. U7C is the negative current source for the timing capacitor, while U7A is part of the current mirror for the positive current source (U7D).

Resistive current divider R18, R19, and R20 provides linear feedback from the collector of U7B to the + input of U4. This divider reduces the current applied to the + input of U4 while allowing the collector current of U7B to equal that of the negative current source of U7C. Equalizing these currents provides maximum precision by utilizing equal operating points.

When in LOG, the current divider is replaced with an active logarithmic amplifier consisting of Q206A and Q206B and FET Q205. As with the resistive current divider,

the current from U7A is equal to that of U7C, the negative current source, while the current to the + input of U4 is the much lower required value.

U7E acts as a current mirror; tracking is accomplished with negative feedback provided by Q5 and Q6. U7D provides the positive current source by matching the current in the current mirror.

The level detector alternately sinks each of the two current sources through diode bridge D11, D12, D13, and D14. Thus, as one source sends current to the detector, the remaining source linearly charges the range selected timing capacitor C15.

Q9, Q10, and Q11 are a unity gain buffer with a very high input impedance. This buffer prevents loading of the current sources to provide a very linear triangle. The input stage, FET Q9, is a source follower, and Q11 is an emitter follower.

The level detector-bistable switch, Q12, is a differential amplifier with Q13 providing a constant current. The reference levels, ± 5 volts, at the base of Q12B are determined by R53, R54, and R62, depending on the state of diode bridge D17 and D18. D15 and D16 limit the collector voltage excursions to maximize high frequency response.

The level detector collectors differentially drive a non-saturating current-mode switch, Q14 and Q15. One switch output, Q15, drives the level detector reference gate and the current source bridge. The output of Q14 is fed to the Q23-Q24 amplifier and used as the square wave output.

The SYNC OUTPUT signal is provided by Q17 and Q18. Q17 shifts the square wave to TTL levels and Q18 provides buffering.

Capacitance Multiplier

U8 is a capacitance multiplier used on the

1 Hz range only. It inverts and amplifies the triangle to ± 9 volts. This is applied to the opposite end of the $10 \mu\text{F}$ timing capacitor and makes it appear to be a $100 \mu\text{F}$ capacitor.

Sine Converter

The basic triangle wave is converted to a sine wave with a bipolar diode shaping network. The triangle is applied directly to the three diode bridges, D24, D25, and D26. As the triangle rises, each diode bridge switches in succession, causing the output of the network to form a sine wave.

Waveform Switches

These switches apply the appropriate waveform to the preamplifier. When TRIANGLE is selected, the basic triangle generated at C15 and buffered by Q9, Q10, and Q11 is used. The SQUARE position channels the square wave output of Q23-Q24 to the preamp. When SINE or HAVERSINE is chosen, the sine shaper output is sent through. HAVERSINE also changes the lockout level at the base of Q302, thus affecting the starting and stopping points of the sinusoidal waveform.

Preamplifier

The preamplifier is a non-inverting closed loop amplifier. Q25 and Q26 form the differential input stage providing dc stability. Q28 forms the second gain stage with Q27 providing the collector of Q28 with a high impedance for increased gain. Q29 buffers the second stage and is the output. Feedback is provided through R101.

Power Amplifier

The power amplifier works much like the preamplifier except that it is inverting and the second gain stage is buffered by Q34 and Q35 prior to the output stage Q36 and Q37.

Lockout

Lockout is used to gate the 3025 in response to a signal from the TRIG INPUT jack or the MAN switch. The generator is stopped, or locked out, by removing the timing

current from capacitor C15. Q302 and Q303 form a differential amplifier with the voltage at the base of Q302 being the lockout voltage. The base of Q303 is connected to the output of the triangle buffer. When the triangle reaches the lockout voltage, Q303 is turned on and the timing current is taken away from the capacitor. The lockout voltage is set by R302 to approximately 0 volts dc.

Q301 is a current source tracking the positive current source, keeping the lockout level at the same voltage independent of timing current.

Lockout is disabled by pulling the emitters of Q302 and Q303 to 0 volts. This is done by the lockout flip-flop U302C and D. This is a set-reset type flip-flop receiving signals from the trigger comparator and the level detector to enable and disable lockout.

U303 is the trigger comparator. It is a differential comparator set to switch at 1.4 volts with 100 mV of hysteresis. This shapes the incoming trigger signals to levels suitable to drive the flip-flop. U302A and B form a switch debouncer for the manual trigger switch.

The action of U302C and D and the level setting of R302 permits the waveform to always complete a full cycle before lockout occurs. In the case of haversines, waveform selection automatically switches the lockout level to the minimum value of the sine wave.

Sweep

The ramp used for sweeping is generated by integrator U201 and level detector U202. The integrating current is supplied by R206 from the SWEEP TIME control. Reset current is supplied by R207. U202 senses when the ramp reaches 5 volts and switches to turn on the reset current which rapidly returns the ramp to 0 volts. U202 senses this voltage change and switches again. The ramp peak voltage is set by Q202.

Power Supplies

The ± 20 volt unregulated supplies for the

the power amplifier are generated from transformer T1, full wave bridge D1 through D4 and filter capacitors C1 and C2. The ± 12 volt

regulated supplies are composed of regulators U1 and U2, which regulate the ± 20 volt supplies down to ± 12 volts.

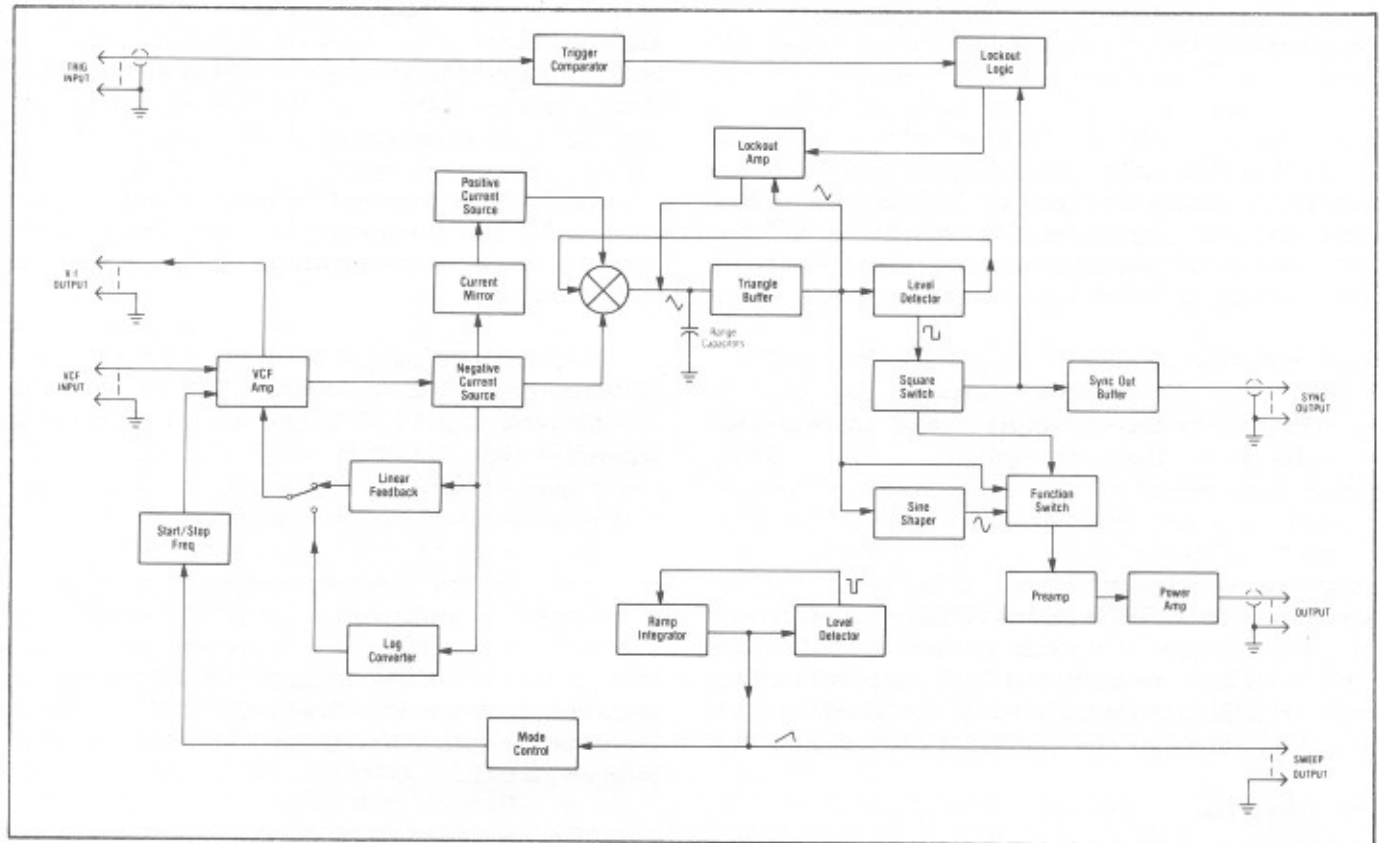

Fig. 12. Block Diagram.

MAINTENANCE AND CALIBRATION

WARNING

1. The following instructions are for use by qualified personnel only. To avoid electric shock, do not perform servicing other than contained in the operating instructions unless you are qualified to do so.
2. A shock hazard is present when the case is removed once the line cord is plugged into an ac outlet. Avoid touching the fuse or bottom of the circuit board in the area of the fuse or power transformer. The fuse has line voltage on it even when the power is turned off.

LINE VOLTAGE SELECTION

The unit is capable of operating from nominal 100 volt, 120 volt, 220 volt, or 240 volt, 50/60 Hz ac power.

The LINE VOLTAGE SELECT switches on the bottom of the case are simply set to the positions that correspond with the line voltage to be used. Insert a flat blade screwdriver into the slot of each switch and move the slots to align with the graphics indicating the desired voltage (see Fig. 13).

Install correct value fuse, as follows:

100/120 volt ac
operation: 3AG,
1/4 A Slow Blow

220/240 volt ac
operation: 3AG,
1/8 A Slow Blow

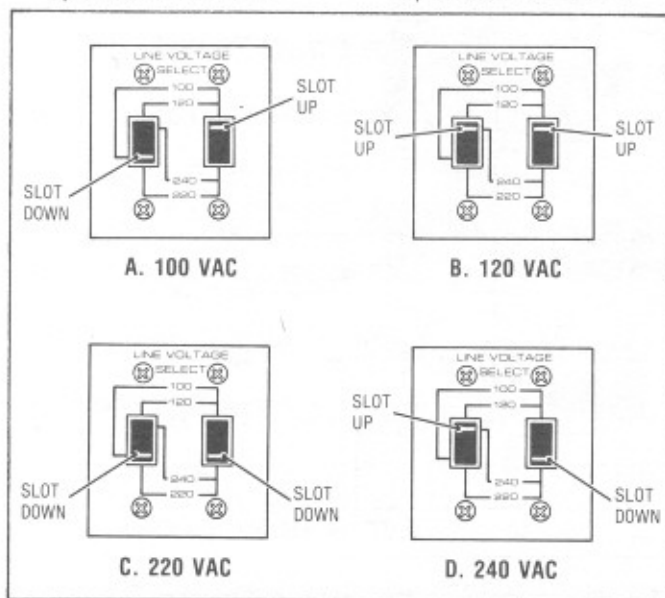

Fig. 13. Line voltage selection.

CALIBRATION ADJUSTMENTS

This unit was carefully checked and calibrated at the factory prior to shipment. Readjustment is recommended only if repairs have been made in a circuit affecting calibration, or if you have reason to believe the unit may be out of calibration. Complete recalibration procedures are given in this manual. However, calibration adjustments should be attempted only if the proper test equipment is available, and you are experienced and qualified in its use. If the accuracy of the test equipment used for calibration is less than specified, the accuracy of the 3025 will be proportionately degraded. Perform related adjustments in the specified sequence to avoid any undesirable interaction of adjustments. Locations of calibration adjustments are given in Fig. 14.

TEST EQUIPMENT REQUIRED

Oscilloscope, dc-35 MHz, risetime 12 ns or less, vertical sensitivity 10 mV per division, **B & K-Precision** Model 1479B or equivalent.

Counter-timer, 1 Hz to 5 MHz with time interval A to B.

Distortion Analyzer, less than 0.1% residual distortion.

PROCEDURE

Initial Control Settings

Set the front panel controls as follows:

LIN/LOG	Disengaged
RUN	Engaged
GATE	Disengaged
RANGE-Hz	10K
SWEEP RUN	Disengaged
SWEEP STOP	Disengaged
STOP FREQ	Midrange
WAVEFORM	SQUARE
DC OFFSET	OFF
AMPLITUDE	Fully clockwise

Time Symmetry Adjustment

1. Connect HI OUTPUT to frequency counter.
2. Set counter to measure time interval.
3. Set START FREQ for a reading of approximately 15 μ s.
4. Alternately switch the counter-timer to measure the two halves of the waveform separately (positive edge to negative edge, then negative to positive).
5. Adjust TOP SYM for both halves to be the same $\pm 0.1\%$ (± 15 ns).
6. Set START FREQ for a counter reading

Buffer Offset Adjustment

1. Connect oscilloscope to TP1.
2. Adjust BUF DC for a symmetrical triangle around 0 V ± 100 mV.

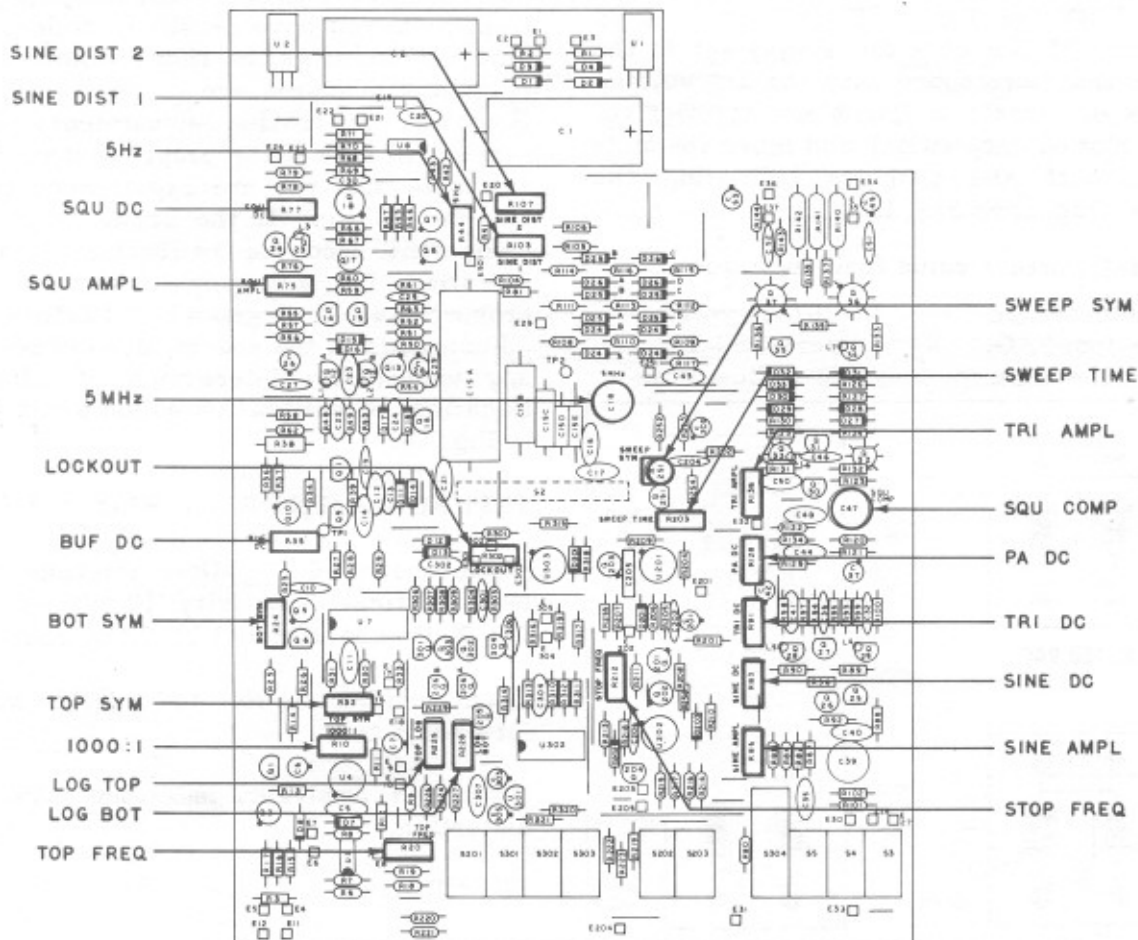

Fig. 14. Calibration adjustment locations.

of approximately 5 ms. If dial will not adjust low enough in period, Vary 1000:1 Do not change ranges.

7. Adjust BOT SYM as in steps 4 and 5 above.
8. Repeat steps 3 through 7 until no further improvement can be obtained.

Frequency Adjustment

1. Set START FREQ fully counterclockwise; set RANGE-Hz to 10K.
2. Set counter to measure frequency (or period for low frequency adjustments).
3. Adjust 1000:1 for a frequency of 40 Hz ± 4 Hz (25 ms ± 2.5 ms).
4. Set START FREQ for a counter reading of 5 kHz. The dial should now be set at .5 on the LIN scale (5 minor divisions below 1). If not, adjust by loosening the set screws on the dial and rotating it.
5. Set START FREQ to 5.
6. Adjust TOP FREQ for 50 kHz.
7. Repeat steps 4 through 6 until both readings are within 1%.
8. Set START FREQ to 5.
9. Set RANGE-Hz to 1.
10. Adjust 5 Hz for 5 Hz ± 0.5 Hz (200 ms ± 2 ms).
11. Set RANGE-Hz to 1M.
12. Adjust 5 MHz for 5 MHz ± 50 kHz.

Log Scale Adjustment

1. Depress LOG.
2. Set RANGE-Hz to 10K.
3. Adjust LOG TOP for 50 kHz ± 500 Hz (20 μ s ± 0.2 μ s).

4. Turn START FREQ fully counterclockwise.
5. Adjust LOG BOT for 4 Hz ± 0.4 Hz (250 ms ± 25 ms).
6. Repeat steps 3 through 5 until no more improvement can be obtained.
7. Disengage LOG.

Sine Wave Distortion

1. Set waveform to SINE.
2. Set RANGE-Hz to 10K.
3. Set START FREQ to 5.
4. Connect HI OUTPUT to distortion analyzer.
5. Adjust SINE DIST 1 and SINE DIST 2 for minimum distortion. Repeat until no more improvement can be obtained.

Output Level Adjustment

1. Connect HI OUTPUT to oscilloscope terminated in 50 Ω .
2. Turn AMPLITUDE fully counterclockwise.
3. Adjust PA DC for 0 V dc ± 10 mV.
4. Set waveform to TRIANGLE.
5. Turn AMPLITUDE fully clockwise.
6. Adjust TRI DC for a dc offset of 0 V ± 10 mV.
7. Adjust TRI AMPL for triangle peaks of +5.1 V and -5.1 V ± 50 mV.
8. Set waveform to SINE.
9. Adjust SINE DC for a dc offset of 0 V ± 10 mV.
10. Adjust SINE AMPL for sine peaks of +5.1 V and -5.1 V ± 50 mV.

11. Set waveform to SQUARE.
12. Adjust SQU DC for positive square wave peaks of $+5.1\text{ V} \pm 50\text{ mV}$.
13. Adjust SQU AMPL for negative square wave peaks of $-5.1\text{ V} \pm 50\text{ mV}$.

Rise Time Adjustment

1. Set START FREQ to 3.
2. Set RANGE-Hz to 1 M.
3. Adjust SQU COMP for rise and fall times less than 50 ns and overshoot and ringing less than 5%.

Start Level Adjustment

1. Set waveform switch to TRIANGLE.
2. Disengage RUN.
3. Adjust LOCKOUT for $0\text{ V} \pm 50\text{ mV}$.

Sweep Adjustment

1. Engage RUN.
2. Engage SWEEP RUN.
3. Engage SWEEP STOP.
4. Adjust STOP FREQ for minimum change in frequency as START FREQ is rotated.
5. Disengage SWEEP STOP.

Sweep Time Adjustment

1. Connect oscilloscope to SWEEP OUTPUT, unterminated.
2. Turn SWEEP TIME (front panel) fully clockwise.
3. Turn SWEEP TIME (calibration adjustment) fully counterclockwise, then turn it back until the ramp just stops.

WARRANTY INFORMATION

WARRANTY SERVICE INSTRUCTIONS

1. Refer to the MAINTENANCE section of your **B & K-Precision** instruction manual for adjustments that may be applicable.
2. If the above-mentioned does not correct the problem you are experiencing with your unit, pack it securely (preferably in the original carton or double-packed). Enclose a letter describing the problem and include your name and address. Deliver to, or ship PREPAID (UPS preferred) to the nearest **B & K-Precision** authorized service agency (see list enclosed with unit).

If your list of authorized **B & K-Precision** service agencies has been misplaced, contact your distributor for the name of your nearest service agency, or write to:

Service Department
B & K-Precision Product Group
DYNASCAN CORPORATION
2815 West Irving Park Road
Chicago, Illinois 60618

LIMITED ONE-YEAR WARRANTY

DYNASCAN CORPORATION warrants to the original purchaser that its **B & K-Precision** product, and the component parts thereof, will be free from defects in workmanship and materials for a period of one year from the date of purchase.

DYNASCAN will, without charge, repair or replace, at its option, defective product or component parts upon delivery to an authorized **B & K-Precision** service contractor or the factory service department, accompanied by proof of purchase date in the form of a sales receipt.

To obtain warranty coverage, this product must be registered by completing and mailing the enclosed warranty registration card to DYNASCAN, **B & K-Precision**, 6460 West Cortland Street, Chicago, Illinois 60635 within fifteen (15) days from the date of purchase.

Exclusions: This warranty does not apply in the event of misuse or abuse of the product or as a result of unauthorized alterations or repairs. It is void if the serial number is altered, defaced or removed.

DYNASCAN shall not be liable for any consequential damages, including without limitation damages resulting from loss of use. Some states do not allow limitation of incidental or consequential damages, so the above limitation or exclusion may not apply to you.

This warranty gives you specific rights and you may also have other rights which vary from state to state.

For your convenience we suggest you contact your **B & K-Precision** distributor, who may be authorized to make repairs or can refer you to the nearest service contractor. If warranty service cannot be obtained locally, please send the unit to **B & K-Precision** Service Department, 2815 West Irving Park Road, Chicago, Illinois 60618, properly packaged to avoid damage in shipment.

ACCESSORIES

ACCESSORIES SUPPLIED

Power Cord

Instruction Manual

Composite (Schematic and Parts List)

OPTIONAL ACCESSORIES AVAILABLE:

B & K-Precision Cables:

Model	Description
CC-41	36" RG/58U coax, BNC on each end.
CC-42	36" RG/58U coax, BNC to UHF (PL-259)
CC-43	36" RG/58U coax, BNC to dual banana plugs.
CC-44	36" RG/58U coax, BNC to microphone connector.
CC-45	36" RG/58U coax, BNC to type N.

SCHEMATIC DIAGRAM and PARTS LIST ADDENDUM

for

Model 3025 SWEEP/FUNCTION GENERATOR

A product change has been incorporated into the Model 3025 Sweep/Function Generator since the printing of your instruction manual and parts list. This addendum itemizes those changes.

The mechanical design of the case and handle assembly has been changed, along with a color change of knobs and bezel from black to tan. A complete list of replacement parts follows for both designs; use the list that applies to your unit.

UNITS WITH TAN TRIM

Knob, Tan (4 used)	751-237-9-001
Knob, RANGE Switch, Tan	751-238-9-001
START FREQ Dial/Knob, Tan	751-236-9-001
Pushbutton, Tan (10 used) . .	384-038-9-017
Case, Top	253-107-9-001
Case, Bottom	252-044-9-001
Case, Side Panel Assembly, Left or Right	523-479-9-001
Front Panel	255-213-9-001
Rear Panel	262-041-9-001
Bezel Assembly, Tan, Front or Rear	539-125-0-000
Bezel, L.E.D.	380-463-9-001
Handle Assembly	539-113-0-000
Hub, Detent	746-062-9-001
Spring, Handle	767-118-9-001
Washer, Flat (Retainer for Handle Spring)	725-040-3-210
Screw, #6 x 1/2" Dulite (2 used, Secure Handle Washer) . .	706-916-1-901
Bracket, PCB Mounting	251-559-9-001

UNITS WITH BLACK TRIM

Knob, Black (4 used)	751-216-9-001
Knob, RANGE Switch, Black	751-220-9-001
START FREQ Dial/Knob Assembly, Black	523-428-9-001
Pushbutton, Black (10 used). .	384-038-9-001
Case, Top	253-100-9-001
Case, Bottom	252-042-9-001
Case, Side Panel, Left or Right	263-011-9-001
Front Panel	255-213-9-001
Rear Panel	262-041-9-001
Bezel, Black, Front or Rear	260-315-9-001
Bezel, L.E.D.	380-463-9-001
Handle Arm	746-056-9-001
Handle Grip Assembly	523-431-9-001
Handle Lock Button	746-057-9-001
Handle Mounting Plate	746-058-9-001
Spring, Handle	767-108-9-001
Plastic Washer, for handle . .	347-103-9-001
Flat Washer, for handle	720-024-1-206

BK PRECISION DYNASCAN
CORPORATION

6460 West Cortland Street
Chicago, Illinois 60635

© 1981 • DYNASCAN CORP.



CIRCUIT ANALYSIS

the power amplifier are generated from transformer T1, full wave bridge D1 through D4 and filter capacitors C1 and C2. The ± 12 volt

regulated supplies are composed of regulators U1 and U2, which regulate the ± 20 volt supplies down to ± 12 volts.

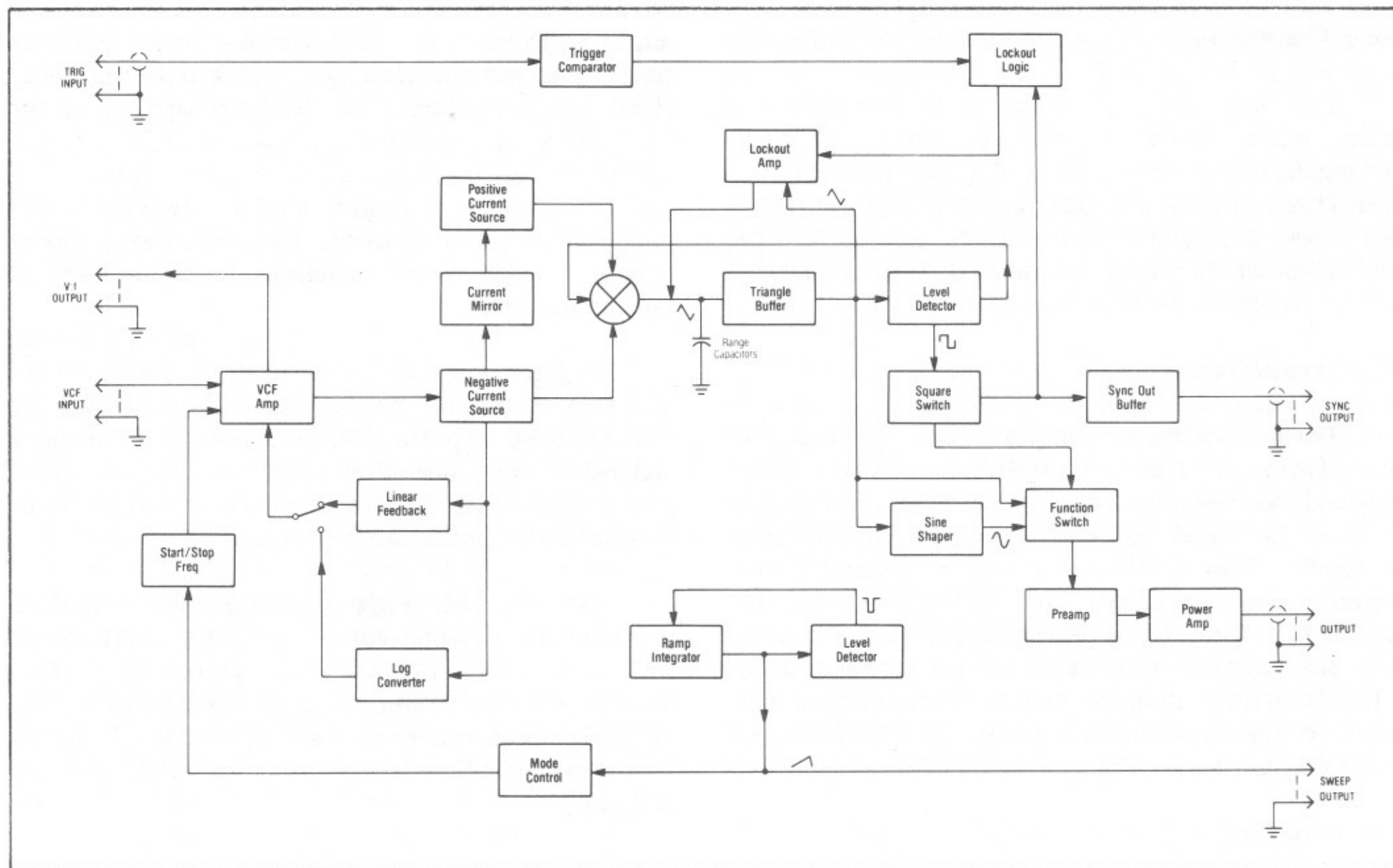

Fig. 12. Block Diagram.

triangle around 0 V \pm 100 mV.

6. Set START FREQ for a counter reading

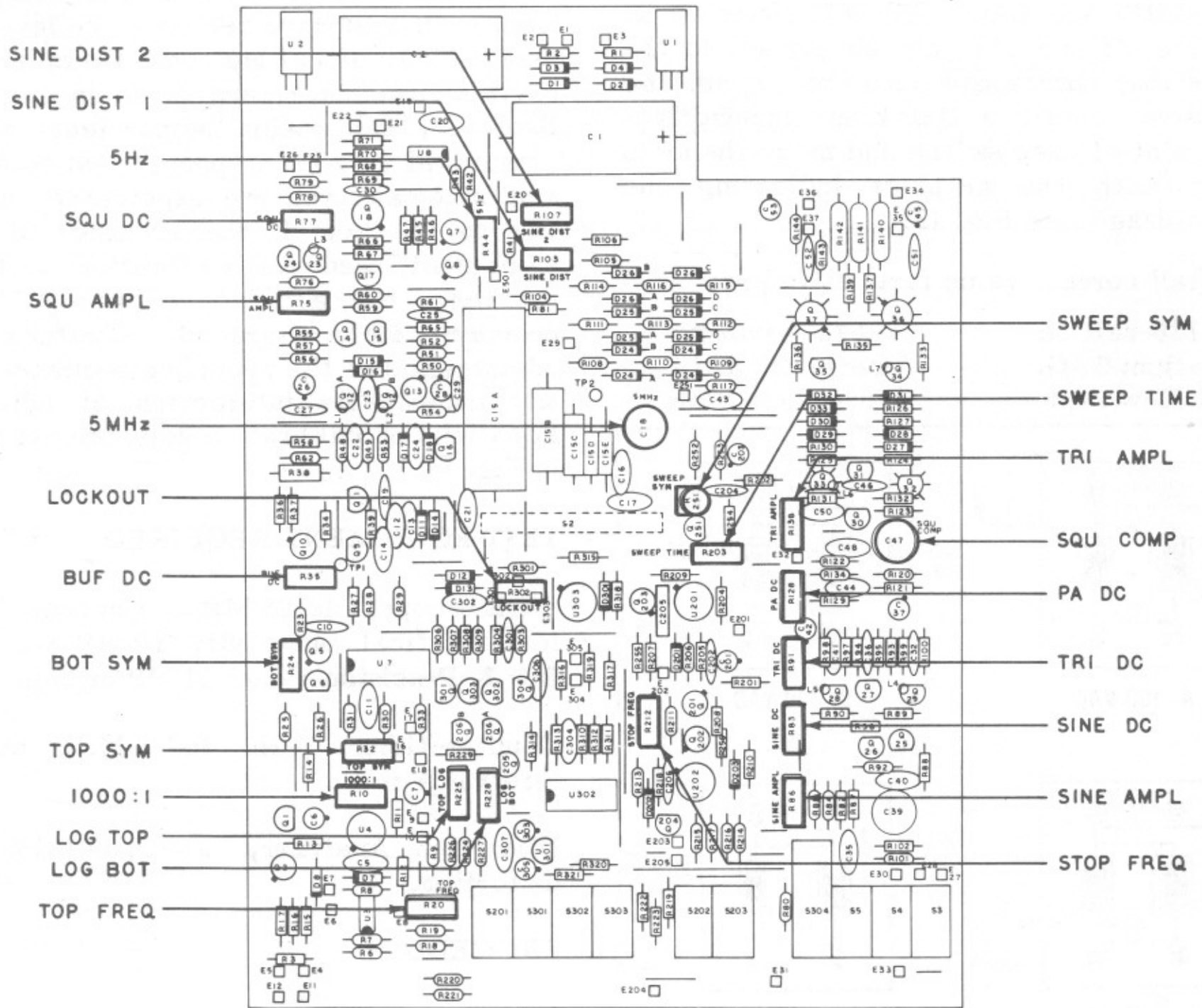

Fig. 14. Calibration adjustment locations.