

# Micropower Thermocouple Cold Junction Compensator

## FEATURES

- 80 $\mu$ A Supply Current
- 4V to 36V Operation
- 0.5 $^{\circ}$ C Initial Accuracy (A Version)
- Compatible with Standard Thermocouples (E, J, K, R, S, T)
- Auxiliary 10mV/ $^{\circ}$ C Output
- Available in 8-Lead PDIP and SO Packages

## APPLICATIONS

- Thermocouple Cold Junction Compensator
- Centigrade Thermometer
- Temperature Compensation Network

## DESCRIPTION

The LT<sup>®</sup>1025 is a micropower thermocouple cold junction compensator for use with type E, J, K, R, S, and T thermocouples. It utilizes wafer level and post-package trimming to achieve 0.5 $^{\circ}$ C initial accuracy. Special curvature correction circuitry is used to match the “bow” found in all thermocouples so that accurate cold junction compensation is maintained over a wider temperature range.

The LT1025 will operate with a supply voltage from 4V to 36V. Typical supply current is 80 $\mu$ A, resulting in less than 0.1 $^{\circ}$ C internal temperature rise for supply voltages under 10V. A 10mV/ $^{\circ}$ C output is available at low impedance, in addition to the direct thermocouple voltages of 60.9 $\mu$ V/ $^{\circ}$ C (E), 51.7 $\mu$ V/ $^{\circ}$ C (J), 40.3 $\mu$ V/ $^{\circ}$ C (K, T) and 5.95 $\mu$ V/ $^{\circ}$ C (R, S). All outputs are essentially independent of power supply voltage.

A special kit is available (LTK001) which contains an LT1025 and a custom tailored thermocouple amplifier. The amplifier and compensator are matched to allow a much tighter specification of temperature error than would be obtained by adding the compensator and amplifier errors on a worst-case basis. The amplifier from this kit is available separately as LTKA0x.

The LT1025 is available in either an 8-pin PDIP or 8-pin SO package for temperatures between 0 $^{\circ}$ C and 70 $^{\circ}$ C.

 LTC and LT are registered trademarks of Linear Technology Corporation.

## BLOCK DIAGRAM

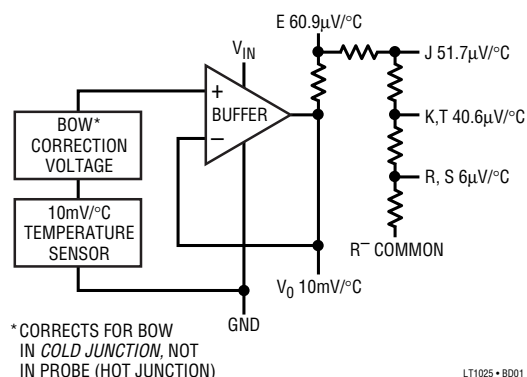

## TYPICAL APPLICATION

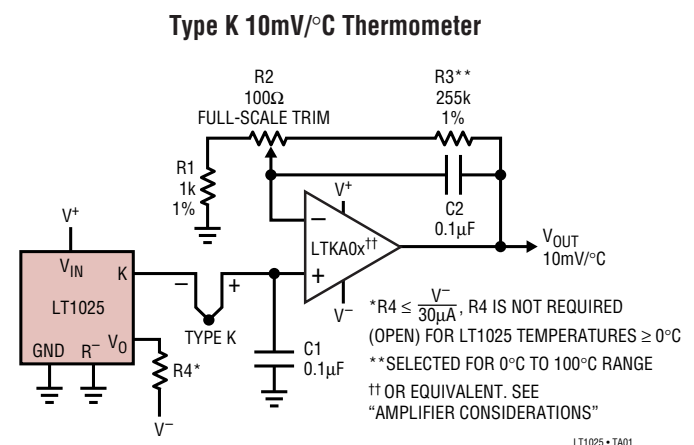

# LT1025

## ABSOLUTE MAXIMUM RATINGS

(Note 1)

Input Supply Voltage .....	36V
Output Voltage (Forced) .....	5V
Output Short-Circuit Duration .....	Indefinite
Operating Temperature Range	
LT1025AC, LT1025C .....	0°C to 70°C
LT1025AM, LT1025M .....	-55°C to 125°C
Storage Temperature Range .....	-55°C to 150°C

## PACKAGE/ORDER INFORMATION

N8 PACKAGE 8-LEAD PDIP  
 $T_{JMAX} = 150^{\circ}\text{C}$ ,  $\theta_{JA} = 130^{\circ}\text{C/W}$  (N8)  
 $T_{JMAX} = 150^{\circ}\text{C}$ ,  $\theta_{JA} = 190^{\circ}\text{C/W}$  (S8)

S8 PACKAGE 8-LEAD PLASTIC SO

J8 PACKAGE 8-LEAD CERDIP  
 $T_{JMAX} = 150^{\circ}\text{C}$ ,  $\theta_{JA} = 100^{\circ}\text{C/W}$

**OBSOLETE PACKAGE**  
 Consider the N8 Package for Alternate Source

ORDER PART NUMBER	LT1025ACN8 LT1025CN8 LT1025CS8
S8 PART MARKING	1025
	LT1025AMJ8 LT1025MJ8

Consult LTC Marketing for parts specified with wider operating temperature ranges.

## ELECTRICAL CHARACTERISTICS

The ● denotes the specifications which apply over the full operating temperature range, otherwise specifications are at  $T_A = 25^{\circ}\text{C}$ .  $V_S = 5\text{V}$ , Pin 5 tied to Pin 4, unless otherwise noted.

PARAMETER	CONDITIONS	MIN	TYP	MAX	UNITS		
Temperature Error at 10mV/°C Output (Notes 4, 5)	$T_J = 25^{\circ}\text{C}$ LT1025A		0.3	0.5	°C		
	LT1025		0.5	2.0	°C		
	Full Temperature Span	●	See Curve				
Resistor Divider Accuracy (Notes 2, 4)	$V_{OUT} = 10\text{mV}/^{\circ}\text{C}$ LT1025A	E	60.6	60.9	61.3	µV/°C	
		J	51.4	51.7	52.1	µV/°C	
	LT1025	K, T	40.3	40.6	41.0	µV/°C	
		R, S	5.8	5.95	6.2	µV/°C	
	Supply Current	$4\text{V} \leq V_{IN} \leq 36\text{V}$ LT1025AC, LT1025C LT1025AM, LT1025M	E	50	80	100	µA
			J	50		150	µA
K, T					200	µA	
R, S						µA	
Line Regulation (Note 3)	$4\text{V} \leq V_{IN} \leq 36\text{V}$	●	0.003	0.02	°C/V		
Load Regulation (Note 3)	$0 \leq I_O \leq 1\text{mA}$	●	0.04	0.2	°C		
Divider Impedance	E	J		2.5		kΩ	
		K, T		2.1		kΩ	
		R, S		4.4		kΩ	
				3.8		kΩ	
						kΩ	
Change in Supply Current	$4\text{V} \leq V_{IN} \leq 36\text{V}$		0.01	0.05	µA/V		

**Note 1:** Absolute Maximum Ratings are those values beyond which the life of a device may be impaired.

**Note 2:** Divider accuracy is measured by applying a 10.000V signal to the output divider and measuring the individual outputs.

**Note 3:** Regulation does not include the effects of self-heating. See "Internal Temperature Rise" in Application Guide. Load regulation is  $30\mu\text{A} \leq I_O \leq 1\text{mA}$  for  $T_A \leq 0^{\circ}\text{C}$ .

**Note 4:** To calculate total temperature error at individual thermocouple outputs, add 10mV/°C output error to the resistor divider error. Total error for type K output at 25°C with an LT1025A is  $0.5^{\circ}\text{C}$  plus  $(0.4\mu\text{V}/^{\circ}\text{C})(25^{\circ}\text{C})/(40.6\mu\text{V}/^{\circ}\text{C}) = 0.5^{\circ}\text{C} + 0.25^{\circ}\text{C} = 0.75^{\circ}\text{C}$ .

**Note 5:** Temperature error is defined as the deviation from the following formula:  $V_{OUT} = 10\text{mV}(T) + (10\text{mV})(5.5 \cdot 10^{-4})(T - 25^{\circ}\text{C})^2$ . The second term is a built-in nonlinearity designed to help compensate the nonlinearity of the cold junction. This "bow" is  $\approx 0.34^{\circ}\text{C}$  for a 25°C temperature change.

1025fb

## TYPICAL PERFORMANCE CHARACTERISTICS

10mV/°C Output Temperature Error LT1025

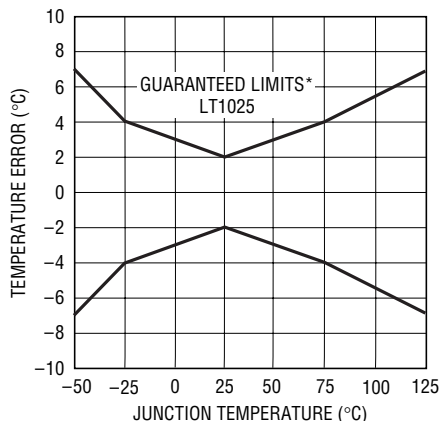

LT1025 • G01

\*ERROR CURVE FACTORS IN THE NONLINEARITY TERM BUILT IN TO THE LT1025. SEE THEORY OF OPERATION IN APPLICATION GUIDE SECTION

10mV/°C Output Temperature Error LT1025A

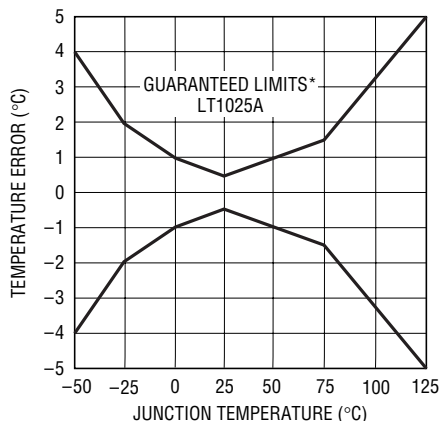

LT1025 • G02

\*ERROR CURVE FACTORS IN THE NONLINEARITY TERM BUILT IN TO THE LT1025. SEE THEORY OF OPERATION IN APPLICATION GUIDE SECTION

Supply Current

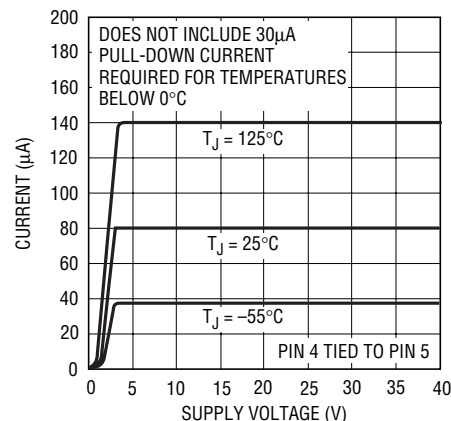

LT1025 • G03

## APPLICATIONS INFORMATION

The LT1025 was designed to be extremely easy to use, but the following ideas and suggestions should be helpful in obtaining the best possible performance and versatility from this new cold junction compensator.

### Theory of Operation

A thermocouple consists of two dissimilar metals joined together. A voltage (Seebeck EMF) will be generated if the two ends of the thermocouple are at different temperatures. In Figure 1, iron and constantan are joined at the temperature measuring point T1. Two additional thermocouple junctions are formed where the iron and constantan connect to ordinary copper wire. For the purposes of this discussion it is assumed that these two junctions are at the same temperature, T2. The Seebeck voltage, V<sub>S</sub>, is the product of the Seebeck coefficient α, and the temperature difference, T1 – T2; V<sub>S</sub> = α (T1 – T2). The junctions at T2 are commonly called the cold junction because a common practice is to immerse the T2 junction in 0°C ice/water slurry to make T2 independent of room temperature variations. Thermocouple tables are based on a cold-junction temperature of 0°C.

To date, IC manufacturers efforts to make microminiature thermos bottles have not been totally successful. Therefore, an electronically simulated cold-junction is required for most applications. The idea is basically to add a temperature dependent voltage to V<sub>S</sub> such that the voltage sum is the same as if the T2 junction were at a constant 0°C instead of at room temperature. This voltage source is called a cold junction compensator. Its output is designed to be 0V at 0°C and have a slope equal to the Seebeck coefficient over the expected range of T2 temperatures.

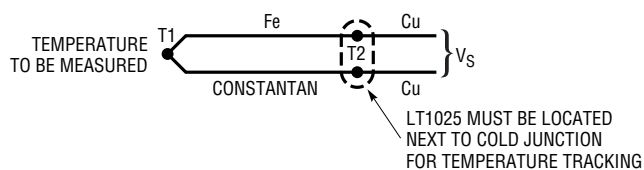

LT1025 • AG01

Figure 1

To operate properly, a cold junction compensator must be at exactly the same temperature as the cold junction of the thermocouple (T2). Therefore, it is important to locate the LT1025 physically close to the cold junction with local temperature gradients minimized. If this is not possible,

## APPLICATIONS INFORMATION

an extender made of matching thermocouple wire can be used. This shifts the cold junction from the user termination to the end of the extender so that the LT1025 can be located remotely from the user termination as shown in Figure 2.

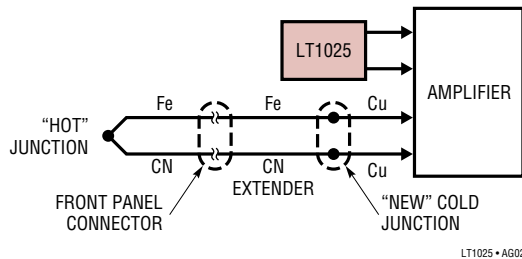

Figure 2

The four thermocouple outputs on the LT1025 are 60.9μV/°C (E), 51.7μV/°C (J), 40.6μV/°C (K and T), and 6μV/°C (R and S). These particular coefficients are chosen to match the room temperature (25°C) slope of the thermocouples. Over wide temperature ranges, however, the slope of thermocouples changes, yielding a quasi-parabolic error compared to a constant slope. The LT1025 outputs have a deliberate parabolic “bow” to help compensate for this effect. The outputs can be mathematically described as the sum of a linear term equal to room temperature slope plus a quadratic term proportional to temperature deviation from 25°C *squared*. The coefficient (β) of the quadratic term is a compromise value chosen to offer improvement in all the outputs.

$$V_{OUT} = \alpha T + \alpha\beta(T - 25^\circ)^2$$

$$\beta \approx 5.5 \cdot 10^{-4}$$

The actual β term which would be required to best compensate each thermocouple type in the temperature range of 0°C to 50°C is: E, 6.6 · 10<sup>-4</sup>; J, 4.8 · 10<sup>-4</sup>; K, 4.3 · 10<sup>-4</sup>; R, 1.9 · 10<sup>-3</sup>; S, 1.9 · 10<sup>-3</sup>; T, 1 · 10<sup>-3</sup>.

*The temperature error specification for the LT1025 10mV/°C output (shown as a graph) assumes a β of 5.5 · 10<sup>-4</sup>. For example, an LT1025 is considered “perfect” if its 10mV/°C output fits the equation  $V_O = 10mV(T) + (10mV)(5.5 \cdot 10^{-4})(T - 25^\circ C)^2$ .*

### Operating at Negative Temperatures

The LT1025 is designed to operate with a single positive supply. It therefore cannot deliver proper outputs for

temperatures below zero unless an external pull-down resistor is added to the V<sub>O</sub> output. This resistor can be connected to any convenient negative supply. It should be selected to sink at least 30μA of current. Suggested value for a -5V supply is 150kΩ, and for a -15V supply, 470kΩ. Smaller resistors must be used if an external load is connected to the 10mV/°C output. The LT1025 can source up to 1mA of current, but there is a trade-off with internal temperature rise.

### Internal Temperature Rise

The LT1025 is specified for temperature accuracy assuming no internal temperature rise. At low supply voltages this rise is usually negligible (≈ 0.05°C at 5V), but at higher supply voltages or with external loads or pull-down current, internal rise could become significant. This effect can be calculated from a simple thermal formula, ΔT = (θ<sub>JA</sub>)(V<sup>+</sup>)(I<sub>Q</sub> + I<sub>L</sub>), where θ<sub>JA</sub> is thermal resistance from junction to ambient, (≈ 130°C/W), V<sup>+</sup> is the LT1025 supply voltage, I<sub>Q</sub> is the LT1025 supply current (≈ 80μA) and I<sub>L</sub> is the total load current including actual load to ground and any pull-down current needed to generate negative outputs. A sample calculation with a 15V supply and 50μA pull-down current would yield, (130°C/W) (15V) (80μA + 50μA) = 0.32°C. This is a significant rise in some applications. It can be reduced by lowering supply voltage (a simple fix is to insert a 10V zener in the V<sub>IN</sub> lead) or the system can be calibrated and specified after an initial warm-up period of several minutes.

### Driving External Capacitance

The direct thermocouple drive pins on the LT1025 (J, K, etc.) can be loaded with as much capacitance as desired, but the 10mV/°C output should not be loaded with more than 50pF unless external pull-down current is added, or a compensation network is used.

### Thermocouple Effects in Leads

Thermocouple voltages are generated whenever dissimilar materials are joined. **This includes the leads of IC packages**, which may be kovar in TO-5 cans, alloy 42 or copper in dual-in-line packages, and a variety of other materials in plating finishes and solders. The net effect of these thermocouples is “zero” if all are at exactly the

## APPLICATIONS INFORMATION

same temperature, but temperature gradients exist within IC packages and across PC boards whenever power is dissipated. For this reason, extreme care must be used to ensure that no temperature gradients exist in the vicinity of the thermocouple terminations, the LT1025, or the thermocouple amplifier. If a gradient cannot be eliminated, leads should be positioned isothermally, especially the LT1025  $R^-$  and appropriate output pins, the amplifier input pins, and the gain setting resistor leads. An effect to watch for is amplifier offset voltage warm-up drift caused by mismatched thermocouple materials in the wire-bond/lead system of the IC package. This effect can be as high as tens of microvolts in TO-5 cans with kovar leads. It has nothing to do with the actual offset drift specification of the amplifier and can occur in amplifiers with measured “zero” drift. Warm-up drift is directly proportional to amplifier power dissipation. It can be minimized by avoiding TO-5 cans, using low supply current amplifiers, and by using the lowest possible supply voltages. Finally, it can be accommodated by calibrating and specifying the system after a five minute warm-up period.

### Reversing the Polarity of the 10mV/°C Output

The LT1025 can be made to “stand on its head” to achieve a minus 10mV/°C output point. This is done as shown in Figure 3. The normal output ( $V_O$ ) is grounded and feedback is established between the ground pin and the positive supply pin by feeding both of them with currents while coupling them with a 6V zener. The ground pin will

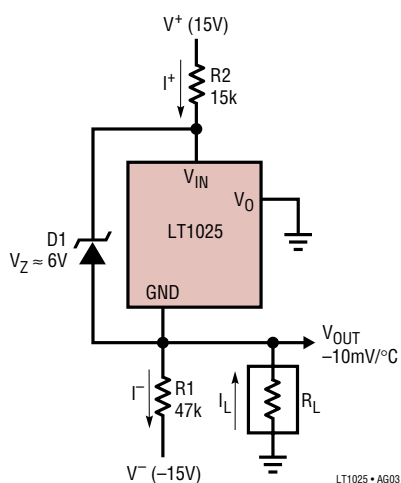

Figure 3

now be forced by feedback to generate  $-10\text{mV}/^\circ\text{C}$  as long as the grounded output is supplying a net “source” current into ground. This condition is satisfied by selecting  $R1$  such that the current through  $R1$  ( $I^-$ ) is more than the sum of the LT1025 supply current, the maximum load current ( $I_L$ ), and the minimum zener current ( $\approx 50\mu\text{A}$ ).  $R2$  is then selected to supply more current than  $I^-$ .

$$R1 = \frac{V^-}{300\mu\text{A} + I_L}, \quad R2 = \frac{V^+ - V_Z (\approx 6\text{V})}{V^-/R1 + 280\mu\text{A}}$$

For  $\pm 15\text{V}$  supplies, with  $I_L = 20\mu\text{A}$  maximum,  $R1 = 47\text{k}$  and  $R2 = 15\text{k}$ .

### Amplifier Considerations

Thermocouple amplifiers need very low offset voltage and drift, and fairly low bias current if an input filter is used. The best precision bipolar amplifiers should be used for type J, K, E, and T thermocouples which have Seebeck coefficients of  $40\mu\text{V}/^\circ\text{C}$  to  $60\mu\text{V}/^\circ\text{C}$ . In particularly critical applications or for R and S thermocouples ( $6\mu\text{V}/^\circ\text{C}$  to  $15\mu\text{V}/^\circ\text{C}$ ), a chopper-stabilized amplifier is required. Linear Technology offers three amplifiers specifically tailored for thermocouple applications. The LTKA0x is a bipolar design with extremely low offset ( $< 35\mu\text{V}$ ), low drift ( $< 1.5\mu\text{V}/^\circ\text{C}$ ), very low bias current ( $< 1\text{nA}$ ), and almost negligible warm-up drift (supply current is  $\approx 400\mu\text{A}$ ). It is very cost effective even when compared with “jellybean” op amps with vastly inferior specifications.

For the most demanding applications, the LTC1050 and LTC1052 CMOS chopper-stabilized amplifiers offer  $5\mu\text{V}$  offset and  $0.05\mu\text{V}/^\circ\text{C}$  drift (even over the full military temperature range). Input bias current is  $30\text{pA}$ , and gain is typically 30 million. These amplifiers should be used for R and S thermocouples, especially if no offset adjustments can be tolerated, or a large ambient temperature swing is expected.

Regardless of amplifier type, it is suggested that for best possible performance, dual-in-line (DIP) packages be used to avoid thermocouple effects in the kovar leads of TO-5 metal can packages if amplifier supply current exceeds  $500\mu\text{A}$ . These leads can generate both DC and AC offset terms in the presence of thermal gradients in the package and/or external air motion.

## APPLICATIONS INFORMATION

In many situations, thermocouples are used in high noise environments, and some sort of input filter is required. (See discussion of input filters). To reject 60Hz pick-up with reasonable capacitor values, input resistors in the 10k-100k range are needed. Under these conditions, bias current for the amplifier needs to be less than 1nA to avoid offset and drift effects.

To avoid gain error, high open loop gain is necessary for single-stage thermocouple amplifiers with 10mV/°C or higher outputs. A type K amplifier, for instance, with 100mV/°C output, needs a *closed* loop gain of ≈2,500. An ordinary op amp with a minimum open loop of 50,000 would have an initial gain error of (2,500)/(50,000) = 5%! Although closed loop gain is commonly trimmed, temperature drift of open loop gain will have a very deleterious effect on output accuracy. Minimum suggested open loop gain for type E, J, K, and T thermocouples is 250,000. This gain is adequate for type R and S if output scaling is 10mV/°C or less.

### Suggested Amplifier Types

THERMOCOUPLE	SUPPLY VOLTAGE		
	±15V	±5V	SINGLE SUPPLY
E, J, K, T	LTKA0x LT1012 LT1001	LTKA0x LT1012 LT1001 LTC1050 LTC1052 LT1006	LTC1050 LTC1052 LT1006
R, S	LTKA0x LT1012	LTC1050 LTC1052 LTKA0x	LTC1050 LTC1052 LT1006

### Thermocouple Nonlinearities

Thermocouples are linear over relatively limited temperature spans if accuracies of better than 2°C are needed. The graph in Figure 4 shows thermocouple nonlinearity for the temperature range of 0°C to 400°C. Nonlinearities can be dealt with in hardware by using offsets, breakpoints, or power series generators. Software solutions include look-up tables, power series expansions, and piece-wise approximations. For tables and power series coefficients, the reader is referred to the ASTM Publication 470A.

Hardware correction for nonlinearity can be as simple as an offset term. This is shown in Figure 5. The thermocouple shown in the figure has an increasing slope ( $\alpha$ ) with

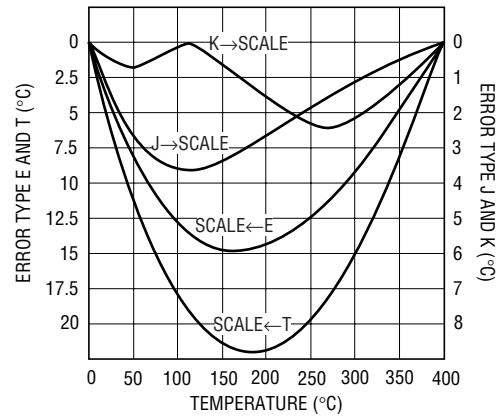

Figure 4. Thermocouple Nonlinearity, 0°C to 400°C

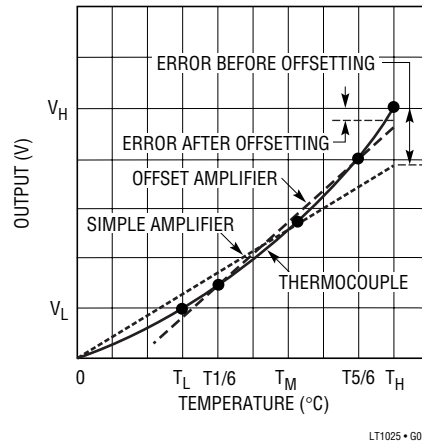

Figure 5. Offset Curve Fitting

temperature. The temperature range of interest is between  $T_L$  and  $T_H$ , with a calibration point at  $T_M$ . If a simple amplifier is used and calibrated at  $T_M$ , the output will be very high at  $T_L$  and very low at  $T_H$ . Adding the proper offset term and calibrating at  $T_1/6$  or  $T_5/6$  can significantly reduce errors. The technique is as follows:

1. Calculate amplifier gain:

$$G = (SF) (T_H - T_L) / (V_H - V_L)$$

SF = Output scale factor, e.g., 10mV/°C  
 $V_H$  = Thermocouple output at  $T_H$   
 $V_L$  = Thermocouple output at  $T_L$

2. Use precision resistors to set gain or calibrate gain by introducing a precision “delta” input voltage and trimming for proper “delta” output.

## APPLICATIONS INFORMATION

3. Calibrate output by adding in a true offset term which does not affect gain (by summing, etc.). Calibration may be done at any temperature either by immersing the thermocouple in a calibrated bath or by substituting a precision input voltage. The method which tends to minimize worst-case error over the whole  $T_L$  to  $T_H$  range

is to calibrate at 1/6 or 5/6 of span. This may be modified if best accuracy is desired at one particular point.

Breakpoint correction for nonlinearity is more complicated than a simple offset, but a single breakpoint combined with offset will reduce errors typically by 4:1 over a simple offset technique.

## TYPICAL APPLICATIONS

**Eliminating Amplifier Feedback Resistors  
(Output Goes Negative with Increasing Temperature)**

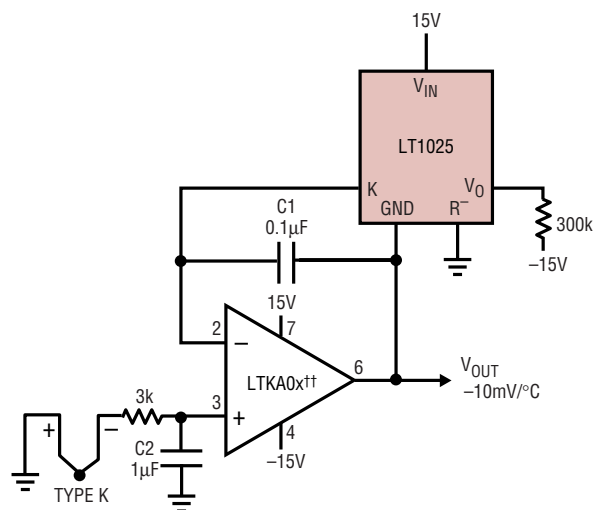

†† OR EQUIVALENT. SEE "AMPLIFIER CONSIDERATIONS"

**Type K Thermometer with Grounded Thermocouple**

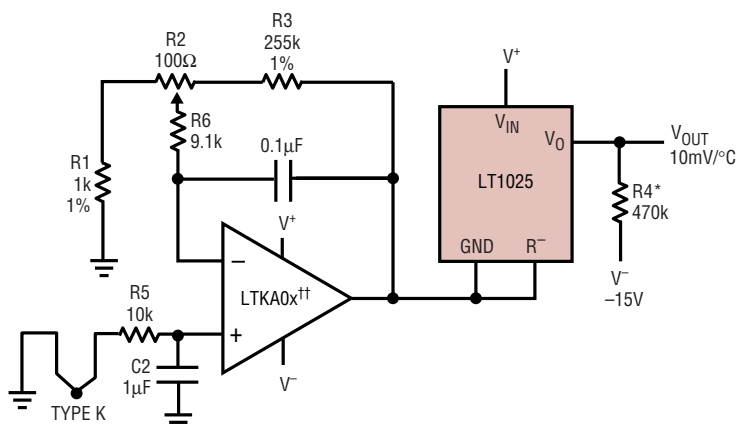

\* $R_4 \leq \frac{V^-}{30\mu A}$  IF OUTPUT MUST SINK CURRENT,  $R_4$  MUST BE DECREASED APPROPRIATELY.  $R_4$  IS NOT REQUIRED (OPEN) FOR LT1025 TEMPERATURES  $\geq 0^\circ C$  WHEN SOURCING CURRENT ONLY  
†† OR EQUIVALENT. SEE "AMPLIFIER CONSIDERATIONS"

TYPICAL APPLICATIONS

Differential Thermocouple Amplifier

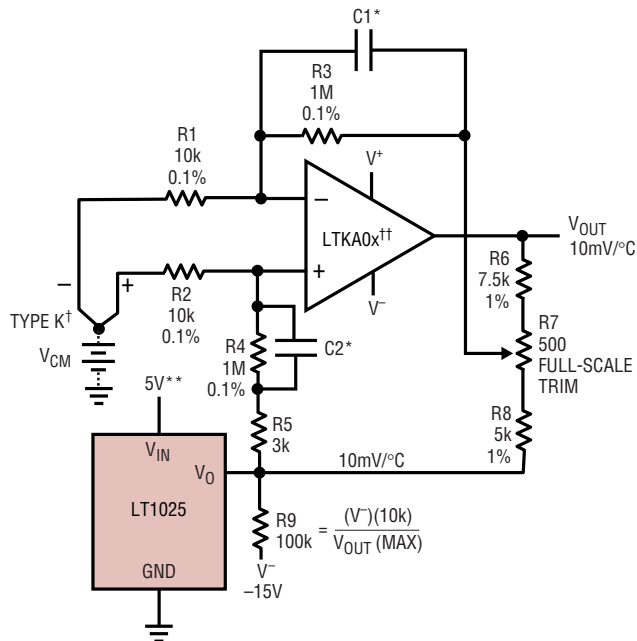

\*C1 AND C2 FILTER RIPPLE AND NOISE, BUT WILL LIMIT AC COMMON-MODE REJECTION IF NOT MATCHED. SUGGESTED VALUES ARE 0.001μF TO 0.1μF  
 \*\*USE LOWEST POSSIBLE SUPPLY VOLTAGE TO MINIMIZE INTERNAL TEMPERATURE RISE  
 † FOR BEST ACCURACY, THERMOCOUPLE RESISTANCE SHOULD BE LESS THAN 100Ω  
 †† OR EQUIVALENT. SEE "AMPLIFIER CONSIDERATIONS"

Utilizing Negative LT1025 Drive to Accommodate Grounded Thermocouple\*

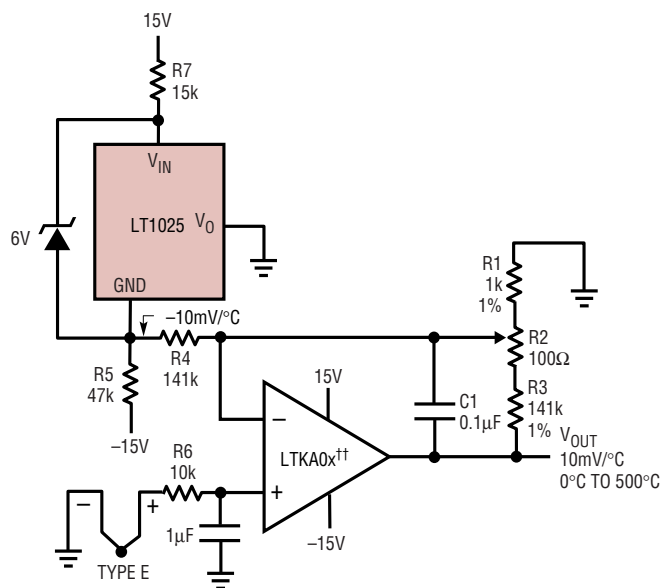

\*SEE "REVERSING THE POLARITY OF THE 10mV/°C OUTPUT"  
 †† OR EQUIVALENT. SEE "AMPLIFIER CONSIDERATIONS"



# TYPICAL APPLICATIONS

## Type S Thermocouple Amplifier with Ultralow Offset and Drift †

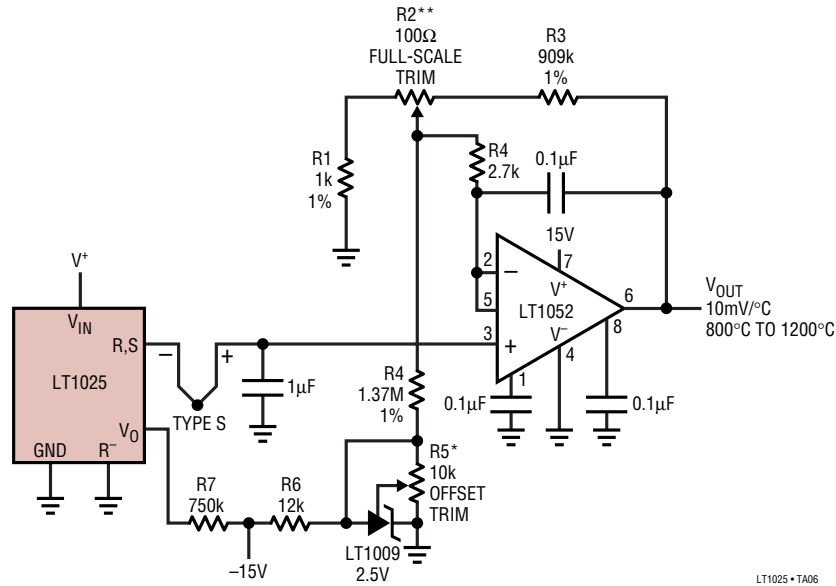

- \* TRIM R5 FOR  $V_{OUT} = 1.669V$  AT  $V_{IN} = 0.000mV$  (+INPUT OF AMPLIFIER GROUNDED)
- \*\* TRIM R2 FOR  $V_{OUT} = 9.998V$  AT  $T = 1000^{\circ}C$ , OR FOR  $V_{IN}$  AT +INPUT OF AMPLIFIER =  $9.585mV$
- † THIS AMPLIFIER HAS A DELIBERATE OFFSET TO ALLOW OUTPUT SLOPE ( $10mV/^{\circ}C$ ) TO BE SET INDEPENDENTLY FROM AN ARBITRARY HIGH TEMPERATURE CENTER POINT ( $1000^{\circ}C$ ). THIS IS REQUIRED BECAUSE THE SLOPE OF TYPE "S" THERMOCOUPLES VARIES RAPIDLY WITH TEMPERATURE, INCREASING FROM  $6\mu V/^{\circ}C$  AT  $25^{\circ}C$  TO  $11\mu V/^{\circ}C$  AT  $1000^{\circ}C$ . NONLINEARITY LIMITS ACCURACY TO  $\approx 3^{\circ}C$  OVER THE  $800^{\circ}C$  TO  $1200^{\circ}C$  RANGE EVEN WITH OFFSET CORRECTION

LT1025 • TA06

**PACKAGE DESCRIPTION**

**J8 Package**  
**8-Lead CERDIP (Narrow 0.300, Hermetic)**  
 (LTC DWG # 05-08-1110)

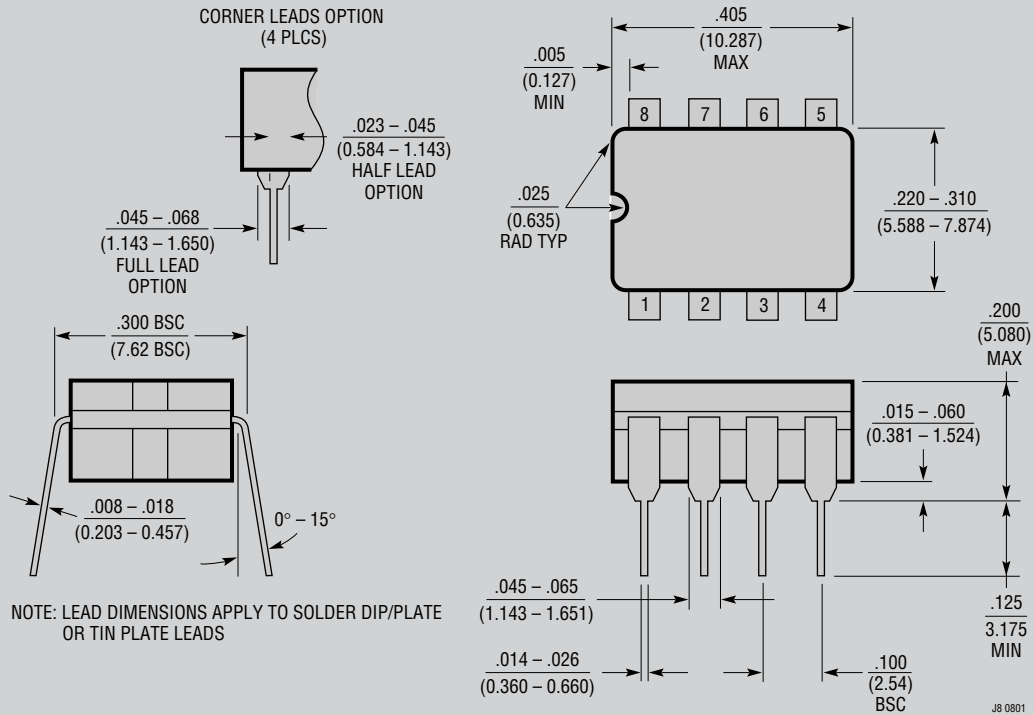

**OBSOLETE PACKAGE**

# PACKAGE DESCRIPTION

## N8 Package 8-Lead PDIP (Narrow 0.300) (LTC DWG # 05-08-1510)

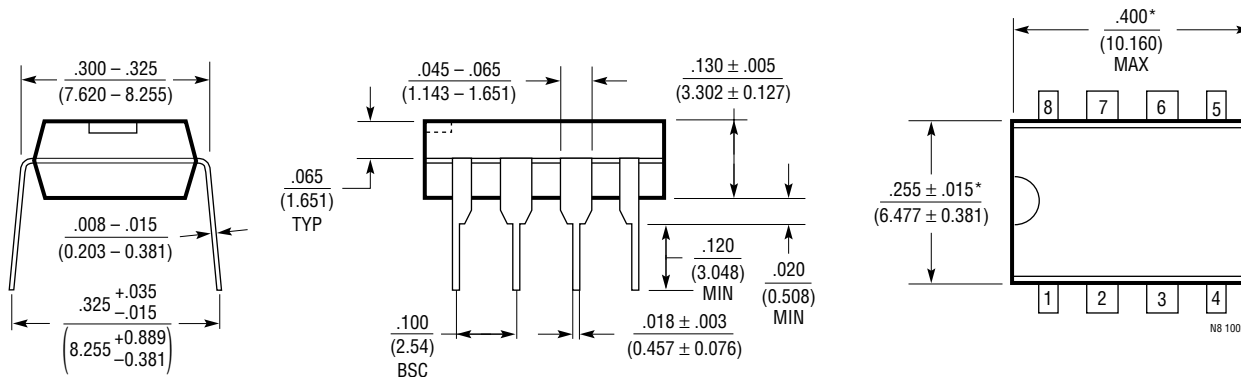

NOTE:  
1. DIMENSIONS ARE  $\frac{\text{INCHES}}{\text{MILLIMETERS}}$   
\*THESE DIMENSIONS DO NOT INCLUDE MOLD FLASH OR PROTRUSIONS.  
MOLD FLASH OR PROTRUSIONS SHALL NOT EXCEED .010 INCH (0.254mm)

## S8 Package 8-Lead Plastic Small Outline (Narrow .150 Inch) (Reference LTC DWG # 05-08-1610)

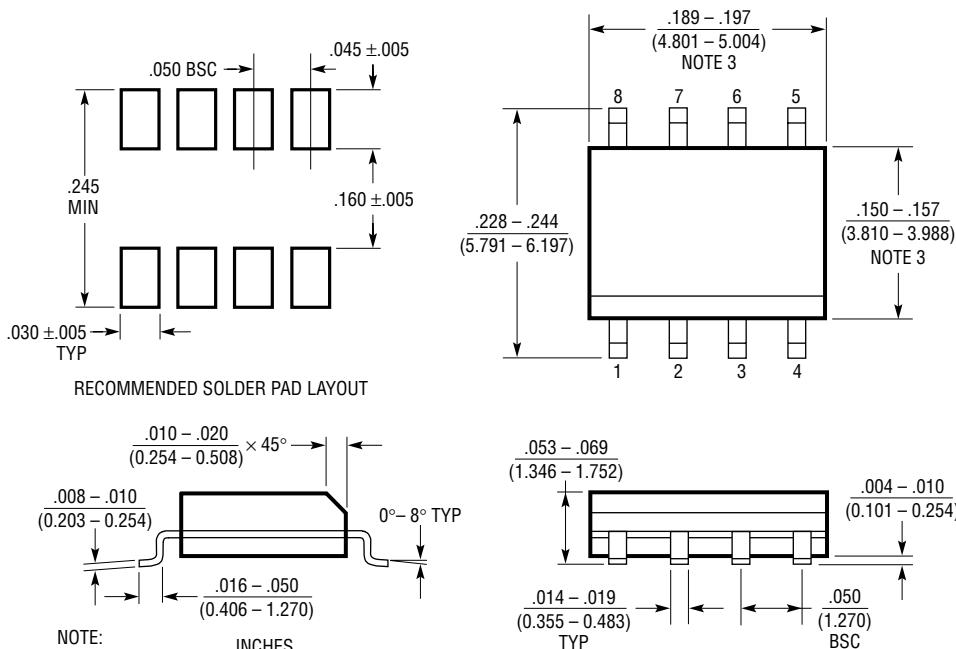

NOTE:  
1. DIMENSIONS IN  $\frac{\text{INCHES}}{\text{MILLIMETERS}}$   
2. DRAWING NOT TO SCALE  
3. THESE DIMENSIONS DO NOT INCLUDE MOLD FLASH OR PROTRUSIONS.  
MOLD FLASH OR PROTRUSIONS SHALL NOT EXCEED .006" (0.15mm)

S08 0303

## TYPICAL APPLICATION

Grounded Thermocouple Amplifier with Positive Output

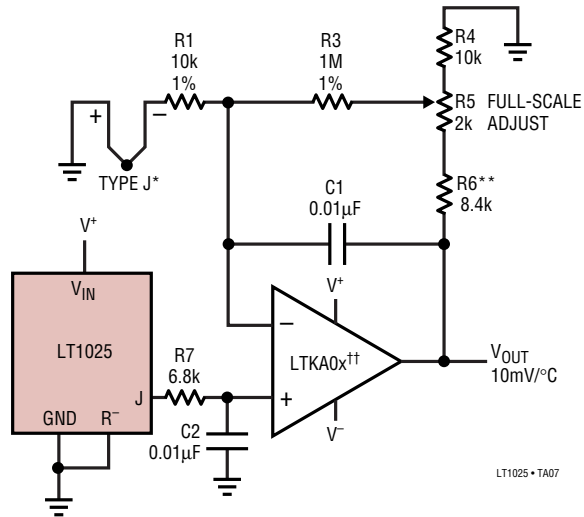

\* FOR BEST ACCURACY, THERMOCOUPLE RESISTANCE SHOULD BE LESS THAN  $50\Omega$   
 \*\* SELECTED FOR  $0^{\circ}\text{C}$  TO  $200^{\circ}\text{C}$  RANGE  
 †† OR EQUIVALENT. SEE "AMPLIFIER CONSIDERATIONS"

## RELATED PARTS

PART NUMBER	DESCRIPTION	COMMENTS
LT1012	Picoamp Input Current Op Amp	$120\mu\text{V}$ Max $V_{OS}$ , $280\text{pA}$ Max $I_{OS}$
LTC1050	Zero Drift Amplifier	$5\mu\text{V}$ Max $V_{OS}$ , $A_{VOL}$ $1\text{V}/\mu\text{V}$ Max
LTC2050	SOT-23 Zero Drift Amplifier	$3\mu\text{V}$ Max $V_{OS}$