

Mounting Guidelines for the SUPER-247

by Andrew Sawle and Arthur Woodworth

Introduction

Born from the need to accommodate ever increasing amounts of silicon in smaller, space saving packages, the SUPER-247 now allows the same die sizes that can be put in a much larger TO-264. The SUPER-247 has the same outer dimensions as the industry standard TO-247 but can dissipate more power than the TO-247 whilst occupying less space than the TO-264. This package also allows the use of efficient and reliable clip mounting methods to heatsinks. This allows designers to reduce both the size and the cost of their systems.

This Application Note will examine the subjects involved with clip mounting the SUPER-247 to heatsinks.

Topics Covered:

A breakdown of system thermal resistance.

The minimum force for a good thermal contact and the maximum force allowable before device parameter degradation.

Wet and dry contact conditions and the effect on thermal resistance.

The effect on thermal resistance of using an electrical isolator between the device and the heatsink.

Typical clip types, how they work and the forces that they impart. Conclusion.

1. A Breakdown of System Thermal Resistance

The thermal resistance ($R_{th(junction-ambient)}$) of a system (system = package through to heatsink) is made up from a number of component parts as shown in Figure 1.1 below.

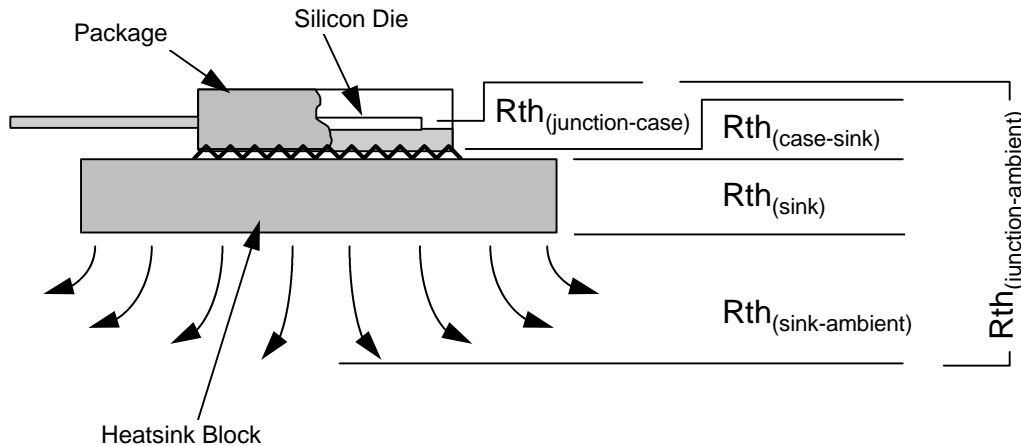

Figure 1.1 - Build-up of Thermal Resistance in a System

The designer of a system has varying amounts of influence over the component parts of the overall thermal resistance of his design:

- $R_{th(junction-case)}$ - this has been determined during the design and manufacture of the product. The system designer has no direct influence.
- $R_{th(case-sink)}$ (or **Contact Thermal Resistance**) - determined by the size and quality of the contact areas between the package and the sink, the use of intermediate materials and the contact pressure. Hence, the system designer can have a large influence over this parameter.
- $R_{th(sink)}$ and $R_{th(sink-ambient)}$ - determined by heatsink design, *i.e. material and shape*. System designer will choose optimum sink matching both performance and cost requirements.

Thermal resistances for packages and heatsinks can be determined from datasheets and although the contact thermal resistances can also be taken from manufacturer's data, this figure is generally 'TYPICAL' and for a single set of specified conditions. Hence, it is possible for a designer to gain better or worse contact thermal resistances depending on parameters that he prescribes. The following sections include some information to help the designer in improving rather than worsening contact thermal resistances in their systems.

2. Minimum and Maximum Contact Forces

As previously mentioned, there are a number of factors that affect the contact thermal resistance, one of the factors being the contact force with which the package is pushed against the heatsink.

Why and How Does Contact Force Affect Thermal Resistance?

Package cases and heatsink surfaces can never be perfectly flat. Hence contact between the two will only occur at several points allowing an air gap between the surfaces (as illustrated in Figure 1.2). Since air is a very good thermal insulator this means that the contact thermal resistance is much greater than it would be if the two surfaces were in perfect contact (no air gap). However, as the contact force (pushing the two surfaces together) increases then so will the number of points at which the two surfaces contact one another and the air-gap will be reduced, in turn reducing the contact thermal resistance.

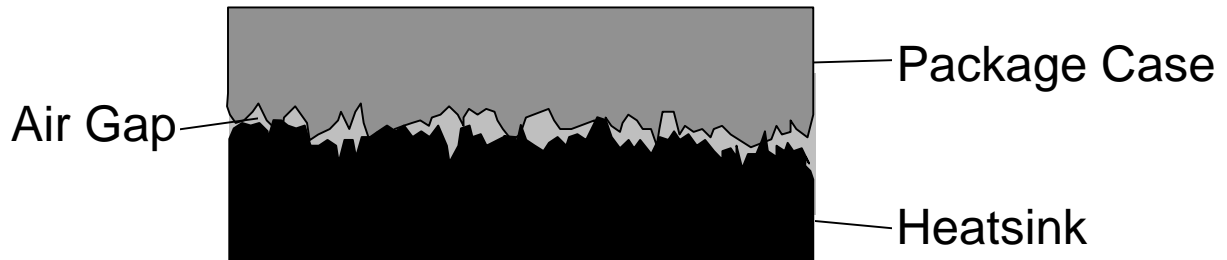

Figure 1.2 - Diagram Showing the Effect (Under High Magnification) When Two Non-Perfect Surfaces Meet.

What is the Minimum Force that Should be Applied to Gain Good Thermal Contact?

As the contact force is increased, the contact thermal resistance decreases. However, this does NOT follow a linear relationship and shows diminishing returns in thermal resistance reduction for increases in the contact force (as shown in Figure 1.3). A rapid initial fall-off in contact thermal resistance is replaced by a more gradual reduction with increased contact force. The minimum contact force should therefore be no lower than the point at which these rapid reductions in thermal resistance end - this occurs at approximately 20N.

Maximum Contact Force

The minimum contact force of 20N mentioned above is purely that, the MINIMUM force. Any force applied above that figure will still show gains in reduced contact thermal resistance until the maximum force that the package can withstand before the device characteristics are altered or the package is destroyed. This maximum limit figure has been measured to be 200N TYP. However, these gains are not free, for in general terms a greater contact force means a larger, more expensive clamping system. A contact force should therefore be chosen that optimises both the thermal and the cost requirements of the system.

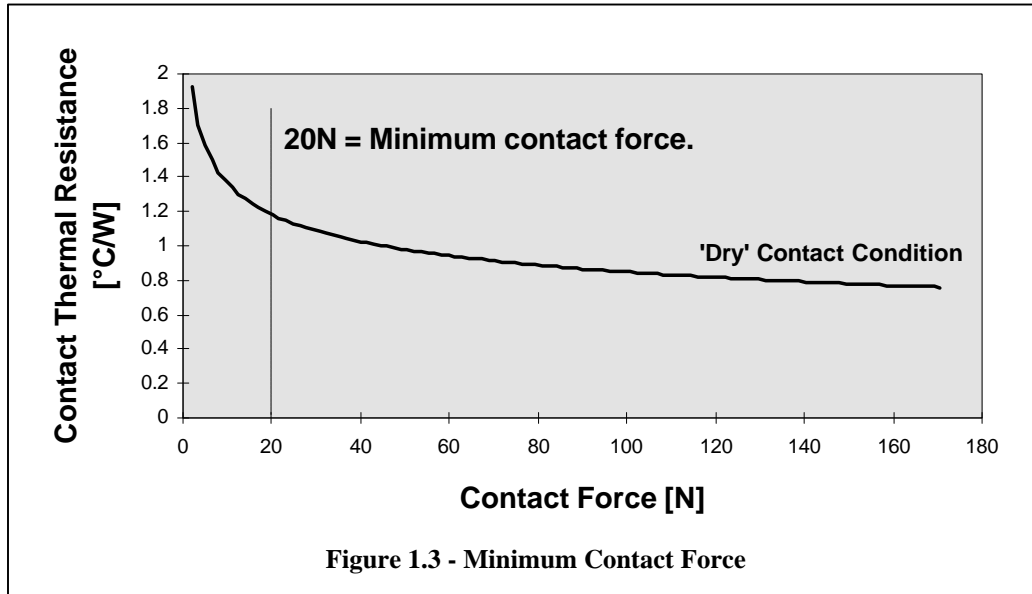

Figure 1.3 - Minimum Contact Force

3. Contact Conditions

As mentioned previously, the contact conditions between the package and the heatsink will affect the contact thermal resistance. Contact conditions encompass a number of areas including: surface roughness, surface cleanliness, paint finishes and intermediate materials. The surface roughness of the heatsinking material should be no greater than 0.02mm over the area where the device is to be mounted. Surface cleanliness during assembly of package and heatsink is imperative, even if a thermal grease or other material is subsequently added. Unclean surfaces can be held apart by dirt or grease thus increasing the thermal resistance. However, normal paint finishes (up to 50 μm thick) have been shown to have little effect on thermal resistance, this therefore leaves intermediate materials as an area for discussion.

Intermediate Materials

Contact between two non-perfect surfaces will result in an air gap between them. The most common method of overcoming this is to use a thermally conductive heatsinking compound to fill the gaps between the surfaces and hence lower the contact thermal resistance. This compound also has the advantage that it prevents moisture from penetrating between the surfaces.

A number of different companies offer heatsinking compound, these usually consist of silicon grease loaded with some electrically insulating, good thermally conducting material such as alumina. Thinly applied, these compounds are advantageous as they fill the air gaps and do not further increase the distances between the surfaces. Thickly applied they can hold the two surfaces apart and increase the contact thermal resistance. The following graph displayed in Figure 1.4 shows the contact thermal resistance for 'dry' conditions (no compound) and the thermal resistance using compound, both are plotted against contact force.

The metal heatspreader on the back of the SUPER-247 package is non-electrically isolated from the pinouts of the device within, *i.e. in the case of a MOSFET the heatspreader is the drain contact, for an IGBT the collector*. Hence in cases where devices are not electrically paralleled but share the same heatsink, it is necessary to insert an electrically isolating material between the package and the heatsink block. The isolator usually takes the form of a pad and many companies offer a range of pad material types and sizes dependant on requirements.

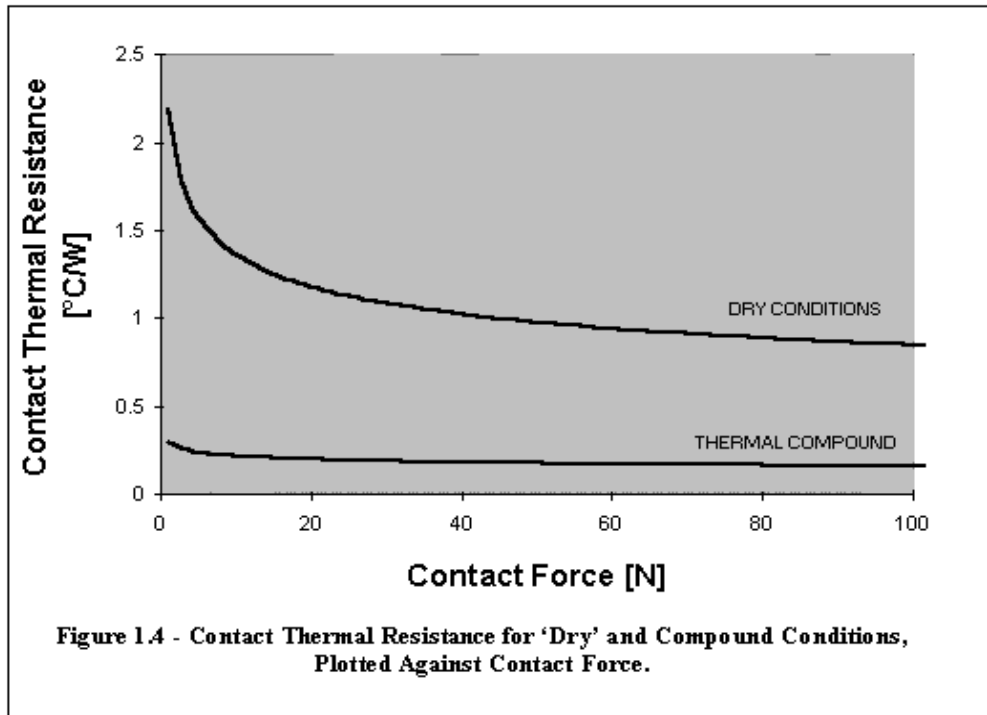

At the minimum stated contact force of 20 N the following contact resistances can be achieved:

Contact Conditions	$R_{th(c-s)}$ @ 20N Contact Force
'Dry' (no compound)	1.2°C/W
Thermal Compound	0.2°C/W

The pad obviously has a direct and detrimental effect on the contact resistance as insertion adds an extra resistance into the build-up. Again, the contact thermal resistance is dependant on contact pressure. The following graph, shown in Figure 1.5, illustrates the higher thermal resistance when using an isolator pad, adding a new line to the thermal resistance curve. The isolator used to plot the line was a typical silicone loaded pad. Therefore, it should be noted that when electrically isolating a device from a heatsink the thermal resistance of the system will increase.

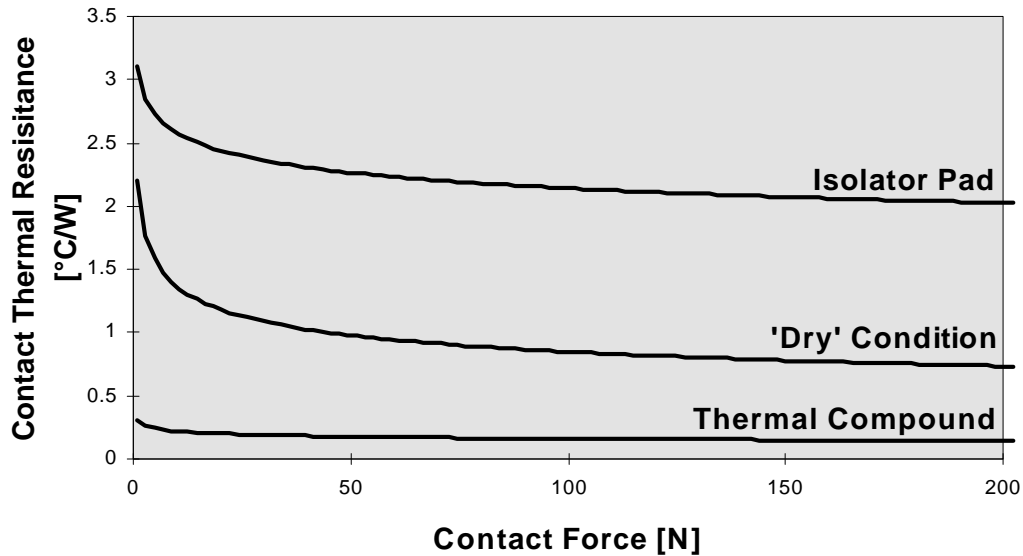

Figure 1.5 - Contact Thermal Resistance Plotted Against Contact Force

4. Typical Clips and What They Do

Why Clips?

The use of clips for providing the contact pressure is quickly becoming popular. Clip mounting provides a number of advantages over the more traditional screw mounting techniques:

- **Clips provide a more uniform pressure** over the entirety of the mating surfaces. Although screw mounting can provide a higher pressure, the force is centred at one end of the package and there is often a loss of coplanarity between package and heatsink.
- **Clips are faster to apply** than aligning and tightening screws.
- **Clips regulate the force applied** and ensure that the same force is applied to each package/heatsink pair. Hence there is no danger of over-tightening (deforming the package and/or heatsink) or under-tightening (increasing the contact thermal resistance).

Clip Types

There are a number of different clip types available on the market that can be used dependant on the application. Following are some examples of clips and the way in which they are typically used. The ideas shown by no mean encompass all the solutions available and do not prescribe the only ways in which the clips can be used.

Saddle Clips

An example of a SUPER-247 mounted to a heatsink using a saddle clip is shown in Figure 1.6.

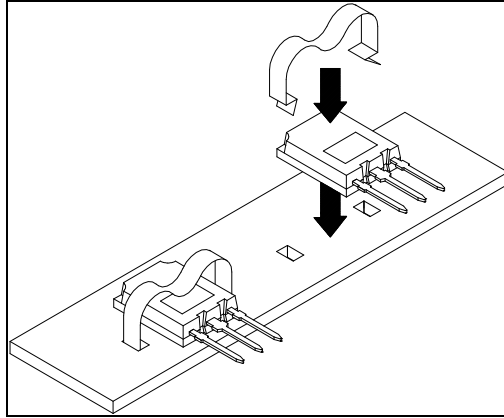

Figure 1.6 - SUPER-247 Mounted to Heatsink Using Saddle Clip

When using saddle clip type solutions, the heatsink materials are thin in cross-section, typically less than 5mm in thickness. The clips push into holes cut into heatsink material and lock against the back face of the heatsink. These clips produce contact forces in the range 20-60N.

'U' Clips

An example of a 'U' Clip assembly is shown in Figure 1.7.

This clip type clamps the device and the heatsink material together. Variations on this clip type allow devices to be clamped to the front and back of the heatsink block using the same clip. 'U' clips typically impart forces in the 20N-40N range. This force is partly dependent of the thickness of the heatsink material, *i.e. thicker the material, the greater the force.*

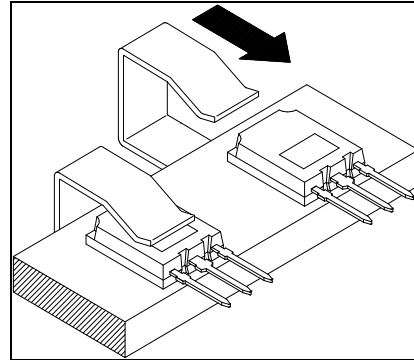

Figure 1.7 - 'U' Clip Assembly

Extrusion Mounted Clips

There are a number of proprietary clip solutions offered where the clip is anchored in a feature in the extruded heatsink. Figure 1.8 shows one solution type where the clip fits into a shaped slot in the heatsink material.

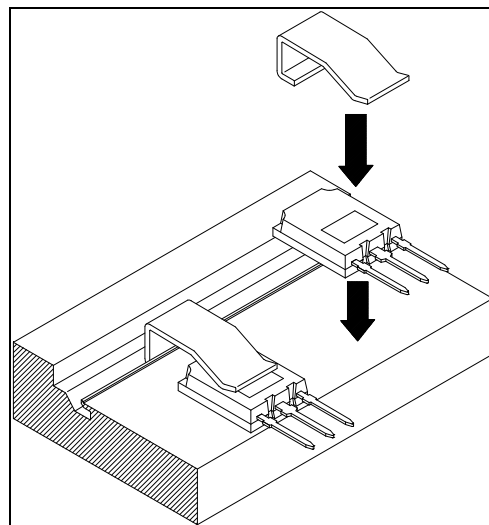

Figure 1.8 - Extrusion Mounted Clip (Slot Anchorage)

This solution can produce contact forces in the range 15 - 25N. However the shaped slot is an expensive addition to the heatsink and this solution type is being replaced in favour of clips mounted between shortened heatsink fins or clip rails (as shown in Figure 1.9 below). The extruded heatsinks are less costly and the forces that can be applied are higher, typically in the range 25 - 50N

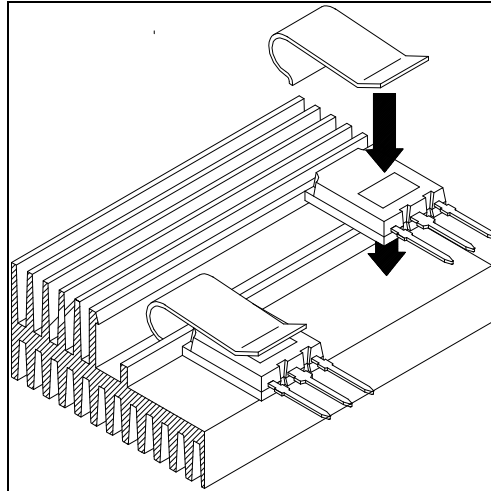

Figure 1.9 - Extrusion Mounted Clip (Rail Anchorage)

Other Solutions

Heatsink manufacturers offer a wide range of heatsink types, usually extrusions or formed metal and at a cost are willing to produce customised solutions. Some manufacturers will supply the heatsink with integrated clip both in extruded and formed metal varieties or a combination of the two. It is also possible to have heatsink solutions supplied with thermal compound or isolator materials already applied in the correct places to aid assembly.

Sources for Clip Solutions

The following are companies who can supply the types of clips/solutions discussed in this Application Note:

Redpoint Thermalloy,
Cheney Manor,
Swindon,
Wiltshire.
SN2 2QN

Aavid Thermal Technologies,
Corporate Headquarters,
One Kool Path,
Laconia,
New Hampshire
USA

Austerlitz Electronic gmbh,
Ludwig Feuerbach -Straße 38,
90961 Nüenburg, Postfach 1048,
GERMANY

Relevance to TO-247 Heatsink Mounting

The clipping/mounting concepts covered in this application note for the SUPER-247 can also be applied to the standard TO-247 package. However, it should be noted that due to the screw mounting capability of the standard TO-247 the package to heatsink contact area is reduced and hence the contact thermal resistance is **INCREASED** from $0.2^{\circ}\text{C}/\text{W}$ (SUPER-247) to $0.24^{\circ}\text{C}/\text{W}$ (TO-247). Therefore, whilst the minimum clamping force of 20N still applies, the contact thermal resistance graph for the SUPER-247 will not.

Conclusion

The SUPER-247 package can now dissipate more power and encapsulate more silicon than the industry standard TO-247, a package with the same footprint. It also allows for faster and less costly clip mounting to heatsinks. However, the way in which the device is mounted to the heatsink will affect the thermal performance of the system (silicon, package and heatsink). The designer can have a direct affect on the contact thermal resistance and the design parameters that he sets can have either a positive or adverse effect on system performance. This Application Note has discussed the need for an adequate force (20N) for good thermal contact and the fact that intermediate materials also affect the thermal resistance. Thinly applied thermal compound will improve the contact thermal resistance whilst electrical isolators are likely to cause deterioration in this parameter.

There are many clip/heatsink solutions available and some have been indicated in this Application Note. The chosen solution will depend on the application in which it is used and should be chosen to optimise both cost and thermal performance characteristics.