

X-10 Compatible Appliance Module

Philip C. Plunkett
pplunkett@cix.co.uk
ABACUS ELECTRICS
10 Barley Mow Passage
Chiswick, London, W4 4PH, U.K.

Document Revision 1.0 - May 1997
Source Code Revision 1.28 - August 1996

Introduction

This document describes in detail the design of an X-10 compatible appliance module that may be constructed as-is or customised by a competent home constructor. All functionality is supplied by a PIC16C54 micro-controller at the heart of the module. Schematic, circuit description, printed circuit board design and full source code are provided.

Disclaimers

The module was designed not for financial gain but for the authors own use. It was designed without the knowledge or co-operation of the X-10 company but used information contained within their TW523 documentation. The author does not intend to profit from the design and will not supply assembled units or parts. Certain aspects of X-10 power-line communication have been protected by patent. No liability will be accepted by the author for any legal action taken by the X-10 company against constructors or vendors who chose to sell modules or programmed PICs based upon this design. In practice it is not possible to save money by making X-10 modules. Mass production, low cost parts, Far East labour costs and keen marketing ensure the X-10 brand product will be significantly cheaper than a home-made product. Home constructors will be interested in customising the module in some way; adding features that are unavailable in a ready-made product.

Construction of the 'clone' appliance module should only be undertaken by an experienced constructor with access to test equipment. In use and during test the circuit is connected directly to the power-line and so danger is involved. The author accepts no liability for the health and safety of the constructor assembling or modifying this design.

Enough of the disclaimers.

General

X-10 has never caught on in the UK. Available only from a handful of mail order suppliers the cost of modules was typically twice that in the USA. In 1996 the technical requirements for RF emission and susceptibility (EMC) became more stringent and passed into European law. Electrical goods had to be labelled with the 'CE' mark to indicate their compatibility with the regulations. X-10 equipment was not so marked and rather than risk fines a number of the suppliers ceased stocking

Having a modest investment in X-10 modules and needing more the choice was to either to import or to design. As the requirement was for something specific and non-standard to design seemed the best (and more interesting) option. The need was for a number of 240 volt hard-wired appliance modules switching loads up to 500 watts. They had to be built into waterproof housings and work reliably outside in all weathers. The actual application was to switch lighting, pumps and fountains in the authors garden.

The cheapness of micro-controllers such as the Microchip PIC mean that they are ideally suited to applications such as the X-10 compatible appliance module. The micro-controller ROM, RAM and speed are more than adequate for the limited requirements of the module. The PIC must control a load switch, detect power-line zero-crossings, detect the 120kHz X-10 carrier, read house and unit address switches and sense a manual on-off push-button. Twelve I/O pins are needed in total; one output and eleven inputs. A PIC16C54 fits the bill perfectly.

Load Switch

To control a mains rated load there are two options; either to use a relay or a triac. A relay is appropriate for very high power loads, very low power loads, isolated loads and where only relatively slow toggling rates are needed. A triac is suitable for switching non-isolated medium power loads and where rapid control (i.e. dimming) may be required. The author wished to switch lighting, pumps and fountains in his garden so a triac was chosen.

The triac is a cheap three-terminal device designed to switch high voltage AC supplies and is used extensively in lamp dimmers and motor speed controllers. The two 'Main Terminals' MT1 and MT2 are wired in series with the load and block current to it. When a small 'trigger' current is allowed to flow between the Gate terminal and MT1 conduction occurs between MT2 and MT1. Once the triac has switched on the load current will continue to flow even if the gate current is removed - providing that the load current exceeds the 'latching' value,. To switch the load off the load current must be reduced below the 'holding current'. Latching and holding currents are specified by the triac manufacturer . As we are considering an AC supply the load current will automatically switch off at the end of the next 50Hz (60Hz) half-cycle.

To sustain load current beyond a single half-cycle of the AC supply then either the triac must be re-triggered each half-cycle or the gate current must be maintained continuously. Pulse triggering has the advantage that lower average current is required from the DC supply. Typically the trigger pulse will occur shortly after the supply zero-crossing in order to minimise the generation of radio frequency interference. At this point the load current will be low and increasing. The duration of the trigger pulse must be long enough for the load current to reach the latching current. This delay will be dependant upon the value (watts) and nature (resistance/inductance) of the load. For simplicity, continuous gate drive was used in this design.

A TIC206D triac was chosen as it requires a low gate current to trigger. A 4 amp device, it will comfortably switch a 500 watt load with a 240 volt AC supply. A 115 volt supply would require a higher current triac to switch similar load power. Higher current triacs usually require a higher gate drive which can not be supplied without modifying this design. High sensitivity triacs such as the TICF225M or BTA10-600CW could perhaps be used but have not been tried.

Power Supply

The PIC16C54 and associated circuitry require a low voltage supply, typically 5 volts. A conventional approach would be to use a small step-down transformer along with a rectifier, smoothing capacitor and regulator. The transformer would also provide safety isolation from the power-line. As the PIC will be driving the gate of the triac load switch it will inevitably be connected directly to the power-line and so the isolation provided by the transformer is irrelevant. As the current required is not great a 'wattless' or capacitor power supply is suitable.

In our design the supply is formed by capacitors C1 and C2 along with diodes D1 and D2. C1 is non-polar and must be of high quality and adequate voltage rating as it carries the full power-line voltage.

On the power-line half-cycle when neutral is negative with respect to live then current flows through C1 and D2 to develop the 5.6 volt 'zener voltage' across D2. D1 will conduct and its forward voltage drop subtracted from the zener voltage will result in approximately 5 volts being developed across C2, the supply reservoir capacitor. On the power-line half-cycle when neutral is positive with respect to live then current flows through C1 and D2 however D2 will forward conduct. D1 will be reverse biased and will prevent discharge of the reservoir capacitor, C2. We thus have a half-wave rectified, smoothed 5 volt supply, the positive terminal of which is connected to the power-line live conductor. The amount of current available is determined by the power-line voltage and the reactance of capacitor C1 at the power-line frequency. With a 240 volt AC supply and a 0.47uF capacitor approximately 14mA is available. For a 115 volt power-line voltage C1 should be 1.0uF.

To reduce inrush current when power is connected to the module a low value resistor R1 is placed in series with C1. If the module is disconnected from the power-line capacitors C1 and C3 could remain charged and give a shock. To prevent this a high value resistor R2 provides a discharge path. A 275 volt varistor VDR1 is connected directly across the power-line to protect the module from any transient voltage spikes. For a 115 volt power-line voltage a 130 volt varistor should be used.

120kHz Tuned Amplifier/Signal Conditioner

The X-10 signal consists of a pattern of 1msec bursts of a 120kHz carrier superimposed on the power-line and synchronised to the power-line frequency (50Hz/60Hz) zero-crossings. Transported over the house wiring the carrier may be only tens or hundreds of millivolts at the receiving module. This carrier must be amplified, limited, and the envelope converted to a logic level signal that the PIC16C54 can detect. The amplification must be highly selective in order to reject interfering signals also present on the power-line. The power-line frequency, hugely greater in magnitude than the carrier signal, can easily be rejected as the frequency difference is so great. Power-line harmonics from lamp dimmers and other carriers from baby monitors are not so easily rejected.

A very economical way of obtaining a lot of amplification is to use a 4069UB. This CMOS logic chip nominally contains six unbuffered inverters. By connecting negative feedback from the output to the input of a gate and biasing the output to sit roughly at half the supply rail it becomes a linear amplifier (we are not talking hi-fi here). With six such gates there is a lot of gain available.

The input stage of the amplifier comprises a transformer tuned to the 120kHz carrier frequency. The primary of the transformer, in series with capacitor C3, is directly across the power-line. Capacitor C3 presents a low impedance at the carrier frequency but a high impedance at the power-line frequency. The carrier signal is passed but excessive 50Hz (60Hz) currents are blocked. Back-to-back zener diodes D3 and D4 provide some overload protection for the 4069UB input and C5, R3 and R4 provide a little extra high-pass filtering.

The first two stages of amplification provided by the 4069UB gates are tuned. Small axial inductors with parallel capacitors peak the response at 120kHz. The next two stages are untuned but provide sufficient amplification to produce an output voltage swing from rail-to-rail at the carrier frequency. Diode D5 along with R9 and C14 form a demodulator, the output of which represents the envelope of the 120kHz carrier. The fifth 4069UB gate buffers the demodulator (envelope detector) output and feeds it to an input pin on the PIC micro-controller. Typically a carrier signal level of 20mV produces reliable logic level transitions at the PIC input.

PIC Micro-controller

The heart (or more accurately the brains) of the appliance module is the PIC micro-controller. At a hardware level its function is to check for the presence of the 120kHz carrier, check for key-presses on the manual on-off push-button, read the house/unit address switch, detect power-line zero-crossings, and drive the triac load switch. Almost any member of the PIC family could have been selected. The PIC16C54 was chosen simply because it was cheap, available, and had sufficient input/output pins. Although precision timing was not needed a crystal was used for the processor clock. Despite reservations the modules worked reliably at sub-zero temperatures.

To detect the 120kHz carrier it is only necessary to read the high/low state of the RA2 input pin as the 4069UB amplifier has done the hard work and delivers a logic level signal. Reading the status of the manual on-off switch is similarly trivial. R10 provides a pull-up voltage to input RA3; pressing the momentary push-button SW1 takes the input low. Toggling the load on and off using a single momentary switch is achieved in software.

An X-10 house address can have sixteen possible values, designated A to P. The unit address can also have sixteen values, designated 1 to 16. Each of these two values can be represented by a four-bit binary number, 0000b to 1111b (0 to 15). Ideally two four-bit binary coded switches would be used, one labelled A to P and the other 1 to 16. Unfortunately such switches are not available, though miniature rotary binary-coded switches labelled 0 to F (hexadecimal) can be found. As the clone appliance module was not designed to be placed on the market the convenience of these switches was deemed unnecessary and a simple 8-pole single-throw DIP switch was used. Multiplexing was not used and so eight input pins (RB0 to RB7) are needed to read these switches.

To detect zero-crossings the power line is connected to the RA1 input of the PIC via a current limiting resistor. All PIC input/output pins are fitted with static protection circuitry and this clamps any overvoltage to within 0.6 volts of the supply rails. Resistor R11 limits the current into the RA1 input pin to approximately 70uA.

Construction

If the X-10 compatible appliance module is assembled and connected to a load and the power-line it *may* work first time. However, range and reliability will be improved if the tuning of the 120kHz amplifier is optimised. To set up the appliance module it is advisable to have available a voltmeter, signal generator, lab power supply, oscilloscope and frequency meter.

As the module attaches directly to the power-line connecting test equipment can be hazardous. For this reason as much of the circuitry as possible should be tested before connecting to the power-line. When needed a low voltage lab supply can be used to provide the power. Unless very confident it is a good idea to leave out the PIC16C54 until the rest of the circuitry has been verified.

Tuned transformer TX1 is designed to resonate at 125kHz when used with the specified 33nF capacitor (C4). The X-10 carrier frequency is nominally 120kHz. Connect the signal generator, accurately set to 120kHz, to the power input terminals. With an oscilloscope monitoring the transformer secondary tune the core for maximum output.

The tuned amplifier can also be set up without connecting the module to the power-line. Set the lab power supply to 5volts and connect it across reservoir capacitor C2. The output pins of the 4069UB gates used in the amplifier should sit at approximately 2.5 volts. The signal generator, connected to the power input terminals, should be swept in frequency around 120kHz. With the values shown for C7 to C10 the output at U1E should peak at 120kHz falling off steeply either side. Component tolerances may produce a resonant peak offset from 120kHz and so it may be necessary to select C7 and C9.

Once the tuned amplifier is set the lab supply can be disconnected and the module plugged into the power-line. Check with a voltmeter that 5 volts is developed across C2. If all is well then inserting the PIC16C54 should produce a functional module.

Source Code

The source code is commented and so will not be explained in detail here. The source will assemble correctly using version 1.30 of the Microchip MPASM assembler. A single file has been used without any processor-specific include files. Macros have been used where they improve clarity.

The PIC16C54 does not support hardware interrupts and so once the inputs, outputs, and variables have been initialised the program flow is arranged in a loop. The manual push-button switch and zero-cross detector are regularly polled. Sampling the 120kHz carrier after each power-line zero-crossing the X-10 start sequence "1110" is tested for. If found then subsequent cycles are sampled to extract the X-10 data.

The X-10 raw data was read from an MC563 mini-controller, an MT522 mini-timer, and an SH624/ND561 RF remote/security console. (These modules are 240 volt versions produced for the UK market). It was found that the data stream produced by the ND561 security console differed slightly in that an extra 'blank' cycle was produced in the gap between the house/unit and house/function data sequence. The software was written to overlook this difference by re-synchronising with the data half way through.

The X-10 data stream is highly redundant, all addresses and commands being duplicated. This could be used for error checking however reliable communication was found to be possible without this software overhead. The entire sequence for a single command is shown below. The first house and unit addresses are captured, then, after re-synchronising with the start code following the gap, the first function code is read.

```
start house unit start house unit gap start house function start house function
code  addr  addr code addr addr  code addr  code  code addr
1110  8bit  10bit 1110 8bit 10bit 1110 8bit 10bit 1110 8bit 10bit
```

The house address is transmitted as an eight-bit sequence. Each pair of transmitted bits corresponds to one bit of the actual house code. A '01' sequence transmitted corresponds to a '0' and a '10' sequence corresponds to a '1'. For example, house code C is actually '0010' but would be transmitted as '01011001'. As there is no actual need to convert the 8-bit sequence to the 4-bit code the 8-bit sequence is stored as-is.

The unit address and function codes are transmitted as 10-bit sequences. However the last two bits are always '01' for a unit address code and always '10' for a function code. Being invariant they can be ignored so only the first eight bits of the sequence are stored.

Having captured the house address, unit address and function code from the data stream the transmitted address is compared to the setting of the house/unit address switches. If they match then the transmitted function can then be acted upon.

Look-up tables are used to convert the bit pattern read from the address switches to the bit pattern corresponding to the transmitted data sequence. When designing the printed circuit board artwork it was found that an easier lay-out could be achieved by 'scrambling' the order of the unit address switch connections. Un-scrambling is achieved in the unit address look-up table.

In this implementation only the 'on' and 'off' function codes are acted upon. The 'All Units Off' function is ignored although to add it in should be trivial.

For manual load switching a single push-button was used. 'Push-on' 'push-off' functionality is achieved in software by maintaining the current on-off status. While waiting for the X-10 start sequence to be transmitted the push-button is polled. If pressed then after a delay for de-bouncing the push-button is checked again. If still pressed then the load status is toggled. An additional delay prevents the load from being switched on and off rapidly if the push-button is held closed.

Improvements and further Ideas

It seems to be the nature of engineering that it is always possible to improve upon a design. Looking back a year this project is no exception. In commercial designs development time spent reducing parts count and parts cost is usually time well spent. For low quantity 'home' projects design effort usually stops once the circuitry works reliably.

The present design requires two X2 quality capacitors, one in the power supply and one feeding the tuned transformer. It should be feasible to combine these two circuits so that only one of these bulky expensive capacitors is required. A possible problem with this idea is that the primary of the tuned transformer will pass higher current at the power-line frequency. Unfortunately no data was available for the tuned transformer to know if this would be acceptable.

The 120kHz tuned amplifier would be much simpler to trim if adjustable inductors were used for L1 and L2.

If the author were to redesign the printed circuit board layout then PCB mounted clips for a fuse would probably be incorporated. At the same time the 'earth' connections on the power in and power out terminal block would be removed. If a safety earth connection is required by the load then it is better not to take it via circuit board traces, however thick.

One point of building an X-10 module is so that it can be modified to include some feature that X-10 Inc. did not think of. A few years ago authors of certain articles in hobbyist magazines used to say "applications are limited only by the imagination of the reader". No applications would then be given. This used to irritate this author no end leading him to suspect that the writer might have one of those limited imaginations alluded to. So, here are ten suggestions for X-10 type projects that can build on the circuitry and code of this clone appliance module:

1 Phase Control

An obvious enhancement would be to add phase control for dimming lamp loads. This can be achieved with the present design purely by modifying the software. Variable lamp brightness in triac controlled dimmers is achieved by switching the lamp on every half cycle at a particular point in time in that half cycle. If the lamp is switched on almost immediately after the zero-crossing point then the lamp brightness will be at maximum. The longer the delay into the half cycle before the load is switched on the less power that is delivered to the load; i.e. the lamp is dimmer.

2 Burst Fire Control

Another technique of controlling power to the load is known as burst fire. This method switches the load on and off for entire power-line half-cycles. For example, switching the load on for two half-cycles then off for one would result in 2/3 of maximum power to the load. This method is unsuitable

for lamp dimming as is results in unacceptable flicker. It is, however, suitable for heating applications where time-constants are long compared to the power-line frequency.

3 Local Intelligence #1

X-10 modules are commonly controlled by some central intelligence. This may be a PC running an environmental control program hooked into the power-line via a TW523 interface. In the authors case the central 'intelligence' is slumped in an armchair clutching a remote control handset. Remote control rather than home automation. As a micro-controller is built into the appliance module it could be used to think for itself. Using a digital temperature sensor such as the DS1621 the PIC16C54 can measure temperature. Using the burst fire load control above we have the makings of a temperature control system for a plant propagator, greenhouse etc. By using a TW523 to transmit X-10 'extended-data' commands we could even remotely set the target temperature.

4 Local Intelligence #2

Day/night detection can easily be achieved using a photo-sensor. An ORP-12 light dependant resistor with a 47kohm pull-up resistor works well (in UK daylight). By slowly sampling the ambient light and looking for an unbroken sequence it is possible to ignore momentary effects such as car headlights at night or clouds passing during the day. Knowing if it is day or night would allow the module to make decisions. For example, a module controlling a flood lamp could ignore 'on' commands during daylight or automatically switch itself off at dawn.

5 Local Intelligence #3

By counting power-line cycles quite precise timing is possible. A module could be switched on by a power-line command but switch itself off automatically a fixed time later. This may be appropriate for a slave floodlight tied in with a PIR intruder alarm. In the UK certain local authorities only permit burglar alarms to sound for 20 minutes. Acting as an alarm sounder the module could switch itself off after the permitted time. For accurate timing the PIC processor should determine if it is in a 50Hz or 60Hz country. During initialisation, using the internal timer, it could measure the time between two power-line zero crossings. In practice it is probably adequate to hardcode either 100 or 120 zero crossings per second.

6 Cat Scarer

With the cost of vet bills soaring cat fights are best avoided. Clear the neighbours cats out your garden before letting your prize pet out for his exercise. A harmless ultrasonic 'shriek' will usually see off the unwanted visitors. An ultrasonic transducer of the sort used in intruder detectors can be driven with tens of volts peak-to-peak with the circuit shown. Piezo-horn tweeters have also been used successfully driven at around 25kHz. The tuned circuit is pulsed at resonance, usually in bursts as this seems more effective than a continuous tone.

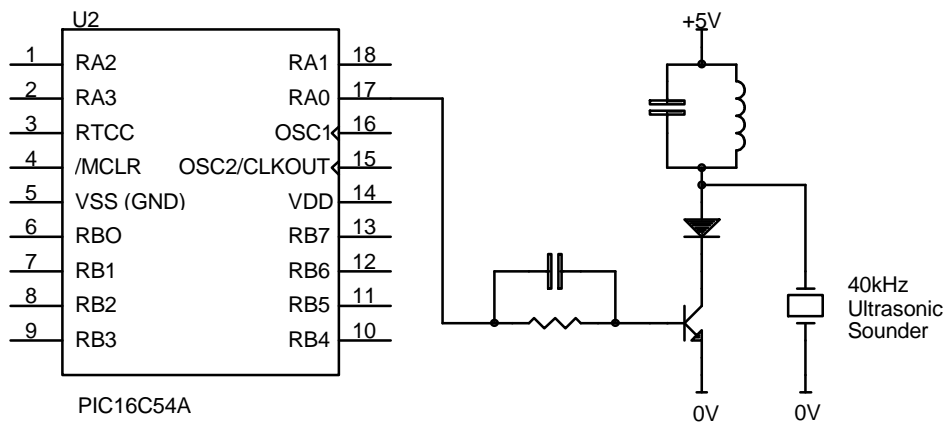

For this design a transformer power supply should be used as the ‘wattless’ capacitor supply will not be able to provide sufficient current.

7 Increased I/O #1

A number of circuit modifications may require additional I/O pins which could be obtained by using the larger PIC16C55 processor. Alternatively, by using eight diodes, the house and unit address switches can be multiplexed onto the same four input pins. Using the circuit below when output RB2 is low and output RB3 is high switches 5-8 (house address) can be read on inputs RB4-RB7. When output RB3 is low and output RB2 is high switches 1-4 (unit address) can be read on inputs RB4-RB7. Now unused, I/O pins RB0 and RB1 are available.

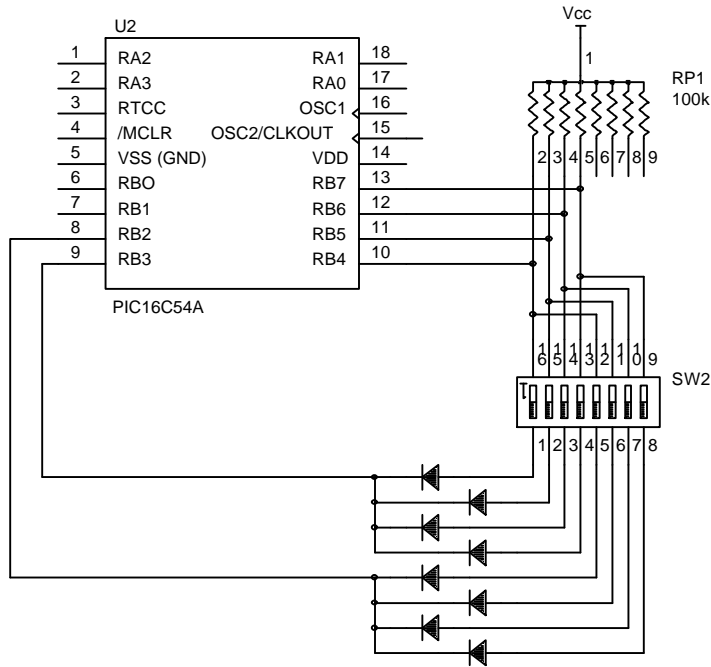

Applications such as garage door or window blind openers require limit switches. The extra I/O pins available could be used as switch inputs to sense when the door/blind had fully opened/closed and switch the motor off.

8 Increased I/O #2

Another way to increase I/O is to hard code the X-10 house/unit address into the PIC16C54 firmware. The eight pins used to read the address switch become available. Many modules once installed are never moved and so the inflexibility of a fixed address may not be a problem. The cost of PIC processors is quite low so the expense of replacing the processor is not prohibitive should the system ever be changed. Having dispensed with the address switch the processor could then be replaced by one of the new eight-pin PIC12C508 devices and still have two I/O pins spare!

9 Non-Standard Data Formats (X-10 heresy)

The power-line transmitter in the TW523 is quite unintelligent and relies on a control driver for all the X-10 data coding and timing. The driver may be a micro-processor (PL-Link, Marrick etc.) or software on a PC. In the later case there is no reason why the control driver code can not be modified to send non X-10 data. By changing the coding system a personal super-set of commands can be created. For example, the number of unit addresses could be increased. Security would be improved as non-standard coding would ensure that appliances would not respond to a neighbour trying all the codes on his new mini-controller or RF remote.

10 Raw X-10 Data Monitor

In developing the appliance module it was necessary to monitor the raw X-10 data on the power-line. Instead of driving a triac a prototype of the appliance module drove an opto-isolator with RS-232 data. At each zero crossing either an ASCII '0' or '1' was transmitted to indicate the absence or presence of the 120kHz carrier. Fed into a PC running a terminal program (Procomm) the resulting raw X-10 data was displayed and captured.

Useful Articles

The X-10 FAQ

periodically posted to comp.home.automation newsgroup
or from: <ftp://ftp.scruz.net/users/cichlid/public/x10faq>
or from: <http://www.homation.com>.

X-10 Powerhouse - Technical Note:

The X-10 Powerhouse Power Line Interface Model # PL513 and
Two-Way Power Line Interface #TW523
Revision 2.4 Dave Rye

SGS-Thomson ST6210/ST6215/ST6220/ST6225 data book

Application Note:

Micro-controller and Triacs on the 110/240V Mains

Electronics Today International - March 1996

Driving Triacs with the PIC Micro-controller - Bart Trepak

Everyday with Practical Electronics - February 1995

Transformerless Power Supplies - Andy Flind

Everyday Electronics - May 1989

Pet Scarer - Mark Stuart

Parts List

Quantity	Reference	Part	Comments
Semiconductors			
1	U1	4069UB	
1	U2	PIC16C54	
1	Q1	TIC206D	
1	D1	1N4007	
1	D2	C5V6 1.3W zener	
2	D3,D4	C6V8 400mW zener	
2	D5,D6	1N4148	
Capacitors			
1	C1	0.47u, 275V X2 rated	1.0u for 110VAC operation
1	C2	470u, 25V	
1	C3	0.1u, 275V X2 rated	
1	C4	33n	
2	C5,C6	150p, disc ceramic	
2	C7,C9	3n3	
2	C8,C10	4n7	
1	C11	100p, disc ceramic	
2	C12,C13	10p, disc ceramic	
1	C14	10n	
2	C15,C16	22p, disc ceramic	
1	C17	0.1u, disc ceramic	
Resistors			
1	R1	100, 0.5W	
1	R2	1M, 0.25W	
1	R3	10k, 0.25W	
1	R4	33k, 0.25W	
1	R5	10M, 0.25W	
1	R6	470k, 0.25W	
1	R7	220k, 0.25W	
1	R8	47k, 0.25W	
1	R9	100k, 0.25W	
1	R10	22k, 0.25W	
1	R11	4M7, 0.25W	2M2 for 110VAC operation
1	R12	330, 0.25W	
1	RP1	100k, 9-pin SIL R-pack	
Switches			
1	SW2	8PST DIP switch	
1	SW1	2-pin header to push-button switch , momentary make.	
Connectors			
2	J1,J2	3-way terminal block	
Miscellaneous			
1	X1	4MHz crystal	
1	VDR1	275V varistor	130V for 110VAC operation
1	TX1	Tuned transformer	Toko 707VXA042YUK
2	L1,L2	220uH axial inductor	
1	P.C.B.	As artwork	
1	Enclosure	As required	

Component Sourcing

Most components should not prove difficult to source. Suppliers of some of the less common parts are given below. The author designed the circuit board to mount inside a specific waterproof polycarbonate enclosure and the manual on-off push-button chosen was similarly rugged/expensive. If outdoor use is not required or the printed circuit board layout provided is not to be used then alternative components may be more appropriate. All suppliers listed are UK companies.

Item	Reference	Supplier	Stock Number
IP65 Enclosure		RS Components Ltd.	580-360
IP67 Push-button switch	SW1	RS Components Ltd.	321-234
Tuned transformer, Toko type 707VXA042YUK	TX1	MPS Maplin Professional or B.E.C. Distribution Ltd. or Cirkit Distribution Ltd.	FT55K 380042 35-70742
220uH axial inductor	L1,L2	RS Components Ltd. or Cirkit Distribution Ltd.	240-539 35-71224

B.E.C. Distribution Ltd.
12 Elder Way, Langley Business Park, Slough, Berks. SL3 6EP.
Tel. 01753 549502; Fax 01753 543812

Cirkit Distribution Ltd.
Park Lane, Broxbourne, Herts. EN10 7NQ
Tel 01992 448899; Fax 01992 471314.

MPS Maplin Professional
P.O. Box 777, Rayleigh, Essex, SS6 8LU
Tel. 01702 554000; Fax 01702 554001; <http://www.maplin.co.uk>

RS Components Ltd. (Not to be confused with Radio Shack)
P.O. Box 99, Corby, Northants, NN17 9RS.
Tel. 01536 201201; Fax 01536 201501; <http://www.rs-components.com/rs>

Source Code Listing

```
; X-10 Receiver
; Copyright Philip Charles Plunkett   ABACUS ELECTRICS   1996

; Client:                In House
; File Name:             X10RX128.ASM
; File Date:             16 August 1996
; Target Device:        PIC 16C54A
; Clock Type:           4MHz Xtal, 1uS Instruction Cycle
; Watchdog:             On
; Code Protection:      Off
; Customer ID Code:     'ABAC'
; Assembler:           MPASM version 1.30
; Code Revision:        1.28 First released version

        TITLE    "X-10 Receiver"

        LIST    P = 16C54

; Generic Definitions
W       EQU     H'0000'    ; Result Destination = W Register
F       EQU     H'0001'    ; Result Destination = F Register

; Standard Register Files
INDF    EQU     H'0000'    ; Indirect Addressing Register
RTCC    EQU     H'0001'    ; Counter
PC      EQU     H'0002'    ; Program Counter
STATUS  EQU     H'0003'    ; Status Register
FSR     EQU     H'0004'    ; File Select Register
PORT_A  EQU     H'0005'    ; Port A Input/Output Port
PORT_B  EQU     H'0006'    ; Port B Input/Output Port

; STATUS Register Bits
#define CARRY    STATUS, 0    ; Carry Bit
#define DIGCARRY STATUS, 1    ; Digit Carry Bit
#define ZERO     STATUS, 2    ; Zero Bit
#define NOT_PD   STATUS, 3    ; Power Down Bit
#define NOT_TO   STATUS, 4    ; Watchdog TimeOut Bit
#define PA0     STATUS, 5    ; Page Preselect
#define PA1     STATUS, 6    ; Page Preselect
#define PA2     STATUS, 7    ; Future use

; OPTION Register Bits
PS0     EQU     H'0000'    ; Prescaler divide ratio  Eight divide ratios:
PS1     EQU     H'0001'    ; Prescaler divide ratio  WDT 1:1 to 1:128
PS2     EQU     H'0002'    ; Prescaler divide ratio  RTCC 1:2 to 1:256
PSA     EQU     H'0003'    ; Prescaler Assignment    0=RTCC 1=WDT
RTE     EQU     H'0004'    ; RTCC Pin Signal Edge    0=Rising 1=Falling
RTS     EQU     H'0005'    ; RTCC Signal Source      0=Clock 1=RTCC Pin
```

```

; Fuse Definitions and Configurations
_CP_ON EQU H'0FF7'
_CP_OFF EQU H'0FFF'

_WDT_ON EQU H'0FFF'
_WDT_OFF EQU H'0FFB'

_LP_OSC EQU H'0FFC' ; 32kHz
_XT_OSC EQU H'0FFD' ; 100kHz - 4MHz
_HS_OSC EQU H'0FFE' ; 4MHz - 20MHz
_RC_OSC EQU H'0FFF' ; 100kHz - 4MHz

__FUSES _CP_OFF&_WDT_ON&_XT_OSC

__IDLOCS H'ABAC'

__MAXRAM H'01F'

; Input/Output Port Assignments

#define TRIAC PORT_A, 0 ; Triac Gate Drive
#define ZEROX PORT_A, 1 ; Zero-Crossing Detector Input
#define CARRIER PORT_A, 2 ; Mains Carrier Detect
#define BUTTON PORT_A, 3 ; Push Button Input

#define UNIT3 PORT_B, 0 ; Unit/Function Code 3
#define UNIT2 PORT_B, 1 ; Unit/Function Code 2
#define UNIT1 PORT_B, 2 ; Unit/Function Code 1
#define UNIT0 PORT_B, 3 ; Unit/Function Code 0
#define HOUSE0 PORT_B, 4 ; House Code 0 \
#define HOUSE1 PORT_B, 5 ; House Code 1 | 0 to 15
#define HOUSE2 PORT_B, 6 ; House Code 2 | re-assigned as
#define HOUSE3 PORT_B, 7 ; House Code 3 / A to 0

; Register File Variables
FLAGS EQU H'0008' ; Bits used as status flags
COUNT EQU H'0009' ; Counter used by Wait routines
HOUSE EQU H'000A' ; House code, 0 - 15 == A - P
UNIT EQU H'000B' ; Unit code, 0 - 15 == 1 - 16
RXHOUSE EQU H'000C' ; Received House code, 0 - 15 == A - P
RXUNIT EQU H'000D' ; Received Unit code, 0 - 15 == 1 - 16
RXFUNC EQU H'000E' ; Received Unit code, 0 - 15 == 1 - 16

#define LOAD FLAGS, 0 ; 0=Load is off, 1=Load is on

; Define Macros
TriacOn macro
    BCF TRIAC
endm

TriacOff macro
    BSF TRIAC
endm

GetBit macro locn
    CALL ReadBit
    RLF locn, F
endm

```

```

;X-10 COMMAND FORMAT
;
; start      unit      house      gap      house      start      function
; house      start      unit      start      function      house
;
;NB: Total of 94 zero-crossings used, 95 with ND561 (*)
; Control console/RF remote produce one extra blank half-cycle;
; (7 instead of 6) in gap:
;
;Control console ND561 via SH624 RF remote; sending A1 ON:
;
; 1110 01101001 0110100101 1110 01101001 0110100101 0000000>continued (*)
; 0 1 1 0 0 1 1 0 0 0 1 1 0 0 1 1 0 0 >
; S A 1 S A 1 GAP >
;
; >1110 01101001 0101100110 1110 01101001 0101100110
; > 0 1 1 0 0 0 1 0 1 0 1 1 0 0 0 1 0 1
; >S A ON S A ON DONE
;
;
;Mini-Controller MC563 or Mini-Timer MT522; sending C1 ON:
;
; 1110 01011001 0110100101 1110 01011001 0110100101 0000000>
; 0 0 1 0 0 1 1 0 0 0 0 1 0 0 1 1 0 0 >continued
; S C 1 S C 1 GAP >
;
; >1110 01011001 0101100110 1110 01011001 0101100110
; >0 0 1 0 0 0 1 0 1 0 0 1 0 0 0 1 0 1
; >S C ON S C ON DONE
;
;
; ORG 00H
;
; Program starting point
;
Start
    MOVLW B'00001110'
    TRIS PORT_A ; Set Port A as Inputs & Outputs

    MOVLW B'11111111'
    TRIS PORT_B ; Set Port B as Inputs

    TriacOff ; Set Load off
    CLRF FLAGS
    CLRF HOUSE
    CLRF UNIT
    CLRF RXHOUSE
    CLRF RXUNIT
    CLRF COUNT

    MOVLW B'00000111' ; RTCC Prescaler, divide by 256
    OPTION ; gives 256uS per count

```

```

MainLoop
    CALL    Wait500mSec

Wait1110A
    CLRWDT

    BTFSS  LOAD           ; Continuously re-assert load status
    TriacOff
    BTFSC  LOAD
    TriacOn

    BTFSS  BUTTON        ; Check if manual button pressed,
    GOTO   Manual         ; if so do manual routines

    CALL   ReadBit        ; Wait for Start Sequence 1110
    BTFSS  CARRY          ; 1
    GOTO   Wait1110A
    CALL   ReadBit
    BTFSS  CARRY          ; 1
    GOTO   Wait1110A
    CALL   ReadBit
    BTFSS  CARRY          ; 1
    GOTO   Wait1110A
    CALL   ReadBit
    BTFSC  CARRY          ; 0
    GOTO   Wait1110A

    GetBit RXHOUSE        ; Read first house address
    GetBit RXHOUSE
    GetBit RXHOUSE
    GetBit RXHOUSE
    GetBit RXHOUSE
    GetBit RXHOUSE
    GetBit RXHOUSE
    GetBit RXHOUSE

    GetBit RXUNIT        ; Read first unit address
    GetBit RXUNIT
    GetBit RXUNIT
    GetBit RXUNIT
    GetBit RXUNIT
    GetBit RXUNIT
    GetBit RXUNIT
    GetBit RXUNIT        ; ignore last two bits
    GetBit RXUNIT        ; as always 0 1 == 0

    MOVLW  D'0024'        ; wait 24 zero-crossings, ie
    MOVWF  COUNT          ; to start of 'gap'

BitCount1
    CALL   ReadBit
    DECFSZ COUNT, F
    GOTO   BitCount1

    MOVLW  D'0011'        ; wait a maximum of 10 zero-crossings
    MOVWF  COUNT          ; for next start sequence

Wait1110B
    DECFSZ COUNT, F
    GOTO   W1110B
    GOTO   MainLoop        ; Abort as problem with data sequence

```

```

W1110B
    CLRWDT
    CALL  ReadBit      ; Re-synchronise with pre-function
    BTFSS CARRY       ; 1 start sequence
    GOTO  Wait1110B
    CALL  ReadBit
    BTFSS CARRY       ; 1 Can not just count bits as gap
    GOTO  Wait1110B   ; length varies with transmitter type
    CALL  ReadBit
    BTFSS CARRY       ; 1
    GOTO  Wait1110B
    CALL  ReadBit
    BTFSS CARRY       ; 0
    GOTO  Wait1110B

    MOVLW D'0008'     ; ignore next 8 bits =
    MOVWF COUNT       ; house address again

BitCount2
    CALL  ReadBit
    DECFSZ COUNT, F
    GOTO  BitCount2

    GetBit RXFUNC     ; Read command function
    GetBit RXFUNC
    GetBit RXFUNC
    GetBit RXFUNC
    GetBit RXFUNC     ; ignore last two bits of function
    GetBit RXFUNC     ; as always 1 0 == 1
    GetBit RXFUNC
    GetBit RXFUNC     ; and ignore rest of data (22 bits)

    CALL  ReadDIPSwitches
    MOVF  HOUSE, W
    SUBWF RXHOUSE, W
    XORLW 0
    BZ    GoodHouse
    GOTO  MainLoop

GoodHouse
    MOVF  UNIT, W     ; Received House code matches DIP switch
    SUBWF RXUNIT, W
    XORLW 0
    BZ    GoodUnit
    GOTO  MainLoop

GoodUnit
    MOVLW B'01011001' ; Received Unit code matches DIP switch
    SUBWF RXFUNC, W   ; On function 0010 1
    XORLW 0
    BZ    PowerOn1
    MOVLW B'01011010' ; Off function 0011 1
    SUBWF RXFUNC, W
    XORLW 0
    BZ    PowerOff1
    GOTO  MainLoop

PowerOn1
    TriacOn
    BSF  LOAD
    GOTO MainLoop

PowerOff1
    TriacOff
    BCF  LOAD
    GOTO MainLoop

```

```

Manual
    CALL    Wait100mSec ; Manual operation, de-bounce switch
           ; by reading again after a delay.
    BTFSC  BUTTON      ; Re-check if manual button pressed.
    GOTO   MainLoop
    BTFSS  LOAD
    GOTO   PowerOn2

Poweroff2
    CLRWDI
    TriacOff ; Manual switch load off
    BCF    LOAD ; Clear 'load on' flag
    BTFSS  BUTTON ; Wait here until button released
    GOTO   Poweroff2
    GOTO   MainLoop

PowerOn2
    CLRWDI
    TriacOn ; Manual switch load on
    BSF    LOAD ; Set 'load on' flag
    BTFSS  BUTTON ; Wait here until button released
    GOTO   PowerOn2
    GOTO   MainLoop

ReadBit
    CALL    ZeroCross ; Call & return after zero crossing
    CALL    Wait250uSec ; Wait so sample into carrier burst
    BTFSS  CARRIER ; Check for presence of 120kHz carrier
    GOTO   GB1
    BSF    CARRY ; Carrier present so set carry flag
    RETLW  0

GB1
    BCF    CARRY ; Carrier absent so clear carry flag
    RETLW  0

ZeroCross
    BTFSC  ZEROX ; Check present +ve/-ve status of 50Hz
    GOTO   Z1 ; power then wait for it to change

Z0
    CLRWDI ; Is low
    BTFSS  ZEROX ; Loop until goes high
    GOTO   Z0
    RETLW  0

Z1
    CLRWDI ; Is high
    BTFSC  ZEROX ; Loop until goes low
    GOTO   Z1
    RETLW  0

Wait100mSec
    MOVLW  D'0006' ; 6 x 16.384msec = 98.304msec
    MOVWF  COUNT
    GOTO   WaitLoop

Wait500mSec
    MOVLW  D'0030' ; 30 x 16.384msec = 491.52msec
    MOVWF  COUNT

WaitLoop
    MOVLW  D'0192' ; 256-64=192, 64 x 256usec = 16.384msec
    MOVWF  RTCC ; Time delay inner loop

Wait16
    CLRWDI
    MOVF   RTCC, W
    BNZ    Wait16

    DECFSZ COUNT, F
    GOTO   WaitLoop
    RETLW  0

Wait250uSec
    CLRF   RTCC

W0
    CLRWDI ; Measured at about 273uSecs
    MOVF   RTCC, W
    BZ     W0
    RETLW  0

```



```

ReadDIPSwitches
    SWAPF PORT_B, W      ; Read DIP switch high nibble = house address
    MOVWF HOUSE         ; and complement for true-logic
    COMF HOUSE, W       ; Save in HOUSE variable
    ANDLW H'000F'       ; 0 -> 15 == A -> P
    CALL HouseTable     ; Look up bit pattern
    MOVWF HOUSE
    MOVF PORT_B, W      ; Read DIP switch low nibble = unit address
    ANDLW H'000F'       ; Unscramble bits and complement for true-logic
    CALL UnitTable      ; Look up bit pattern & save in UNIT variable
    MOVWF UNIT          ; 0 -> 15 == 1 -> 16
    RETLW 0

HouseTable
    ADDWF PC, F         ; House Code Look-up table:
    RETLW B'01101001'  ; A = 0110
    RETLW B'10101001'  ; B = 1110
    RETLW B'01011001'  ; C = 0010
    RETLW B'10011001'  ; D = 1010
    RETLW B'01010110'  ; E = 0001
    RETLW B'10010110'  ; F = 1001
    RETLW B'01100110'  ; G = 0101
    RETLW B'10100110'  ; H = 1101
    RETLW B'01101010'  ; I = 0111
    RETLW B'10101010'  ; J = 1111
    RETLW B'01011010'  ; K = 0011
    RETLW B'10011010'  ; L = 1011
    RETLW B'01010101'  ; M = 0000
    RETLW B'10010101'  ; N = 1000
    RETLW B'01100101'  ; O = 0100
    RETLW B'10100101'  ; P = 1100

UnitTable
    ADDWF PC, F         ; Unit Code Look-up table:
    RETLW B'10100101'  ;0>0>F = 16 = 1100 0   Flips bits 0 with 3,
    RETLW B'10100110'  ;1>8>7 = 8 = 1101 0   and 1 with 2 and
    RETLW B'10011010'  ;2>4>B = 12 = 1011 0   then complements result.
    RETLW B'10011001'  ;3>C>3 = 4 = 1010 0   Bits must be twisted
    RETLW B'10010101'  ;4>2>D = 14 = 1000 0   to undo twisting
    RETLW B'10010110'  ;5>A>5 = 6 = 1001 0   on PCB layout.
    RETLW B'10101010'  ;6>6>9 = 10 = 1111 0
    RETLW B'10101001'  ;7>E>1 = 2 = 1110 0
    RETLW B'01100101'  ;8>1>E = 15 = 0100 0
    RETLW B'01100110'  ;9>9>6 = 7 = 0101 0
    RETLW B'01011010'  ;A>5>A = 11 = 0011 0
    RETLW B'01011001'  ;B>D>2 = 3 = 0010 0
    RETLW B'01010101'  ;C>3>C = 13 = 0000 0
    RETLW B'01010110'  ;D>B>4 = 5 = 0001 0
    RETLW B'01101010'  ;E>7>8 = 9 = 0111 0
    RETLW B'01101001'  ;F>F>0 = 1 = 0110 0

    ORG 1FFH
    GOTO Start          ; RESET vector

END

```

Note:
For 115 VAC Operation

VDR1 = 130 V
C1 = 1u
R11 = 2M2

