

## GPS Receivers A1029

A description of Tyco Electronics' GPS modules A1029-A and A1029-B including Dead Reckoning interface

### User's Manual

Version 3.2  
Hardware Revision 03

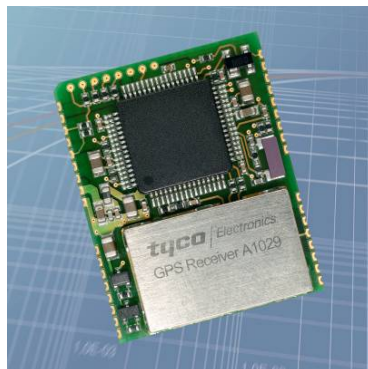

**tyco**

*Electronics*

This page was intentionally left blank.

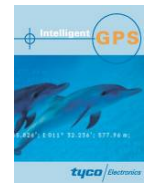

## Revision History

Rev.	Date	Description
1.0	11-10-03	Initial Draft.
1.1	11-24-03	Second draft – not released.
1.2	12-02-03	Preliminary version.
1.3	12-22-03	Minor format changes.
1.4	01-09-04	Gain select clarified, LOCK pin described, Overview Mechanics included.
1.5	01-15-04	Picture, description ENABLE pin.
1.6	02-16-04	Included picture minimum configuration.
1.7	03-01-04	Included antenna connection recommendations, tape drawings, removed Glossary (on web site).
1.8	04-15-04	Included solder pad proposal.
1.9	06-18-04	Complete review, important changes on VANT and 1PPS.
2.0	06-23-04	Introduced A1029-B.
2.1	07-16-04	Minor corrections after R&D review.
2.2	10-06-04	Minor corrections.
2.3	10-11-04	Format changes, correct pin-out of A1029B, added tray description on A1029-B.
2.4	02-23-05	Introduced new contact details.
3.0	07-01-05	Description of additional Dead Reckoning signal interface (HW version 02), added details for use of nRST signal.
3.1	11-10-05	Description of differences HW version 02 to old HW version 01 for A1029-A added.
3.2	02-17-06	More details added for signals.
3.2	03-03-06	Recommended minimum Configuration updated
	mm-dd-yy	

## Disclaimer

THIS DOCUMENT CONTAINS PROPRIETARY INFORMATION OF TYCO ELECTRONICS CORPORATION/POWER SYSTEMS (TYCO ELECTRONICS). IT MAY NOT BE COPIED OR TRANSMITTED BY ANY MEANS, PASSED TO OTHERS, OR STORED IN ANY RETRIEVAL SYSTEM OR MEDIA, WITHOUT PRIOR CONSENT OF TYCO ELECTRONICS OR ITS AUTHORIZED AGENTS.

THE INFORMATION IN THIS DOCUMENT IS, TO THE BEST OF OUR KNOWLEDGE, ENTIRELY CORRECT. HOWEVER, TYCO ELECTRONICS CAN NEITHER ACCEPT LIABILITY FOR ANY INACCURACIES, OR THE CONSEQUENCES THEREOF, NOR FOR ANY LIABILITY ARISING FROM THE USE OR APPLICATION OF ANY CIRCUIT, PRODUCT, OR EXAMPLE SHOWN IN THE DOCUMENT.

THE PRODUCT (HARD- AND SOFTWARE) DESCRIBED IN THIS DOCUMENTATION IS NOT AUTHORIZED FOR USE IN LIFE SUPPORT DEVICES OR SYSTEMS WITHOUT THE EXPRESS WRITTEN APPROVAL OF TYCO ELECTRONICS.

THIS DOCUMENT MAY PROVIDE LINKS TO OTHER WORLD WIDE WEB SITES OR RESOURCES. BECAUSE TYCO ELECTRONICS HAS NO CONTROL OVER SUCH SITES AND RESOURCES, TYCO ELECTRONICS SHALL NOT BE RESPONSIBLE FOR THE AVAILABILITY OF SUCH EXTERNAL SITES OR RESOURCES, AND DOES NOT ENDORSE AND IS NOT RESPONSIBLE OR LIABLE FOR ANY CONTENT, ADVERTISING, PRODUCTS, OR OTHER MATERIALS ON OR AVAILABLE FROM SUCH SITES OR RESOURCES. TYCO ELECTRONICS SHALL NOT BE RESPONSIBLE OR LIABLE, DIRECTLY OR INDIRECTLY, FOR ANY DAMAGE OR LOSS CAUSED OR ALLEGED TO BE CAUSED BY OR IN CONNECTION WITH USE OF OR RELIANCE ON ANY SUCH CONTENT, GOODS OR SERVICES AVAILABLE ON OR THROUGH ANY SUCH SITE OR RESOURCE.

TYCO ELECTRONICS RESERVES THE RIGHT TO CHANGE, MODIFY, OR IMPROVE THIS DOCUMENT OR THE PRODUCT DESCRIBED HEREIN, AS SEEN FIT BY TYCO ELECTRONICS WITHOUT FURTHER NOTICE.



## Table of Contents

<b>1 Introduction</b> .....	<b>7</b>
1.1 Dead Reckoning .....	7
1.2 Label .....	8
1.3 Characteristics .....	8
1.4 Handling Precautions .....	9
<b>2 Ordering Information</b> .....	<b>10</b>
2.1 GPS Receiver A1029-A and A1029-B .....	10
2.2 Packing .....	10
2.2.1 Packaging of the A1029-A .....	10
2.2.2 Packaging of the A1029-B .....	11
2.3 Additional Equipment .....	12
<b>3 Quick Start</b> .....	<b>13</b>
3.1 Minimum Configuration .....	13
3.2 Antenna .....	14
3.3 Serial Port Settings .....	14
3.4 Improved TTFF .....	14
<b>4 Mechanical Outline</b> .....	<b>15</b>
4.1 Overview A1029-A .....	15
4.1.1 Overall module dimensions .....	15
4.1.2 Details Component Side A1029-A .....	16
4.1.3 Details Solder Side A1029-A .....	17
4.2 Overview A1029-B .....	18
4.2.1 Overall module dimensions .....	18
4.2.2 Connector A1029-B .....	18
<b>5 Pin-out Information</b> .....	<b>19</b>
5.1 Layout A1029-A .....	19
5.2 Description A1029-A Signals .....	20
5.3 Layout A1029-B .....	22
5.4 Description A1029-B Signals .....	23
5.5 General Comments .....	24
<b>6 Dead Reckoning Interface</b> .....	<b>25</b>
6.1 Odometer and Reverse Signals .....	25
6.2 Gyro and Gyro Signal .....	26
6.3 Power Supply for Internal ADC .....	28
<b>7 Electrical Characteristics</b> .....	<b>29</b>
7.1 Operating Conditions .....	29
7.2 Absolute Maximum Ratings .....	29
<b>8 Mounting</b> .....	<b>30</b>
8.1 Proposed Footprint for Soldering .....	30

8.2 Recommended Profile for Reflow Soldering.....	31
<b>9 Use of Antenna.....</b>	<b>32</b>
9.1 Connection of RF Signal.....	32
9.2 Active Antenna.....	33
9.3 Passive Antenna.....	33
<b>10 Quality and Reliability.....</b>	<b>34</b>
10.1 Environmental Conditions.....	34
10.2 Product Qualification.....	34
10.3 Production Test.....	34
<b>11 Applications and Hints.....</b>	<b>35</b>
11.1 Minimum Configuration.....	35
11.2 Antenna Sensor Pin (ANTSTAT).....	35
11.3 Gain select pin (GS).....	35
11.4 VANT pin (antenna voltage input pin).....	36
11.5 LOCK pin (position fix pin).....	36
11.6 ENABLE pin (low-power mode).....	36
11.7 1PPS pin (1 pulse per second pin).....	36
11.8 Reset Signal.....	37
<b>12 Application Firmware.....</b>	<b>38</b>
<b>13 Demonstration Kits.....</b>	<b>39</b>
13.1 USB Kit A1029-A.....	39
13.2 Evaluation Kit A1029-A.....	39
13.3 Demonstration Kit A1029-B.....	39
<b>14 Related Information.....</b>	<b>40</b>
14.1 Contact.....	40
14.2 Related Documents.....	40
<b>15 List of Tables.....</b>	<b>43</b>
<b>16 List of Figures.....</b>	<b>43</b>

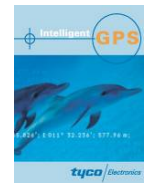

## 1 Introduction

Tyco Electronics' GPS module A1029-A is a highly integrated GPS receiver module and can be used as an SMT component. It also serves as the basis for the GPS module A1029-B, which is a plug-in module. Both modules are capable of receiving signals from up to 12 GPS satellites and transferring them into position and timing information that can be read over a serial port. The A1029-A and A1029-B extend Tyco Electronics' GPS receiver family, already represented by the A1021 and A1025. This new generation of GPS modules combines small size and high-end GPS functionality at low power consumption:

- Operable at 3.3V / 50mA (typ.) @ 1fix per second
- Antenna sensor pin with defined current sensing range (for antenna detection or antenna short circuit detection)
- LNA Gain select pin (for adjustment to various RF signal conditions)

A1029-A features:

- Small form factor of 22 x 28 mm (0.87" x 1.10")
- Cost-effective antenna input
- Single-sided SMD component, for reflow soldering
- Tape & reel packaging

A1029-B features:

- Standard power and I/O connector
- Standard SMA bulk head antenna connector
- Mountable without solder process
- Field replaceable

Both GPS receiver are available as off-the-shelf components, 100% tested and shipped in either standard tape-and-reel package (A1029-A) or in trays (A1029-B).

### 1.1 Dead Reckoning

Dead Reckoning capability was introduced with hardware version 02, which can be identified on the label. The extensions for the support of Dead Reckoning do not affect any other characteristics of the module. 100% backward electrical and mechanical compatibility is assured with one exception: In order to be able to support all necessary signals, the I/O connector of the A1029-B was extended by two pins on each side (total of 4 pins) keeping the center pins (signals and position) identical. Therefore the connector plugs into existing designs based on the hardware version 01. Care must be taken that the real estate now covered by the additional pins is not populated on the carrier PCB.

## 1.2 Label

The A1029's labels hold the following information:

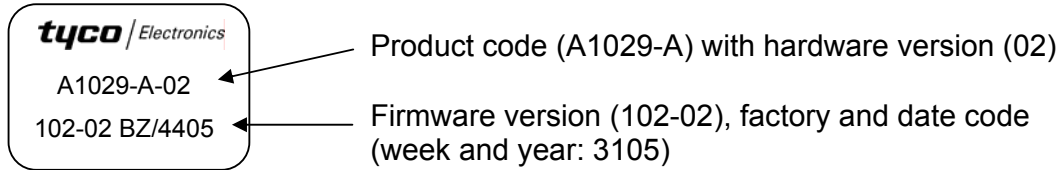

Figure 1: A1029 label

## 1.3 Characteristics

The modules are characterized by the following parameters.

Channels		12, parallel tracking
Frequency		L1 (= 1575 MHz)
Position Accuracy	Stand alone	3m CEP (SA off)
	Differential	< 2m CEP
Time To First Fix – TTFF (theoretical minimum values; values in real world may differ)	Obscuration recovery <sup>(1)</sup>	1s
	Hot start <sup>(2)</sup>	< 3s
	Warm <sup>(3)</sup>	< 32s
	Autonomous / cold <sup>(4)(6)</sup>	< 60s
	Power-off start <sup>(5)(6)</sup>	Varying

Table 1: A1029 characteristics

- (1) The calibrated clock of the receiver has not stopped, thus it knows precise time (to the  $\mu$ s level).
- (2) The receiver has estimates of time/date/position and valid almanac and ephemeris data.
- (3) The receiver has estimates of time/date/position and recent almanac.
- (4) The receiver has no estimate of time/date/position, and no recent almanac.
- (5) Receiver is powered off, clock stops. Start-up time depends on time passed since power-off and power-on location.
- (6) In order to improve TTFF, the receiver allows setting of time/date/position.

A1029-A Mechanical dimensions	Length	28mm, 1.10"
	Width	22mm, 0.87"
	Height	3.2mm, 0.12"
A1029-A Weight		2g, < 0.1oz

A1029-B Mechanical dimensions	Length	33.0mm, 1.3"
	Width	45.7mm, 1.8"
	Height	4.5mm, 0.18"
A1029-B Cable	Length	~100mm, ~4.0"
A1029-B Weight		11g, 0.5oz

Table 2 and 3: A1029-A and A1029-B dimensions and weight



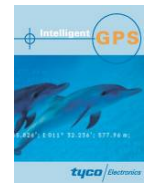

## 1.4 Handling Precautions

The GPS receiver modules A1029-A and A1029-B are modules that are sensitive to electrostatic discharge (ESD). Please handle with appropriate care.

## 2 Ordering Information

### 2.1 GPS Receiver A1029-A and A1029-B

The order numbers are built as follows:

- V23993A1029Axxx
- V23993A1029Bxxx

V23993 stands for Tyco Electronics wireless and communication products, A1029A for the A1029-A module, A1029B for the A1029-B module, respectively. The “xxx” stands for the according firmware version. Where

- “1xx” is standard GPS software
- “2xx” is GPS software with Dead Reckoning support

The functionality of both software versions is reflected in the according manuals.

## 2.2 Packing

### 2.2.1 Packaging of the A1029-A

The A1029-A GPS module comes in a tape and reel package suitable for pick and place machines.

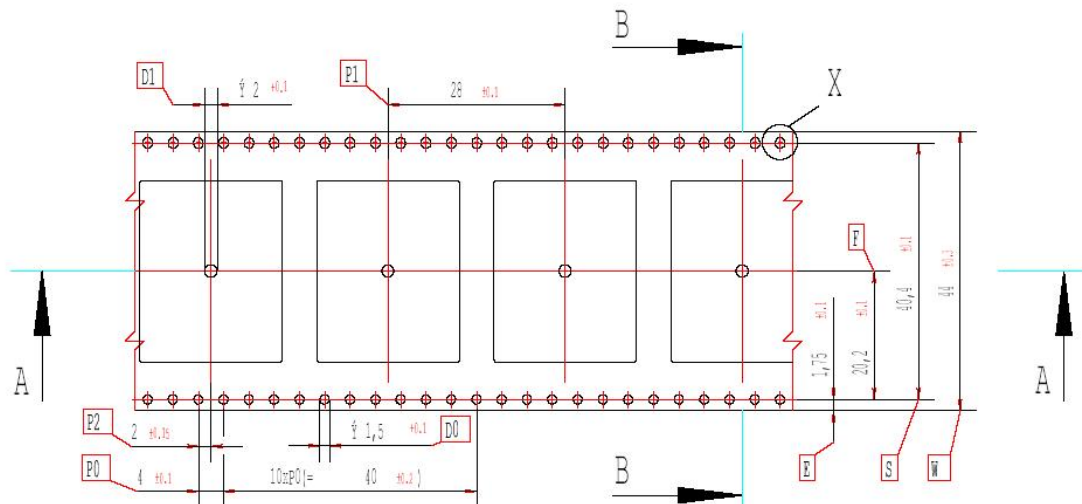

Figure 2: A1029-A tape specifications (1)

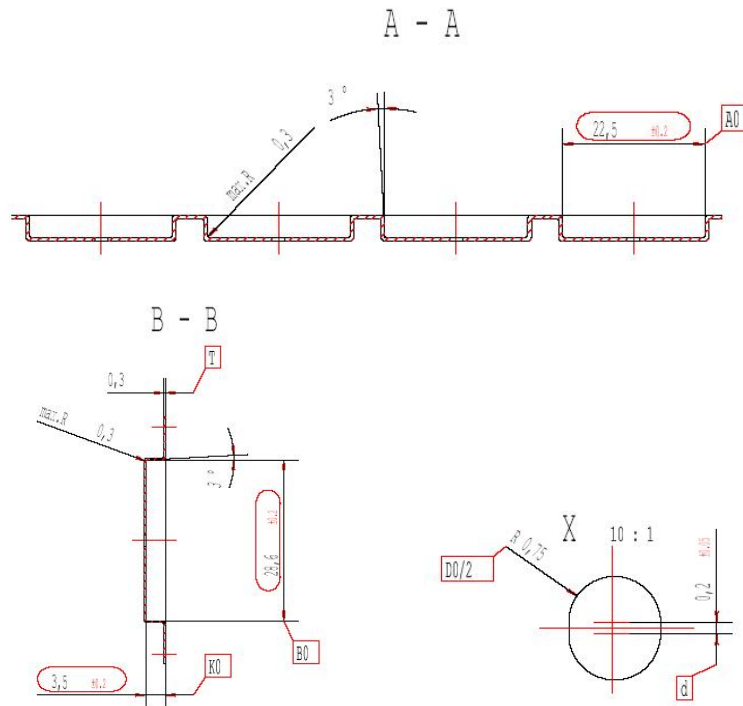
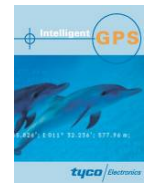

Figure 3: A1029-A tape specifications (2)

### 2.2.2 Packaging of the A1029-B

The A1029-B comes in trays, with 12 modules per tray.

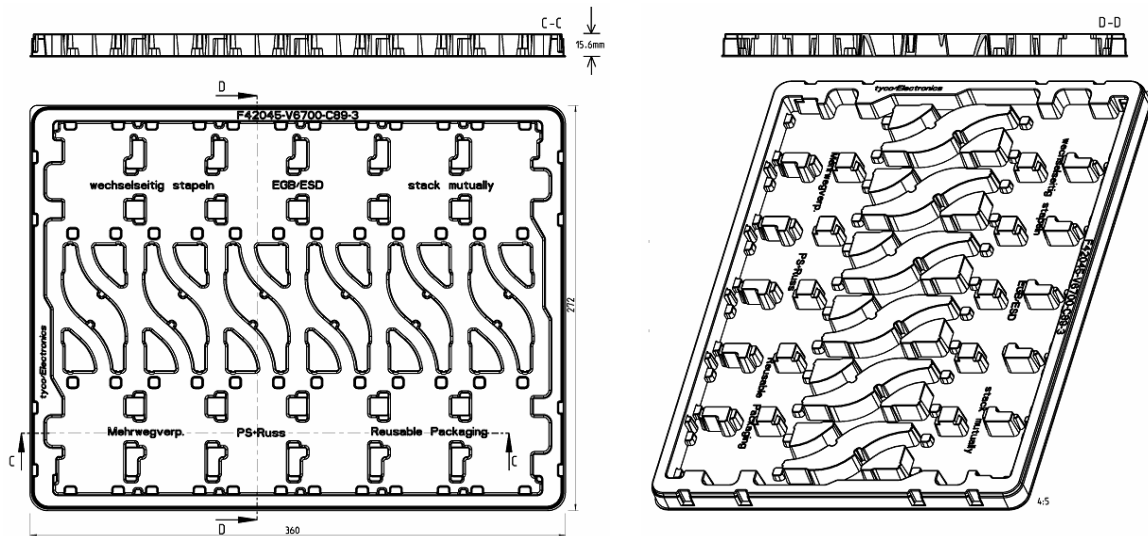

Figure 4: A1029-B tray specification

### 2.3 Additional Equipment

V23993USB1029A	Demonstration Kit (including one module V23993A1029A)
V23993EVA1029A	Evaluation Kit (including one module V23993A1029A)
V23993DKS1029B	Demonstration Kit (including one module V23993A1029B)
V23993DR1030A	Dead Reckoning Demonstration Kit (including one module V23993A1030B) – functionality compatible to A1029A/B Dead Reckoning solution.

Table 4: Additional equipment

Detailed descriptions of the additional kits can be found in the according manuals.

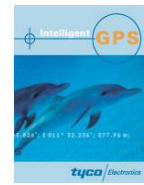

### 3 Quick Start

In order to allow an easy and quick start with the modules A1029-A or A1029-B, this chapter provides a short overview on the most important steps to receive NMEA messages with position information on a serial port. For details please refer to the according chapters.

#### 3.1 Minimum Configuration

The following picture shows a recommended minimum configuration for NMEA output and commands received and sent via an RS232 interface based on the A1029-A. The configuration for the A1029-B has to be set up accordingly, using the same pins on the module. Here it is not necessary to provide an antenna connection on the motherboard, as a cable and connector is already provided with the module itself.

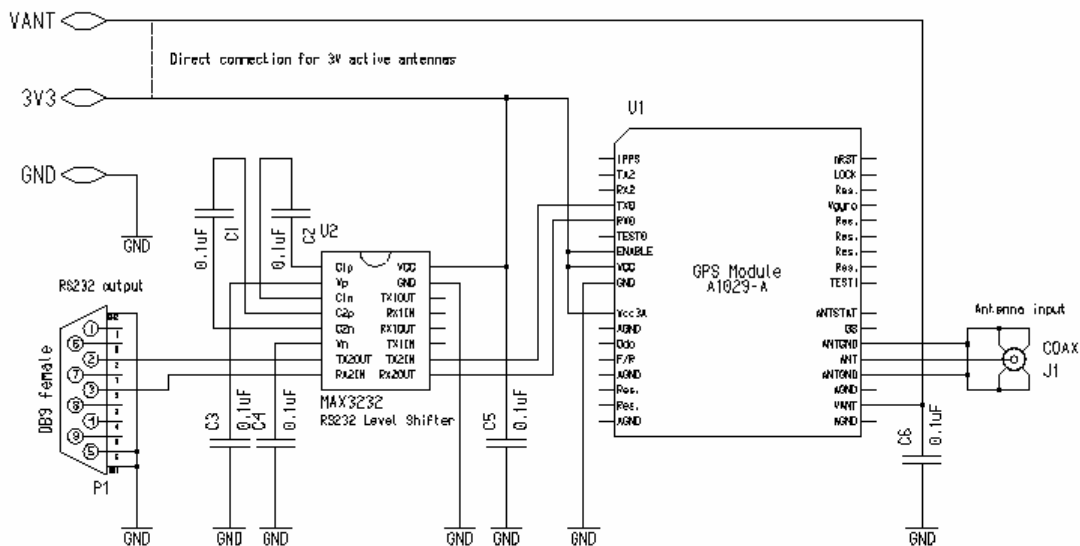

Figure 5: Recommended minimum configuration A1029-A

#### Remarks:

- Place C1 to C5 close to MAX3232. For capacity values see datasheet of actual component used.
- Place C6 close to module pin.
- Use 3.3V level shifter (MAX3232 or equivalent).
- Use separate ground plane for antenna ground.
- Antenna input impedance is 50Ohm. Match as close as possible.
- Maximum allowed antenna current is 50mA. Consider a current limiter.

- A battery back-up circuit for the RTC (Real Time Clock) should be considered (see below)!

### **3.2 Antenna**

It is recommended to use an active GPS antenna with supply voltage of 3 to 5VDC and a current draw of 50mA maximum. The quality of the GPS antenna chosen is of paramount importance for the overall sensitivity of the GPS system. An active antenna should have a gain  $\geq 20\text{dB}$  and a noise figure  $\leq 1.5\text{dB}$ , which applies to more than 95% of the active antennas available in the market.

### **3.3 Serial Port Settings**

The default configuration within the standard GPS firmware is:

- Serial 0 (NMEA) 4800 baud, 8 data bits, no parity, 1 stop bit, no flow control
- Serial 2 (RTCM) 4800 baud, 8 data bits, no parity, 1 stop bit, no flow control

The default configuration within the Dead Reckoning GPS firmware is:

- Serial 0 (NMEA) 57600 baud, 8 data bits, no parity, 1 stop bit, no flow control
- Serial 2 (RTCM) 4800 baud, 8 data bits, no parity, 1 stop bit, no flow control

### **3.4 Improved TTFF**

In order to improve the TTFF (Time To First Fix), it is recommended to support the RTC with a back-up battery when no system power is available. Standard operation mode is entered with the ENABLE pin on HIGH level. With the ENABLE pin on LOW level, low power mode will be entered. If still power is being supplied to Vcc, the RTC keeps on running while the internal processors will be stopped. The power consumption will drop from typically 50mA to typically 30 $\mu\text{A}$ . Please see also paragraph 11.6 ENABLE pin (low-power mode) and the documentation on the Evaluation Kit (EVA1029A).

If the system or the GPS receiver alone should not be backed-up it is possible to support the restart procedure by providing position and date/time information to the module. This is described in the firmware manual. Please refer there to chapter Start-up Support in the document T.E. GPS Firmware A1029 with version number V1.0 or higher.

## 4 Mechanical Outline

### 4.1 Overview A1029-A

#### 4.1.1 Overall module dimensions

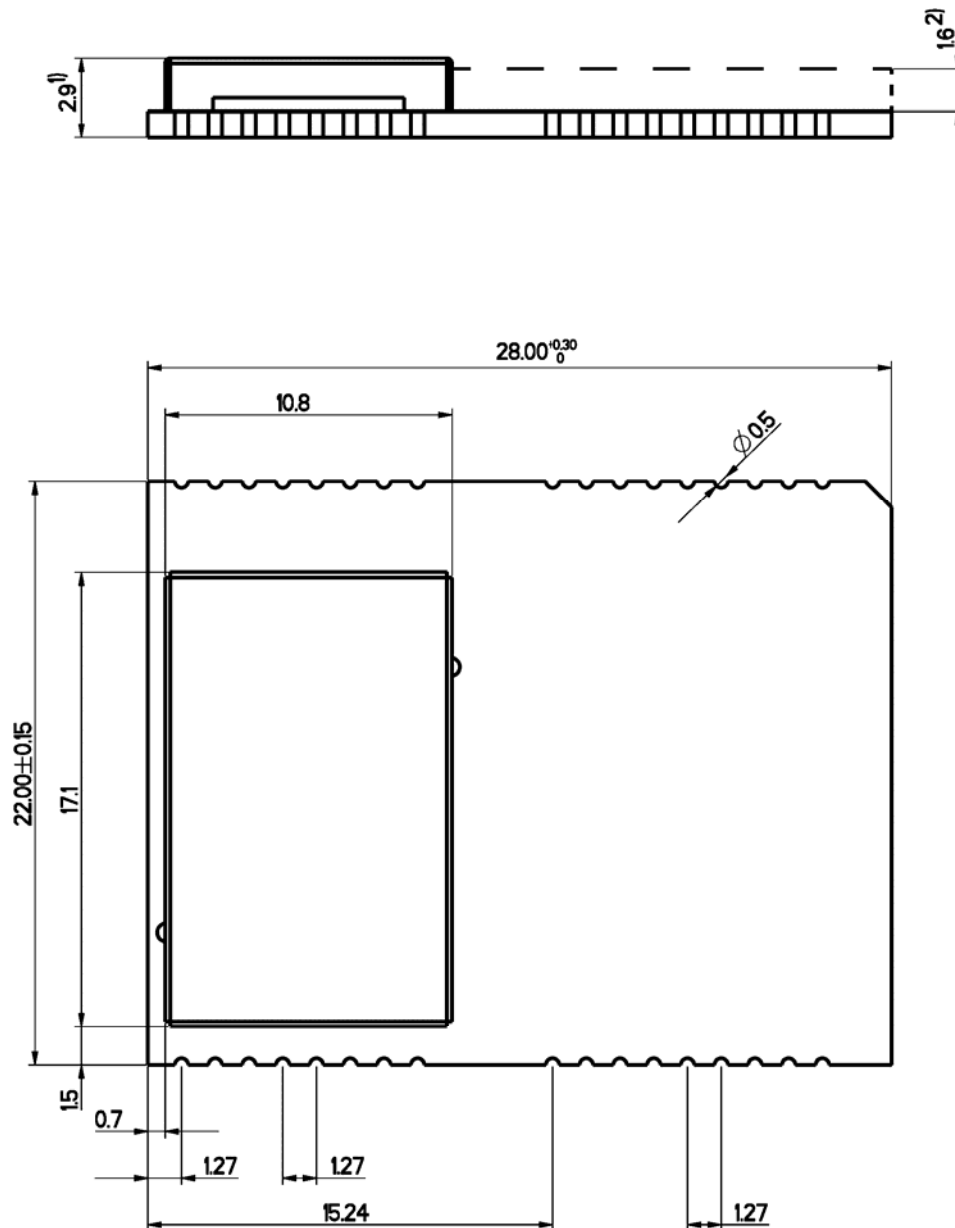

All dimensions in [mm], 1) Minimum, 2) Maximum

Figure 6: Mechanical outline overview A1029-A

### 4.1.2 Details Component Side A1029-A

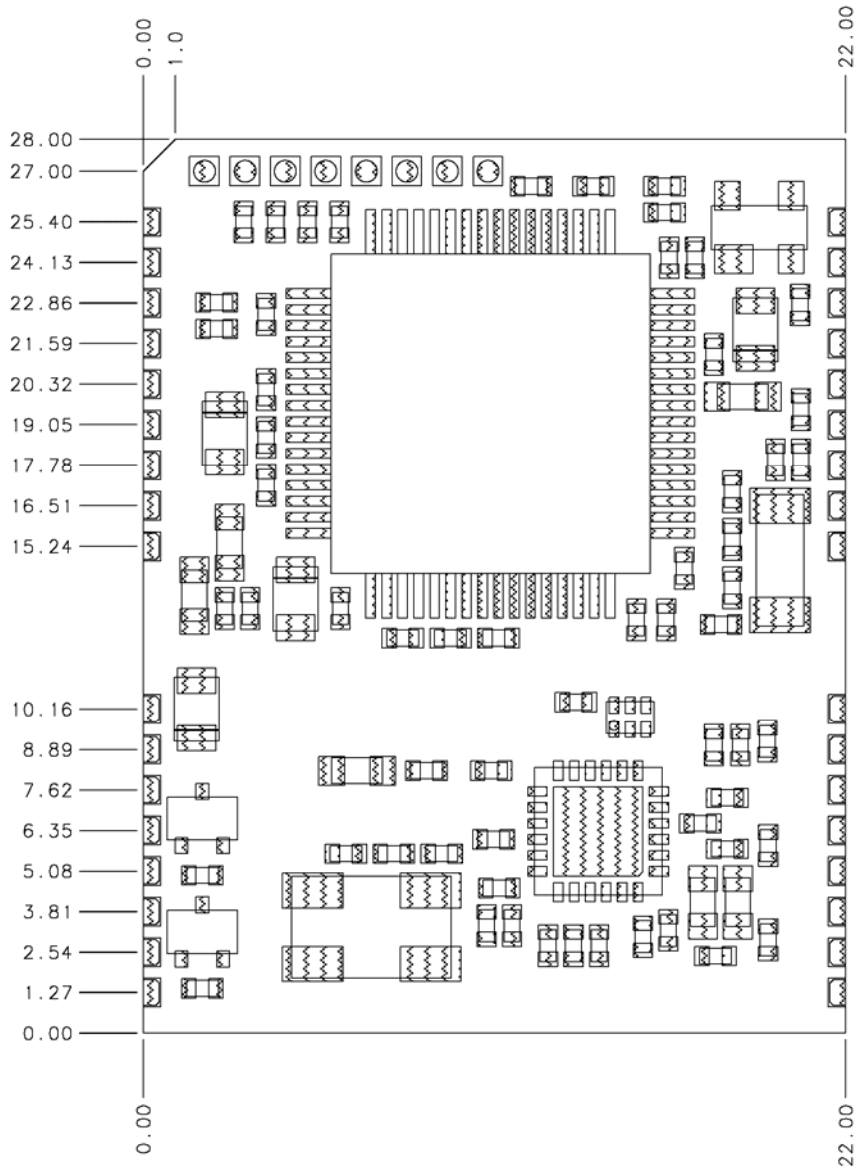

All dimensions in [mm]

Figure 7: Mechanical outline component side A1029-A



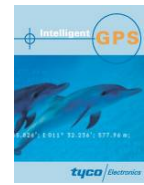

### 4.1.3 Details Solder Side A1029-A

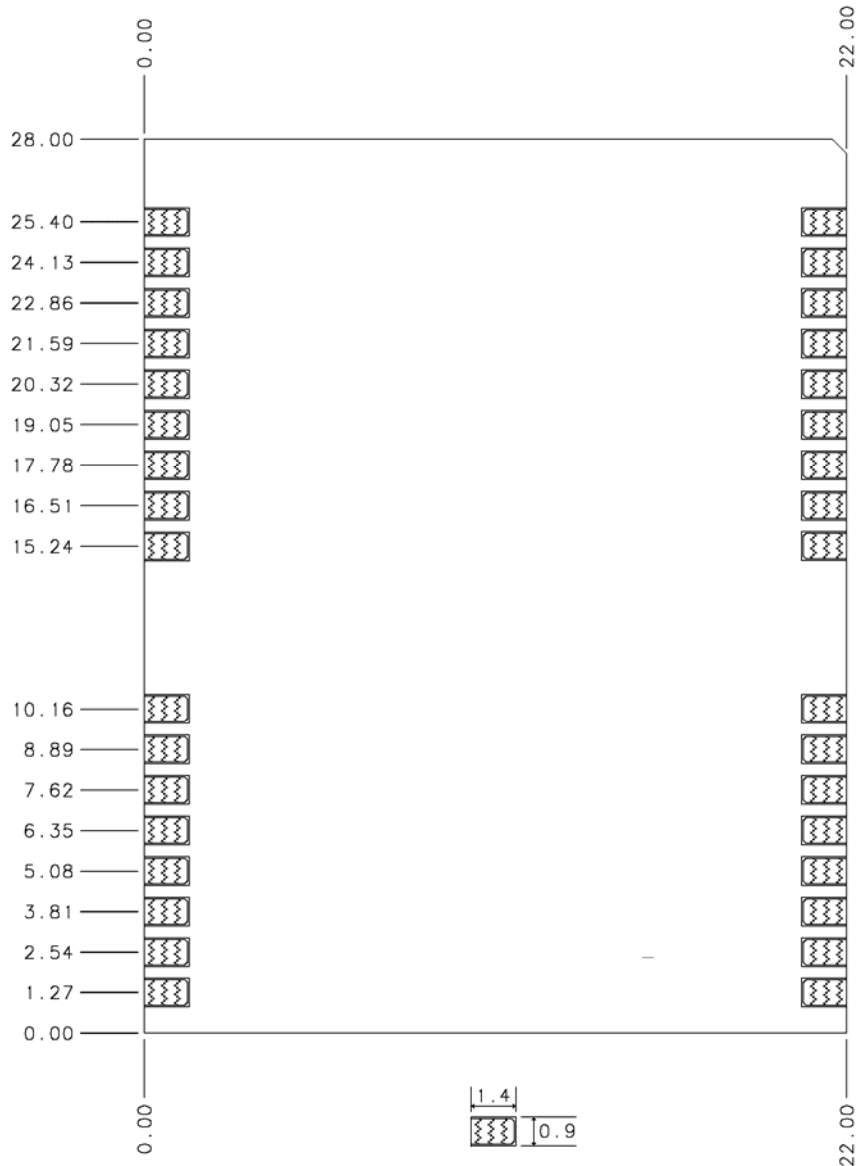

Solder pad size: 1.4 x 0.9  
 Width including solder pads: 22  
 Distance between solder pads within groups 1-9, 10-17, 18-25, 26-34: 1.27  
 Distance between groups (1-9 to 10-17 and 18-25 to 26-34): 5.08  
 All dimensions in [mm]

Figure 8: Mechanical outline solder side A1029-A

## 4.2 Overview A1029-B

### 4.2.1 Overall module dimensions

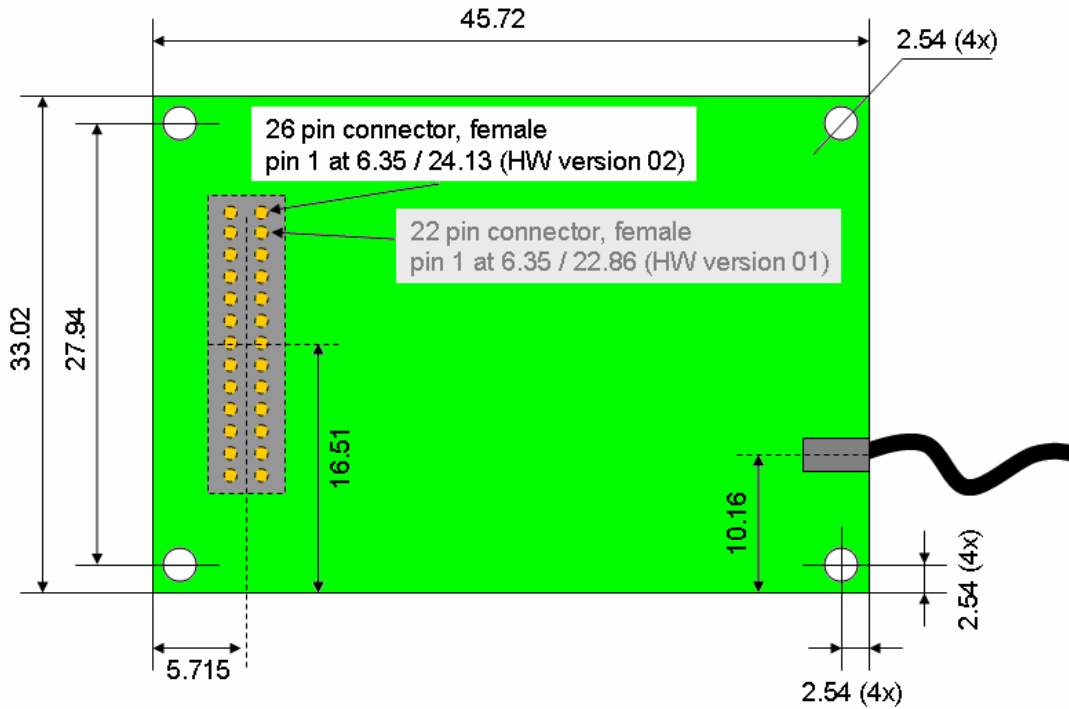

All dimensions in [mm]

Figure 9: Mechanical outline overview A1029-B

### 4.2.2 Connector A1029-B

The power and I/O connector used on the A1029-B is a 1.27mm (0.05") low profile, double row socket with a height of 2.21mm (.087") and a total of 26 contacts on HW version 02 and higher (used to be 22 on HW version 01). Potential counterparts on the motherboard are e.g. Samtec 1.27mm (0.05") micro strips of the FTS series (e.g. FTS-113-02-L-D).

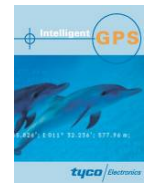

## 5 Pin-out Information

### 5.1 Layout A1029-A

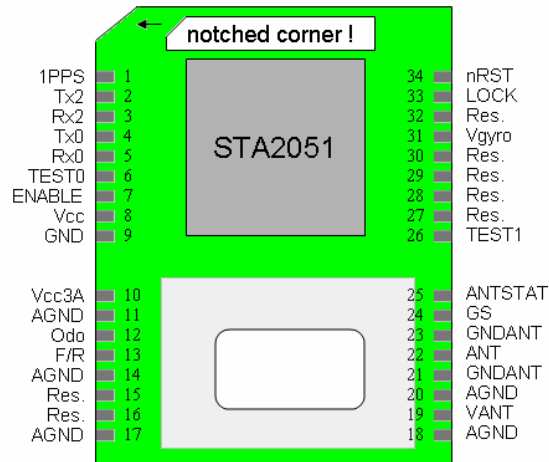



Figure 10: Pin-out information A1029-A (top view)

## 5.2 Description A1029-A Signals

These tables describe the functionality of the pins and their associated symbols. Signals required for Dead Reckoning (when according firmware is enabled) are marked with .

Pin	Symbol	Description
1	1PPS	1PPS (pulse per second) output
2	TX2	Serial output 2
3	RX2	Serial input 2, RTCM input (DGPS)
4	TX0	Serial output 0, NMEA out
5	RX0	Serial input 0, NMEA in
6	TEST0	Reserved for test purposes
7	ENABLE	Enable pin – low power when low
8	Vcc	+3.3V (power supply)
9	GND	Ground (power supply)
10	Vcc3A	Analog voltage supply: For standard GPS functionality connect to Vcc. For DR < +3.3V (see below).
11	AGND	Analog ground For standard GPS functionality leave open. For DR connect to according analog GND.
12	Odo	Odometer input (required for DR, otherwise leave open)
13	F/R	Reverse signal input (required for DR, otherwise leave open)
14	AGND	Analog ground - see above
15	Res.	Reserved – do not connect
16	Res.	Reserved – do not connect
17	AGND	Analog ground - see above

Table 5: Pin description A1029-A (part 1)

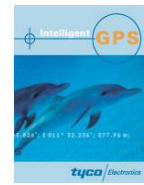

Pin	Symbol	Description
34	nRST	Reset input
33	LOCK	Activated on LOCK (position fix)
32	Res.	Reserved
31	Vgyro	Input pin for gyro output voltage For standard GPS functionality leave open. For DR connect to gyro output (see below).
30	Res.	Reserved
29	Res.	Reserved
28	Res.	Reserved
27	Res.	Reserved
26	TEST1	Reserved for test purposes
25	ANTSTAT	Antenna sensor output
24	GS	Gain Select for LNA – leave open
23	GNDANT	Antenna Ground, do not connect to GROUND, connect to antenna shield (see below)
22	ANT	Antenna signal / Z=50 Ohm
21	GNDANT	Antenna Ground, do not connect to GROUND, connect to antenna shield (see below)
20	AGND	Analog ground - see above
19	VANT	Power supply antenna – provide according voltage.
18	AGND	Analog ground - see above

Table 6: Pin description A1029-A (part 2)

Pins 10 thru 17 used to be all AGND pins on HW version 01, pin 31 used to be a “Res.” pin on HW version 01. For use without Dead Reckoning, no design modification is necessary.

### 5.3 Layout A1029-B

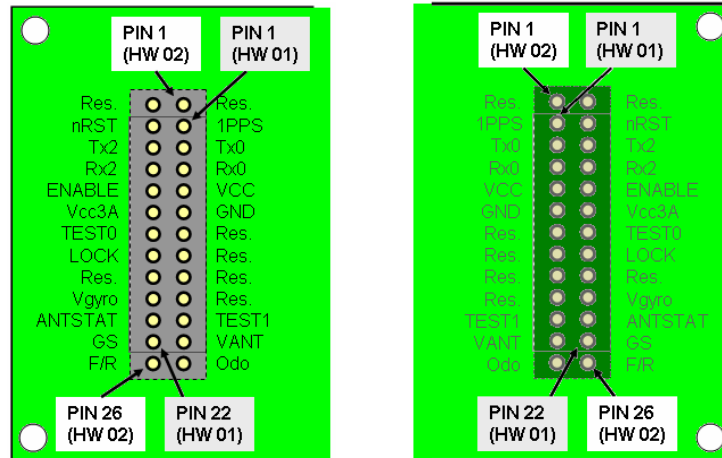
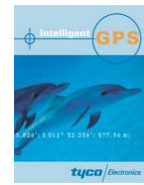



Figure 11: Pin out information A1029-B (bottom and top view)

Bottom view is showing the side of the module that will face the carrier board.



## 5.4 Description A1029-B Signals

These tables describe the functionality of the pins and their associated symbols. Signals required for Dead Reckoning (when according firmware is enabled) are marked with .

Pin (HW 02)	Pin (HW 01)	Symbol	Description
1		Res.	Reserved – do not connect
3	1	1PPS	1PPS (pulse per second) output
5	3	TX0	Serial output 0, NMEA out
7	5	RX0	Serial input 0, NMEA in
9	7	Vcc	+3.3V (power supply)
11	9	GND	Ground (power supply)
13	11	Res.	Reserved – do not connect
15	13	Res.	Reserved – do not connect
17	15	Res.	Reserved – do not connect
19	17	Res.	Reserved – do not connect
21	19	TEST1	Reserved for test purposes
23	21	VANT	Power supply antenna – provide according voltage.
25		Odo	Odometer input (required for DR, otherwise leave open)

Table 7: Pin description A1029-B (part 1 – odd pin row)

Pin (HW 02)	Pin (HW 01)	Symbol	Description
2		Res.	Reserved – do not connect
4	2	nRST	Reset input
6	4	TX2	Serial output 2
8	6	RX2	Serial input 2, RTCM input
10	8	ENABLE	Enable pin – low power when low
12	10	Vcc3A	Analog voltage supply: For standard GPS functionality connect to Vcc. For DR < +3.3V (see below).
14	12	TEST0	Reserved for test purposes
16	14	LOCK	Activated on LOCK (position fix)
18	16	Res.	Reserved – do not connect
20	18	Vgyro	Input pin for gyro output voltage For standard GPS functionality leave open. For DR connect to gyro output (see below).
22	20	ANTSTAT	Antenna sensor output
24	22	GS	Gain Select for LNA – leave open
26		F/R	Reverse signal input (required for DR, otherwise leave open)

Table 8: Pin description A1029-B (part 2 – even pin row)

Pins 12 and 20 on HW version 02 and higher used to be “Res.” pins on HW version 01 (there numbered 10 and 18). For use without Dead Reckoning, no design modification is necessary.

## **5.5 General Comments**

The following comments should be considered for a design with and use of the module:

- Standard configuration of serial port (no DR software):  
Serial 0 (NMEA) 4800 baud, 8 data bits, no parity, 1 stop bit, no flow control  
Serial 2 (DGPS) 4800 baud, 8 data bits, no parity, 1 stop bit, no flow control
- Standard configuration of serial port (with DR software):  
Serial 0 (NMEA) 57600 baud, 8 data bits, no parity, 1 stop bit, no flow control  
Serial 2 (DGPS) 4800 baud, 8 data bits, no parity, 1 stop bit, no flow control
- Antenna (Antenna connected to Antenna Pin – A1029-A only)  
Use ground pins (pin 21, pin 23) close to the antenna input for RF ground.
- Gain Select  
Default setting is “open” (identical to logical low), which results in a high gain (14dB). This setting is recommended.
- nRST  
Do not pull low when in low power mode (ENABLE = LOW)



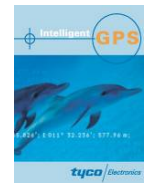

## 6 Dead Reckoning Interface

Dead Reckoning (DR) functionality requires the correct firmware (“2xx”) and the correct hardware set-up on the main board. Two digital signals (odometer and reverse), a gyro and according power supply for the internal ADC are necessary to support this feature. This chapter shall provide all necessary information for designing an according main board. The recommendations here assume the availability of a 5V ( $V_{CC5D}$ ) and 3.3V ( $V_{CC3D}$ ) digital power supply on this main board.

### 6.1 Odometer and Reverse Signals

Both signals are provided by the vehicle. In order to connect the signals in the correct way to the module, they should be optically isolated. The following schematic is an example on how an implementation could look like.

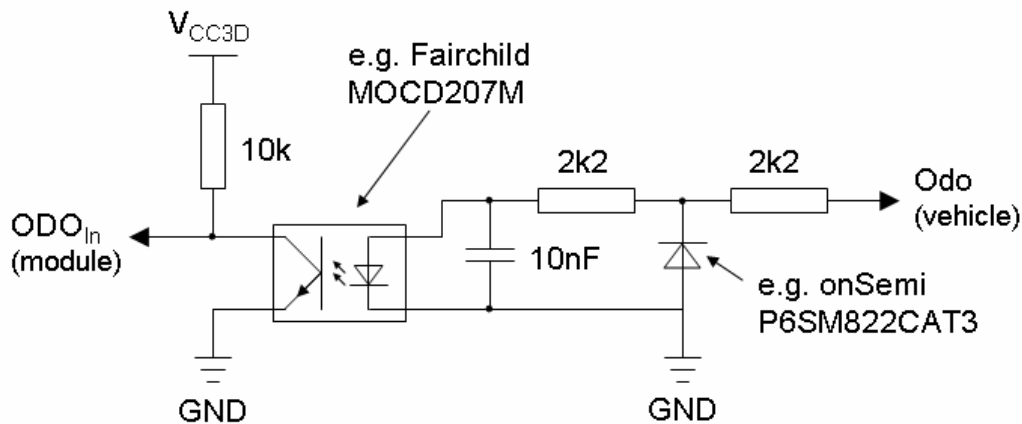

Figure 12: Connecting an odometer signal

The same configuration can be used for the reverse signal.

## 6.2 Gyro and Gyro Signal

The gyro is of utmost importance for the performance of the DR system. The following data shall provide a guideline for selecting the right gyro:

### Basic gyro data

- Supply voltage: 5V (more gyros available, also used in the example) or 3V
- Current draw: < 20mA
- Max. angular velocity:  $\pm 80$  deg./ s
- Output at angular velocity 0: 1.5V (or 2.5V and according divider, as shown in the example)
- Resolution:  $\sim 0.1$  deg/sec
- Scale factor:  $\sim 25\text{mV} / \text{deg} / \text{s}$  (smaller values possible, e.g.  $12.5\text{mV} / \text{deg} / \text{s}$  at supply voltage 3V)

### Important for system performance as well:

- Temperature coefficient of scale factor: max.  $\pm 10\%$  at  $-30^\circ$  to  $+80^\circ\text{C}$
- Linearity:  $\pm 0.5\%$  full scale
- Offset drift: e.g. Melexis MLX90609-N  $\pm 2.5\%$  of Zero Rate Output at  $25^\circ$  (smaller values desirable)
- Response: max. 10Hz
- Noise level; max. 10mVp-p

In the example (also the DR1030A board), the Melexis MLX90609-N is used, a 5V gyro with an output of 2.5V at  $0^\circ/\text{s}$  angular velocity. To allow the complete output range to fit into the input range of the internal ADC, a 2:1 divider is used.

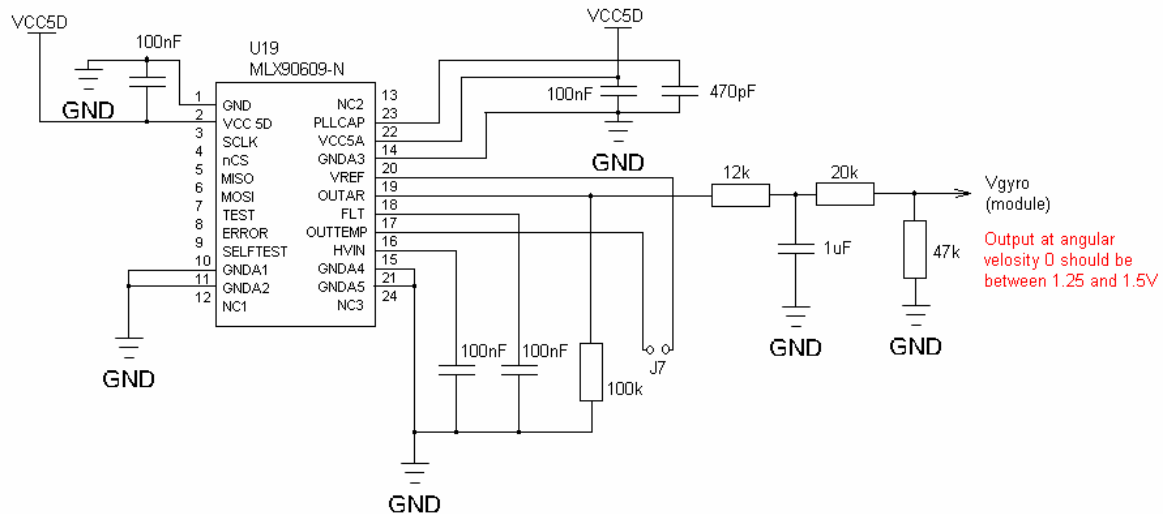

Figure 13: Connecting a gyro and the gyro signal based on the Melexis MLX90609-N (recommended solution)

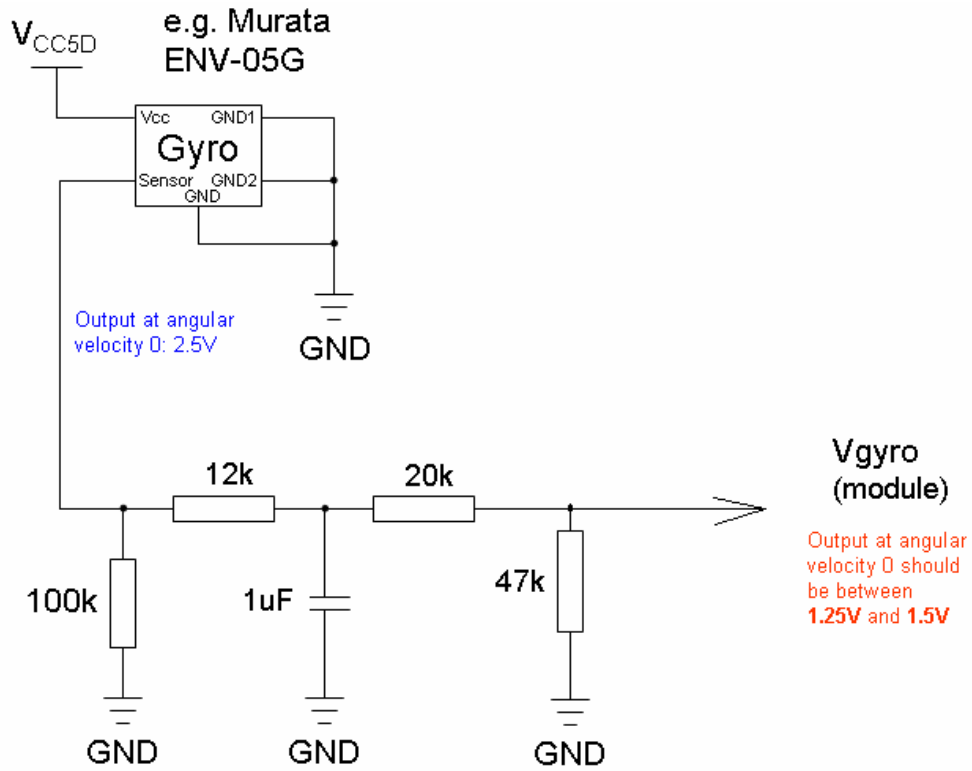
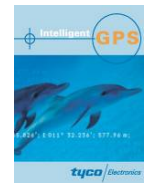

Figure 144: Connecting a gyro and the gyro signal based on the Murata ENV-05G

### 6.3 Power Supply for Internal ADC

The internal ADC requires a separate power supply on pin Vcc3A. The power should be derived from the same source that is used for the gyro. This way, oscillations of the power source affect the gyro and the ADC and therefore minimize the negative effects. It is also recommended that Vcc3A is slightly below the power supplied to module (Vcc).

The following circuit shows an example on how to generate the power for the internal ADC from a 5V source.

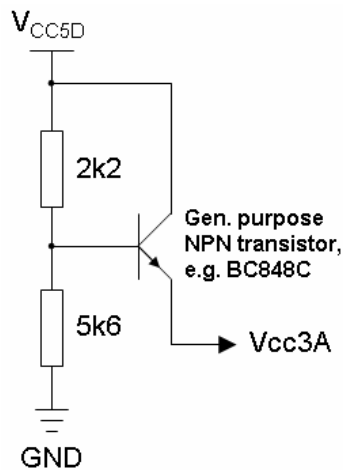

Figure 15: Power supply for internal ADC (Vcc3A)



## 7 Electrical Characteristics

### 7.1 Operating Conditions

Pin		Description	Min	Typical	Max
A	B				
8	9	Vcc	3.0V	3.3V	3.6V
		Current draw (without active Antenna)		50mA	
		Input current in standby mode		30µA	
1	3	1PPS (1 pulse per second), reference GPS time (active and passive antenna)		+120ns +90ns	
19	23	VANT (active antenna supply voltage) Antenna current	Vcc-0.5V		5.2V 50mA
22	na	ANT (antenna pin)		Z <sub>0</sub> =50Ω	
24	24	GS (gain select for LNA), input pin GS high (Low gain – 4dB) GS low (high gain – 14dB)	Vcc-0.6V		Vcc 0.6V
25	22	ANTSTAT (antenna sensor output) @ 1mA current source (antenna current values are typical values) High at antenna current from 9 to 16mA Low at antenna current <9mA or >16mA	Vcc-0.5V 0		Vcc 0.5V
		Output pins VOH VOL	Vcc-0.8V		0.4V
		Input pins VIH VIL	0.7Vcc		0.3Vcc

Table 9: Operating Conditions

### 7.2 Absolute Maximum Ratings

Pin		Description	Min	Max
A	B			
8	9	Vcc	-0.3V	3.6V
		Current Antenna, external power supply		50mA
		Applied voltage to all input pins excluding VCC, VANT	-0.3V	Vcc+0.3V max. 3.6V

Table 10: Absolute maximum ratings

Stresses beyond those listed under “Absolute Maximum Ratings” may cause permanent damage to the device. This is a stress rating only. Functional operation of the device at these or any other conditions beyond those indicated in the operational sections of this specification is not implied. Exposure to absolute maximum rating conditions for extended periods may affect device reliability.

## 8 Mounting

This chapter covers the mounting of the A1029-A. The A1029-B offers a power and I/O connector with a 1.27mm (0.05") low profile, double row socket with a total of 26 contacts on HW version 02 and higher (or 22 contacts on HW version 01). Potential counterparts on the motherboard are Samtec 1.27mm (0.05") micro strips of the FTS series. For fixing the A1029-B on a motherboard appropriate screws and bolts or clips (see also chapter 4.2 Overview A1029-B) are recommended.

### 8.1 Proposed Footprint for Soldering

The following proposal of a footprint for soldering is assuming a stencil thickness of 150µm. ✕ marks the center of the through holes.

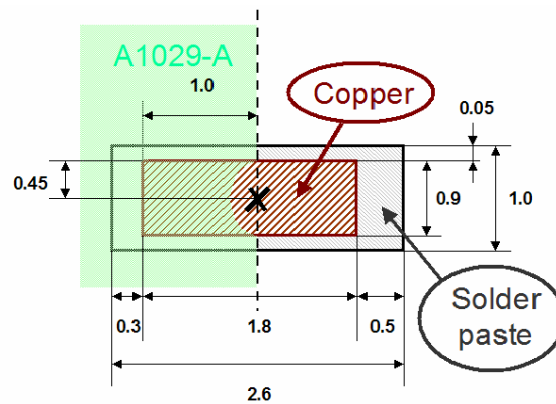
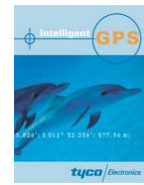

Figure 16: Soldering footprint proposal A1029-A

The final footprint has to be evaluated and qualified by the manufacturer according to the specific processes.



## 8.2 Recommended Profile for Reflow Soldering

Typical values for reflow soldering of the module in convection or IR/convection ovens are as follows:

Peak temperature	235°C
Peak temperature (RoHS compliant process HW version 03 and higher)	245°C
Average ramp up rate to Peak (183°C to Peak)	3°C / second max.
Preheat temperature 125 (±25°C)	120 seconds max.
Temperature maintained above 183°C	60 ... 150 seconds
Time within 5°C of actual peak temperature	10 ... 20 seconds
Ramp Down rate	6°C / second max.
Time 25°C to peak temperature	6 minutes max.

Table 11: Reflow soldering profile A1029-A

As results of soldering may vary among different soldering systems and types of solder and depend on additional factors like density and types of components on board, the values above should be considered as a starting point for further optimization.

## 9 Use of Antenna

### 9.1 Connection of RF Signal

This chapter affects the GPS receiver module A1029-A only.

The ANT pin is used to connect the receiver with the GPS antenna. The design of the antenna connection has to be done strictly according to RF design rules. A 50Ω PCB strip line is required. The following drawings shall explain the guidelines. A major rule is to keep the strip line as short as possible. Additionally, antenna ground (GNDANT) should be routed to the ground plane of the PCB (the ground plane is on a lower PCB layer) by vias as demonstrated in the drawing.

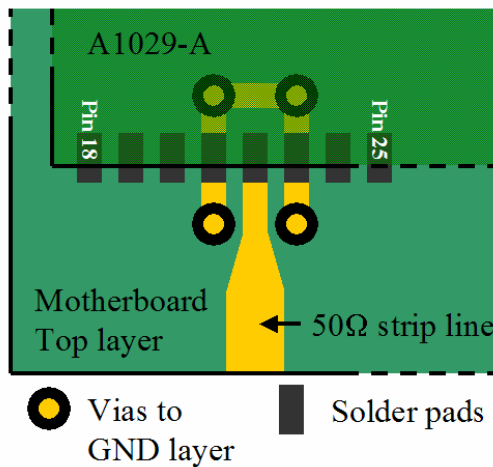

Figure 17: Antenna connector strip line A1029-A

In order to gain the impedance of 50Ω, the width of the strip line needs to be calculated. It depends on the thickness or height of the PCB layer (both parameters are shown in following drawing). For our calculation, we assume that the PCB material is FR4.

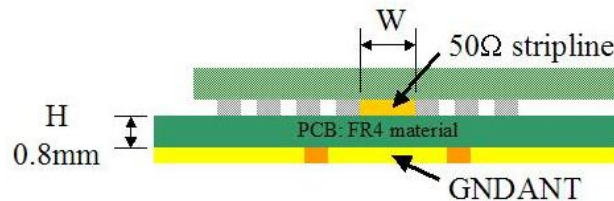

Figure 18: Strip line parameters A1029-A

In this case, the width should be about 1.8 times the height of the PCB:

$$W = 1.8 \times H$$

In our example, we would get a width of  $W = 1.8 \times 0.8\text{mm} = 1.44\text{mm}$ .



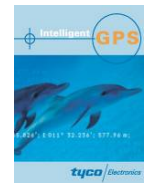

## 9.2 Active Antenna

General GPS active antenna specification:

Limitations:

- Supply voltage according to voltage fed into VANT pin (5V max.)
- Supply current 50mA (max.)

Recommendations:

- Gain  $\geq 20$ dB
- Noise figure  $\leq 1.5$ dB

The recommendations apply to the majority of active antennas that can be found in the market. Anyhow, the quality of the GPS antenna chosen is of paramount importance for the overall sensitivity of the GPS system.

The system design needs to reflect the supply voltage of the antenna. If the supply voltage is equal to  $V_{cc}$ ,  $V_{cc}$  can be connected to VANT. If the antenna requires a different supply voltage, the antenna bias can be provided through the VANT pin.

## 9.3 Passive Antenna

NOTE: Different passive antenna set-ups have been tested with positive results on the performance of the A1029 modules. Anyhow, it is the responsibility of the system integrator to qualify the final configuration.

Please consider that it is crucial to keep the connection from the antenna to the ANT pin as short as possible. Each bit of attenuation between the passive antenna and the ANT pin will degrade GPS performance.

Recommendations:

- Antenna gain:  $>2$ dB<sub>i</sub>
- Antenna gain:  $< 2$ dB<sub>i</sub> / LNA close to the antenna recommended!

Please make sure that the antenna is properly tuned to its dielectric environment.

## 10 Quality and Reliability

### 10.1 Environmental Conditions

Operating temperature	- 40 ... + 85°C
Operating humidity	Max. 85% r. H., non-condensing, at 85°C
MSL JEDEC (Moisture Sensitivity Level)	3
Storage	6 months in original package.

Table 12: Environmental conditions

### 10.2 Product Qualification

Prior to product qualification the GPS receiver is preconditioned according to EIA/JEDEC standard JESD22-A113-B / Level 3.

Basic qualification tests:

- Reflow simulation on test PCB (A1029-A only)
- Temperature Cycling –40°C ... +85°C
- Temperature Humidity Bias 85°C / 85% RH
- High / Low Temperature Operating –40° / +85°C
- High Temperature Operating Life +85°C
- Vibration Variable Frequency
- Mechanical Shock

Please contact Tyco Electronics for detailed information.

### 10.3 Production Test

Each module is electrically tested prior to packing and shipping to ensure state of the art GPS receiver performance and accuracy.

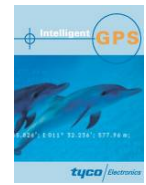

## 11 Applications and Hints

### 11.1 Minimum Configuration

Please refer to chapter 3.1 Minimum Configuration for details. In addition, for optimized start-up behavior it is strongly recommended to add a battery back-up circuit (see chapter 3.4)!

### 11.2 Antenna Sensor Pin (ANTSTAT)

The Antenna Sensor pin is an output pin. It provides correct status information for an active GPS antenna with current consumption in the defined range! For an active antenna with a current consumption outside this range, an external circuit could detect the connection or a disconnection or a short circuit.

- Logic low when:  $I_{ant} < 9\text{mA}$
- Logic high when:  $9\text{mA} > I_{ant} < 16\text{mA}$
- Logic low when:  $I_{ant} > 16\text{mA}$

The threshold values are typical values. Values in an application can defer towards a wider range.

$I_{ant}$  = DC current of GPS antenna (DC current through sensing resistor on GPS module)

The Antenna Sensor pin can detect when an active antenna is connected. It can also detect when the antenna is short-circuited or disconnected for some reason.

Please consider that the Antenna Sensor can provide no useful output when the GPS antenna is fed externally, i.e. the VANT pin is not used (the sensing resistor on the GPS module can not sense any DC current).

### 11.3 Gain select pin (GS)

The LNA Gain Select pin is an input pin.

- Pin at GND (low) or open: LNA Gain 14dB (default)
- Pin at Vcc (high): LNA Gain 4dB

It is recommended to leave the pin unconnected. This allows for amplification of weaker signals and a firmware implementation of an automatic gain control (AGC) function.

### **11.4 VANT pin (antenna voltage input pin)**

The VANT pin is an input pin.

The supply voltage for an active GPS antenna has to be fed into the Vant pin. The easiest way to do that is to connect Vcc to VANT. The maximum current is 50mA. Therefore, when connected to Vcc a current limiter should be used.

### **11.5 LOCK pin (position fix pin)**

The LOCK pin is an output pin.

When there is no valid position fix, the signal on the pin will be a continuous logic low. During a valid position fix phase, the output signal will be a continuous logic high.

### **11.6 ENABLE pin (low-power mode)**

The ENABLE pin is an input pin.

For enabling normal operation of the module, the pin has to be on HIGH level (e.g. connected to Vcc). When the ENABLE pin is pulled down to GND, the module will go to a low power mode where only the RTC will be supported (if a power source is still connected to Vcc). I.e. date and time will be valid after wake-up. The current draw will fall from typically 50mA to typically 30 $\mu$ A. Do not pull down low nRST at the same time! This is not necessary and will result in additional current draw!

### **11.7 1PPS pin (1 pulse per second pin)**

The 1PPS pin is an output pin.

In addition to precise positioning, GPS also allows for accurate timing due to the synchronized atomic clocks in the GPS satellites. While the current date and time is transmitted in NMEA sentences, an exact and accurate timing signal is provided via the 1PPS pin of the A1029 modules.

The 1PPS signal is valid only, whenever the GPS modules provide a valid position fix. Therefore it is recommended to monitor the LOCK signal in parallel (or logically AND the 1PPS and LOCK signals).

The rising edge of the signal is synchronized to GPS time and therefore also to UTC. The 1PPS signal is characterized (a) by the delay “d” between the start of a GPS second and the rising edge of the 1PPS and (b) by standard deviation of this delay providing a measure for the stability or jitter of this signal. Additionally, the duration “l” of the signal is outlined.

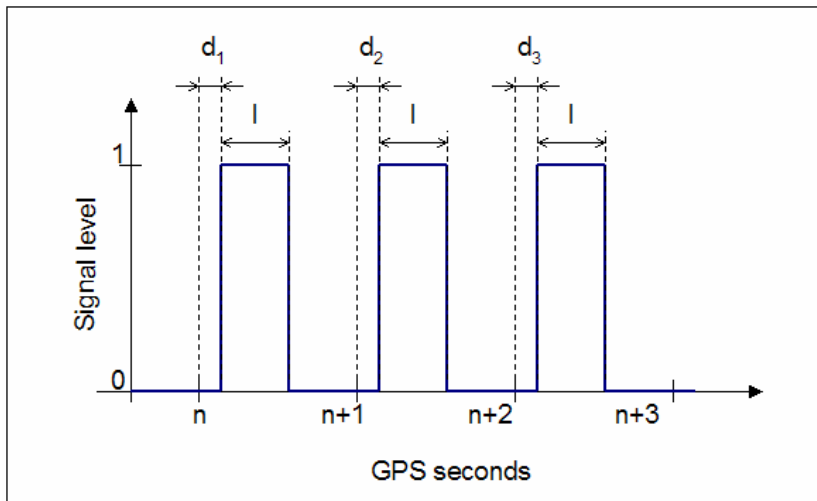

Figure 19: 1PPS signal description

Signal delay $d$ (typical)	130ns
Standard deviation $\sigma_d$ (typical)	20ns
Signal duration $l$ (typical)	500ms

Table 13: 1PPS signal characterization with active antenna with filter at 22°C

Signal delay $d$ (typical)	90ns
Standard deviation $\sigma_d$ (typical)	20ns
Signal duration $l$ (typical)	500ms

Table 14: 1PPS signal characterization with passive antenna at 22°C

The standard deviation is a probability measure for the occurrence of value within a certain range. 68.3% of all new values will be within  $1\sigma$  of the expected value, 95.5% within  $2\sigma$ .

## 11.8 Reset Signal

The nRST pin is an input pin.

The nRST pin can be used to generate a reset on the A1029 modules. Resetting the module will result in a restart of the complete firmware including the boot loader. All information stored in flash memory will still be valid. The RTC will keep on running. The same result can be achieved using the ENABLE pin. Therefore connecting nRST is not necessary.

In case of low power mode (ENABLE pin low) DO NOT pull nRST to low. This will result in additional current draw.

## 12 Application Firmware

Tyco Electronics provides standard GPS firmware that covers the basic functions of a GPS module (e.g. NMEA sentences) and Dead Reckoning firmware that includes Dead Reckoning functionality. Please refer to the GPS Receiver Firmware manuals.

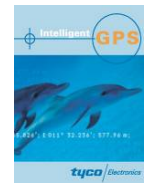

## 13 Demonstration Kits

### 13.1 USB Kit A1029-A

For demonstration and easy evaluation of GPS performance Tyco Electronics offers a Demonstration Kit (including one GPS A1029-A module). It contains a USB interface with according drivers to connect easily to a PC. The USB interface is an extension of the serial port 0, therefore sending NMEA sentences and accepting commands. At the same time it provides power to the module. Accompanied by an antenna it offers a ready-to-go set. For further information please contact Tyco Electronics.

### 13.2 Evaluation Kit A1029-A

For the development of new software and applications an Evaluation Kit is available. It shows various connectors for easy access to the JTAG port, to the general purpose I/Os, and the serial ports. It can be powered by battery or externally. For further information please contact Tyco Electronics.

### 13.3 Demonstration Kit A1029-B

For demonstration and easy evaluation of GPS performance Tyco Electronics offers a Demonstration Kit (including one GPS A1029-B module). It shows two serial interfaces (NMEA and RTCM). The Demonstration Kit can be powered by an external 5 to 12V source. Accompanied by an antenna and serial cable it offers a ready-to-go set. For further information please contact Tyco Electronics.

## 14 Related Information

### 14.1 Contact

This manual was created with due diligence. We hope that it will be helpful to the user to get the most out of the GPS module.

Anyway, inputs about errors or mistakable verbalizations and comments or proposals to TYCO Electronics, Power Systems in Munich, Germany, for further improvements are highly appreciated.

Hans Wiedemann  
Product Marketing Manager  
Positioning Products  
Tel.: +49 89 6089 838  
Fax: +49 89 6089 835

Tyco Electronics Corporation  
Power Systems  
Finsinger Feld 1  
85521 Ottobrunn, Germany

Email to [gps@tycoelectronics.com](mailto:gps@tycoelectronics.com).

Please visit our website at [www.tycoelectronics.com/gps](http://www.tycoelectronics.com/gps).

### 14.2 Related Documents

- Manual: T.E. GPS Firmware A1029 (TYCO)
- Manual: T.E. GPS Firmware DR A1029 (TYCO)
- Manual: T.E. GPS DemoKit USB1029-A (TYCO)
- Manual: T.E. GPS EvaluationKit EVA1029-A (TYCO)
- Manual: T.E. GPS DemoKit DKS1030-A (TYCO)
- Manual: T.E. GPS Bootloader A1029 (TYCO)



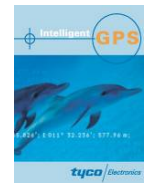

This page was intentionally left blank.



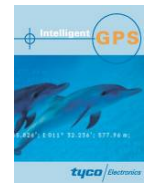

## 15 List of Tables

Table 1: A1029 characteristics.....	8
Table 2 and 3: A1029-A and A1029-B dimensions and weight.....	8
Table 4: Additional equipment .....	12
Table 5: Pin description A1029-A (part 1).....	20
Table 6: Pin description A1029-A (part 2).....	21
Table 7: Pin description A1029-B (part 1 – odd pin row).....	23
Table 8: Pin description A1029-B (part 2 – even pin row).....	23
Table 9: Operating Conditions .....	29
Table 10: Absolute maximum ratings .....	29
Table 11: Reflow soldering profile A1029-A .....	31
Table 12: Environmental conditions.....	34
Table 13: 1PPS signal characterization with active antenna with filter at 22°C .....	37
Table 14: 1PPS signal characterization with passive antenna at 22°C.....	37

## 16 List of Figures

Figure 1: A1029 label.....	8
Figure 2: A1029-A tape specifications (1).....	10
Figure 3: A1029-A tape specifications (2).....	11
Figure 4: A1029-B tray specification.....	11
Figure 5: Recommended minimum configuration A1029-A.....	13
Figure 6: Mechanical outline overview A1029-A .....	15
Figure 7: Mechanical outline component side A1029-A .....	16
Figure 8: Mechanical outline solder side A1029-A .....	17
Figure 9: Mechanical outline overview A1029-B .....	18
Figure 10: Pin-out information A1029-A (top view).....	19
Figure 11: Pin out information A1029-B (bottom and top view).....	22
Figure 12: Connecting an odometer signal.....	25
Figure 13: Connecting a gyro and the gyro signal based on the.....	26
Figure 144: Connecting a gyro and the gyro signal based on the.....	27
Figure 15: Power supply for internal ADC (Vcc3A) .....	28
Figure 16: Soldering footprint proposal A1029-A .....	30
Figure 17: Antenna connector strip line A1029-A.....	32
Figure 18: Strip line parameters A1029-A .....	32
Figure 19: 1PPS signal description.....	37