

## 7.2 USB to RS485 Converter

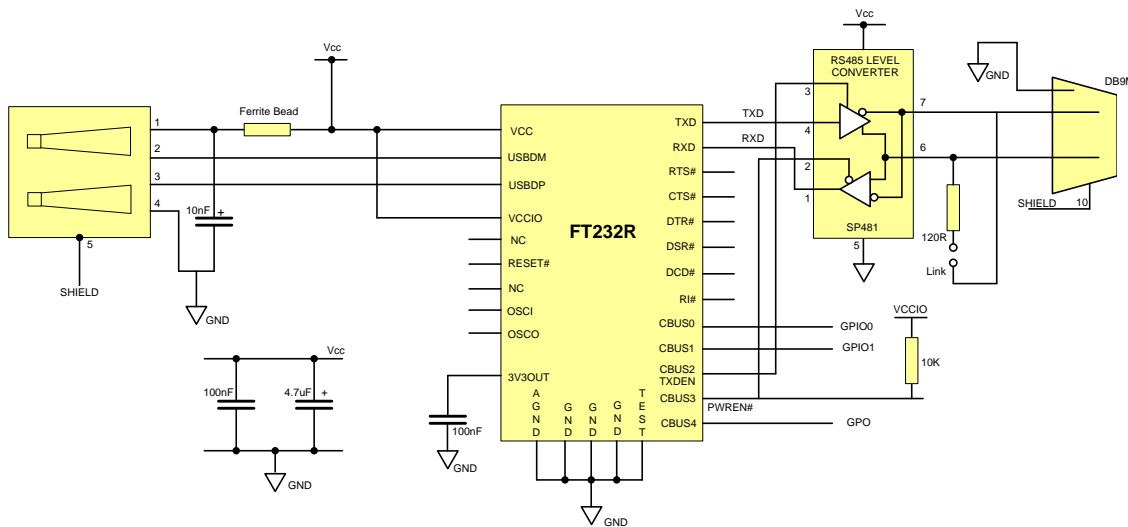

**Figure 7.2 Application Example Showing USB to RS485 Converter**

An example of using the FT232R as a USB to RS485 converter is shown in Figure 7.2. In this application, a TTL to RS485 level converter IC is used on the serial UART interface of the FT232R to convert the TTL levels of the FT232R to RS485 levels.

This example uses the Sipex SP481 device. Equivalent devices are available from Maxim and Analogue Devices. The SP481 is a RS485 device in a compact 8 pin SOP package. It has separate enables on both the transmitter and receiver. With RS485, the transmitter is only enabled when a character is being transmitted from the UART. The TXDEN signal CBUS pin option on the FT232R is provided for exactly this purpose and so the transmitter enable is wired to CBUS2 which has been configured as TXDEN. Similarly, CBUS3 has been configured as PWREN#. This signal is used to control the SP481's receiver enable. The receiver enable is active low, so it is wired to the PWREN# pin to disable the receiver when in USB suspend mode. CBUS2 = TXDEN and CBUS3 = PWREN# are the default device configurations of the FT232R pins.

RS485 is a multi-drop network; so many devices can communicate with each other over a two wire cable interface. The RS485 cable requires to be terminated at each end of the cable. A link (which provides the 120Ω termination) allows the cable to be terminated if the SP481 is physically positioned at either end of the cable.

In this example the data transmitted by the FT232R is also present on the receive path of the SP481. This is a common feature of RS485 and requires the application software to remove the transmitted data from the received data stream. With the FT232R it is possible to do this entirely in hardware by modifying the example shown in Figure 7.2 by logically OR'ing the FT232R TXDEN and the SP481 receiver output and connecting the output of the OR gate to the RXD of the FT232R.

Note that the TXDEN is activated 1 bit period before the start bit. TXDEN is deactivated at the same time as the stop bit. This is not configurable.