



AN ISOLATED GATE DRIVE FOR POWER MOSFETs AND IGBTs

by J.M. Bourgeois

ABSTRACT

Power MOSFET and IGBT gate drives often face isolation and high voltage constraints. The gate drive described in this paper uses a Printed Circuit Board based transformer in combination with the memory effect of the Power MOSFET input capacitance to achieve the isolation.

This transformer is a bi-directional link between the ground-referenced control IC and the floating gate drive. It transfers drive energy and signal information to the gate drive, provides full duty cycle range and perfect dV/dt immunity, and imposes virtually no voltage constraint. No floating auxiliary supply is required.

If the short circuit protection is triggered, an alarm signal is transmitted back to the primary through the same transformer. This circuit is perfectly suited to driving floating and/or isolated switches in motor drives, uninterruptible power supplies and AC switches.

1. INTRODUCTION

Isolated power switches are often used in motor drives, uninterruptible power supplies and AC switches. Isolation is usually a requirement of safety norms and operating conditions when the switch voltage floats with respect to ground.

This paper highlights a specific characteristic of the Power MOSFET which is often neglected: the use of the gate input capacitance as an ON state memory. It proposes an innovative isolated gate drive using a pulse transformer constructed using copper PCB tracks, combined with the memory effect of the Power MOSFET.

2. PRINCIPLES OF OPERATION

The circuit operates using the Power MOSFET input capacitance to memorize the ON-state, a second auxiliary capacitor to memorize the OFF-state, and PCB tracks to form the windings of the transformer.

APPLICATION NOTE

The transformer is driven by pulses in bi-directional mode; when a voltage pulse is applied across the primary, energy is transmitted to the secondary and the state of the Power MOSFET is defined (ON or OFF). After the primary pulse, in the steady state, an alarm signal can be transmitted from the secondary to the primary if a short circuit is detected.

3. IMPLEMENTATION

The circuit shown in figure 1 implements these principles. The Power MOSFET or IGBT input capacitance memorizes its ON-state. The capacitor C7 memorizes the OFF-state and maintains a low impedance between the gate and source terminals during the OFF-state via T7. Short circuit

Figure 1: Circuit implementing isolated gate drive

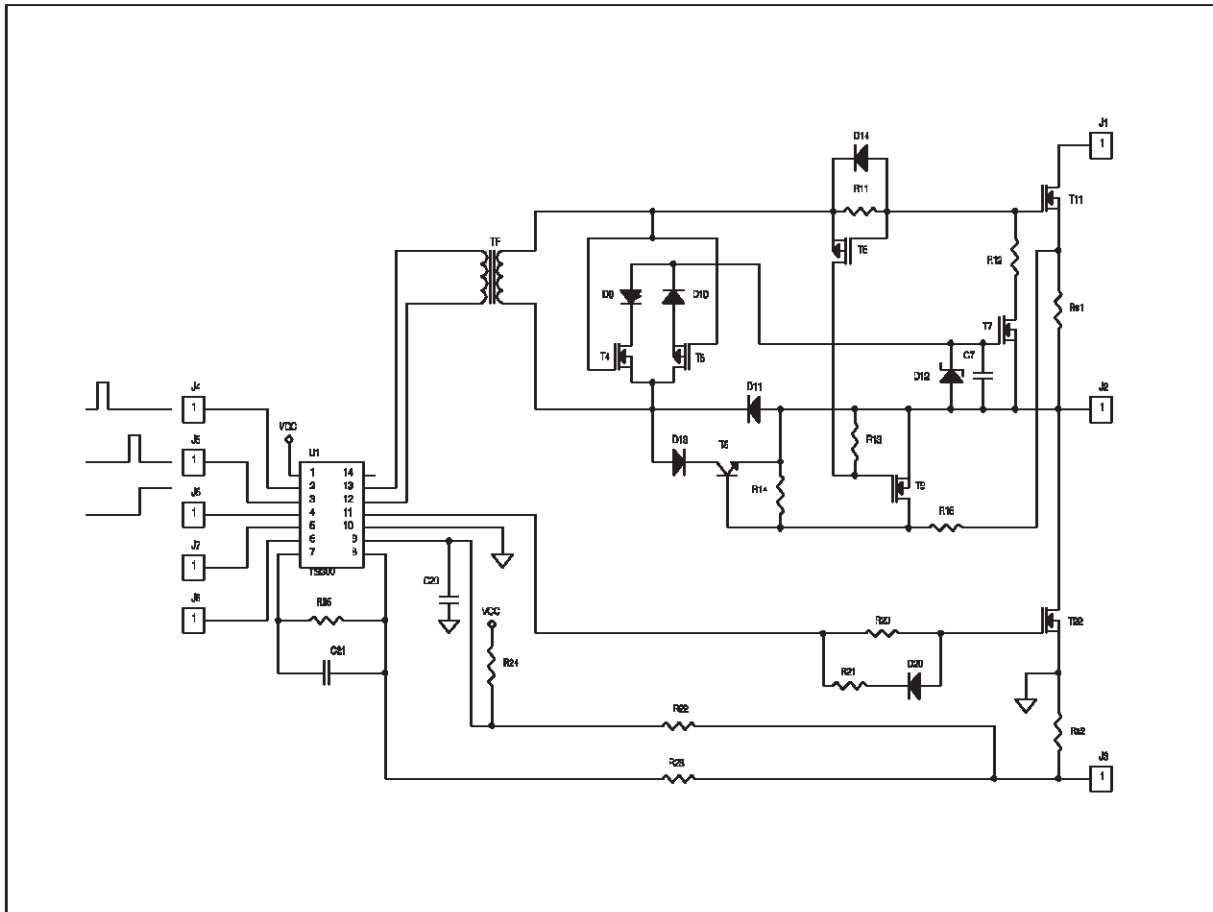

protection with masking of the free wheeling diode recovery current is implemented with T6, T8 and T9. If the circuit is to be operated under 1kHz, provision must be made for

refresh of the memory capacitances. The circuit shown in figure 5 is a simplified version of that shown in figure 1.

4. FUNCTIONAL DESCRIPTION

Figure 2 shows a block diagram of the circuit. It consists of a TD300 pulse transformer driver, a PCB based transformer and an isolated secondary circuit.

4.1 Primary circuit

The TD300 is a three channel MOSFET driver with pulse transformer driving capability. It has been optimized for both capacitive load drive and pulse transformer demagnetization.

Figure 2: Circuit block diagram

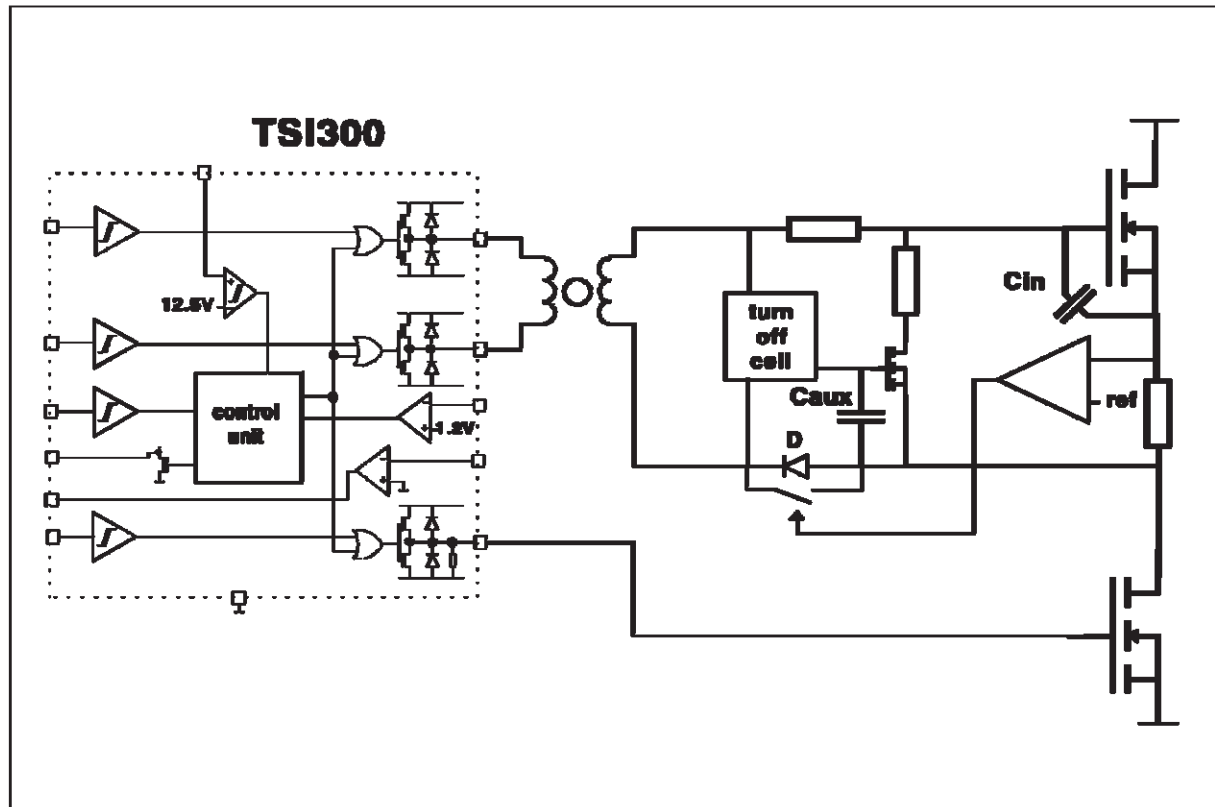

It can therefore directly drive a low side switch and, through a pulse transformer, an high side switch. Its low buffer $R_{DS(ON)}$ can conduct a demagnetizing current of 100mA with no significant voltage drop. The transformer inductance can therefore be kept low, and the transformer windings can be implemented with few turns laid on a Printed Circuit Board.

The TD300 integrates three additional circuits enabling protection and control functions: an undervoltage lockout, an operational amplifier and a comparator.

4.2 Pulse transformer

The pulse width required to fully charge the gate capacitance is typically around 1 μ sec. Supposing that double pulses can occur during the operation, the maximum Volt.second product is 30V/ μ sec. With a magnetizing current of 100mA, the primary transformer inductance required is:

$$L = V \cdot (di/dt)^{-1} = 300\mu\text{H}$$

This low value of inductance allows the primary winding to be limited to 10 turns using a realistic section of ferrite.

APPLICATION NOTE

Figure 3 shows an implementation using PCB tracks to form the inductor. Track widths are 12 mils at the primary and 10 mils at the secondary. The inter-line distance is 4 mils in both cases (mask definition).

Experimental tests showed that the magnetizing current reaches 100mA after 2 μ sec using a standard A4-U-1606A made of high permeability material ($\mu_i = 6000$ - standard THOMSON Passive Components).

Figure 3: PCB layout: a) Upper side
b) Lower side

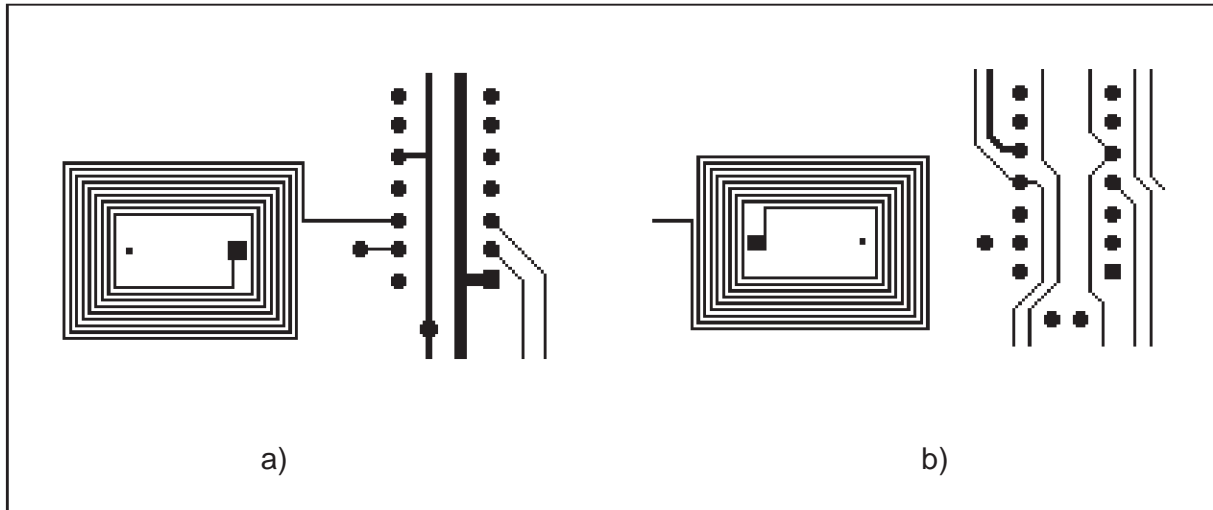

However the magnetic path of this U core is too long for through-hole applications. Using a bus bar core shape with the same section but with shorter legs to fit the PCB, the magnetizing current should fall to 60mA. It is then possible to increase the pulse time or to decrease the core section to obtain a magnetizing current of 100mA.

4.3 Secondary circuit

Many different secondary circuit topologies can be used, depending on application performance and cost. The cheapest solution uses one zener diode and one resistor, but the digital control is more complex, and it has no floating short circuit protection (see reference 6).

For more sophisticated applications, figure 4 shows a step by step analysis of the secondary circuit shown in figure 1.

Turn-ON pulse: figure 4a shows the charge current I_c of the MOSFET input capacitor when a positive pulse is applied across the

pulse transformer primary. When the primary pulse ends, the transformer secondary voltage is approximately zero, and the diode D prevents C_{in} from being discharged.

In figure 4b, the MOSFET keeps its gate charge after the pulse and remains in the conducting state. The ON-state is memorized in the input capacitor C_{in} .

Turn-OFF pulse: Figure 4c shows the input capacitor discharge current I_d when a negative pulse is applied across the pulse transformer primary. Discharge occurs when an additional circuit transfers the secondary voltage to the auxiliary capacitor C_{aux} , making T_{aux} conduct. When the pulse ends, the OFF-state is memorized in the auxiliary capacitor. A low impedance is then maintained across the power switch, avoiding unwanted turn-on (see figure 4d).

Short circuit protection: A short circuit can be detected by means of a shunt or current sense. Then, the diode D is shorted,

Figure 4: Details of circuit operation

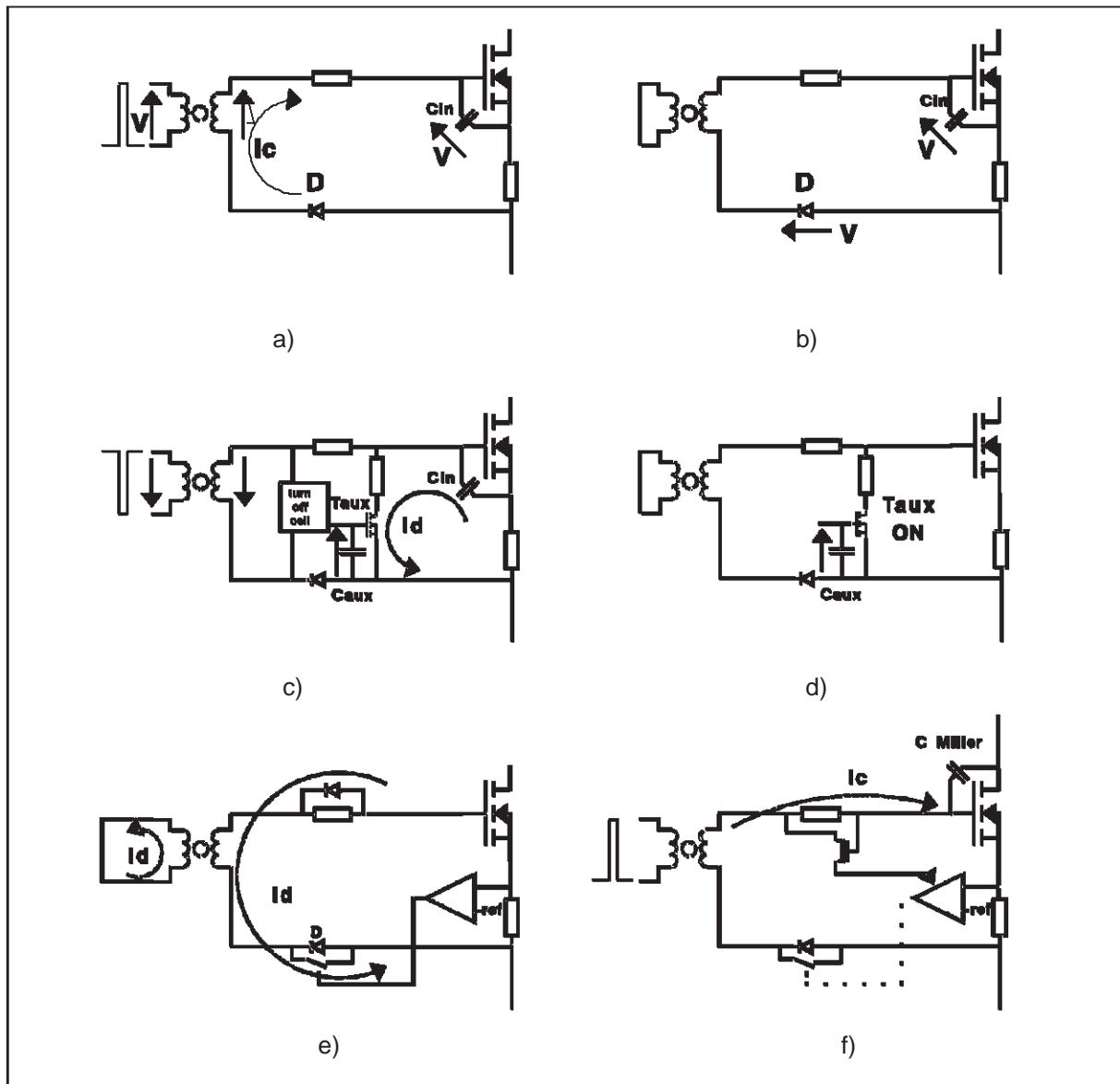

allowing the power input capacitor to discharge through the pulse transformer just after the turn-on pulse. This produces a negative current pulse in the transformer secondary, enabling the short circuit to be detected via the primary winding. Indeed, this discharge current inverts the demagnetizing current temporarily, inverting the buffer output voltage (see current I_d , figure 4e). The short circuit conduction time is approximately the turn-on pulse time.

Diode recovery current: Generally, inverter power switches face a diode recovery current at turn on. This creates a brief over-current in the switch that requires masking from the short circuit detection during the recovery time.

Due to the Miller effect, the current I_c lasts for as long as the collector/drain voltage falls. Inhibiting the short circuit detection by means of I_c masks all the diode recovery current (see figure 4f).

5. MAIN FEATURES OF THE CIRCUIT

5.1 No floating auxiliary supply

The power MOSFET switches are supplied by pulses from the transformer. No floating auxiliary supply is required.

5.2 Large operating frequency range

This driver can operate at up to several tens of kiloHertz because the transformer delivers very short pulses, typically 500nsec or 1µsec. If DC or very low frequency operation is required, circuits to perform an automatic refresh of memory capacitors must be implemented; the primary circuit should then drive the transformer with a burst of positive or negative pulses. (see reference 6).

5.3 Large duty cycle

Again because of the length of the transformer pulses, the possible range of duty cycles is large: the minimum ON or OFF time is about 500nsec, allowing the duty cycle to range from 1% to 99% at 20kHz. There is no maximum ON or OFF time.

5.4 Low energy and cheap transformer

The energy transferred to the secondary by the pulse transformer is (on average per cycle) about four times the energy stored in the gate capacitor (average current of about 2mA at 10kHz for 50nF). The transformer magnetizing energy must be added two times per cycle (average current of about 2mA at 10kHz for 300µH), so global driver energy consumption is very small.

The construction of the transformer can be automated using PCB based windings.

5.5 Good ground to gate drive isolation and perfect dV/dt immunity

Because the pulse transformer provides the isolation, creepage distance and clearance are easily adjusted to suit the application requirements.

The primary-secondary electrostatic coupling effects are negligible, and immunity to fast voltage variations (dV/dt) is perfect.

Figure 5: Simplified circuit

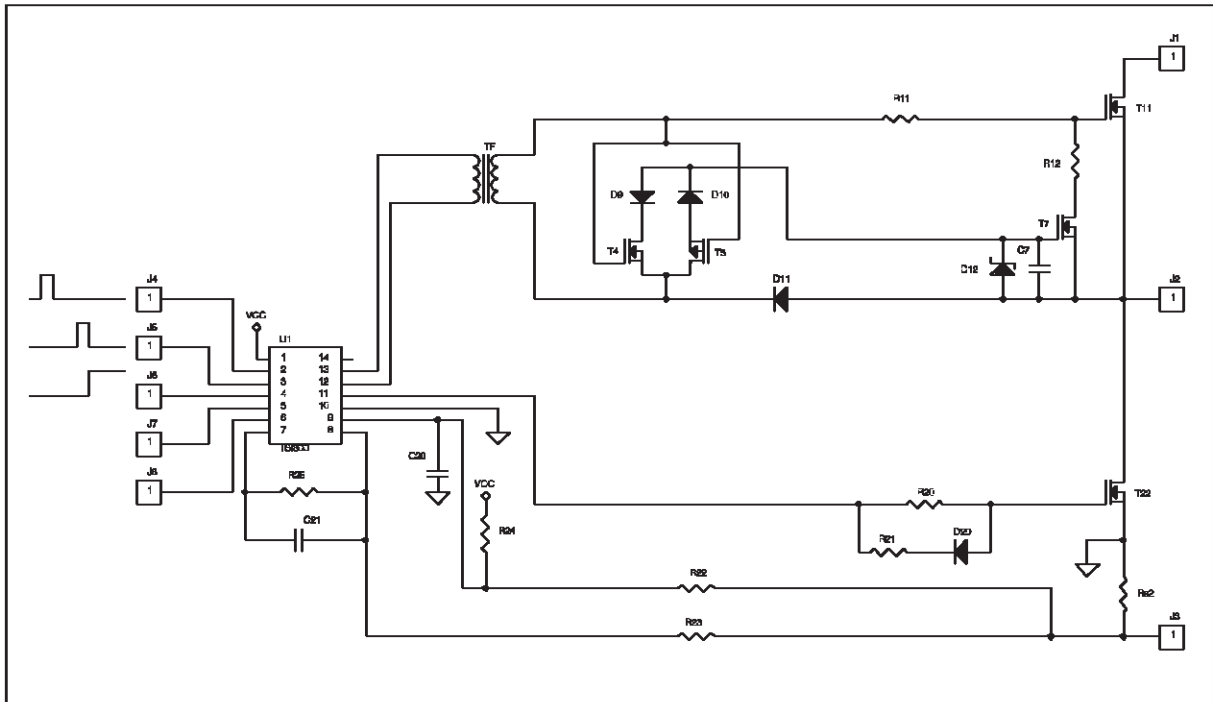

5.6 Low gate drive output impedance during OFF-state

During its OFF-state, a low impedance is maintained across the gate-source terminals of the Power MOSFET, avoiding unwanted turn-on should any external dV/dt be applied to the MOSFET.

5.7 Short circuit protection

The secondary circuit has an automatic short-circuit protection. This protection is inhibited during turn-on pulses in order to mask diode recovery current.

5.8 Alarm signal

When the short-circuit protection is operating, the Power MOSFET input capacitor is discharged through the pulse transformer, causing an alarm signal to be transmitted in the reverse direction from the secondary to the primary of the pulse transformer.

6. CONCLUSION

This Power MOSFET drive is perfectly suited to drive floating and/or isolated switches. Its operating mode permits a large range of duty cycles, requiring no floating auxiliary supply, and has perfect dV/dt immunity. The short circuit protection provides an alarm signal to the grounded circuit control via the pulse transformer.

This circuit operates whatever the line voltage as long as suitably rated power switches are used. Its transformer windings are laid on a double-sided PCB, allowing

automation of the transformer construction process.

Its major fields of application are motor drives, uninterruptible Power supplies and AC switches.

REFERENCES

1. Power Semiconductors for High Frequency AC/DC Converters supplied on 380/440Vac Mains
L.Perier, J.M.Charreton
SGS-THOMSON Microelectronics
Application note AN368
2. Optimized Power Stages for High Frequency 380/440VAC Medium Power Switch Mode Supplies
CK.Patni, L. Perier
SGS-THOMSON Microelectronics
Application note AN369
3. Improved Transistorized High Power Chopper
K. Rischmuller - PCI '83 GENEVA
4. Simplified Switch Mode Base Drive Circuit with L4974 Smart Power I.C.
K. Rischmuller
SGS-THOMSON Microelectronics
Application note AN364
5. Power Transistor Application Manual
SGS-THOMSON Microelectronics
6. Pulse Controlled Inverter
J.M. Bourgeois
SGS-THOMSON Microelectronics
Application note AN522

Information furnished is believed to be accurate and reliable. However, STMicroelectronics assumes no responsibility for the consequences of use of such information nor for any infringement of patents or other rights of third parties which may result from its use. No license is granted by implication or otherwise under any patent or patent rights of STMicroelectronics. Specification mentioned in this publication are subject to change without notice. This publication supersedes and replaces all information previously supplied. STMicroelectronics products are not authorized for use as critical components in life support devices or systems without express written approval of STMicroelectronics.

The ST logo is a trademark of STMicroelectronics

© 1999 STMicroelectronics - Printed in Italy - All Rights Reserved

STMicroelectronics GROUP OF COMPANIES

Australia - Brazil - China - Finland - France - Germany - Hong Kong - India - Italy - Japan - Malaysia - Malta - Morocco - Singapore - Spain - Sweden - Switzerland - United Kingdom - U.S.A.



<http://www.st.com>