

CH1 and CH2 are slots to increase the creepage distance between the primary and secondary transformer pins that may be needed for safety certification (the creepage requirement is voltage dependent)

12.5mm creepage on reference board design

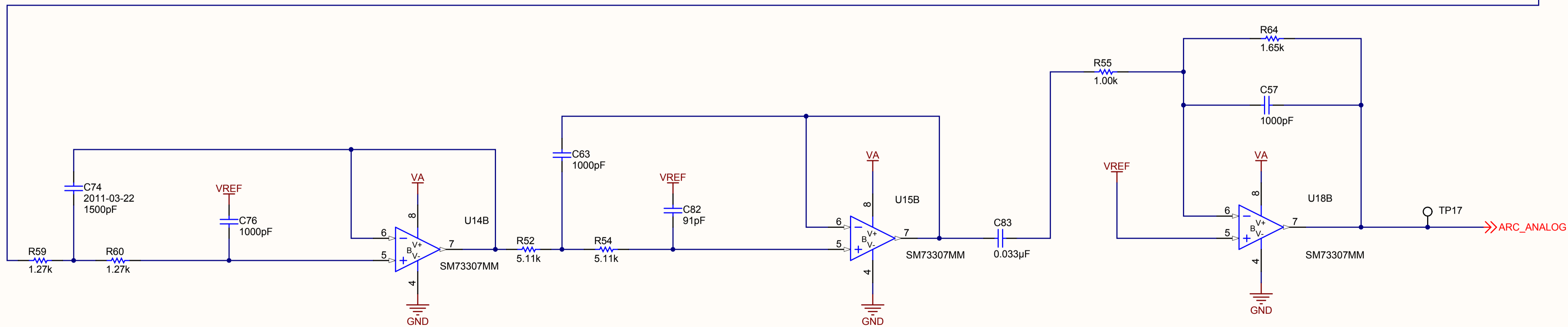

National Semiconductor and/or its licensors do not warrant the accuracy or completeness of this specification or any information contained therein. National and/or its licensors do not warrant that this design will meet the specifications, will be suitable for your application or fit for any particular purpose, or will operate in an implementation. National and/or its licensors do not warrant that the design is production worthy. You should completely validate and test your design implementation to confirm the system functionality for your application.

Designed for: [National Semiconductor](#) Mod. Date: 6/18/2012
 Project: [SM73201 - ARCTest](#)
 Sheet Title: [Arc Detect Analog Front End](#) Sheet: 4 of 7
 Size: B Schematic: [870600620](#) Rev: 005
 Assembly Variant: [\[No Variations\]](#)
 File: [SM73201-ARC QFN-56 Detect AFE.SchDoc](#)
 Contact: <http://www.national.com/support>



<http://www.national.com>

© Copyright, National Semiconductor, 2010

When using the PA3655NL transformer the NOISE signal should be at least 300 mV p-p for reliable operation

+V should be between 8 and 12 Volts (for proper operation of noise circuit)

The C_NOISE signal should be about 100 mV p-p

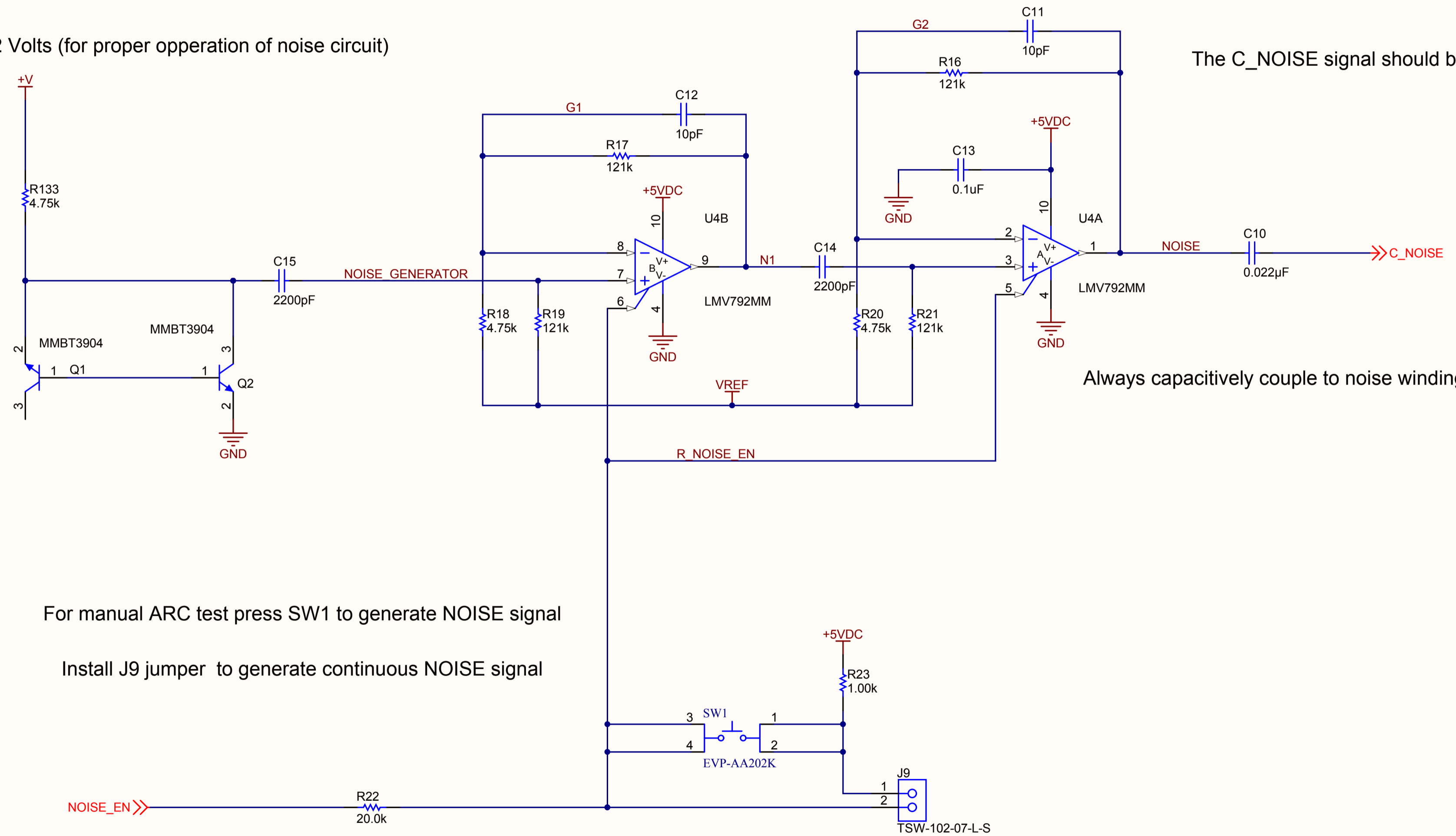

Always capacitively couple to noise winding on transformer

For manual ARC test press SW1 to generate NOISE signal

Install J9 jumper to generate continuous NOISE signal

For CPU ARC test J9 must not be installed then drive NOISE_EN signal (GPIO6) high to generate NOISE signal

National Semiconductor and/or its licensors do not warrant the accuracy or completeness of this specification or any information contained therein. National and/or its licensors do not warrant that this design will meet the specifications, will be suitable for your application or fit for any particular purpose, or will operate in an implementation. National and/or its licensors do not warrant that the design is production worthy. You should completely validate and test your design implementation to confirm the system functionality for your application.

Designed for: National Semiconductor | Mod. Date: 6/18/2012
 Project: SM73201 - ARCTest
 Sheet Title: Arc Detect Filter | Sheet: 7 of 7
 Size: B | Schematic: 870600620 | Rev: 005
 Assembly Variant: [No Variations]
 File: SM73201 - ARC QFN-56 Test.SchDoc
 Contact: <http://www.national.com/support>



<http://www.national.com>

© Copyright, National Semiconductor, 2010