

METCAL MX-500P-11 TECHNICAL DOCUMENTATION

This documentation was carefully reverse engineered from several actual MX-500P units, and although it has been meticulously triple checked, it may contain errors and omissions so use it at your own risk. It is provided solely for the purpose of helping you satisfy your personal curiosity about how a Metcal MX-500P works, and you must never use it for any other purpose, especially not for any commercial or business purpose, and certainly not as an aide to experimenting with or performing work on MX-500P units, as it is inadequate for such unintended use. Reproduction is strictly forbidden.

MECHANICAL DESCRIPTION:

The small plastic cover at the two RF output connectors is held in place by its two plastic hooked clips which descend into the aluminum housing at the top and bottom. Beneath this plastic cover are two hex nuts that bolt the RF connectors to the aluminum housing. The RF connectors are soldered directly into the circuit board. On the rear of the MX-500P are four deeply recessed T15 tamper proof Torx screws which hold the two halves of the aluminum casting together. Loosening the single screw in the upper-middle back of the MX-500P by a few turns releases the internal heat sink which is attached to the circuit board. The internal heat sink couples heat into the MX-500P aluminum case from where it can dissipate into the ambient air. Good thermal coupling between the internal heat sink and the case is aided by a thin coating of white thermal compound. The circuit board inside the MX-500P is fastened down by six internal screws, four of which are rather large because they also hold down the line transformer. The tiny grub screw on the upper right hand side of the MX500 controls the Auto Sleep feature and should not be tightened past the point where it gently activates the switch. Note that it can be dangerous to power up an MX-500P unit that has been taken apart or that has been reassembled by anyone other than a trained Metcal service technician.

DESCRIPTION OF FUNCTION:

The MX-500P Power Unit provides RF energy at 13.560MHz to the Soldering Tip Cartridge, which contains an induction heater consisting of an 18 turn AWG33 wire coil wound around a 0.11" diameter by 0.5" long slug. The slug is composed of a copper core, clad in a thin magnetic alloy having a curie point equal to the desired soldering tip temperature. The magnetic alloy absorbs RF energy from the coil, causing the slug to heat up until the curie temperature is reached. At this point absorption stops and heating ceases, because the RF energy is now reflected back to the power unit by the copper core.

The On/Off switch atop the power unit controls the 18V power supply U8, which runs all the supervisory circuits. When the 18V supply is off, Q6 turns off thereby causing Q7 to turn on and disable the RF generator.

Q5 and Q8 control a small DC bias voltage out to the soldering hand piece, so that U2a can sense an intermittent or disconnected hand piece cable, in which case the yellow LED DS2 will light and U2b will latch Q7 on, thereby disabling the RF generator until the On/Off switch is cycled.

U5a senses small changes in RF generator output power to the soldering hand piece. If no changes are detected for half an hour then sleep mode timer U6 times out causing U7 to latch Q11 on, thereby disabling the RF generator until the On/Off switch is cycled. This functionality can be disabled by backing out the tiny grub screw in the upper right side of the unit.

If thermal switch TS1 detects an over temperature condition inside the power unit then Q9 will turn on and disable the RF generator until the temperature drops back down to normal.

If Forward Power at T3 and C33 exceeds reasonable limits due to a fault in the power unit circuitry, then Q19 will turn on and disable the RF generator until Forward Power returns to acceptable levels.

U5b monitors the supervisory circuits and lights green LED DS1 if everything is OK, in which case Q12 will be on, enabling U4 to power up the RF generator.

U1 provides a 13.560MHz square wave out to class C driver stage Q3, which in turn drives the class C final output stage Q4, providing RF power to the soldering hand piece. Note that Q3 is unusual in that it has an input capacitance of only 55pF and a gate threshold voltage of only 1.6V.

Diodes D8 and D9 sense the RF voltage level coming out of the RF generator, providing negative feedback to switching power supply U4 Q1 Q2, which powers the final RF output stage Q4 of the RF generator.

J1 provides a DC voltage which is proportional to the power being delivered to the hand piece. It can be connected to an analog meter movement or other measuring instrument.

TRIMPOT DESCRIPTIONS:

RV2 adjusts the RF-Output-Power delivered to the hand piece; if this adjustment is incorrect then the voltage at C8 will likely not correspond to the values given elsewhere in this document.

RV1 sets the Forward-Power-Fault safety shutdown circuit trip point; if this adjustment is incorrect then the voltage at C16 will likely not correspond to the values given elsewhere in this document.

RV3 calibrates the signal out to any Meter connected at J4; the signal at J4 is not normally used so it is hard to imagine how this adjustment could have any impact upon the operation of the unit.

Calibration is well beyond the scope of this document and must not be attempted by anyone other than a qualified Metcal service technician.

MEASUREMENTS FROM SOME GOOD WORKING UNITS:

Whenever unit is plugged into the AC line:

Voltage at C2 will measure approximately 26 VDC

Voltage at C6 will measure approximately 53 VDC

Whenever the power switch is on and unit is plugged in:

U8 pin 3 will measure 18 VDC

U7 pin 14 will measure 12 VDC

Whenever a hand piece is connected and the green LED is lit:

U4 pin 4 will measure 1.3 VDC

U4 pin 5 will measure 0.0 VDC

If the green LED is extinguished but the unit is plugged in:

U4 pin 5 will measure 26 VDC

Whenever the hand piece is idling hot in the stand:

Voltage at C8 will measure between 17 and 18 VDC

Voltage at C3 will measure between 14 and 15 VDC

Voltage at C16 will measure approximately minus 1.2 VDC

U1 pin 14 will measure approximately 4.8 VDC

U1 pin 4 will have a 13.56 Mhz waveform approximately 2.8 Vpp

When the soldering hand piece is heating up from a cold start:

Voltage at C8 may temporarily rise as high as 21 VDC

Voltage at C16 may temporarily rise as high as minus 0.22 VDC

When the hot hand piece is touched to something cold:

U5 Pin 1 will pulse high momentarily

Characteristics of a cold MX Soldering Tip Cartridge:

Inductance at 1kHz is somewhere around 2.8 uH

DC resistance is fairly close to 0.21 ohms

ADDITIONAL INFORMATION:

For specifications and descriptions of operator controls and lights, please consult you Metcal Users Manual and the 1999 Metcal product catalog which can be found on the Internet via Google as of this writing.

US Patent Number 4626767 contains a wealth of additional technical information. US Patents are available for free on the Internet from various sources such as <http://www.freepatentsonline.com/>

MX-500P-11 SCHEMATIC DIAGRAM

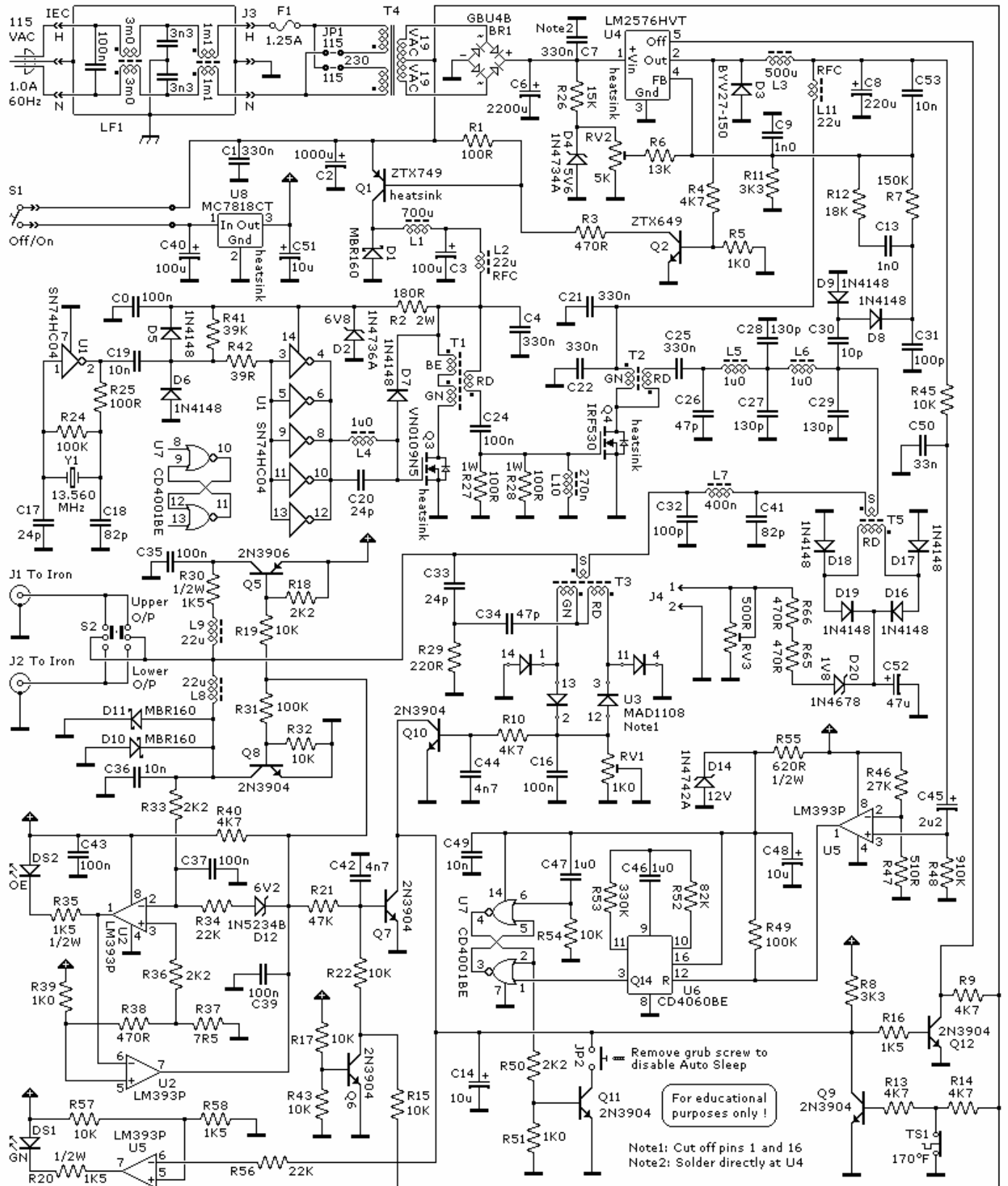

Note1: Cut off pins 1 and 16
 Note2: Solder directly at U4

For educational purposes only!

Remove grub screw to disable Auto Sleep

TS1 170°F

**MX-500P-11 CIRCUIT BOARD
PARTS PLACEMENT DIAGRAM**

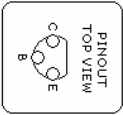

For educational purposes only!

NOTES:
 * SOLDER C7 DIRECTLY TO U4 PINS 1 & 3 ON REAR OF PCB
 * MAKE U3 INTO A 14 PIN IC BY CUTTING OFF PINS 1 & 16
 * SEMICONDUCTORS Q3 Q4 U8 & Q1 HAVE HEATSINKS
 * Q4 IS DOUBLE SHIELDED & INSULATED FROM HEATSINK
 * Q3 IS INSULATED FROM HEATSINK

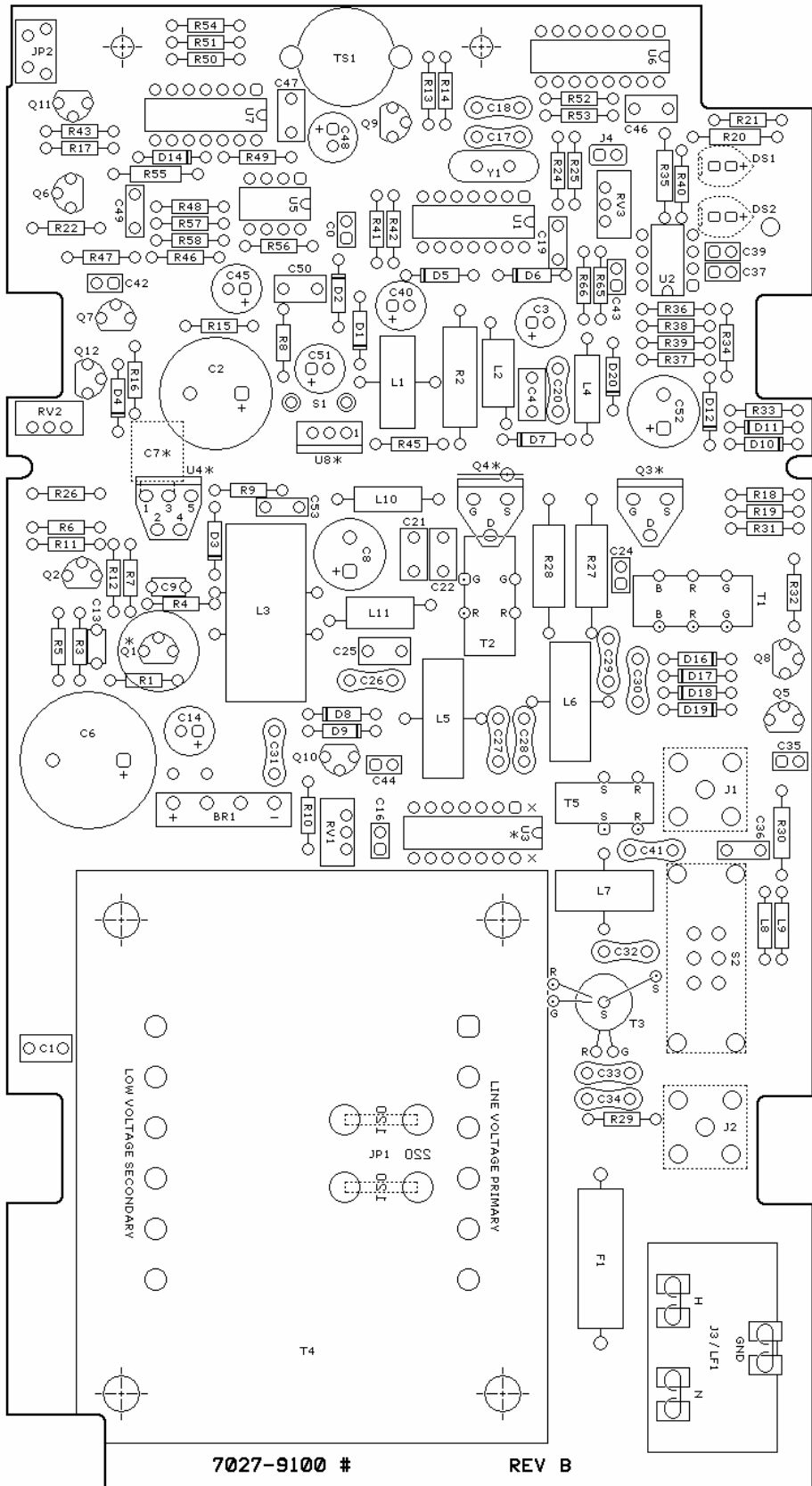

MX-500P-11 CIRCUIT BOARD PARTS LIST

BR1	Bridge Rectifier 4A 100V (GBU4B)	D7	Small Signal Silicon Diode (1N4148)
C0	100nF 63V 5% Polyester (WIMA MKS02 PCM2.5)	D8	Small Signal Silicon Diode (1N4148)
C1	330nF 63V 5% Polyester (WIMA MKS2 PCM5)	D9	Small Signal Silicon Diode (1N4148)
C2	1000uF 35V Aluminum Electrolytic	D10	Schottky Rectifier 1A 60V (MBR160 or SR160)
C3	100uF 35V Aluminum Electrolytic	D11	Schottky Rectifier 1A 60V (MBR160 or SR160)
C4	330nF 63V 5% Polyester (WIMA MKS2 PCM5)	D12	Zener Diode 6.2V 500mW (1N5234B)
C6	2200uF 50V Aluminum Electrolytic	D14	Zener Diode 12V 1W (1N4742A)
C7*	330nF 63V 5% Polyester (WIMA MKS2 PCM5)	D16	Small Signal Silicon Diode (1N4148)
C8	220uF 63V Aluminum Electrolytic	D17	Small Signal Silicon Diode (1N4148)
C9	1n0F 200V 10% Ceramic (CK05BX102K 200V)	D18	Small Signal Silicon Diode (1N4148)
C13	1n0F 200V 10% Ceramic (CK05BX102K 200V)	D19	Small Signal Silicon Diode (1N4148)
C14	10uF 35V Aluminum Electrolytic	D20	Zener Diode 1.8V 500mW (1N4678)
C16	100nF 63V 5% Polyester (WIMA MKS02 PCM2.5)	DS1	Green Rectangular LED 2x5mm
C17	24pF 500V 5% SilverMica (CM05ED240J03)	DS2	Orange Rectangular LED 2x5mm
C18	82pF 500V 5% SilverMica (CM05ED820J03)	F1	Time Delay Fuse 1.25A/250V (LittleFuse 239)
C19	10nF 200V 10% Ceramic (CK06BX103K 200V)	J1	PCB Mounted Connector Female Type F
C20	24pF 500V 5% SilverMica (CM05ED240J03)	J2	PCB Mounted Connector Female Type F
C21	330nF 63V 5% Polyester (WIMA MKS2 PCM5)	J3	PCB Mounted Female Quick-Connects
C22	330nF 63V 5% Polyester (WIMA MKS2 PCM5)	J4	Unshrouded Header Two Pin 0.1 Inch Pitch
C24	100nF 63V 5% Polyester (WIMA MKS02 PCM2.5)	JP1	Line Voltage Selection Strapping on PCB
C25	330nF 63V 5% Polyester (WIMA MKS2 PCM5)	JP2	Miniature PCB Mount Pushbutton Switch
C26	47pF 500V 5% SilverMica (CM05ED470J03)	L1	700uH Toroidal Inductor Many Turns
C27	130pF 500V 5% SilverMica (CM05ED131J03)	L2	22uH RF Choke 6-Port Bead
C28	130pF 500V 5% SilverMica (CM05ED131J03)	L3	500uH Toroidal Inductor 94.75 Turns
C29	130pF 500V 5% SilverMica (CM05ED131J03)	L4	1u0H Inductor DRWW
C30	10pF 500V 5% SilverMica (CM05ED100J03)	L5	1u0H Toroidal Inductor 16.75 Turns
C31	100pF 500V 5% SilverMica (CM05ED101J03)	L6	1u0H Toroidal Inductor 16.75 Turns
C32	100pF 500V 5% SilverMica (CM05ED101J03)	L7	400nH Toroidal Inductor 10.75 Turns
C33	24pF 500V 5% SilverMica (CM05ED240J03)	L8	22uH Inductor DRWW
C34	47pF 500V 5% SilverMica (CM05ED470J03)	L9	22uH Inductor DRWW
C35	100nF 63V 5% Polyester (WIMA MKS02 PCM2.5)	L10	270nH Inductor DRWW
C36	10nF 200V 10% Ceramic (CK06BX103K 200V)	L11	22uH RF Choke 6-Port Bead
C37	100nF 63V 5% Polyester (WIMA MKS02 PCM2.5)	LF1	Two Stage Line Filter (Delta 03SEEG3H)
C39	100nF 63V 5% Polyester (WIMA MKS02 PCM2.5)	Q1*	PNP 1 Watt Transistor (ZTX749)
C40	100uF 35V Aluminum Electrolytic	Q2	NPN 1 Watt Transistor (ZTX649)
C41	82pF 500V 5% SilverMica (CM05ED820J03)	Q3*	N-Channel Power MOSFET (VN0109N5)
C42	4n7F 63V 5% Polyester (WIMA MKS02 PCM2.5)	Q4*	N-Channel Power MOSFET (IRF530)
C43	100nF 63V 5% Polyester (WIMA MKS02 PCM2.5)	Q5	PNP Small Signal Transistor (2N3906)
C44	4n7 63V 5% Polyester (WIMA MKS02 PCM2.5)	Q6	NPN Small Signal Transistor (2N3904)
C45	2u2F 50V Dipped Tantalum	Q7	NPN Small Signal Transistor (2N3904)
C46	1u0F 63V 5% Polyester (WIMA MKS2 PCM5)	Q8	NPN Small Signal Transistor (2N3904)
C47	1u0F 63V 5% Polyester (WIMA MKS2 PCM5)	Q9	NPN Small Signal Transistor (2N3904)
C48	10uF 35V Aluminum Electrolytic	Q10	NPN Small Signal Transistor (2N3904)
C49	10nF 200V 10% Ceramic (CK06BX103K 200V)	Q11	NPN Small Signal Transistor (2N3904)
C50	33nF 63V 5% Polyester (WIMA MKS2 PCM5)	Q12	NPN Small Signal Transistor (2N3904)
C51	10uF 35V Aluminum Electrolytic		
C52	47uF 63V Aluminum Electrolytic		
C53	10nF 200V 10% Ceramic (CK06BX103K 200V)		
D1	Schottky Rectifier 1A 60V (MBR160 or SR160)		
D2	Zener Diode 6.8V 1W (1N4736A)		
D3	Fast Avalanche Rectifier 2A 150V (BYV27-150)		
D4	Zener Diode 5.6V 1W (1N4734A)		
D5	Small Signal Silicon Diode (1N4148)		
D6	Small Signal Silicon Diode (1N4148)		

Continuation and notes on next page...

MX-500P-11 CIRCUIT BOARD PARTS LIST

R1	100R 1/4W 5% Carbon Film	R65	470R 1/4W 5% Carbon Film
R2	180R 2W 5% Carbon Film or Metal Film	R66	470R 1/4W 5% Carbon Film
R3	470R 1/4W 5% Carbon Film		
R4	4K7 1/4W 5% Carbon Film	RV1	Linear 1 Turn Trimpot 1K0 1/2W (Bourns 3386)
R5	1K0 1/4W 5% Carbon Film	RV2	Linear 1 Turn Trimpot 5K0 1/2W (Bourns 3386)
R6	13K 1/4W 5% Carbon Film	RV3	Linear 1 Turn Trimpot 500R 1/2W (Bourns 3386)
R7	150K 1/4W 5% Carbon Film		
R8	3K3 1/4w 5% Carbon Film	S1	Power Switch 15A 125VAC (C&K Series CA)
R9	4K7 1/4W 5% Carbon Film	S2	PCB Mount DPDT Slide Switch
R10	4K7 1/4W 5% Carbon Film		
R11	3K3 1/4W 5% Carbon Film	T1	Transformer Toroidal 9uH Each Winding (Three Windings With 10.75 Turns Each)
R12	18K 1/4W 5% Carbon Film	T2	Transformer Toroidal 9uH Each Winding (Two Windings With 10.75 Turns Each)
R13	4K7 1/4W 5% Carbon Film	T3	Current Transformer Toroidal 6uH Secondary (Primary 1.75 Turns, Secondary 9.75 Turns)
R14	4K7 1/4W 5% Carbon Film		
R15	10K 1/4W 5% Carbon Film	T4	Line Transformer 38VAC Secondary With CT (Metcal Part No: MP100-2-536XA 5600-0025)
R16	1K5 1/4W 5% Carbon Film	T5	Current Transformer Bifilar Toroidal 12uH Sec (Primary 1.75 Turns, Secondary 54.75 Turns)
R17	10K 1/4W 5% Carbon Film		
R18	2K2 1/4W 5% Carbon Film	TS1	Overtemperature Switch 170F Normally Closed (Selco OA-170-PCB US-602 S)
R19	10K 1/4W 5% Carbon Film		
R20	1K5 1/2W 5% Carbon Film	U1	Hex Inverter (SN74HC04N)
R21	47K 1/4W 5% Carbon Film	U2	Dual Voltage Comparator (LM393P)
R22	10K 1/4W 5% Carbon Film	U3*	Array Of 8 Independent Diodes (MAD1108)
R24	100K 1/4W 5% Carbon Film	U4*	3-Amp Step Down Switcher (LM2576HVT)
R25	100R 1/4W 5% Carbon Film	U5	Dual Voltage Comparator (LM393P)
R26	15K 1/4W 5% Carbon Film	U6	14-Bit Binary Counter & Oscillator (CD4060BE)
R27	100R 1W 5% Carbon Film or Metal Film	U7	Quad 2-Input NOR Gate (CD4001BE)
R28	100R 1W 5% Carbon Film or Metal Film	U8*	Voltage Regulator +18V 1A (MC7818CT)
R29	220R 1/4W 5% Carbon Film		
R30	1K5 1/2W 5% Carbon Film	Y1	Crystal 13.560MHz HC49U (ECX-1570 XX)
R31	100K 1/4W 5% Carbon Film		
R32	10K 1/4W 5% Carbon Film		
R33	2K2 1/4W 5% Carbon Film		
R34	22K 1/4W 5% Carbon Film		
R35	1K5 1/2W 5% Carbon Film		
R36	2K2 1/4W 5% Carbon Film		
R37	7R5 1/4W 5% Carbon Film or Metal Film		
R38	470R 1/4W 5% Carbon Film		
R39	1K0 1/4W 5% Carbon Film		
R40	4K7 1/4W 5% Carbon Film		
R41	39K 1/4W 5% Carbon Film		
R42	39R 1/4W 5% Carbon Film		
R43	10K 1/4W 5% Carbon Film		
R44	10K 1/4W 5% Carbon Film		
R45	10K 1/4W 5% Carbon Film		
R46	27K 1/4W 5% Carbon Film		
R47	510R 1/4W 5% Carbon Film		
R48	910K 1/4W 5% Carbon Film		
R49	100K 1/4W 5% Carbon Film		
R50	2K2 1/4W 5% Carbon Film		
R51	1K0 1/4W 5% Carbon Film		
R52	82K 1/4W 5% Carbon Film		
R53	330K 1/4W 5% Carbon Film		
R54	10K 1/4W 5% Carbon Film		
R55	620R 1/2W 5% Carbon Film		
R56	22K 1/4W 5% Carbon Film		
R57	10K 1/4W 5% Carbon Film		
R58	1K5 1/4W 5% Carbon Film		

NOTES

Solder C7 directly to U4 pins 1 & 3 on rear of PCB.
 Make U3 into a 14 pin IC by cutting off pins 1 & 16.
 Semiconductors Q3 Q4 U4 U8 & Q1 have heatsinks.
 Q4 is double shielded and insulated from heatsink.
 Q3 is insulated from heatsink.

! MIRROR VIEW THROUGH BOTTOM OF PCB FOR TROUBLESHOOTING PURPOSES !

