

# W2000A

# OPA653

# Mod

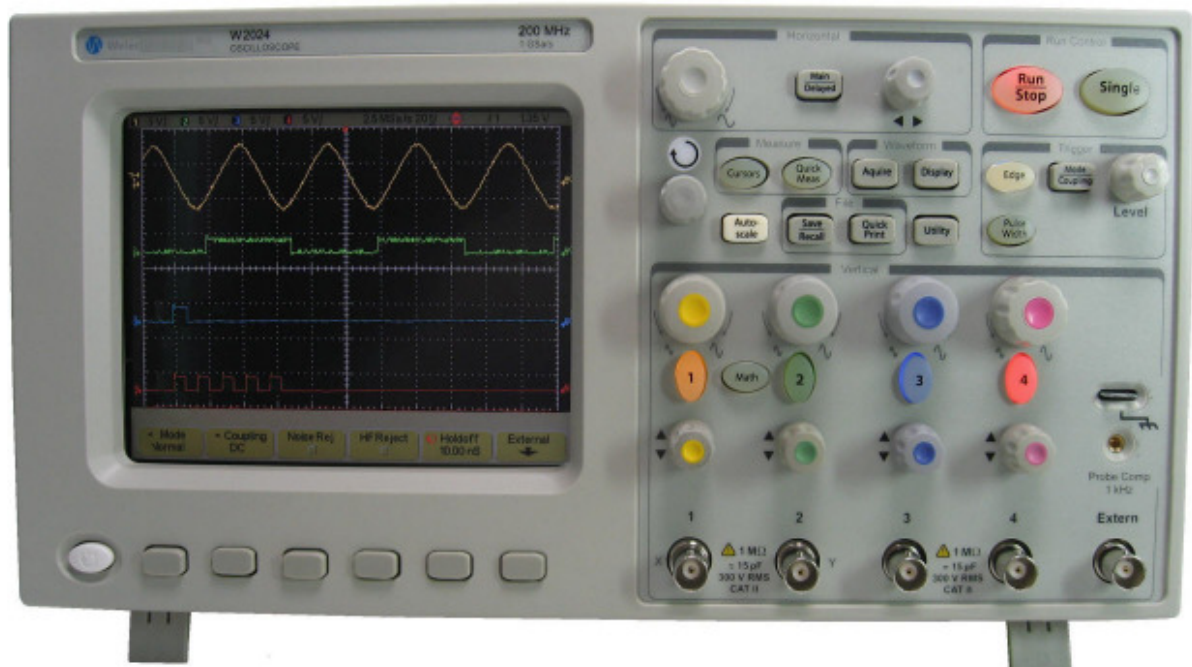

**Table of contents**

**Preface ..... 2**  
**Dimensioning ..... 3**  
**Implementation..... 4**  
    Main PCB removal ..... 4  
    Remove shieldings ..... 6  
    Feedback circuit and compensation network ..... 7  
    R13, R14 and the series resistors ..... 8  
    OPA656 and switch U<sub>3</sub> ..... 9  
    The terminating resistor ..... 10  
**Final steps..... 11**  
**The Result ..... 12**  
**Bill of Material..... 12**

## Preface

Basing on the results we got from the Low Budget Mod the next step will be to increase the bandwidth.

The AD8131 amplifier has a bandwidth of 400MHz when using a small load. In this case the OPA656 is the limiting factor. It is obvious that a replacement with more bandwidth would be the best possibility. All other parameters should be similar.

The OPA653 comes up to this demand. This amplifier is equipped with a FET input stage providing a high input resistance but low noise. The slew rate is much faster than the OPA656s and the frequency response is almost linear with a 3dB bandwidth of 500MHz. The gain is fixed at 2 with internal feedback resistors.

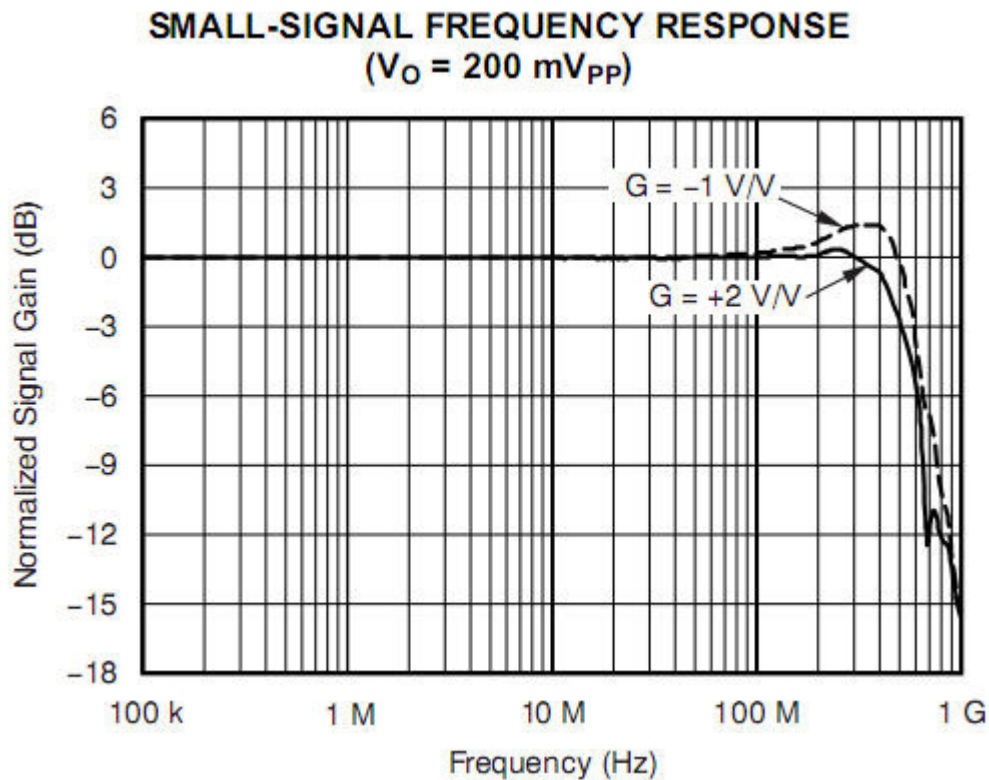

Fig 1: Frequency response OPA653

### Key data

Bandwidth:	500MHz	(vs. 200MHz, Gain 2 OPA656)
Slew rate:	800V/ $\mu\text{s}$ (1V Step)	(vs. 290V/ $\mu\text{s}$ OPA656)
Input noise:	6.1nV/ $\sqrt{\text{Hz}}$	(vs. 7nV/ $\sqrt{\text{Hz}}$ OPA656)

In the Low Budget Mod the OPA656 works with a gain of 1.9 using resistor values of 24.9 to 330Ω at the output of the last AD8131 has proved optimal. Therefore our goal is to decrease the gain of the OPA653 so far, that the resulting gain of the amplifier chain becomes similar to the LB-Mod.. That might make it possible to use a mixed mounting of OPA653 and OPA656.

## Dimensioning

The frequency response of the OPA653 (Fig 1) is almost linear. That makes a frequency correction how it is done for the OPA656, superfluous. The compensation network R22 and C12 and the switch U3 can be removed completely. Desoldering U3 is recommended because it is without function and grants a better access to OPA656/OPA653. U3 also might act as a capacitor to the OPAs input.

The OPA653 got its feedback resistor integrated in the case. Therefore R21 can also be removed. For adjusting the gain and the zero level the resistors R13 and R14 have to be replaced with new values. By trial and error I found the combination R13 = 390KΩ and R14 = 100Ω which is working properly.

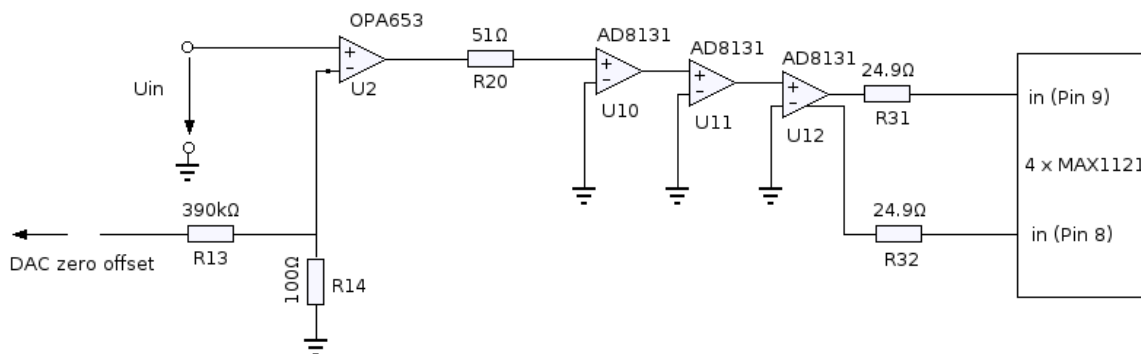

Fig 2: New input stage with OPA653

To avoid lost of bandwidth, it is recommendable to use a load with high resistance. Removing the terminating resistor R<sub>A</sub> results in  $R_{31} + R_{32} + 4 \parallel \text{ADCin} = 1.15\text{K}\Omega$ . The frequency response with this values is shown in Fig. 3.

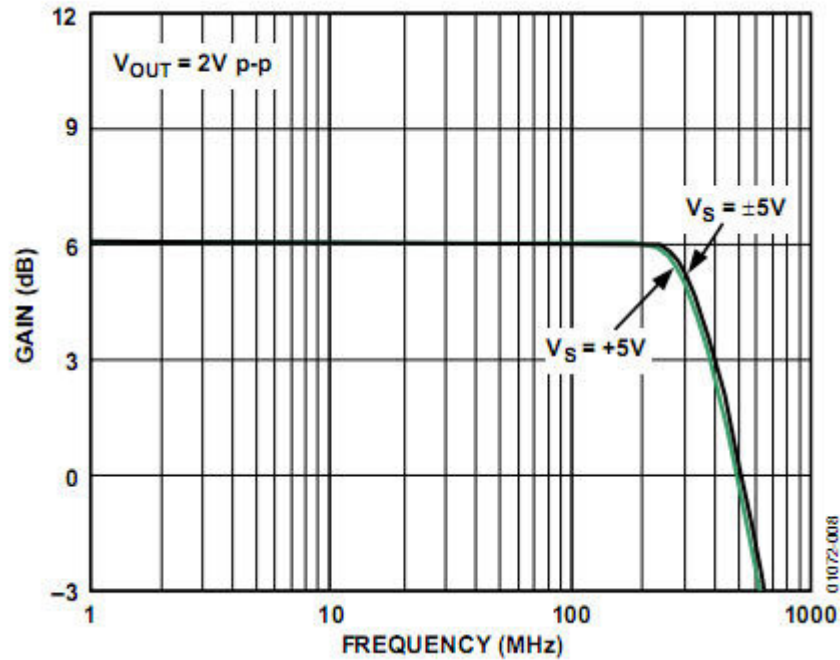

Fig 3: Frequency response AD8131 with 1,15K $\Omega$  termination

Details of the original input stage can be found in the Low Budget Mod documentation.

## Implementation

### Main PCB removal

First the main PCB has to be removed. To achieve this, the knobs of the front panel have to be removed. Otherwise we won't get to the BNC mounts. The knobs sit very tightly, but can be pried off with a small screwdriver. Set the screwdriver against the rim where the flattened part of the shaft begins.

Remove the back cover (three bolts). The power supply is on one side, the main board on the other. First we have to remove the power supply (4 bolts). Pull the board carefully off the headers. Then remove the two little plugs connecting the PSU to the display.

Next, remove the display connector and the bolts holding the main PCB. Now, remove the complete metal frame from the plastic front panel and remove the screws of the BNCs. The main PCB can now carefully be pried free. This works best at the place where the little screw was. The PCB then pops off the connector below (Fig 4 - Connector 1) and can easily be removed.

For the following steps it is good to have the PCB lying flat and stable. I have cut two support blocks from packaging foam with a carpet knife.

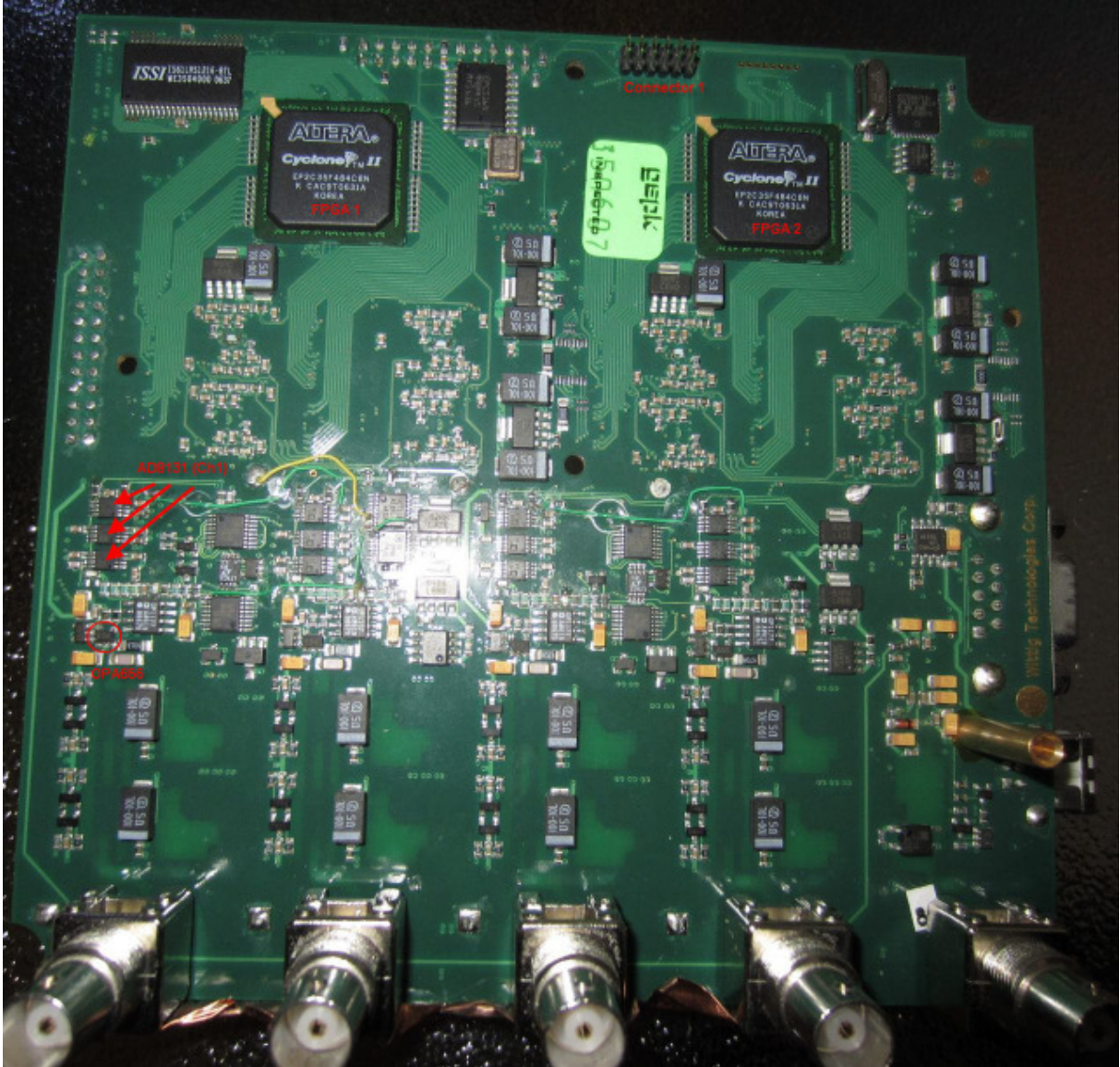

Fig 4: Main PCB

## Remove shieldings

Next you need the soldering iron. The tin shields over the input stages have to be removed. Each shield is soldered diagonally to the PCB at two points. In addition to that, there is a little wire to ground the BNCs (Fig 7). This can be done with a somewhat bigger soldering iron. At one solder joint some extra care is needed because an insulated wire runs through the hole.

Among other things, the OPA656's feedback circuit is under the shield. That is what we want to desolder.



Bild 5: Abschirmung

## Feedback circuit and compensation network

Remove resistor R22 (marked 390) and capacitor C12 lying side by side (Fig 6 with original components). R21 lying beneath R22 and C12 has to be desoldered too. These parts are not needed anymore, we leave the soldering pads empty.

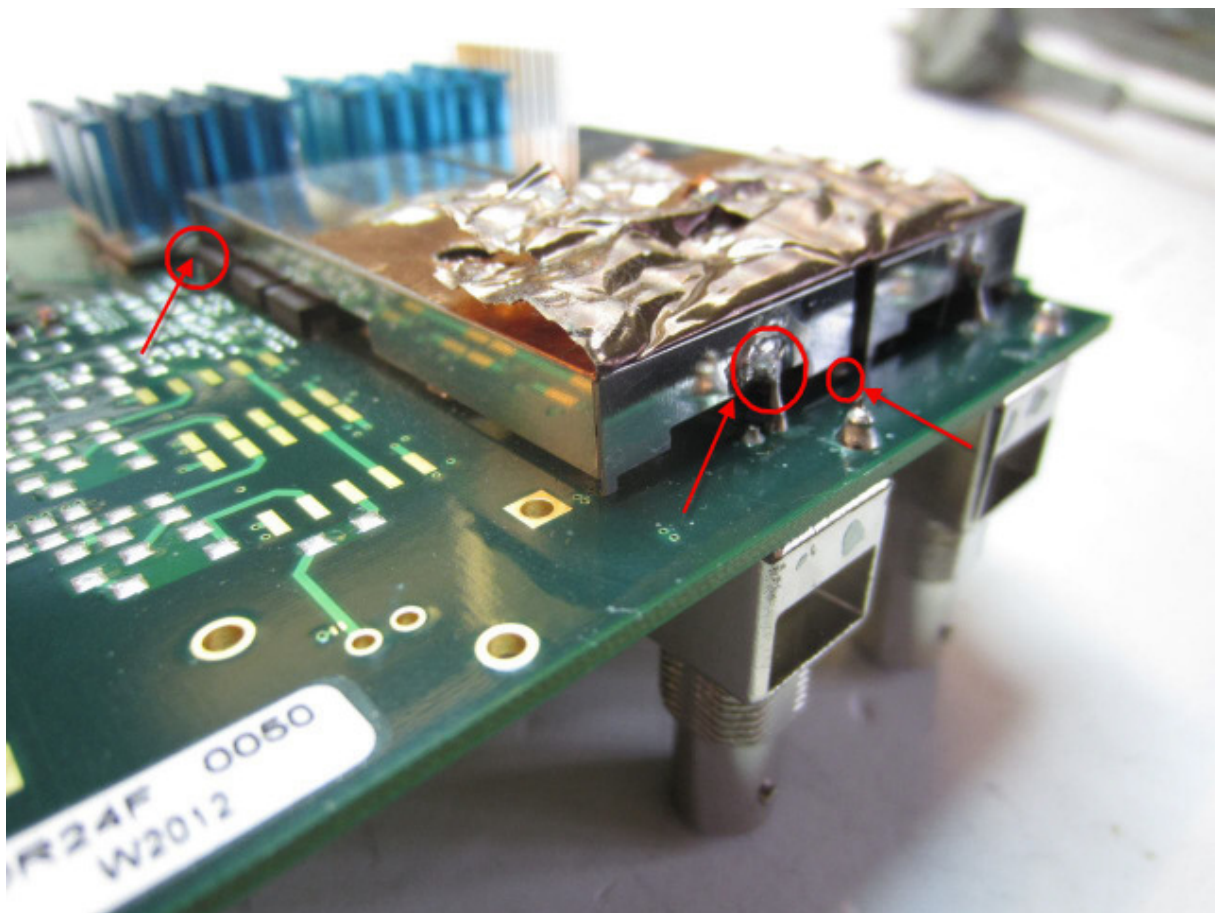
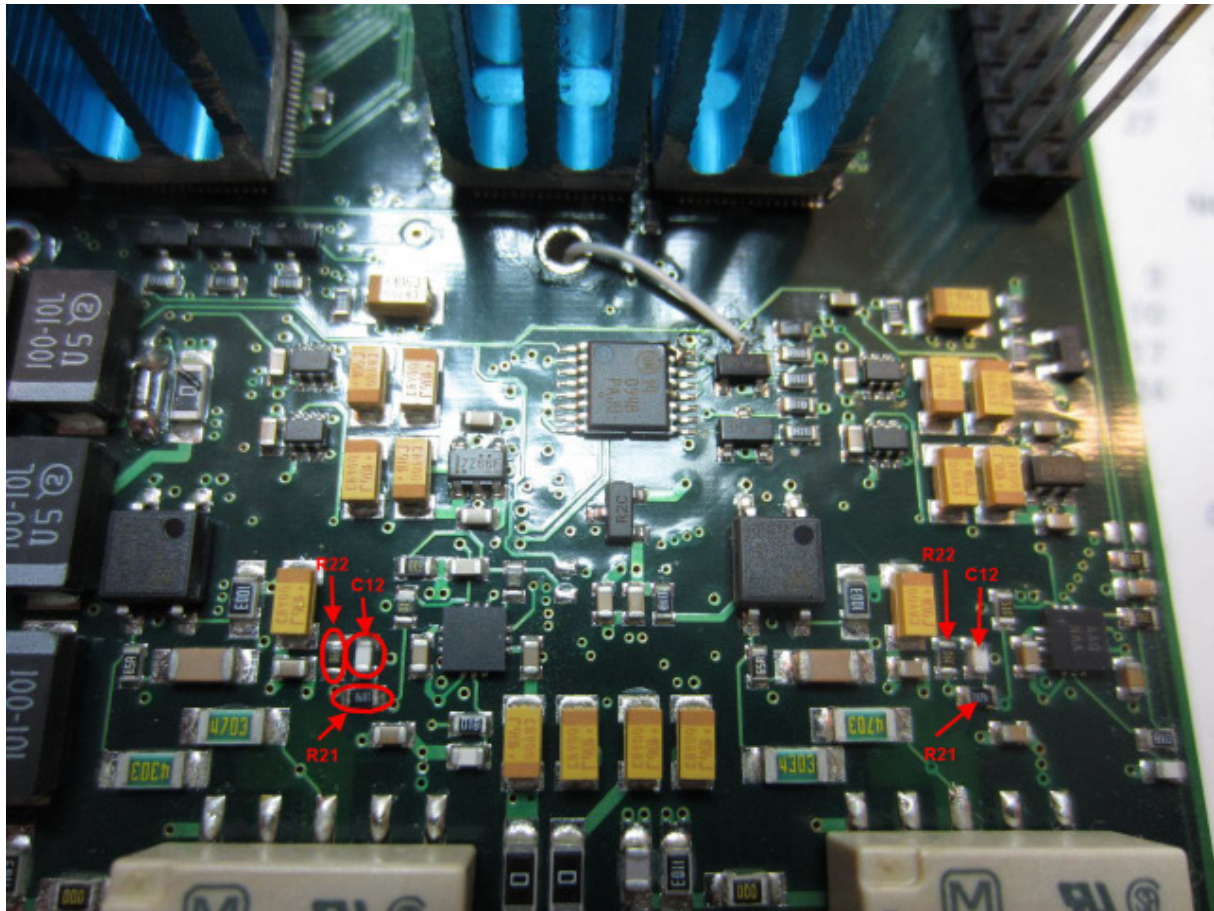

Fig 6: Feedback circuit R21 / R22 / C12

When working on that side of the PCB, please check the soldering of the variable capacitors. In my scope, all of them weren't soldered properly on one side.

That is it for that side of the board. We'll continue on the other side.



## R13, R14 and the series resistors

On the other side of the board, first locate the OPA656. Our R13 is located between the OPA656 and the first AD8131 (Fig 7). Shown here without marking. At his side we find R14. The original value is R14 = 750Ohms (marked: 751). Remove R14 and replace with 100Ohms (Marked 101). Remove R13 also and replace with a 390K $\Omega$  resistor.

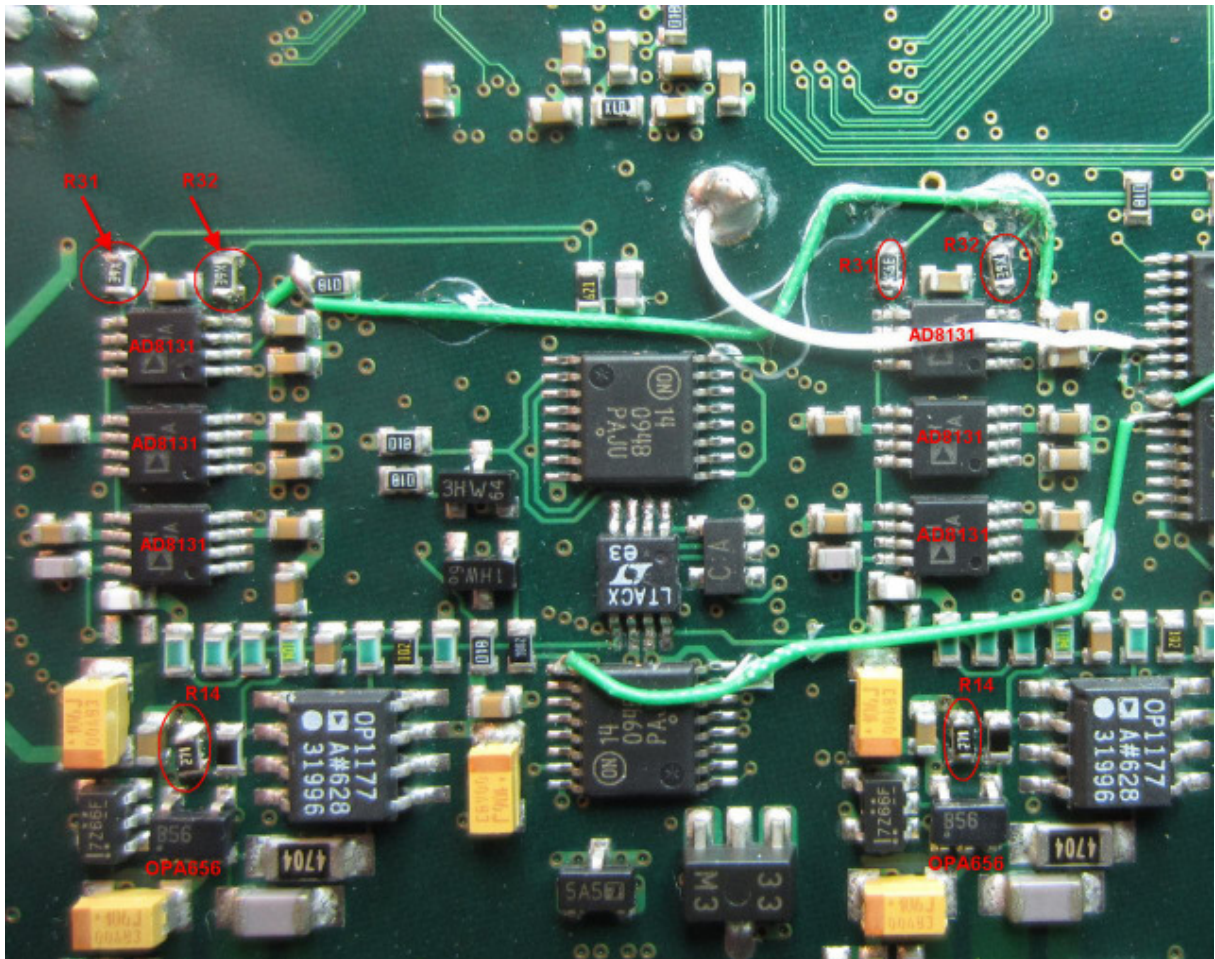

Fig 7: R13, R14 and the series resistors

The next step is to replace the series resistors R31 and R32. We'll find them near the last AD8131. Originally 0Ohms have been used. We'll replace them with 24.9Ohms (Marked: 39X) as seen in Fig 7.

## OPA656 and switch U3

When removing switch U3 it is much easier to desolder OPA656. The best way to desolder the 5 pins is to use two desoldering irons or a hot air rework station. Case and pin layout of the OPA653 are the same as the OPA656s. So it can be replaced 1:1.

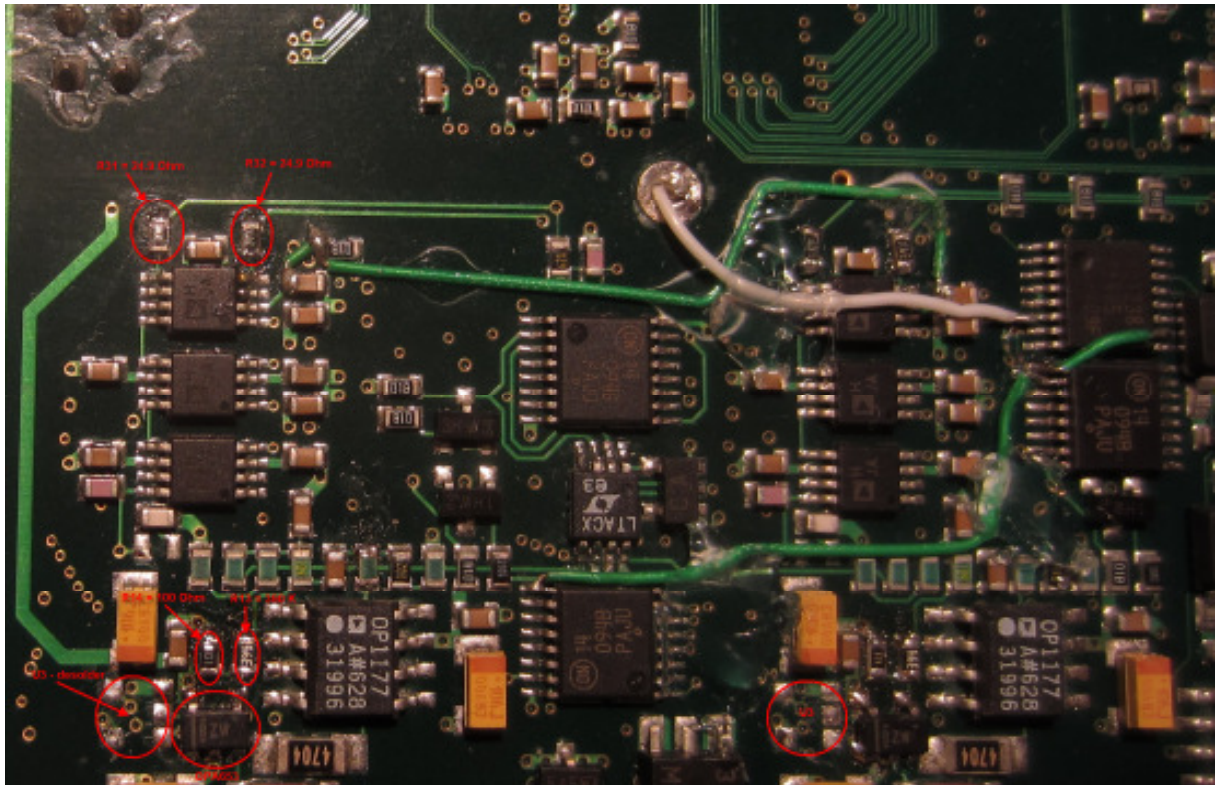

Fig 8: Mainboard with OPA653

## The terminating resistor

Now only the terminating resistor is missing from the ADC input. We find it somewhat above the series resistors towards the FPGA. The original value is 150KOhms (marked 154). In the meantime some have replaced them with 150Ohms, 174 Ohms or 180 Ohms.

In Fig 9, it is the bright blue resistor without markings. This is from a test with 180 Ohms.

We remove the resistor and leave the soldering pads empty.

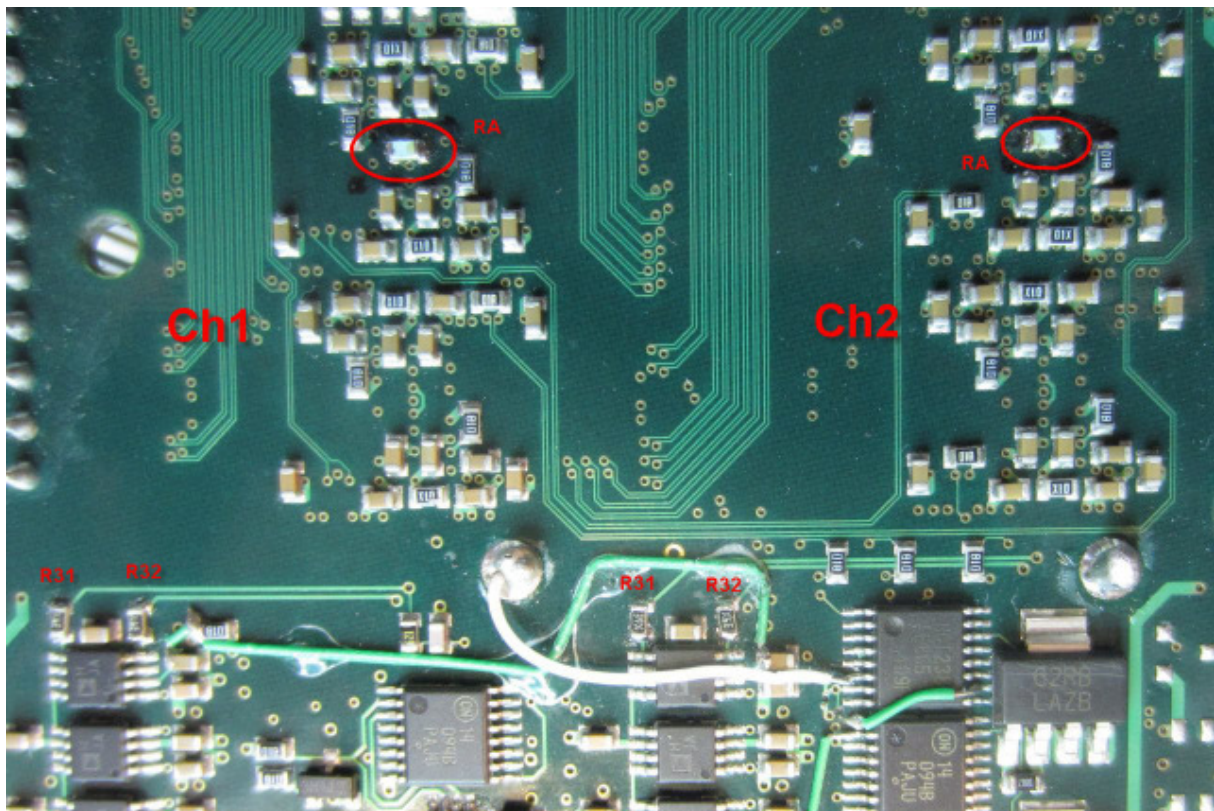

Fig 9: Terminator

## Final steps

After reassembly it is advisable to check the signal display. The whole effort to improve the signal representation is futile if the first amplifier stage causes distortions. To do this we need a square wave signal between 1kHz and 1MHz. The edges should have a rise time of less than 40 ns. The signal source must be connected through a link terminated at 50Ω. The probes are unsuitable because they influence the signal.

Adjust the pre-trigger to the left for the second grid division, so you can see the edge and enough of the positive part of the signal.

If you switch through the time bases, you can see the upper corner of the rising edge forming. It should neither be rounded, nor have too much of an overshooting spike. Ideally this should be a perfect angle. In reality, there will always be some overshoot (see Low Budget Mod).

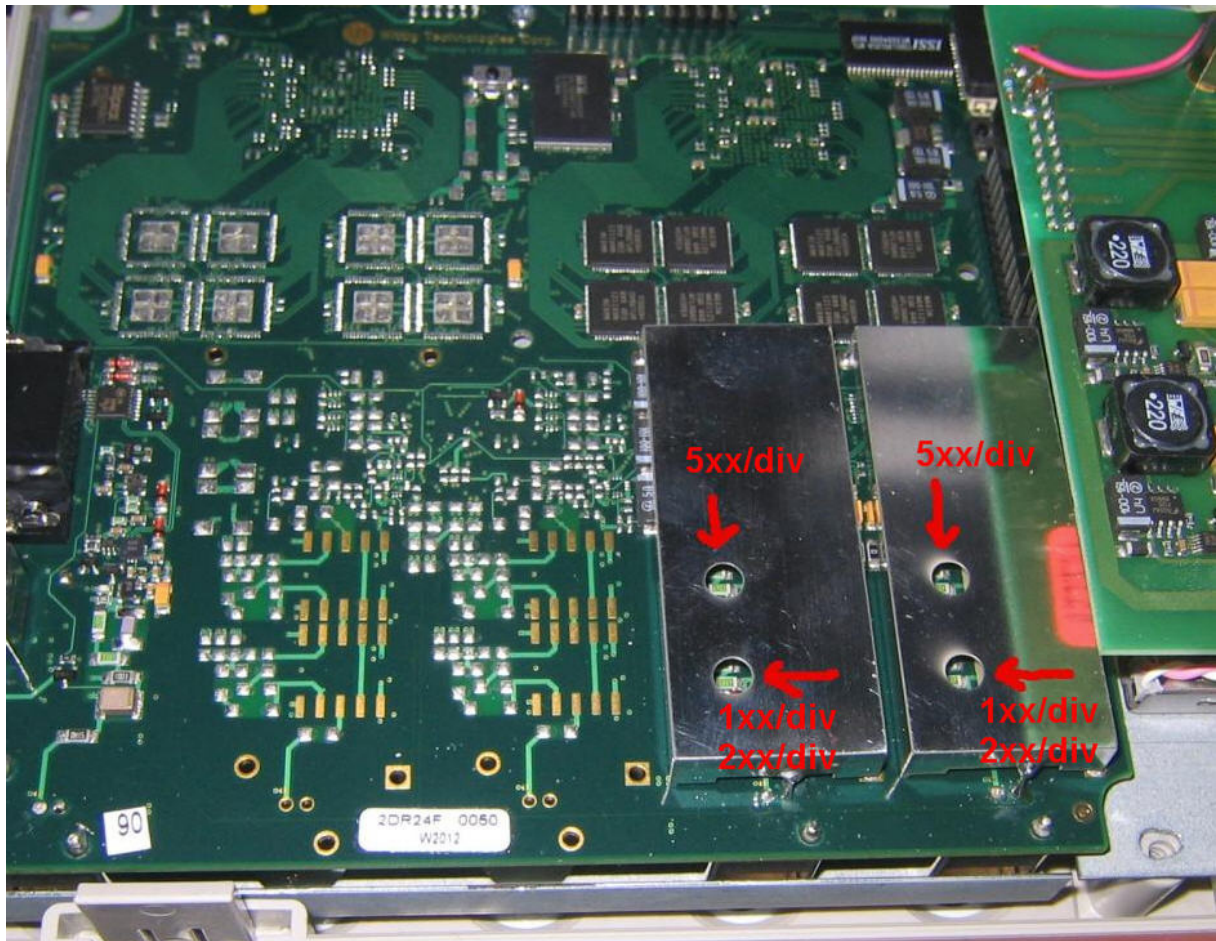

Fig 10: Input adjustment

## The Result

In Fig. 11 the frequency responses of the W2014A (blue) with Low Budget Mod, the W2022A (red) with OPA653 and the Owon SDS8102 (green) can be compared.

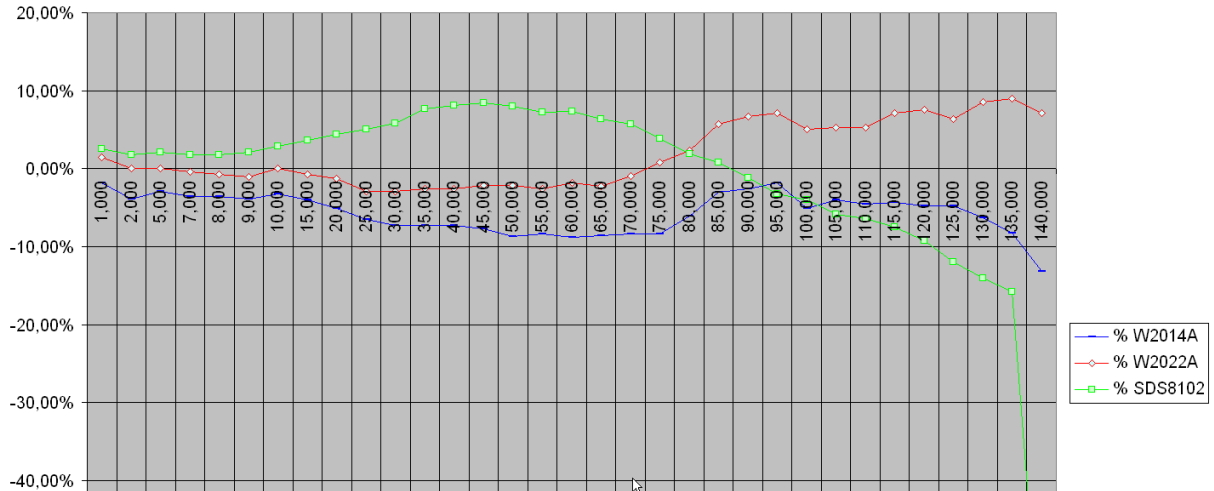

Fig 11: Frequency response

I took the measurements with a Leader 3216 sine wave generator. It's operational range of 1MHz to 140MHz covers the most relevant frequency range. As a reference I sampled all signal levels with a Tektronix 2465A.

## Bill of Material

Part Number	Value	Form factor	Number per channel
R13	390K $\Omega$ (1%)	SMD 0603	1
R14	100 $\Omega$ (1%)	SMD 0603	1
R31/R32	24.9 $\Omega$ (1%)	SMD 0603	2
OPA653	IDBVT	SOT23-5	1