

isc Silicon NPN Power Transistor

2SC4237

DESCRIPTION

- Collector-Emitter Sustaining Voltage-  
:  $V_{CEO(SUS)} = 800V(\text{Min})$
- Fast Switching speed

APPLICATIONS

- Color TV horizontal output applications

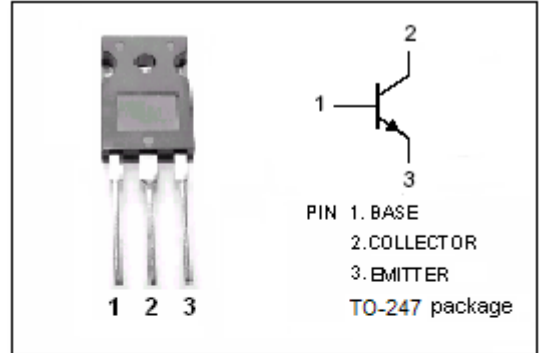

ABSOLUTE MAXIMUM RATINGS( $T_a=25^\circ\text{C}$ )

SYMBOL	PARAMETER	VALUE	UNIT
$V_{CBO}$	Collector-Base Voltage	1200	V
$V_{CEO}$	Collector-Emitter Voltage	800	V
$V_{EBO}$	Emitter-Base Voltage	7	V
$I_C$	Collector Current-Continuous	10	A
$I_{CM}$	Collector Current-Peak	20	A
$I_B$	Base Current-Continuous	4	A
$I_{BM}$	Base Current-Peak	8	A
$P_T$	Total Power Dissipation @ $T_C=25^\circ\text{C}$	150	W
$T_J$	Junction Temperature	150	$^\circ\text{C}$
$T_{stg}$	Storage Temperature Range	-55~150	$^\circ\text{C}$

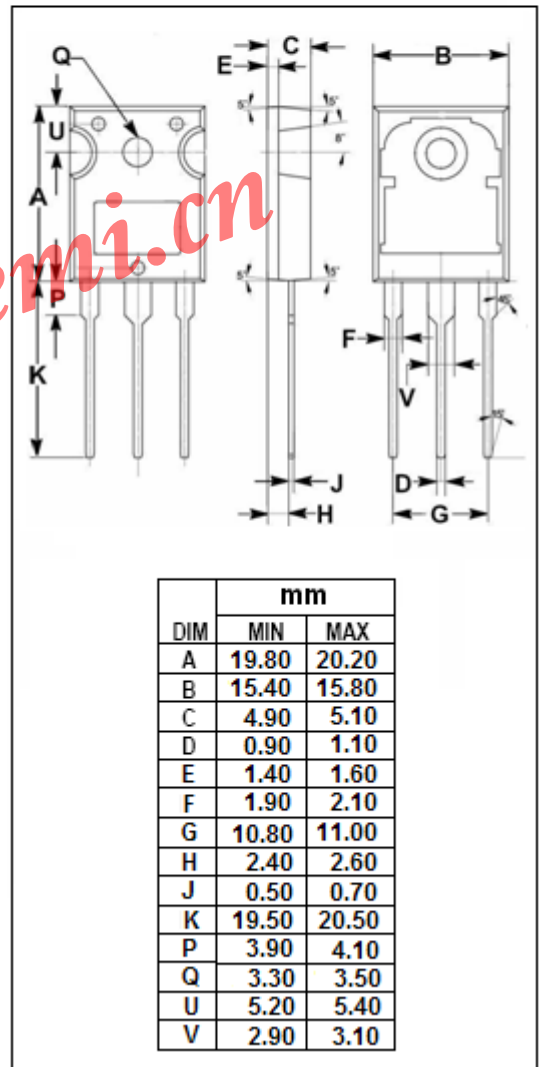

THERMAL CHARACTERISTICS

SYMBOL	PARAMETER	MAX	UNIT
$R_{th\ j-c}$	Thermal Resistance, Junction to Case	0.83	$^\circ\text{C/W}$

## isc Silicon NPN Power Transistor

2SC4237

## ELECTRICAL CHARACTERISTICS

 $T_C=25^\circ\text{C}$  unless otherwise specified

SYMBOL	PARAMETER	CONDITIONS	MIN	TYP.	MAX	UNIT
$V_{CE(SUS)}$	Collector-Emitter Sustaining Voltage	$I_C=0.2\text{A}; I_B=0$	800			V
$V_{CE(sat)}$	Collector-Emitter Saturation Voltage	$I_C=5\text{A}; I_B=1\text{A}$			1.0	V
$V_{BE(sat)}$	Base-Emitter Saturation Voltage	$I_C=5\text{A}; I_B=1\text{A}$			1.5	V
$I_{CBO}$	Collector Cutoff Current	At rated Voltage			100	$\mu\text{A}$
$I_{CEO}$	Collector Cutoff Current	At rated Voltage			100	$\mu\text{A}$
$I_{EBO}$	Emitter Cutoff Current	At rated Voltage			100	$\mu\text{A}$
$h_{FE-1}$	DC Current Gain	$I_C=5\text{A}; V_{CE}=5\text{V}$	8			
$h_{FE-2}$	DC Current Gain	$I_C=1\text{mA}; V_{CE}=5\text{V}$	5			
$f_T$	Current-Gain—Bandwidth Product	$I_C=1\text{A}; V_{CE}=10\text{V}$		8		MHz

## Switching times

$t_{on}$	Turn-on Time	$I_C=5\text{A}, I_{B1}=1\text{A}; I_{B2}=-2\text{A}$ $R_L=50\Omega; V_{BB2}=4\text{V}$			0.5	$\mu\text{s}$
$t_{stg}$	Storage Time				3.5	$\mu\text{s}$
$t_f$	Fall Time				0.3	$\mu\text{s}$

isc Silicon NPN Power Transistor

2SC4237

$h_{FE}-I_C$  Characteristics

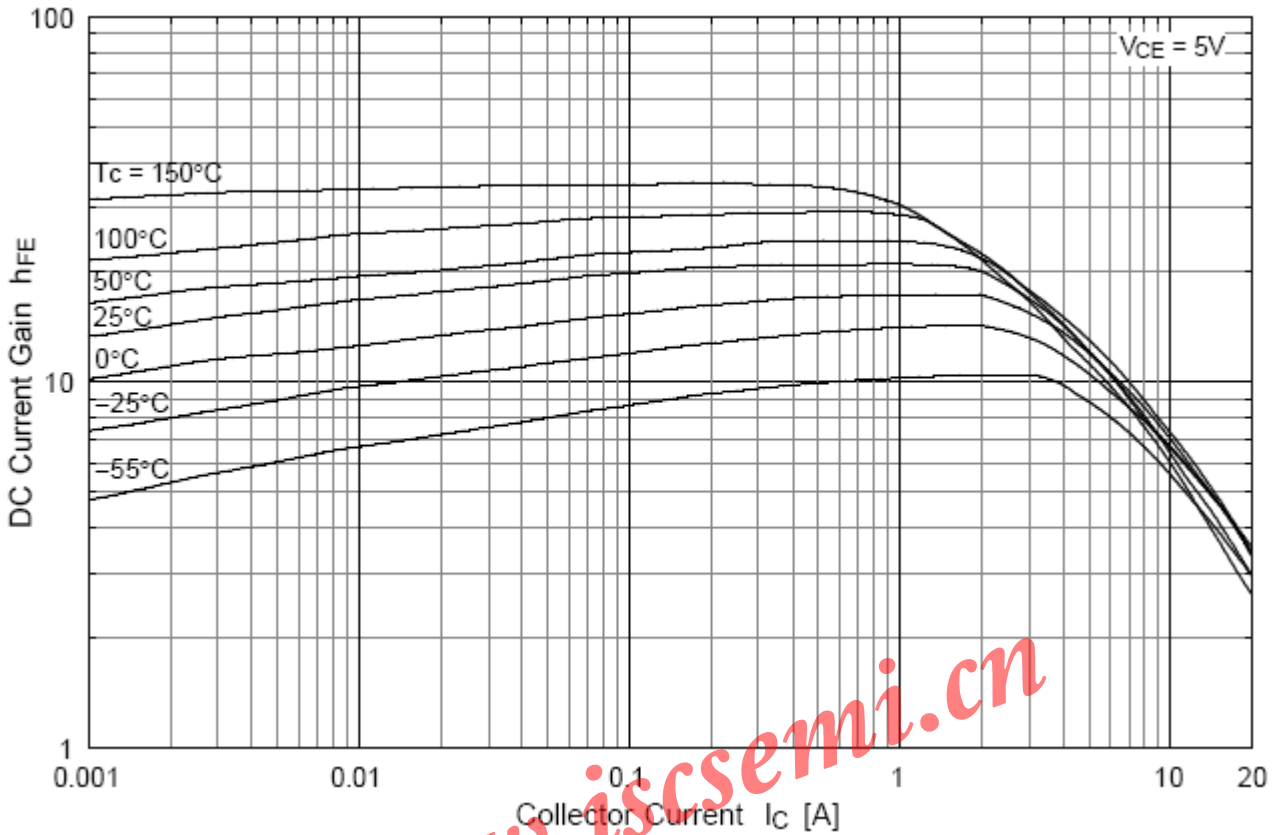

$V_{CE(sat)}-I_B$  &  $V_{BE(sat)}-I_B$  Characteristics

