

### ① PHYSICAL DIMENSION

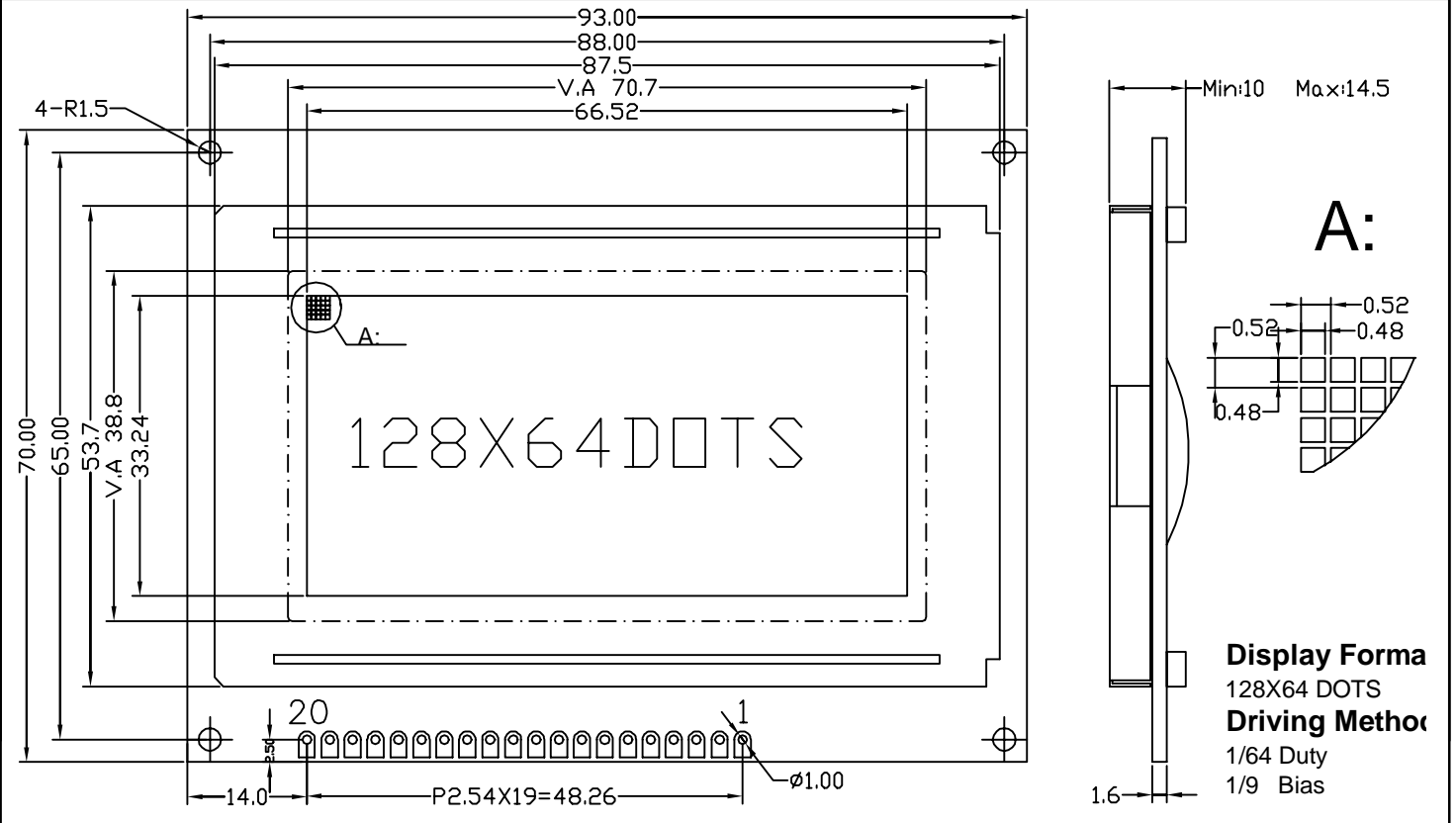

### ② MECHANICAL DATA

ITEM	SPECIFICATION	UNIT
Module Size With B/L (W X H X T)	93.0 X 70.0 X 14.5	mm
Viewing Area (W X H)	70.7 X 38.8	mm
Number of Dots (W X H)	128 X 64	dots
Dot Pitch (W X H)	0.52 X 0.52	mm
Dot Size (W X H)	0.48 X 0.48	mm
Weight	70.0 (With B/L)	g

### ④ BLOCK DIAGRAM

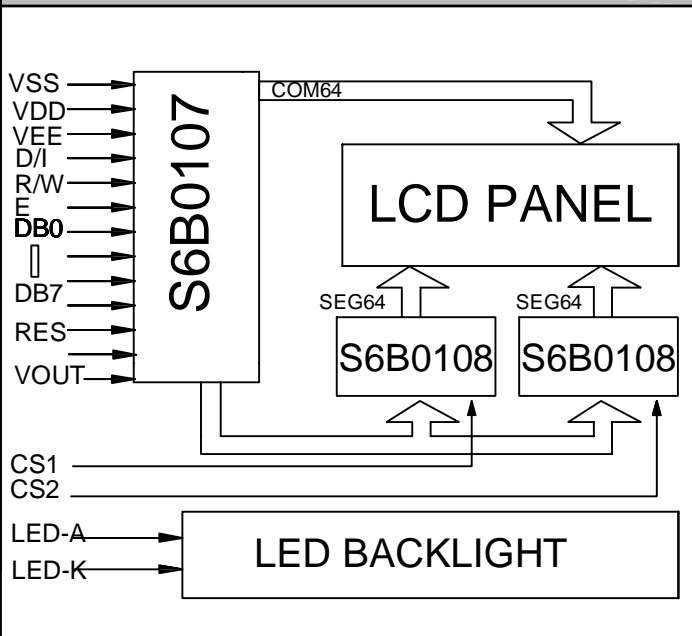

### ③ PIN CONFIGURATION

ITEM	SYMBOL	DESCRIPTION	
1	VSS	Power ground	
2	VDD	Power positive (+5V+10%).	
3	V0	Operating voltage for LCD Driver(variable)	
4	D/I	H:Data L:Instruction Code	
5	R/W	Read or Write.	
6	E	Enable trigger.	
7	DB0	Data bus [0~7]. These state I/O common terminal.	
14	DB7		
15	CS1		Chip 1 Select
16	CS2		Chip 2 Select
17	RESET		System reset low active.
18	VEE		Supply Voltage for LCD Drive.
19	LED_A		BACKLIGHT ANODE(+5V) .
20	LED_K		BACKLIGHT CATHODE (0V).

### ⑤ ABSOLUTE MAXIMUM RATINGS (25°C)

PARAMETER	SYMBOL	MIN.	MAX.	UNIT
SUPPLY VOLTAGE LOGIC	VDD	0	5.5	V
SUPPLY VOLTAGE DRIVER	VDD-VEE	0	15	V
INPUT VOLTAGE	VIN	0	VDD	V