

# Silicon Laboratories

## Mixed-Signal MCU Selector Guide

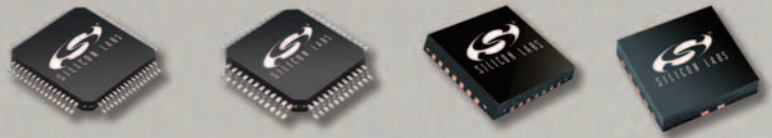
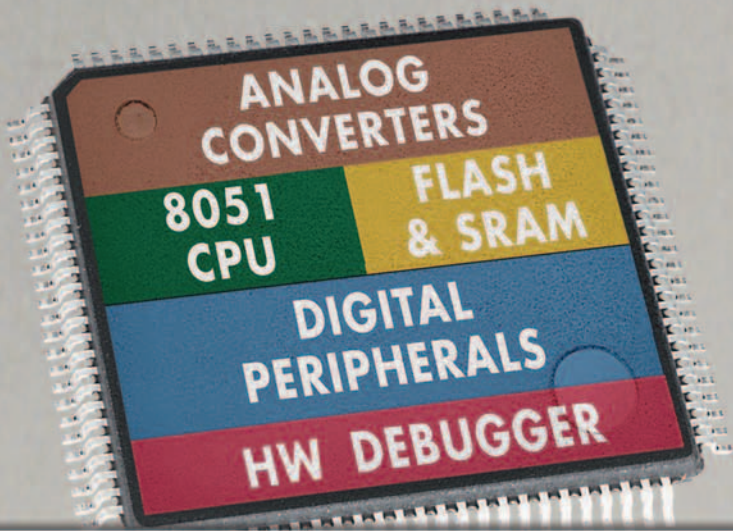

[www.silabs.com](http://www.silabs.com)

### High-Performance 8051 Mixed-Signal Microcontrollers

- Highest Performance Integrated Analog
  - Up to 24-bit ADCs
  - Up to 1 Msps ADCs
- World's Fastest 8-bit MCU
  - Up to 100 MIPS
- Smallest MCU Footprint
  - 3 x 3 mm
- Comprehensive, Low Cost Development Tools



# Precision Mixed-Signal MCUs

Part Number	MIPS (peak)	Flash (bytes)	RAM (bytes)	Ext Mem I/F	Digital Port I/O Pins	Serial Buses	Timers (16-bit)	PCA Chnls	Internal Osc	ADC1	ADC2	DAC	Temp Sensor	VREF	Comparators	Other	Package	Dev Kit
C8051F120	100	128 kB	8448	Y	64	2 UARTs, SMBus, SPI	5	6	±2%	12-bit, 8-ch., 100 ksps	8-bit, 8-ch., 500 ksps	12-bit, 2-ch.	Y	Y	2	16x16 MAC	TQFP100	C8051F120DK
C8051F121	100	128 kB	8448	Y	32	2 UARTs, SMBus, SPI	5	6	±2%	12-bit, 8-ch., 100 ksps	8-bit, 8-ch., 500 ksps	12-bit, 2-ch.	Y	Y	2	16x16 MAC	TQFP64	C8051F120DK
C8051F122	100	128 kB	8448	Y	64	2 UARTs, SMBus, SPI	5	6	±2%	10-bit, 8-ch., 100 ksps	8-bit, 8-ch., 500 ksps	12-bit, 2-ch.	Y	Y	2	16x16 MAC	TQFP100	C8051F120DK
C8051F123	100	128 kB	8448	Y	32	2 UARTs, SMBus, SPI	5	6	±2%	10-bit, 8-ch., 100 ksps	8-bit, 8-ch., 500 ksps	12-bit, 2-ch.	Y	Y	2	16x16 MAC	TQFP64	C8051F120DK
C8051F130	100	128 kB	8448	Y	64	2 UARTs, SMBus, SPI	5	6	±2%	10-bit, 8-ch., 100 ksps	-	-	Y	Y	2	16x16 MAC	TQFP100	C8051F120DK
C8051F131	100	128 kB	8448	Y	32	2 UARTs, SMBus, SPI	5	6	±2%	10-bit, 8-ch., 100 ksps	-	-	Y	Y	2	16x16 MAC	TQFP64	C8051F120DK
C8051F132	100	64 kB	8448	Y	64	2 UARTs, SMBus, SPI	5	6	±2%	10-bit, 8-ch., 100 ksps	-	-	Y	Y	2	16x16 MAC	TQFP100	C8051F120DK
C8051F133	100	64 kB	8448	Y	32	2 UARTs, SMBus, SPI	5	6	±2%	10-bit, 8-ch., 100 ksps	-	-	Y	Y	2	16x16 MAC	TQFP64	C8051F120DK
C8051F124	50	128 kB	8448	Y	64	2 UARTs, SMBus, SPI	5	6	±2%	12-bit, 8-ch., 100 ksps	8-bit, 8-ch., 500 ksps	12-bit, 2-ch.	Y	Y	2	-	TQFP100	C8051F120DK
C8051F125	50	128 kB	8448	Y	32	2 UARTs, SMBus, SPI	5	6	±2%	12-bit, 8-ch., 100 ksps	8-bit, 8-ch., 500 ksps	12-bit, 2-ch.	Y	Y	2	-	TQFP64	C8051F120DK
C8051F126	50	128 kB	8448	Y	64	2 UARTs, SMBus, SPI	5	6	±2%	10-bit, 8-ch., 100 ksps	8-bit, 8-ch., 500 ksps	12-bit, 2-ch.	Y	Y	2	-	TQFP100	C8051F120DK
C8051F127	50	128 kB	8448	Y	32	2 UARTs, SMBus, SPI	5	6	±2%	10-bit, 8-ch., 100 ksps	8-bit, 8-ch., 500 ksps	12-bit, 2-ch.	Y	Y	2	-	TQFP64	C8051F120DK
C8051F350	50	8 kB	768	-	17	UART, SMBus, SPI	4	3	±2%	24-bit, 8-ch., 1 ksps	-	8-bit, 2-ch.	Y	Y	1	-	LQFP32	C8051F350DK
C8051F351	50	8 kB	768	-	17	UART, SMBus, SPI	4	3	±2%	24-bit, 8-ch., 1 ksps	-	8-bit, 2-ch.	Y	Y	1	-	QFN28	C8051F350DK
C8051F352	50	8 kB	768	-	17	UART, SMBus, SPI	4	3	±2%	16-bit, 8-ch., 1 ksps	-	8-bit, 2-ch.	Y	Y	1	-	LQFP32	C8051F350DK
C8051F353	50	8 kB	768	-	17	UART, SMBus, SPI	4	3	±2%	16-bit, 8-ch., 1 ksps	-	8-bit, 2-ch.	Y	Y	1	-	QFN28	C8051F350DK
C8051F020	25	64 kB	4352	Y	64	2 UARTs, SMBus, SPI	5	5	±20%	12-bit, 8-ch., 100 ksps	8-bit, 8-ch., 500 ksps	12-bit, 2-ch.	Y	Y	2	-	TQFP100	C8051F020DK
C8051F021	25	64 kB	4352	Y	32	2 UARTs, SMBus, SPI	5	5	±20%	12-bit, 8-ch., 100 ksps	8-bit, 8-ch., 500 ksps	12-bit, 2-ch.	Y	Y	2	-	TQFP64	C8051F020DK
C8051F022	25	64 kB	4352	Y	64	2 UARTs, SMBus, SPI	5	5	±20%	10-bit, 8-ch., 100 ksps	8-bit, 8-ch., 500 ksps	12-bit, 2-ch.	Y	Y	2	-	TQFP100	C8051F020DK
C8051F023	25	64 kB	4352	Y	32	2 UARTs, SMBus, SPI	5	5	±20%	10-bit, 8-ch., 100 ksps	8-bit, 8-ch., 500 ksps	12-bit, 2-ch.	Y	Y	2	-	TQFP64	C8051F020DK
C8051F064	25	64 kB	4352	Y	59	2 UARTs, SMBus, SPI	5	6	±2%	16-bit, 1-ch., 1 Msps	16-bit, 1-ch., 1 Msps	-	-	Y	3	DMA	TQFP100	C8051F060DK
C8051F065	25	64 kB	4352	-	24	2 UARTs, SMBus, SPI	5	6	±2%	16-bit, 1-ch., 1 Msps	16-bit, 1-ch., 1 Msps	-	-	Y	3	DMA	TQFP64	C8051F060DK
C8051F066	25	32 kB	4352	Y	59	2 UARTs, SMBus, SPI	5	6	±2%	16-bit, 1-ch., 1 Msps	16-bit, 1-ch., 1 Msps	-	-	Y	3	DMA	TQFP100	C8051F060DK
C8051F067	25	32 kB	4352	-	24	2 UARTs, SMBus, SPI	5	6	±2%	16-bit, 1-ch., 1 Msps	16-bit, 1-ch., 1 Msps	-	-	Y	3	DMA	TQFP64	C8051F060DK
C8051F005	25	32 kB	2304	-	32	UART, SMBus, SPI	4	5	±20%	12-bit, 8-ch., 100 ksps	-	12-bit, 2-ch.	Y	Y	2	-	TQFP64	C8051F005DK
C8051F006	25	32 kB	2304	-	16	UART, SMBus, SPI	4	5	±20%	12-bit, 8-ch., 100 ksps	-	12-bit, 2-ch.	Y	Y	2	-	TQFP48	C8051F005DK
C8051F007	25	32 kB	2304	-	8	UART, SMBus, SPI	4	5	±20%	12-bit, 4-ch., 100 ksps	-	12-bit, 2-ch.	Y	Y	1	-	LQFP32	C8051F005DK
C8051F015	25	32 kB	2304	-	32	UART, SMBus, SPI	4	5	±20%	10-bit, 8-ch., 100 ksps	-	12-bit, 2-ch.	Y	Y	2	-	TQFP64	C8051F005DK
C8051F016	25	32 kB	2304	-	16	UART, SMBus, SPI	4	5	±20%	10-bit, 8-ch., 100 ksps	-	12-bit, 2-ch.	Y	Y	2	-	TQFP48	C8051F005DK
C8051F017	25	32 kB	2304	-	8	UART, SMBus, SPI	4	5	±20%	10-bit, 4-ch., 100 ksps	-	12-bit, 2-ch.	Y	Y	1	-	LQFP32	C8051F005DK
C8051F018	25	16 kB	1280	-	32	UART, SMBus, SPI	4	5	±20%	10-bit, 8-ch., 100 ksps	-	-	Y	Y	2	-	TQFP64	C8051F005DK
C8051F019	25	16 kB	1280	-	16	UART, SMBus, SPI	4	5	±20%	10-bit, 8-ch., 100 ksps	-	-	Y	Y	2	-	TQFP48	C8051F005DK
C8051F000	20	32 kB	256	-	32	UART, SMBus, SPI	4	5	±20%	12-bit, 8-ch., 100 ksps	-	12-bit, 2-ch.	Y	Y	2	-	TQFP64	C8051F005DK
C8051F001	20	32 kB	256	-	16	UART, SMBus, SPI	4	5	±20%	12-bit, 8-ch., 100 ksps	-	12-bit, 2-ch.	Y	Y	2	-	TQFP48	C8051F005DK
C8051F002	20	32 kB	256	-	8	UART, SMBus, SPI	4	5	±20%	12-bit, 4-ch., 100 ksps	-	12-bit, 2-ch.	Y	Y	1	-	LQFP32	C8051F005DK
C8051F010	20	32 kB	256	-	32	UART, SMBus, SPI	4	5	±20%	10-bit, 8-ch., 100 ksps	-	12-bit, 2-ch.	Y	Y	2	-	TQFP64	C8051F005DK
C8051F011	20	32 kB	256	-	16	UART, SMBus, SPI	4	5	±20%	10-bit, 8-ch., 100 ksps	-	12-bit, 2-ch.	Y	Y	2	-	TQFP48	C8051F005DK
C8051F012	20	32 kB	256	-	8	UART, SMBus, SPI	4	5	±20%	10-bit, 4-ch., 100 ksps	-	12-bit, 2-ch.	Y	Y	1	-	LQFP32	C8051F005DK

## ToolStick Development Platform

The USB ToolStick platform is a fully contained evaluation and development system in a USB stick that demonstrates Silicon Labs' easy-to-use development tools. Using only a PC with a USB port, designers can fully experience the Silicon Labs software development environment in conjunction with the MCU on-chip debugging hardware that allows full, non-intrusive access to the CPU, peripherals and memory.

Buy online at [www.silabs.com/ToolStick](http://www.silabs.com/ToolStick)



# Small Form Factor Mixed-Signal MCUs

Part Number	MIPS (peak)	Flash (bytes)	RAM (bytes)	Digital Port I/O Pins	Serial Buses	Timers (16-bit)	PCA Chnls	Internal Osc	ADC	DAC	Temp Sensor	VREF	Comparators	Other	Package	Dev Kit
C8051F410	50	32 kB	2304	24	UART, SMBus, SPI	4	6	±2%	12-bit, 24-ch., 200 ksp/s	12-bit, 2-ch.	Y	Y	2	VREG, smaRTClock	LQFP32	C8051F410DK
C8051F411	50	32 kB	2304	20	UART, SMBus, SPI	4	6	±2%	12-bit, 20-ch., 200 ksp/s	12-bit, 2-ch.	Y	Y	2	VREG, smaRTClock	QFN28	C8051F410DK
C8051F412	50	16 kB	1280	24	UART, SMBus, SPI	4	6	±2%	12-bit, 24-ch., 200 ksp/s	12-bit, 2-ch.	Y	Y	2	VREG, smaRTClock	LQFP32	C8051F410DK
C8051F413	50	16 kB	1280	20	UART, SMBus, SPI	4	6	±2%	12-bit, 20-ch., 200 ksp/s	12-bit, 2-ch.	Y	Y	2	VREG, smaRTClock	QFN28	C8051F410DK
C8051F310	25	16 kB	1280	29	UART, SMBus, SPI	4	5	±2%	10-bit, 21-ch., 200 ksp/s	-	Y	-	2	-	LQFP32	C8051F310DK
C8051F311	25	16 kB	1280	25	UART, SMBus, SPI	4	5	±2%	10-bit, 17-ch., 200 ksp/s	-	Y	-	2	-	QFN28	C8051F310DK
C8051F316	25	16 kB	1280	21	UART, SMBus, SPI	4	5	±2%	10-bit, 16-ch., 200 ksp/s	-	Y	-	2	-	QFN24	C8051F310DK
C8051F317	25	16 kB	1280	21	UART, SMBus, SPI	4	5	±2%	-	-	Y	-	2	-	QFN24	C8051F310DK
C8051F206	25	8 kB	1280	32	UART, SPI	3	-	±20%	12-bit, 32-ch., 100 ksp/s	-	-	-	2	-	TQFP48	C8051F206DK
C8051F226	25	8 kB	1280	32	UART, SPI	3	-	±20%	8-bit, 32-ch., 100 ksp/s	-	-	-	2	-	TQFP48	C8051F226DK
C8051F236	25	8 kB	1280	32	UART, SPI	3	-	±20%	-	-	-	-	2	-	TQFP48	C8051F226DK
C8051F312	25	8 kB	1280	29	UART, SMBus, SPI	4	5	±2%	10-bit, 21-ch., 200 ksp/s	-	Y	-	2	-	LQFP32	C8051F310DK
C8051F313	25	8 kB	1280	25	UART, SMBus, SPI	4	5	±2%	10-bit, 17-ch., 200 ksp/s	-	Y	-	2	-	QFN28	C8051F310DK
C8051F314	25	8 kB	1280	29	UART, SMBus, SPI	4	5	±2%	-	-	Y	-	2	-	LQFP32	C8051F310DK
C8051F315	25	8 kB	1280	25	UART, SMBus, SPI	4	5	±2%	-	-	Y	-	2	-	QFN28	C8051F310DK
C8051F330	25	8 kB	768	17	UART, SMBus, SPI	4	3	±2%	10-bit, 16-ch., 200 ksp/s	10-bit, 1-ch.	Y	Y	1	-	QFN20	C8051F330DK
C8051F330D	25	8 kB	768	17	UART, SMBus, SPI	4	3	±2%	10-bit, 16-ch., 200 ksp/s	10-bit, 1-ch.	Y	Y	1	-	PDIP20	C8051F330DK
C8051F331	25	8 kB	768	17	UART, SMBus, SPI	4	3	±2%	-	-	-	-	1	-	QFN20	C8051F330DK
C8051F220	25	8 kB	256	32	UART, SPI	3	-	±20%	8-bit, 32-ch., 100 ksp/s	-	-	-	2	-	TQFP48	C8051F226DK
C8051F230	25	8 kB	256	32	UART, SPI	3	-	±20%	-	-	-	-	2	-	TQFP48	C8051F226DK
C8051F520	25	8 kB	256	6	LIN 2.0, SPI, UART	3	3	±0.5%	12-bit, 6-ch., 200 ksp/s	-	Y	Y	1	VREG, -40 to 125 °C	QFN10	C8051F530DK
C8051F521	25	8 kB	256	6	UART, SPI	3	3	±0.5%	12-bit, 6-ch., 200 ksp/s	-	Y	Y	1	VREG, -40 to 125 °C	QFN10	C8051F530DK
C8051F530	25	8 kB	256	16	LIN 2.0, SPI, UART	3	3	±0.5%	12-bit, 16-ch., 200 ksp/s	-	Y	Y	1	VREG, -40 to 125 °C	QFN20/TSSOP20	C8051F530DK
C8051F531	25	8 kB	256	16	UART, SPI	3	3	±0.5%	12-bit, 16-ch., 200 ksp/s	-	Y	Y	1	VREG, -40 to 125 °C	QFN20/TSSOP20	C8051F530DK
C8051F221	25	8 kB	256	22	UART, SPI	3	-	±20%	8-bit, 32-ch., 100 ksp/s	-	-	-	2	-	LQFP32	C8051F226DK
C8051F231	25	8 kB	256	22	UART, SPI	3	-	±20%	-	-	-	-	2	-	LQFP32	C8051F226DK
C8051F300	25	8 kB	256	8	UART, SMBus	3	3	±2%	8-bit, 8-ch., 500 ksp/s	-	Y	-	1	-	QFN11	C8051F300DK
C8051F301	25	8 kB	256	8	UART, SMBus	3	3	±2%	-	-	-	-	1	-	QFN11	C8051F300DK
C8051F302	25	8 kB	256	8	UART, SMBus	3	3	±20%	8-bit, 8-ch., 500 ksp/s	-	Y	-	1	-	QFN11	C8051F300DK
C8051F303	25	8 kB	256	8	UART, SMBus	3	3	±20%	-	-	-	-	1	-	QFN11	C8051F300DK
C8051F332	25	4 kB	768	17	UART, SMBus, SPI	4	3	±2%	10-bit, 16-ch., 200 ksp/s	-	Y	Y	1	-	QFN20	C8051F330DK
C8051F333	25	4 kB	768	17	UART, SMBus, SPI	4	3	±2%	-	-	-	-	1	-	QFN20	C8051F330DK
C8051F304	25	4 kB	256	8	UART, SMBus	3	3	±20%	-	-	-	-	1	-	QFN11	C8051F300DK
C8051F523	25	4 kB	256	6	LIN 2.0, SPI, UART	3	3	±0.5%	12-bit, 6-ch., 200 ksp/s	-	Y	Y	1	VREG, -40 to 125 °C	QFN10	C8051F530DK
C8051F524	25	4 kB	256	6	UART, SPI	3	3	±0.5%	12-bit, 6-ch., 200 ksp/s	-	Y	Y	1	VREG, -40 to 125 °C	QFN10	C8051F530DK
C8051F533	25	4 kB	256	16	LIN 2.0, SPI, UART	3	3	±0.5%	12-bit, 16-ch., 200 ksp/s	-	Y	Y	1	VREG, -40 to 125 °C	QFN20/TSSOP20	C8051F530DK
C8051F534	25	4 kB	256	16	UART, SPI	3	3	±0.5%	12-bit, 16-ch., 200 ksp/s	-	Y	Y	1	VREG, -40 to 125 °C	QFN20/TSSOP20	C8051F530DK
C8051F334	25	2 kB	768	17	UART, SMBus, SPI	4	3	±2%	10-bit, 16-ch., 200 ksp/s	-	Y	Y	1	-	QFN20	C8051F330DK
C8051F335	25	2 kB	768	17	UART, SMBus, SPI	4	3	±2%	-	-	-	-	1	-	QFN20	C8051F330DK
C8051F305	25	2 kB	256	8	UART, SMBus	3	3	±20%	-	-	Y	-	1	-	QFN11	C8051F300DK
C8051F526	25	2 kB	256	6	LIN 2.0, SPI, UART	3	3	±0.5%	12-bit, 6-ch., 200 ksp/s	-	Y	Y	1	VREG, -40 to 125 °C	QFN10	C8051F530DK
C8051F527	25	2 kB	256	6	UART, SPI	3	3	±0.5%	12-bit, 6-ch., 200 ksp/s	-	Y	Y	1	VREG, -40 to 125 °C	QFN10	C8051F530DK
C8051F536	25	2 kB	256	16	LIN 2.0, SPI, UART	3	3	±0.5%	12-bit, 16-ch., 200 ksp/s	-	Y	Y	1	VREG, -40 to 125 °C	QFN20/TSSOP20	C8051F530DK
C8051F537	25	2 kB	256	16	UART, SPI	3	3	±0.5%	12-bit, 16-ch., 200 ksp/s	-	Y	Y	1	VREG, -40 to 125 °C	QFN20/TSSOP20	C8051F530DK

# USB Mixed-Signal MCUs

Part Number	MIPS (peak)	Flash Memory	RAM (bytes)	Ext Mem I/F	Digital Port I/O Pins	Serial Buses	Timers (16-bit)	PCA Chnls	Internal Osc	ADC1	Temp Sensor	VREF	Comparators	Other	Package	Dev Kit
C8051F340	48	64 kB	5376	Y	40	USB 2.0, 2 x UART, SMBus, SPI	4	5	±1.5%	10-bit, 17-ch., 200 ksps	Y	Y	2	-	TQFP48	C8051F340DK
C8051F342	48	64 kB	5376	-	25	USB 2.0, UART, SMBus, SPI	4	5	±1.5%	10-bit, 17-ch., 200 ksps	Y	Y	2	-	LQFP32	C8051F340DK
C8051F341	48	32 kB	3328	Y	40	USB 2.0, 2 x UART, SMBus, SPI	4	5	±1.5%	10-bit, 17-ch., 200 ksps	Y	Y	2	-	TQFP48	C8051F340DK
C8051F343	48	32 kB	3328	-	25	USB 2.0, UART, SMBus, SPI	4	5	±1.5%	10-bit, 17-ch., 200 ksps	Y	Y	2	-	LQFP32	C8051F340DK
C8051F344	25	64 kB	5376	Y	40	USB 2.0, 2 x UART, SMBus, SPI	4	5	±1.5%	10-bit, 17-ch., 200 ksps	Y	Y	2	-	TQFP48	C8051F340DK
C8051F346	25	64 kB	5376	-	25	USB 2.0, UART, SMBus, SPI	4	5	±1.5%	10-bit, 17-ch., 200 ksps	Y	Y	2	-	LQFP32	C8051F340DK
C8051F345	25	32 kB	3328	Y	40	USB 2.0, 2 x UART, SMBus, SPI	4	5	±1.5%	10-bit, 17-ch., 200 ksps	Y	Y	2	-	TQFP48	C8051F340DK
C8051F347	25	32 kB	3328	-	25	USB 2.0, UART, SMBus, SPI	4	5	±1.5%	10-bit, 17-ch., 200 ksps	Y	Y	2	-	LQFP32	C8051F340DK
C8051F320	25	16 kB	2304	-	25	USB 2.0, UART, SMBus, SPI	4	5	±1.5%	10-bit, 17-ch., 200 ksps	Y	Y	2	-	LQFP32	C8051F320DK
C8051F321	25	16 kB	2304	-	21	USB 2.0, UART, SMBus, SPI	4	5	±1.5%	10-bit, 13-ch., 200 ksps	Y	Y	2	-	QFN28	C8051F320DK
C8051F326	25	16 kB	1536	-	15	USB 2.0, UART,	2	-	±1.5%	-	-	-	-	Separate I/O Supply Pin	QFN28	C8051F326DK
C8051F327	25	16 kB	1536	-	15	USB 2.0, UART,	2	-	±1.5%	-	-	-	-	Fixed I/O Supply	QFN28	C8051F326DK

## Embedded USB Made Easy

- Full range of single-chip USB MCUs
- Device and host drivers
- Extensive hardware and software reference designs

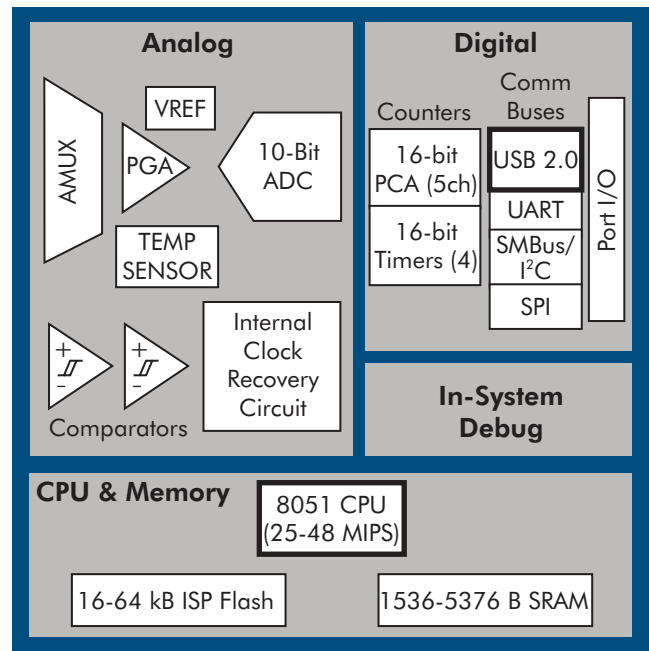
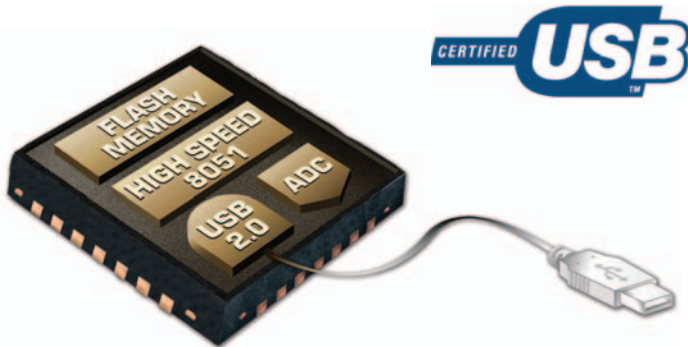

## USB to UART Bridge

Part Number	EEPROM (bytes)	RAM (bytes)	Digital Port I/O Pins	Serial Buses	Internal Osc	Other	Package	Eval Kit
CP2103	1024	1 kB	4	UART to USB Bridge	Y	Volt Reg, RS485, Split V <sub>DDIO</sub>	QFN28	CP2103EK
CP2102	1024	1 kB	-	UART to USB Bridge	Y	Volt Reg, host I/O	QFN28	CP2102EK
CP2101	512	1 kB	-	UART to USB Bridge	Y	Volt Reg	QFN28	CP2101EK



## Single-Chip USB to UART Solution

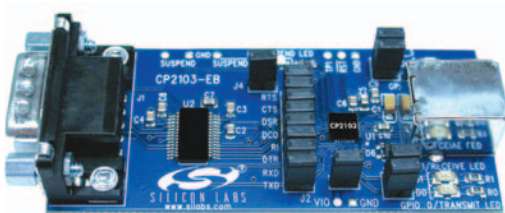

CP2103-EB

Easily update legacy RS-232 and RS-485 designs to USB. The CP210x single-chip solution provides a full-speed USB-to-UART bridge in a 5 x 5 mm package with no crystal, voltage regulator, EEPROM, or other external components required. System development is simplified by the Evaluation Kit, which includes a complete evaluation board and royalty-free device drivers.

Buy online at [www.silabs.com/USB](http://www.silabs.com/USB)

## 802.15.4/ZigBee™ Development Kits

Silicon Labs offers 802.15.4 and ZigBee development kits that allow customers to focus on application development rather than hardware selection. These kits include all the hardware and software needed to immediately begin developing 802.15.4 or ZigBee network solutions.

- Demonstration GUI
  - Graphical representation of 13 ZigBee topologies
  - Three demo applications to monitor data from any of the networked devices:
    - temperature, received signal strength indicator (RSSI) and thumbwheel (analog)
- 802.15.4 MAC-level application development
- ZigBee application development
- Silicon Labs Integrated Development Environment (IDE)

Buy online at [www.silabs.com/ZigBee](http://www.silabs.com/ZigBee)



**ZigBee-2.4-DK**

## Ethernet

Part Number	Flash	Parallel Host Interface	Parallel Host Interface Speed	Auto - Negotiation	Pre-Programmed MAC Address	RAM Size	LEDs	Temp Range	Transceiver	Package	Eval Kit	Dev Kit
CP2200	8 kB	8-bit non-multiplexed EMIF	30 Mbps	Y	Y	2 kB TX and 4 kB RX buffer	Separate link and activity	-40 to +85	Included	TQFP48	CP2201EK	ETHERNETDK
CP2201	8 kB	8-bit multiplexed EMIF	25 Mbps	Y	Y	2 kB TX and 4 kB RX buffer	Combined link and activity	-40 to +85	Included	QFN28	CP2201EK	ETHERNETDK

## PoE-Voice-EB



## Power over Ethernet Voice Reference Design

This reference design includes the PoE-VOICE-EB Reference Design Board which contains an IEEE 802.3af compliant Power over Ethernet circuit, 8 kHz voice/speech sampling system and an IEEE 802.3 embedded Ethernet connection. The board provides a hardware platform for evaluating and developing software for embedded systems that use the C8051F340 as the main controller, the CP2201 as the Ethernet controller and the Si3400 as the PoE controller. The reference design software uses the TCP/IP Configuration Wizard, which generates starter firmware based on the industry standard CMX™ Micronet Stack.

Buy online at [www.silabs.com/Ethernet](http://www.silabs.com/Ethernet)

## CP2120 SPI-I<sup>2</sup>C Bridge and GPIO Port Expander

The CP2120 allows an SPI master to communicate as an I<sup>2</sup>C master device. The chip includes a 4-wire slave SPI bus, bridge control logic, a bi-directional I<sup>2</sup>C bus interface and 8 general purpose input/output pins. The CP2120 Evaluation Kit demonstrates the SPI-I<sup>2</sup>C fixed functionality and requires absolutely no code development.

Buy online at [www.silabs.com/CP2120](http://www.silabs.com/CP2120)

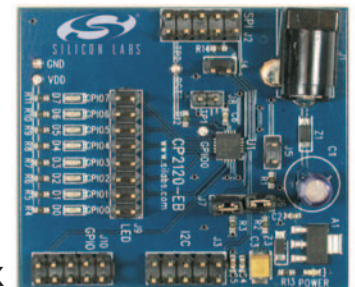

**CP2120EK**

## CAN Mixed-Signal MCUs

Part Number	MIPS (peak)	Flash (bytes)	RAM (bytes)	Ext Mem I/F	Digital Port I/O Pins	Serial Buses	Timers (16-bit)	PCA Chnls	Internal Osc	ADC1	ADC2	DAC	Temp Sensor	VREF	Comparators	Other	Package	Dev Kit
C8051F040	25	64 kB	4352	Y	64	CAN2.0B, 2 UARTs, SMBus, SPI	5	6	±2%	12-bit, 13-ch., 100 ksp/s	8-bit, 8-ch., 500 ksp/s	12-bit, 2-ch.	Y	Y	3	±60 V PGA	TQFP100	C8051F040DK
C8051F041	25	64 kB	4352	Y	32	CAN2.0B, 2 UARTs, SMBus, SPI	5	6	±2%	12-bit, 13-ch., 100 ksp/s	8-bit, 8-ch., 500 ksp/s	12-bit, 2-ch.	Y	Y	3	±60 V PGA	TQFP64	C8051F040DK
C8051F042	25	64 kB	4352	Y	64	CAN2.0B, 2 UARTs, SMBus, SPI	5	6	±2%	10-bit, 13-ch., 100 ksp/s	8-bit, 8-ch., 500 ksp/s	12-bit, 2-ch.	Y	Y	3	±60 V PGA	TQFP100	C8051F040DK
C8051F043	25	64 kB	4352	Y	32	CAN2.0B, 2 UARTs, SMBus, SPI	5	6	±2%	10-bit, 13-ch., 100 ksp/s	8-bit, 8-ch., 500 ksp/s	12-bit, 2-ch.	Y	Y	3	±60 V PGA	TQFP64	C8051F040DK
C8051F044	25	64 kB	4352	Y	64	CAN2.0B, 2 UARTs, SMBus, SPI	5	6	±2%	10-bit, 13-ch., 100 ksp/s	-	-	Y	Y	3	±60 V PGA	TQFP100	C8051F040DK
C8051F045	25	64 kB	4352	Y	32	CAN2.0B, 2 UARTs, SMBus, SPI	5	6	±2%	10-bit, 13-ch., 100 ksp/s	-	-	Y	Y	3	±60 V PGA	TQFP64	C8051F040DK
C8051F060	25	64 kB	4352	Y	59	CAN2.0B, 2 UARTs, SMBus, SPI	5	6	±2%	16-bit, 1-ch., 1 Msps	16-bit, 1-ch., 1 Msps	12-bit, 2-ch.	Y	Y	3	10-bit, 8-ch., 200 ksp/s	TQFP100	C8051F060DK
C8051F061	25	64 kB	4352	-	24	CAN2.0B, 2 UARTs, SMBus, SPI	5	6	±2%	16-bit, 1-ch., 1 Msps	16-bit, 1-ch., 1 Msps	12-bit, 2-ch.	Y	Y	3	10-bit, 8-ch., 200 ksp/s	TQFP64	C8051F060DK
C8051F062	25	64 kB	4352	Y	59	CAN2.0B, 2 UARTs, SMBus, SPI	5	6	±2%	16-bit, 1-ch., 1 Msps	16-bit, 1-ch., 1 Msps	12-bit, 2-ch.	Y	Y	3	10-bit, 8-ch., 200 ksp/s	TQFP100	C8051F060DK
C8051F063	25	64 kB	4352	-	24	CAN2.0B, 2 UARTs, SMBus, SPI	5	6	±2%	16-bit, 1-ch., 1 Msps	16-bit, 1-ch., 1 Msps	12-bit, 2-ch.	Y	Y	3	10-bit, 8-ch., 200 ksp/s	TQFP64	C8051F060DK
C8051F046	25	32 kB	4352	Y	64	CAN2.0B, 2 UARTs, SMBus, SPI	5	6	±2%	10-bit, 13-ch., 100 ksp/s	-	-	Y	Y	3	±60 V PGA	TQFP100	C8051F040DK
C8051F047	25	32 kB	4352	Y	32	CAN2.0B, 2 UARTs, SMBus, SPI	5	6	±2%	10-bit, 13-ch., 100 ksp/s	-	-	Y	Y	3	±60 V PGA	TQFP64	C8051F040DK

# Microcontroller Development Tools

## Development Kits

Complete development/prototyping system includes the following:

- Prototyping/demonstration board
- USB adapter for in-system programming and debugging
- Silicon Laboratories IDE
- MCU configuration wizard

Buy online at [www.silabs.com/DevKits](http://www.silabs.com/DevKits)

## Integrated Development Environment

4 kB C compiler included

Source code editor

Project manager

Keil 8051 macro assembler and linker

Flash programmer

Supports full-speed, non-intrusive, in-circuit debug logic

Source-level debug

Variable watch window

Real-time breakpoints

Conditional memory watchpoints

Memory and register inspect/modify

Supports third-party development tools

Single-step and animated execution modes



## Third Party Tool Support

A broad range of third-party compilers and development tools are available, including a free Small Device C Compiler (SDCC) supported by App Note 198, "Integrating SDCC 8051 Tools into the Silicon Labs IDE." Flash programming and source-level debug of OMF-51 object files is fully supported.

## Design Support at [www.silabs.com/MCU](http://www.silabs.com/MCU)

Silicon Laboratories' Reference Designs, Application Notes and source code examples address a wide range of applications and markets. Visit our website at [www.silabs.com/MCU](http://www.silabs.com/MCU) for complete access to all of our design resources.

## Product Support at [www.silabs.com/support](http://www.silabs.com/support)

💡 MCU Knowledge Base: answers to common technical questions about the MCU product line and product use.

MCU User's Forum: where C8051F MCU users can share experiences and technical questions with other users.

Microcontroller support email:

Americas: [mcuapps@silabs.com](mailto:mcuapps@silabs.com)

Europe and Asia: [eumcuapps@silabs.com](mailto:eumcuapps@silabs.com)

Development Kit or IDE support email: [mcutools@silabs.com](mailto:mcutools@silabs.com)



**Pricing and availability:**  
[www.silabs.com/sales](http://www.silabs.com/sales)

### Corporate Headquarters

400 West Cesar Chavez  
Austin, TX 78701  
512.416.8500  
877.444.3032 (toll free)  
Fax: 512.416.9669