

Supply & Charging

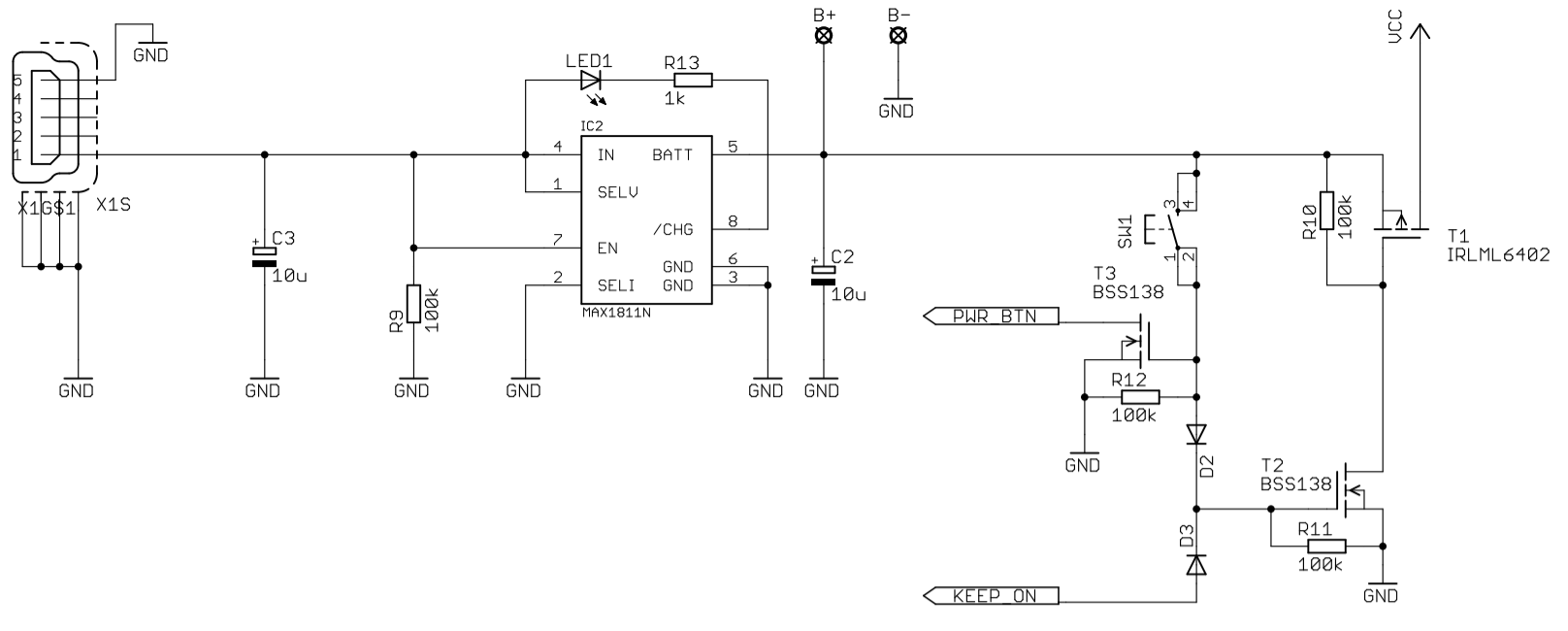

Measuring

Voltmeter
 $U_p = 1.201V$
 $CP = [-30U...+30U] \rightarrow U_a = [2,45U...0,05U]$
 DNP R27, R28
 R29 is optional (zero display on open inputs)

Ammeter
 $U_p = 0.139V$
 $CP = [-0,15U...+0,15U] \rightarrow U_a = [2,45U...0,05U]$
 DNP R29

Resistors
 R14-R21: 0.1%
 R27, R28: 1%
 all others: 5%
 Values are for Voltmeter,
 in brackets for Ammeter

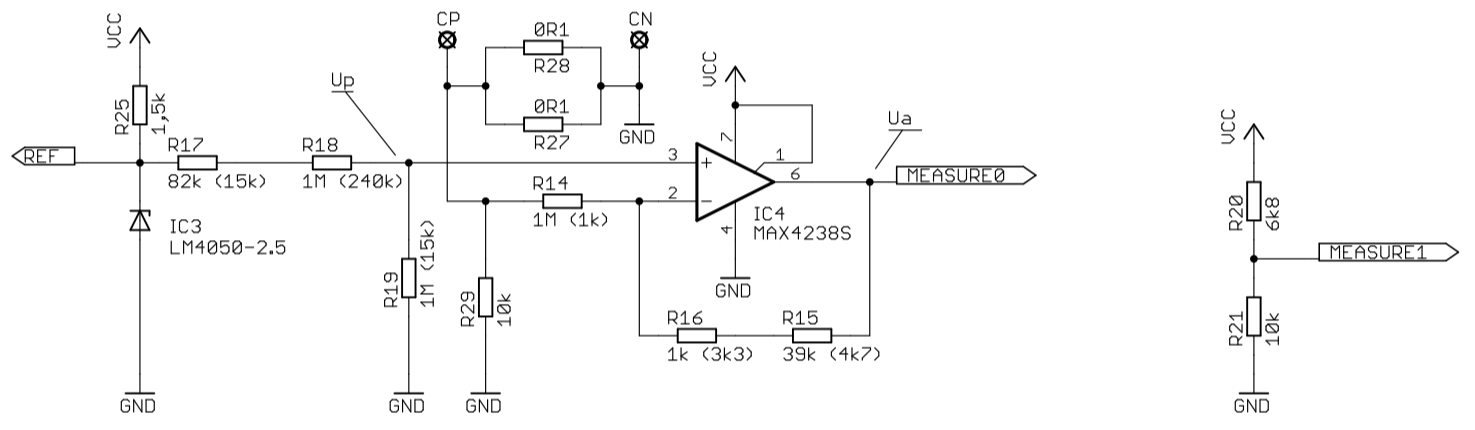

µC

