

ESPRESSIF SMART CONNECTIVITY PLATFORM: ESP8266EX

Disclaimer and Copyright Notice

Information in this document, including URL references, is subject to change without notice.

THIS DOCUMENT IS PROVIDED "AS IS" WITH NO WARRANTIES WHATSOEVER, INCLUDING ANY WARRANTY OF MERCHANTABILITY, NONINFRINGEMENT, FITNESS FOR ANY PARTICULAR PURPOSE, OR ANY WARRANTY OTHERWISE ARISING OUT OF ANY PROPOSAL, SPECIFICATION OR SAMPLE. All liability, including liability for infringement of any proprietary rights, relating to use of information in this document is disclaimed. No licenses express or implied, by estoppel or otherwise, to any intellectual property rights are granted herein.

The Wi-Fi Alliance Member Logo is a trademark of the Wi-Fi Alliance.

All trade names, trademarks and registered trademarks mentioned in this document are property of their respective owners, and are hereby acknowledged.

Copyright © 2013 Espressif Systems Inc. All rights reserved.

Table of Contents

1	INTRODUCTION	4
2	TECHNOLOGY OVERVIEW	5
3	FEATURES	6
4	APPLICATION DIAGRAM	7
5	ULTRA LOW POWER TECHNOLOGY	8
5.1	HIGHEST LEVEL OF INTEGRATION	ERROR! BOOKMARK NOT DEFINED.
6	ESP8266EX APPLICATIONS	9
7	SPECIFICATIONS	10
7.1	CURRENT CONSUMPTION	10
7.2	RECEIVER SENSITIVITY	11
8	CPU, MEMORY AND INTERFACES	12
8.1	CPU.....	12
8.2	MEMORY CONTROLLER	12
8.3	AHB AND AHB BLOCKS.....	12
8.4	INTERFACES	12
8.4.1	<i>Master SI / SPI Control (Optional)</i>	13
8.4.2	<i>General Purpose IO</i>	14
8.4.3	<i>Real Time Clock IO (EXT_LFC)</i>	14
8.4.4	<i>Digital IO Pads</i>	14
9	FIRMWARE & SOFTWARE DEVELOPMENT KIT	16
9.1	FEATURES	16
10	POWER MANAGEMENT	18
11	CLOCK MANAGEMENT	19
11.1	HIGH FREQUENCY CLOCK.....	19
11.2	EXTERNAL REFERENCE REQUIREMENTS	20
12	RADIO	21
12.1	CHANNEL FREQUENCIES	21
12.2	2.4GHZ RECEIVER.....	21
12.3	2.4GHZ TRANSMITTER	21
12.4	CLOCK GENERATOR	22

1 Introduction

Espressif Systems’ Smart Connectivity Platform (ESCP) is a set of high performance, high integration wireless SOCs, designed for space and power constrained mobile platform designers. It provides unsurpassed ability to embed Wi-Fi capabilities within other systems, or to function as a standalone application, with the lowest cost, and minimal space requirement.

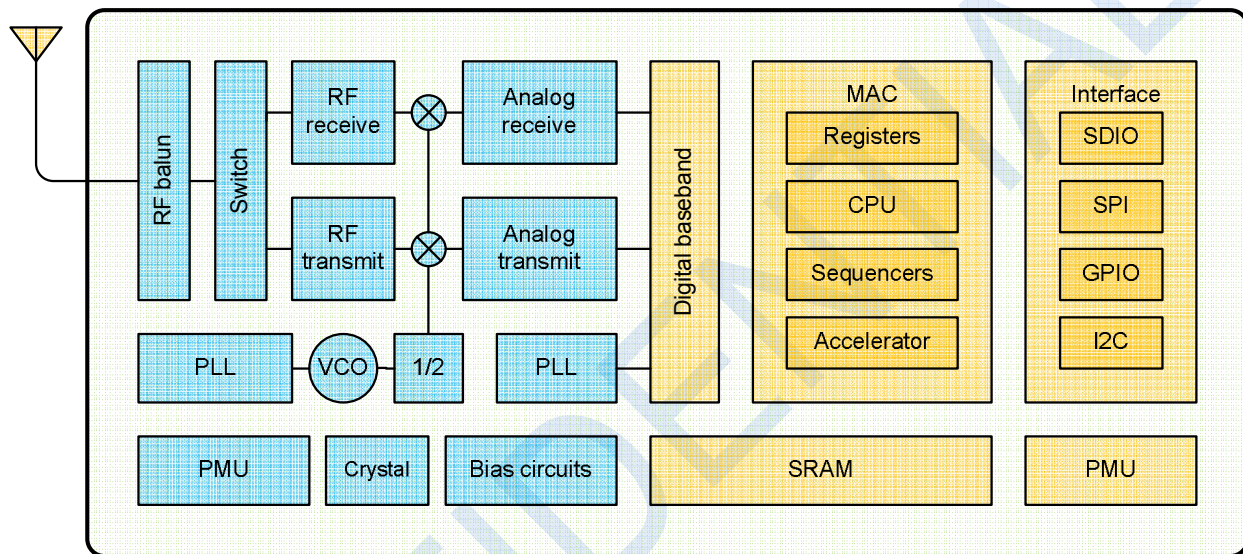

Figure 1: ESP8266EX Block Diagram

2 Technology Overview

ESP8266EX offers a complete and self-contained Wi-Fi networking solution; it can be used to host the application or to offload Wi-Fi networking functions from another application processor.

When ESP8266EX hosts the application, it boots up directly from an external flash. It has integrated cache to improve the performance of the system in such applications.

Alternately, serving as a Wi-Fi adapter, wireless internet access can be added to any microcontroller-based design with simple connectivity through UART interface or the CPU AHB bridge interface.

ESP8266EX is among the most integrated WiFi chip in the industry; it integrates the antenna switches, RF balun, power amplifier, low noise receive amplifier, filters, power management modules, it requires minimal external circuitry, and the entire solution, including front-end module, is designed to occupy minimal PCB area.

ESP8266EX also integrates an enhanced version of Tensilica's L106 Diamond series 32-bit processor, with on-chip SRAM, besides the Wi-Fi functionalities. ESP8266EX is often integrated with external sensors and other application specific devices through its GPIOs; codes for such applications are provided in examples in the SDK.

Sophisticated system-level features include fast sleep/wake context switching for energy-efficient VoIP, adaptive radio biasing for low-power operation, advance signal processing, and spur cancellation and radio co-existence features for common cellular, Bluetooth, DDR, LVDS, LCD interference mitigation.

3 Features

- 802.11 b/g/n protocol
- Wi-Fi Direct (P2P), soft-AP
- Integrated TCP/IP protocol stack
- Integrated TR switch, balun, LNA, power amplifier and matching network
- Integrated PLL, regulators, and power management units
- +20.5dBm output power in 802.11b mode
- Supports antenna diversity
- Power down leakage current of < 10uA
- Integrated low power 32-bit MCU
- SDIO 2.0, SPI, UART
- STBC, 1x1 MIMO, 2x1 MIMO
- A-MPDU & A-MSDU aggregation & 0.4 μ s guard interval
- Wake up and transmit packets in < 22ms
- Standby power consumption of < 1.0mW (DTIM3)

4 Application Diagram

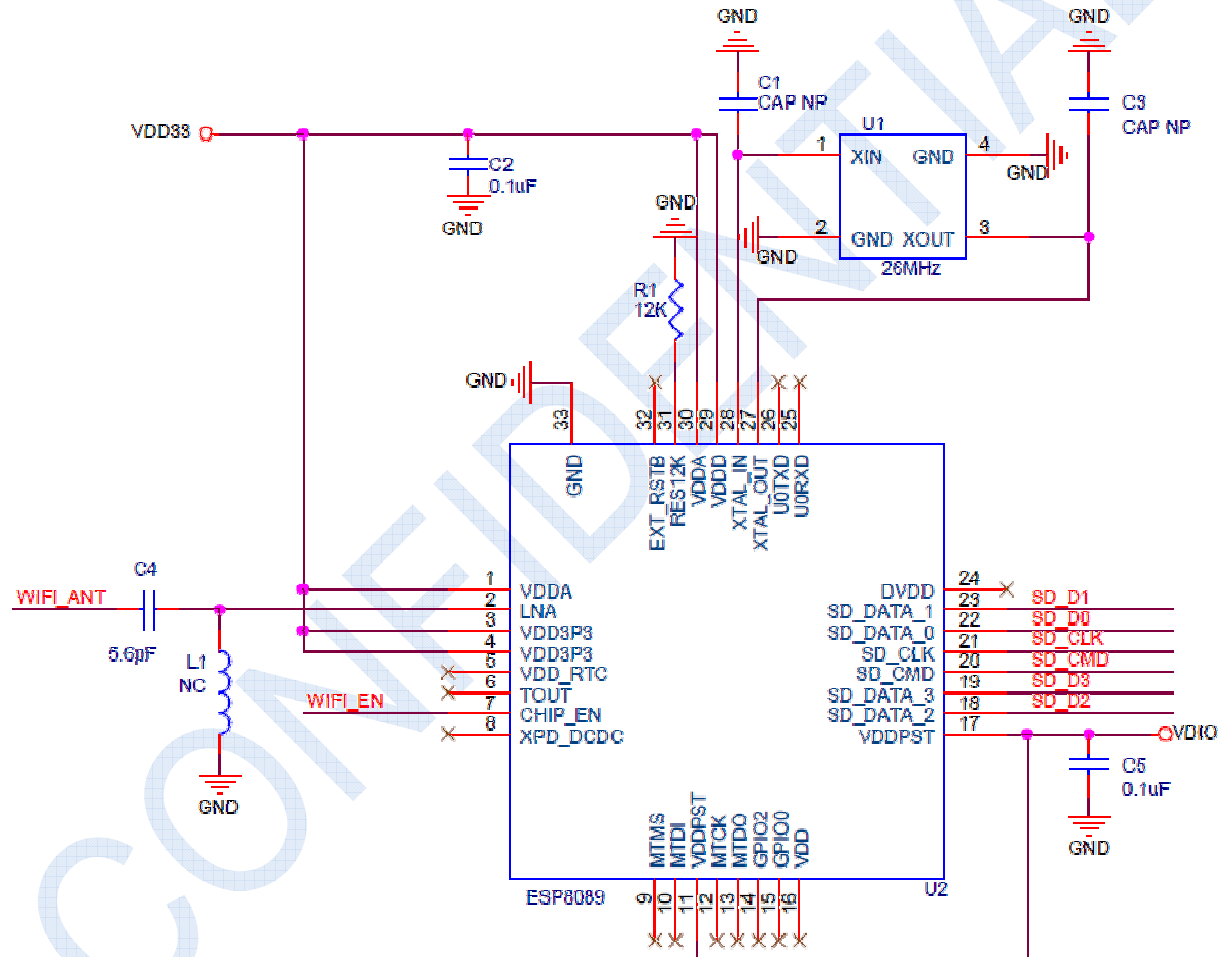

5 Ultra Low Power Technology

ESP8266EX has been designed for mobile, wearable electronics and Internet of Things applications with the aim of achieving the lowest power consumption with a combination of several proprietary techniques. The power saving architecture operates mainly in 3 modes: active mode, sleep mode and deep sleep mode.

By using advance power management techniques and logic to power-down functions not required and to control switching between sleep and active modes, ESP8266EX consumes about than 60uA in deep sleep mode (with RTC clock still running) and less than 1.0mA (DTIM=3) or less than 0.5mA (DTIM=10) to stay connected to the access point.

When in sleep mode, only the calibrated real-time clock and watchdog remains active. The real-time clock can be programmed to wake up the ESP8266EX at any required interval.

The ESP8266EX can be programmed to wake up when a specified condition is detected. This minimal wake-up time feature of the ESP8266EX can be utilized by mobile device SOCs, allowing them to remain in the low-power standby mode until Wi-Fi is needed.

In order to satisfy the power demand of mobile and wearable electronics, ESP8266EX can be programmed to reduce the output power of the PA to fit various application profiles, by trading off range for power consumption.

5.1 Integration of External Components

By integrating the costliest components such as power management unit, TR switch, RF balun, high power PA capable of delivering +25dBm (peak), ESP8266EX ensures that the BOM cost is the lowest possible, and ease of integration into any system.

With ESP8266, the only external BOM are resistors, capacitors, and crystal. For cellphone compatibility a SAW filter may be required.

6 ESP8266EX Applications

- Smart power plugs
- Home automation
- Mesh network
- Industrial wireless control
- Baby monitors
- IP Cameras
- Sensor networks
- Wearable electronics
- Wi-Fi location-aware devices
- Security ID tags
- Wi-Fi position system beacons

CONFIDENTIAL

7 Specifications

7.1 Current Consumption

The following current consumption is based on 3.3V supply, and 25°C ambient, using internal regulators. Measurements are done at antenna port without SAW filter. All the transmitter's measurements are based on 90% duty cycle, continuous transmit mode.

Mode	Min	Typ	Max	Unit
Transmit 802.11b, CCK 1Mbps, POUT=+19.5dBm		215		mA
Transmit 802.11b, CCK 11Mbps, POUT=+18.5dBm		197		mA
Transmit 802.11g, OFDM 54Mbps, POUT =+16dBm		145		mA
Transmit 802.11n, MCS7, POUT=+14dBm		135		mA
Receive 802.11b, packet length=1024 byte, -80dBm		60		mA
Receive 802.11g, packet length=1024 byte, -70dBm		60		mA
Receive 802.11n, packet length=1024 byte, -65dBm		62		mA
Standby		0.9		mA
Deep sleep (RTC)		60		uA
Power save mode DTIM 1		1.2		mA
Power save mode DTIM 3		0.86		mA
Sleep mode (Memory retention)		0.31		mA
Total shutdown		1		uA

7.2 Receiver Sensitivity

The following are measured under room temperature conditions with 3.3V and 1.1V power supplies.

Description	Min	Typical	Max	Unit
Input frequency	2412		2484	MHz
Input impedance		50		Ω
Input reflection			-10	dB
Output power of PA for 72.2Mbps	15.5	16.5	17.5	dBm
Output power of PA for 11b mode	19.5	20.5	21.5	dBm
Sensitivity				
CCK, 1Mbps		-98		dBm
CCK, 11Mbps		-91		dBm
6Mbps (1/2 BPSK)		-93		dBm
54Mbps (3/4 64-QAM)		-75		dBm
HT20, MCS7 (65Mbps, 72.2Mbps)		-71		dBm
Adjacent Channel Rejection				
OFDM, 6Mbps		37		dB
OFDM, 54Mbps		21		dB
HT20, MCS0		37		dB
HT20, MCS7		20		dB

8 CPU, Memory and Interfaces

8.1 CPU

This chip embeds a low power Micro 32-bit CPU, with 16-bit thumb mode. This CPU can be interfaced using:

- code RAM/ROM interface (iBus) that goes to the memory controller, that can also be used to access external flash memory,
- data RAM interface (dBus), that also goes to the memory controller
- AHB interface, for register access, and
- JTAG interface for debugging

8.2 Memory Controller

The memory controller contains ROM, and SRAM. It is accessed by the CPU using the iBus, dBus and AHB interface. Any of these interfaces can request access to the ROM or RAM modules, and the memory controller arbiters serve these 3 interfaces on a first-come-first-serve basis.

8.3 AHB and AHB Blocks

The AHB blocks performs the function of an arbiter, controls the AHB interfaces from the MAC, SDIO (host) and CPU. Depending on the address, the AHB data requests can go into one of the two slaves:

- APB block, or
- flash controller (usually for standalone applications).

Data requests to the memory controller are usually high speed requests, and requests to the APB block are usually register access.

The APB block acts as a decoder. It is meant only for access to programmable registers within ESP8266's main blocks. Depending on the address, the APB request can go to the radio, SI/SPI, SDIO (host), GPIO, UART, real-time clock (RTC), MAC or digital baseband.

8.4 Interfaces

The ESP8266EX contains several analog and digital interfaces described in the following sections.

8.4.1 Master SI / SPI Control (Optional)

The master serial interface (SI) can operate in two, three or four-wire bus configurations to control the EEPROM or other I2C/SPI devices. Multiple I2C devices with different device addresses are supported by sharing the 2-wire bus.

Multiple SPI devices are supported by sharing the clock and data signals, using separate software controlled GPIO pins as chip selects.

The SPI can be used for controlling external devices such as serial flash memories, audio CODECs, or other slave devices. It is set up as a standard master SPI device with 3 different enable pins:

- SPI_EN0,
- SPI_EN1,
- SPI_EN2.

Both SPI master and SPI slave are supported with the latter being used as a host interface.

SPI_EN0 is used as an enable signal to an external serial flash memory for downloading patch code and/or MIB-data to the baseband in an embedded application. In a host based application, patch code and MIB-data can alternatively be downloaded via the host interface. This pin is active low and should be left open if not used.

SPI_EN1 is usually used for a user application, e.g. to control an external audio codec or sensor ADC, in an embedded application. This pin is active low and should be left open if not used.

SPI_EN2 usually controls an EEPROM to store individual data, such as MIB information, MAC address, and calibration data, or for general use. This pin is active low and should be left open if not used.

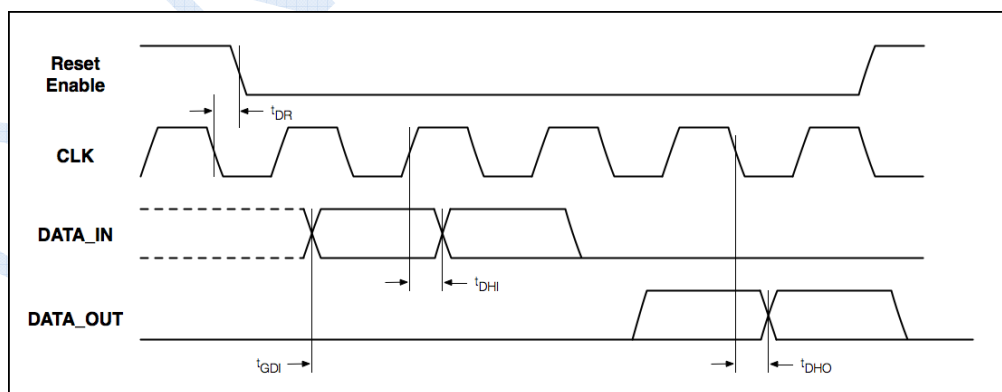

Figure 2: SPI timing characteristics

8.4.2 General Purpose IO

There are up to 16 GPIO pins. They can be assigned to various functions by the firmware. Each GPIO can be configured with internal pull-up/down, input available for sampling by a software register, input triggering an edge or level CPU interrupt, input triggering a level wakeup interrupt, open-drain or push-pull output driver, or output source from a software register, or a sigma-delta PWM DAC.

These pins are multiplexed with other functions such as host interface, UART, SI, Bluetooth coexistence, etc.

8.4.3 Real Time Clock IO (EXT_LFC)

If a 32.768 kHz LFC clock is available, it can be connected to **EXT_LFC**. If no clock is available on this pin, the internal LFC will be used. If an **EXT_LFC** is available, the selection of LFC source, internal LFC or **EXT_LFC** can be done by a strapping pin.

8.4.4 Digital IO Pads

The digital IO pads are bidirectional, non-inverting and tri-state. It includes input and an output buffer with tristate control inputs. Besides this, for low power operations, the IO can also be set to hold. For instance, when we power down the chip, all output enable signals can be set to hold low.

Optional hold functionality can be built into the IO if requested. When the IO is not driven by the internal or external circuitry, the hold functionality can be used to hold the state to the last used state.

The hold functionality introduces some positive feedback into the pad. Hence, the external driver that drives the pad must be stronger than the positive feedback. The required drive strength is however small – in the range of 5uA.

Parameter	Symbol	Min	Max	Unit
Input low voltage	V_{IL}	-0.3	$0.25 \times V_{IO}$	V
Input high voltage	V_{IH}	$0.75 \times V_{IO}$	3.6	V
Input leakage current	I_{IL}		50	nA
Output low voltage	V_{OL}		$0.1 \times V_{IO}$	V
Output high voltage	V_{OH}	$0.8 \times V_{IO}$		V
Input pin capacitance	C_{pad}		2	pF

VDDIO	V_{IO}	1.7	3.6	V
Maximum drive capability	I_{MAX}		12	mA
Temperature	T_{amb}	-20	100	°C

All digital IO pins are protected from over-voltage with a snap-back circuit connected between the pad and ground. The snap back voltage is typically about 6V, and the holding voltage is 5.8V. This provides protection from over-voltages and ESD. The output devices are also protected from reversed voltages with diodes.

8.5 Analog ADC

ESP8266EX also integrates a generic purpose 10-bit analog ADC. The ADC range is from 0V to 1.0V. It is typically used to measure the voltages from the sensor or battery status. The ADC cannot be used when the chip is transmitting. Otherwise the voltage may be inaccurate.

9 Firmware & Software Development Kit

The application and firmware is executed in on-chip ROM and SRAM, which loads the instructions during wake-up, through the SDIO interface, from the external flash.

The firmware implements TCP/IP, the full 802.11 b/g/n/e/i WLAN MAC protocol and Wi-Fi Direct specification. It supports not only basic service set (BSS) operations under the distributed control function (DCF) but also P2P group operation compliant with the latest Wi-Fi P2P protocol. Low level protocol functions are handled automatically by ESP8266:

- RTS/CTS,
- acknowledgement,
- fragmentation and defragmentation,
- aggregation,
- frame encapsulation (802.11h/RFC 1042),
- automatic beacon monitoring / scanning, and
- P2P Wi-Fi direct,

Passive or active scanning, as well as P2P discovery procedure is performed autonomously once initiated by the appropriate command. Power management is handled with minimum host interaction to minimize active duty period.

9.1 Features

The SDK includes the following library functions:

- 802.11 b/g/n/d/e/i/k/r support;
- Wi-Fi Direct (P2P) support:
- P2P Discovery, P2P Group Owner mode, P2P Power Management
- Infrastructure BSS Station mode / P2P mode / softAP mode support;
- Hardware accelerators for CCMP (CBC-MAC, counter mode), TKIP (MIC, RC4), WAPI (SMS4), WEP (RC4), CRC;
- WPA/WPA2 PSK, and WPS driver;
- Additional 802.11i security features such as pre-authentication, and TSN;
- Open Interface for various upper layer authentication schemes over EAP such as TLS, PEAP, LEAP, SIM, AKA, or customer specific;
- 802.11n support (2.4GHz / 5GHz);
- Supports MIMO 1×1 and 2×1, STBC, A-MPDU and A-MSDU aggregation and 0.4μs guard interval;

- WMM power save U-APSD;
- Multiple queue management to fully utilize traffic prioritization defined by 802.11e standard;
- UMA compliant and certified;
- 802.1h/RFC1042 frame encapsulation;
- Scattered DMA for optimal CPU off load on Zero Copy data transfer operations;
- Antenna diversity and selection (software managed hardware);
- Clock/power gating combined with 802.11-compliant power management dynamically adapted to current connection condition providing minimal power consumption;
- Adaptive rate fallback algorithm sets the optimum transmission rate and Tx power based on actual SNR and packet loss information;
- Automatic retransmission and response on MAC to avoid packet discarding on slow host environment;
- Seamless roaming support;
- Configurable packet traffic arbitration (PTA) with dedicated slave processor based design provides flexible and exact timing Bluetooth co-existence support for a wide range of Bluetooth Chip vendors;
- Dual and single antenna Bluetooth co-existence support with optional simultaneous receive (Wi-Fi/Bluetooth) capability.

10 Power Management

The chip can be put into the following states:

- **OFF:** CHIP_PD pin is low. The RTC is disabled. All registers are cleared.
- **DEEP_SLEEP:** Only RTC is powered on – the rest of the chip is powered off. Recovery memory of RTC can keep basic Wi-Fi connecting information.
- **SLEEP:** Only the RTC is operating. The crystal oscillator is disabled. Any wakeup events (MAC, host, RTC timer, external interrupts) will put the chip into the WAKEUP state.
- **WAKEUP:** In this state, the system goes from the sleep states to the PWR state. The crystal oscillator and PLLs are enabled.
- **ON:** the high speed clock is operational and sent to each block enabled by the clock control register. Lower level clock gating is implemented at the block level, including the CPU, which can be gated off using the WAITI instruction, while the system is on.

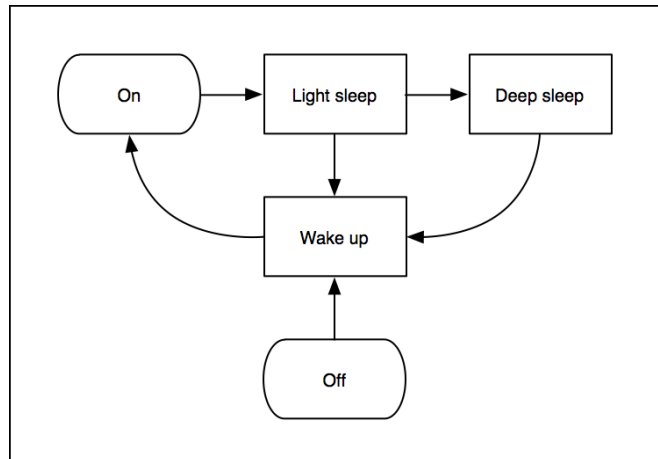

11 Clock Management

11.1 High Frequency Clock

The high frequency clock on ESP8266EX is used to drive both transmit and receive mixers. This clock is generated from the internal crystal oscillator and an external crystal. The crystal frequency can range from 26MHz to 52MHz.

While internal calibration of the crystal oscillator ensures that a wide range of crystals can be used, in general, the quality of the crystal is still a factor to consider, to have reasonable phase noise that is required for good performance. When the crystal selected is sub-optimal due to large frequency drifts or poor Q-factor, the maximum throughput and sensitivity of the Wi-Fi system is degraded. Please refer to the application notes on how the frequency offset can be measured.

Parameter	Symbol	Min	Max	Unit
Frequency	FXO	26	52	MHz
Loading capacitance	CL		32	pF
Motional capacitance	CM	2	5	pF
Series resistance	RS	0	65	Ω
Frequency tolerance	Δ FXO	-15	15	ppm
Frequency vs temperature (-25°C ~ 75°C)	Δ FXO,Temp	-15	15	ppm

11.2 External Reference Requirements

For an externally generated clock, the frequency can range from 26MHz to 52MHz can be used. For good performance of the radio, the following characteristics are expected of the clock:

Parameter	Symbol	Min	Max	Unit
Clock amplitude	V_{XO}	0.2	1	V _{pp}
External clock accuracy	$\Delta F_{XO,EXT}$	-15	15	ppm
Phase noise @1kHz offset, 40MHz clock			-120	dBc/Hz
Phase noise @10kHz offset, 40MHz clock			-130	dBc/Hz
Phase noise @100kHz offset, 40MHz clock			-138	dBc/Hz

12 Radio

The ESP8266EX radio consists of the following main blocks:

- 2.4GHz receiver
- 2.4GHz transmitter
- High speed clock generators and crystal oscillator
- Real time clock
- Bias and regulators
- Power management

12.1 Channel Frequencies

The RF transceiver supports the following channels according to the IEEE802.11bgn standards.

Channel No	Frequency (MHz)	Channel No	Frequency (MHz)
1	2412	8	2447
2	2417	9	2452
3	2422	10	2457
4	2427	11	2462
5	2432	12	2467
6	2437	13	2472
7	2442	14	2484

12.2 2.4GHz Receiver

The 2.4GHz receiver downconverts the RF signal to quadrature baseband signals and converts them to the digital domain with 2 high resolution high speed ADCs. To adapt to varying signal channel conditions, RF filters, automatic gain control, DC offset cancellation circuits and baseband filters are integrated within ESP8266EX.

12.3 2.4GHz Transmitter

The 2.4GHz transmitter upconverts the quadrature baseband signals to 2.4GHz, and drives the antenna with a high powered CMOS power amplifier. The use of digital calibration further

improves the linearity of the power amplifier, enabling a state of art performance of delivering +20.5dBm average power for 802.11b transmission and +16dBm for 802.11n transmission.

Additional calibrations are integrated to cancel any imperfections of the radio, such as:

- carrier leakage,
- I/Q phase matching, and
- baseband nonlinearities

This reduces the amount of time required and test equipment required for production testing.

12.4 Clock Generator

The clock generator generates quadrature 2.4GHz clock signals for the receiver and transmitter. All components of the clock generator are integrated on-chip, including:

- inductor,
- varactor, and
- loop filter.

The clock generator has built-in calibration and self test circuits. Quadrature clock phases and phase noise are optimized on-chip with patented calibration algorithms to ensure the best receiver and transmitter performance.