

# QC12864B

## ① PHYSICAL DIMENSION

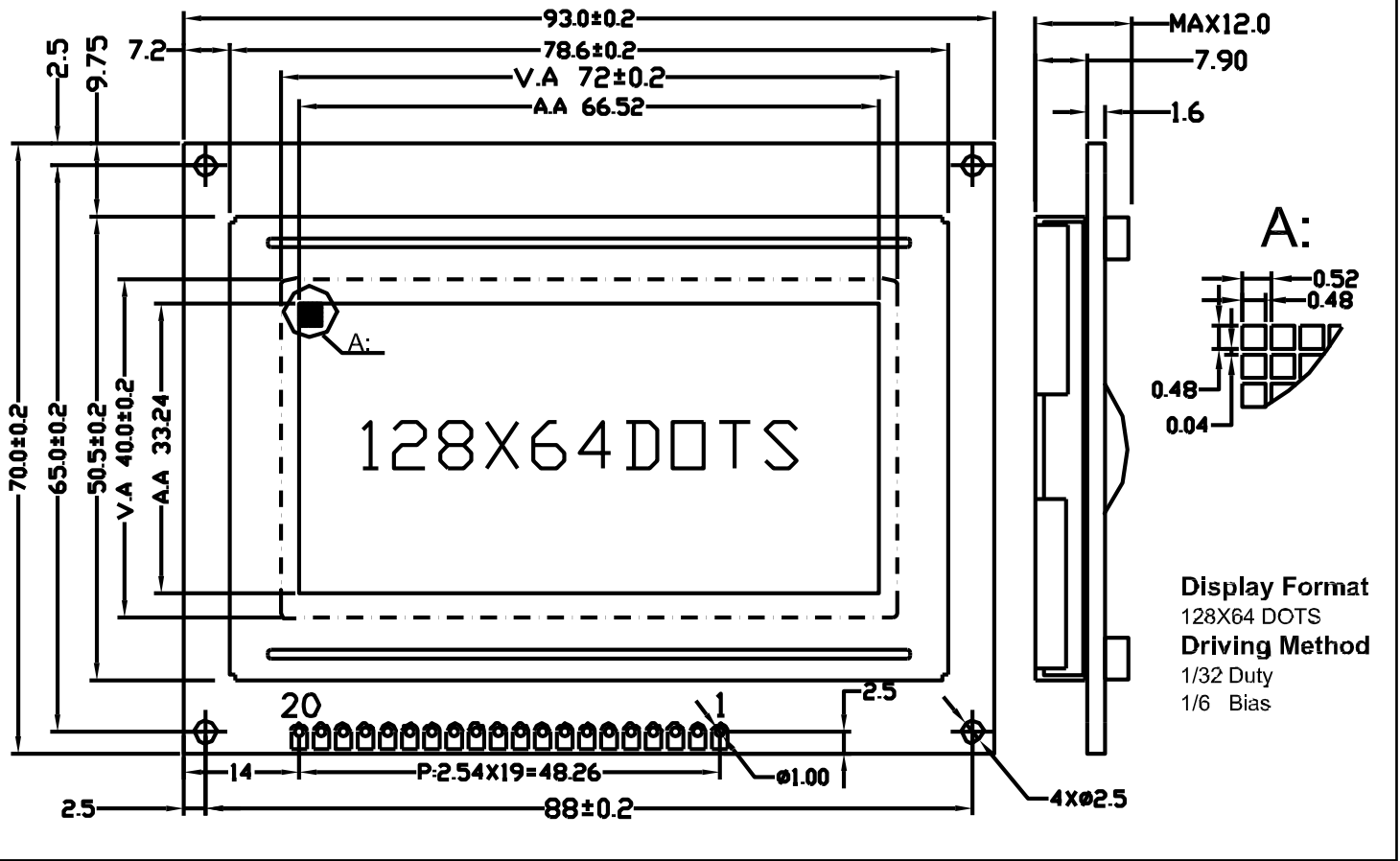

## ② MECHANICAL DATA

ITEM	SPECIFICATION	UNIT
Module Size With B/L (W X H X T)	93.0 X 70.0 X 12	mm
Viewing Area (W X H)	72.0 X 40.0	mm
Number of Dots (W X H)	128 X 64	dots
Dot Pitch (W X H)	0.52 X 0.52	mm
Dot Size (W X H)	0.48 X 0.48	mm
Weight	80.0 (With B/L)	g

## ④ BLOCK DIAGRAM

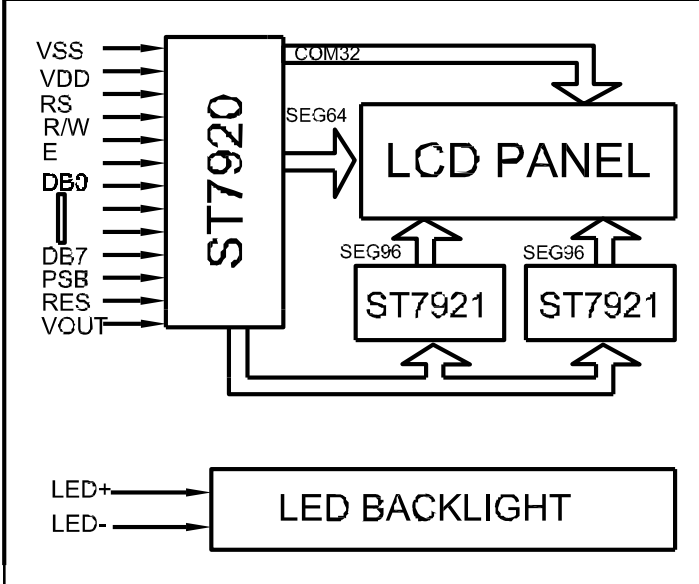

## ③ PIN CONFIGURATION

ITEM	SYMBOL	DESCRIPTION	
1	VSS	VSS Power ground	
2	VCC	VCC Power positive (+5V+10%).	
3	NC/V0	NC/V0 No Connect /Negative voltage Supply for LCD	
4	RS	CS H:Data L:Instruction Code	Serial Chip Select
5	R/W	SID H:Read L:Write	Serial Data
6	E	SCLK Enable trigger.	Serial Clock
7	DB0	NC Data bus [0~7]. There state I/O common terminal.	No Connect
14	DB7		
15	PSB	PSB H: Parallel mode	L: Serial mode
16	NC	NC No Connect	No Connect
17	RST	RST System reset low active.	System reset low active.
18	NC/VEE	NC/VEE No Connect /Negative voltage output	
19	LED_A	LED_A Backlight Anode(+5V).	
20	LED_K	LED_K Backlight Cathode(0V).	

## ⑤ ABSOLUTE MAXIMUM RATINGS (25°C)

PARAMETER	SYMBOL	MIN.	MAX.	UNIT
SUPPLY VOLTAGE LOGIC	VDD	0	5.5	V
SUPPLY VOLTAGE DRIVER	V0-GND	0	15	V
INPUT VOLTAGE	VIN	0	VDD	V