

The AVX logo is located in the top right corner of the page. It consists of the letters 'AVX' in a bold, white, sans-serif font. The 'A' and 'V' are connected, and the 'X' is formed by two intersecting diagonal lines. The background of the entire page is a dark blue gradient with several overlapping, semi-transparent circular patterns that resemble the perforated surfaces of piezoelectric acoustic generators.

AVX

KYOCERA
Piezoelectric Acoustic Generators

Table of Contents

Introduction	2-7
Piezo Ceramic Elements - KBS - XXDA	
External Drive	8-9
Self Oscillating	10-11
Housed Buzzer	
KBS - XXDB	12-13
Tweeter	
KBS - XX - XA/ZA	14-15
Piezo Ringers	
KBS-30DB-1A-20, KBT-33SB-2T-2, KBT-34SB-1T/1A-0, KBT-44SB-1A, KBS-50DL-05C	16-17
Magnetic Receivers	
PCRT	18-19
Ceramic Receivers	
KBT-XXRB-2S/CN	20

Notice: All statements, information, and data given herein are believed to be accurate and reliable, but are presented without guarantee, warranty, or responsibility of any kind, express or implied. Statements or suggestions concerning possible use of our products are made without any representation or warranty that any such use is free of patent infringement and are not recommendations to infringe any patent. The user should not assume that all safety measures are indicated or that other measures may not be required. Specifications are typical and may not apply to all applications.

Piezoelectric Acoustic Generators

Introduction

AVX-Kyocera manufactures a wide variety of piezoelectric acoustic generator elements. These include external drive and self-oscillating buzzers, beepers, ringers and receivers.

Piezoelectric acoustical transducers are non-mechanical contact devices and feature the following advantages:

- Free from RF noise and contact sparking
- Simple, compact and light weight
- Consume little power and have long life
- Generate various timbres of pitches

Examples of applications are: telephones, watches, calculators, appliances, automobiles, smoke detectors and a wide variety of other electronic equipment.

The basic element in all of these is a piezoelectric ceramic mounted on a metal diaphragm. When AC voltage is applied across the electrodes of the piezoelectric ceramic it expands and contracts at the frequency applied. This causes the metal diaphragm to bend, producing sound waves (Figures 1 and 2).

The metal diaphragm is usually brass or stainless steel and less than 0.5 mm thick. PZT ceramic material is used as the piezoelectric element. This element is designed so that the mechanical resonant frequency matches the frequency of the driving signal.

Piezoelectric Acoustic Generators are available in two types:

1. Two-terminal type
2. Three-terminal type

The two-terminal type works when signal voltage is applied on the metal diaphragm as one electrode and the conductive-material-screened piezoelectric element as the other electrode.

The three-terminal type has a split electrode on the piezoelectric element. When the signal is applied between 2 and 1 in Figure 3, the phase shifted signal will be induced between 3 and 1 so that it works as a piezoelectric transformer. The phase shifted signal can be used as the feedback component in a simple oscillation circuit which operates automatically at the natural resonant frequency of the element.

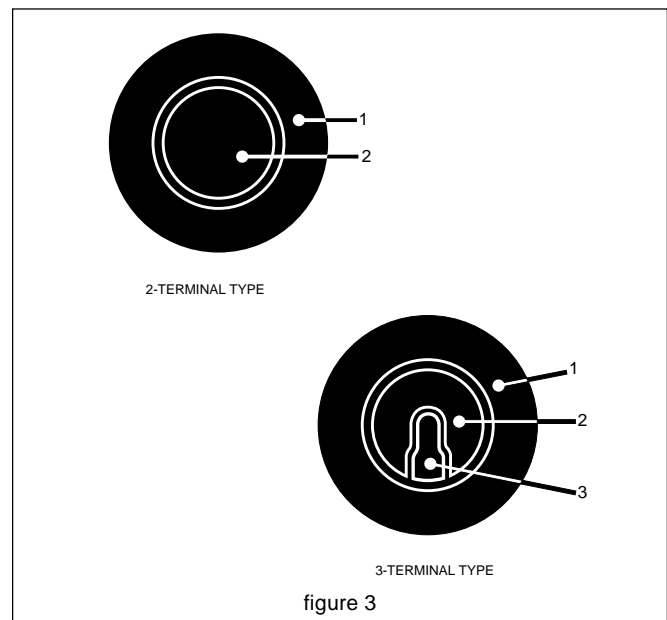
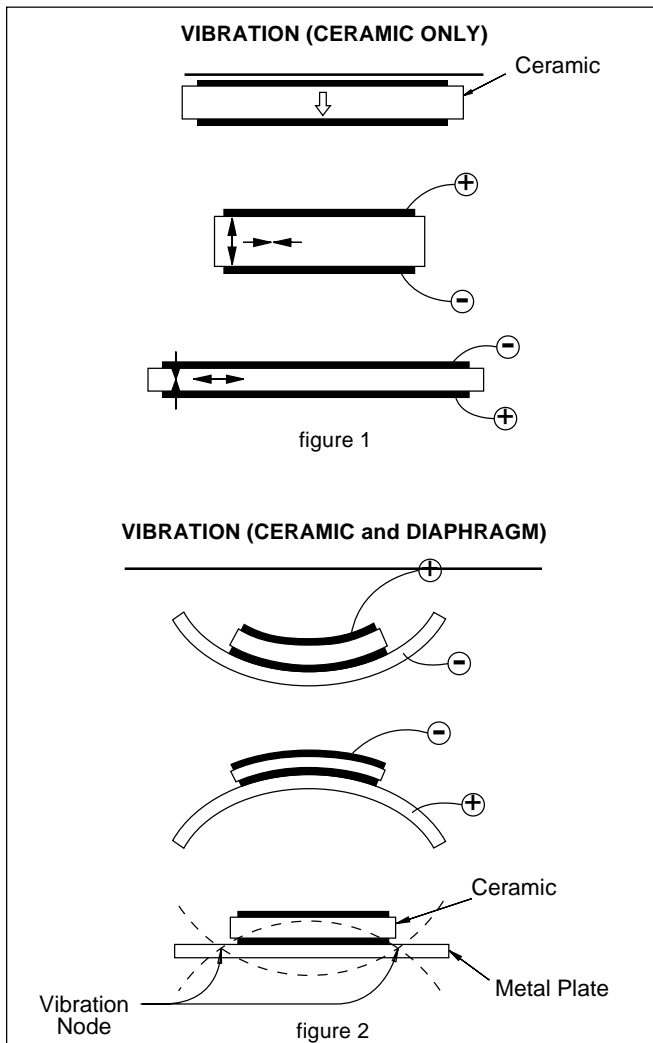

Impedance Characteristics

The equivalent circuit of piezoelectric acoustic generators (2-terminal type) can be explained by the same equivalent circuit used for quartz crystal resonators and ceramic resonators. The mechanical resonance is shown by the series resonance circuit of R_o , L_o , C_o , and its resonant frequency (f_r) is determined as follows:

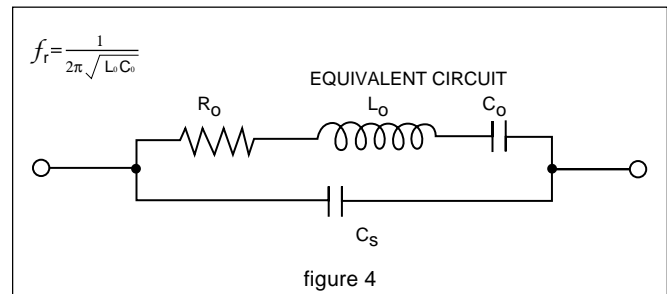

In the case of the piezoelectric transducer the shunt capacitance is larger than that of other resonators. Therefore, the total impedance is capacitive.

Mounting

The various mounting methods for piezoelectric acoustic elements are discussed below:

Simple Mounting Method

The simplest method is to stick the piezo acoustic element to the plate using double-sided adhesive tape. However, the sound pressure will not be optimum.

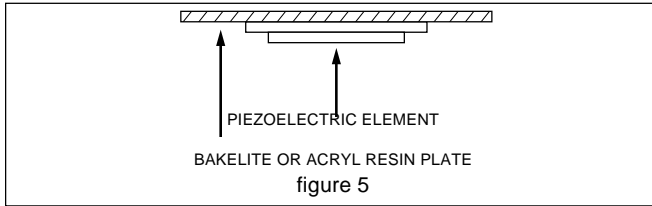

Circumference Fixing Method

This method is to fix the outside circumference of the element to the supporting ring of the plate. Considerable sound pressure can be obtained covering a wide frequency range around the resonant frequency.

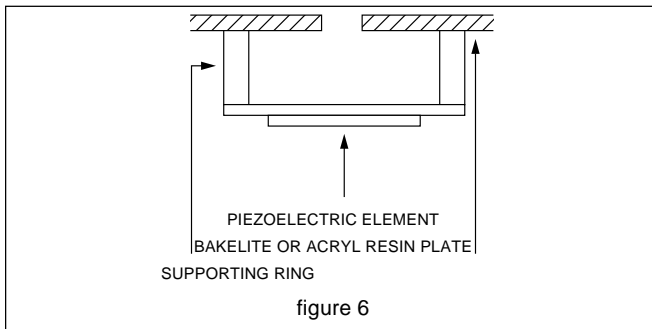

Nodal Mounting Method

This method is to fix the nodal diameter of the element to the supporting ring of the plate. Loud sound pressure can be obtained at the resonant frequency. The sound pressure will drastically drop when the frequency is shifted from the resonant frequency.

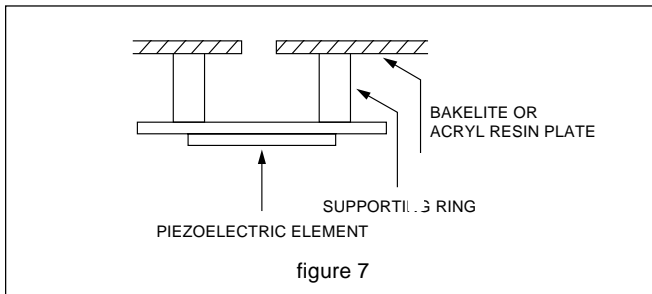

The adhesive agent used between the element and the support ring should be elastic, such as silicon rubber.

Designing the Fixture

Factors affecting the sound pressure of the piezoelectric acoustic element are as follows:

- 1) resonance frequency of the element
- 2) cavity resonance (cavity design of the case/casing method)
- 3) resonance of sound body (mass after casing)

Maximum sound pressure level can be achieved at the point where the 3 factors overlap. Taking the oscillation frequency fluctuation into consideration, the fixture is designed so that peak points are slightly overlapping with one another.

Case Design for Circumference Mounting Method

When designing a case for circumference mounting, the cavity resonant frequency of the case (f_0) is determined by the following formula:

$$f_0 = \frac{C}{2\pi} \sqrt{\frac{S}{V(t + 1.5\sqrt{\frac{S}{\pi}})}} \text{ (Hz)}$$

where: V: cavity volume (m^3)

$$V = \frac{\pi D^2 T}{4}$$

S: area of open hole (m^2)

$$S = \frac{\pi d^2}{4}$$

t: Length of open hole (m)

C: sound velocity
C=344 m/sec

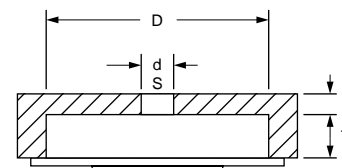

figure 8

For example, when KBS-35DA-3A (resonant frequency $f_r = 2.9 \pm 0.5$ kHz) is mounted in a case where the size is: $D = 33.5$ mm, $d = 5.5$ mm, $T = 2$ mm, $t = 1$ mm, the formula for f_0 is explained as follows:

$$f_0 = \frac{Cd}{2\pi D} \sqrt{\frac{1}{T(t + 0.75d)}}$$

figure 9

Then, the cavity resonant frequency shall be 2,807 Hz.

Case Design for Nodal Mounting Method

The piezoelectric acoustic element with feedback tab (3-terminal type) should be oscillated in the basic mode and supported at the nodal point to obtain stability.

The nodal point of the disc which has diameter "a" is located at the point of 0.224a from the edge of the disc. However, the element has a smaller ceramic disc than metal disc, which results in the nodal point being located at 0.15a to 0.20a from the metal disc edge.

A popular case design is shown in figure 10. The cavity is designed in front of the transducer together with a short pipe for the sound output release. The resonant frequency is determined by the same formula as for the circumference design.

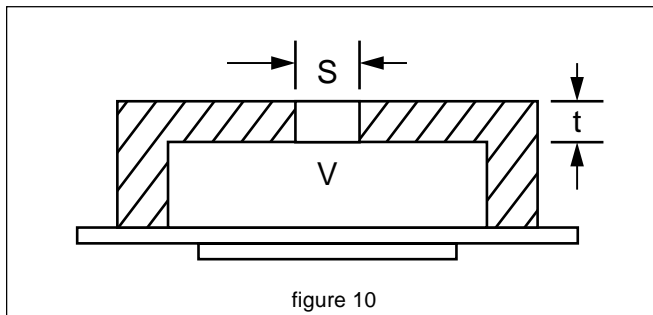

Measuring Methods

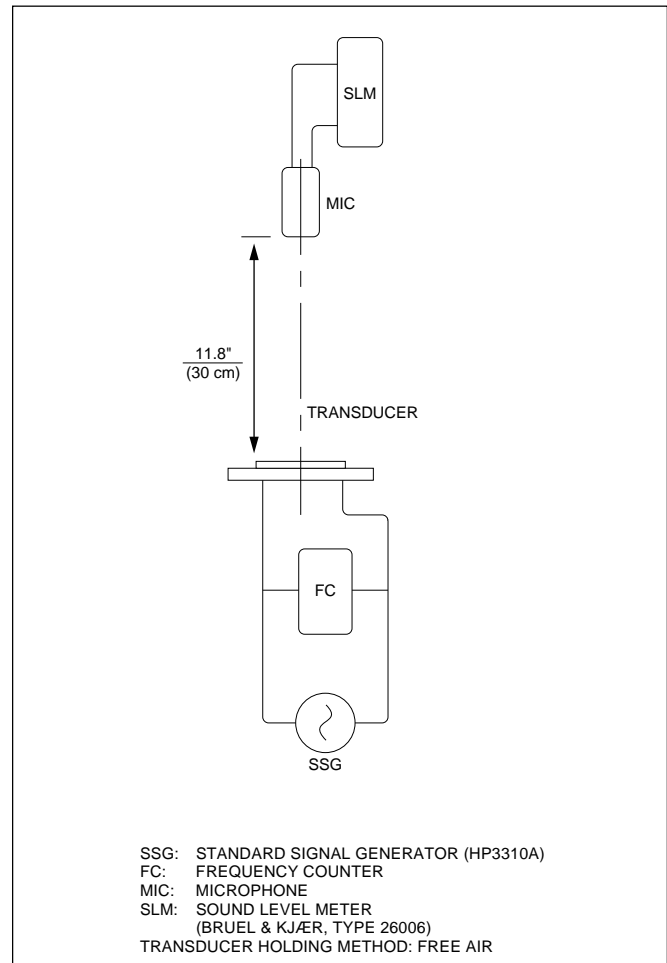

figure 12

Sound Pressure Level

Resonant Frequency (f_r), Resonant Impedance (R_o)

The resonant frequency (f_r) is defined as the reading at the point where impedance is at its minimum. Its impedance is defined as the resonant impedance.

Static Capacitance (C_d)

Static Capacitance measuring frequency is 1 kHz, except for low resonant frequency devices which are measured at 120 Hz. (See individual specifications.)

Suggestions for Handling

In order to maximize the quality of piezoelectric elements, it is necessary that proper handling procedures be used.

Do not operate or store for a long time under conditions of high temperature and high humidity.

- Piezoelectric characteristics may degrade when kept at more than 80° C for a long time.
- The electrodes may be shorted if a drop of water falls onto the silver electrode area of the transducer.

Keep soldering time to a minimum.

- Soldering operation must be less than 320°C and completed within 1.5 seconds.
- 2% silver solder for silver electrodes must be used to prevent leaching.
- Piezoelectric acoustic elements are supplied with leads for our customers' convenience. The specifications are as follows:
 - 1) Standard lead specification AWG#28 and AWG#32 (7 strand copper wires covered with red color vinyl insulation)
 - 2) Standard length (mm) 50, 75, 100, 125, 150

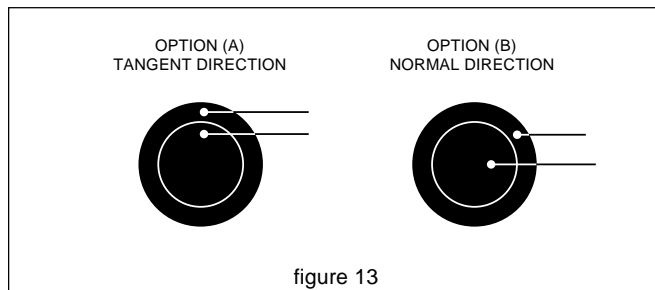

3) How leads may be soldered:

Do not apply unnecessary weight to the element

- The transducer consists of a one hundred micron thick metal plate and also a one hundred micron thick ceramic plate. The ceramic plate will crack when too much weight is applied to the device.

Mechanical Shock

- If equipment (with a piezo-electric transducer) receives a mechanical shock, resulting in stress to the piezoelectric element, an electric feedback can result, damaging other components in the circuits.

Attention must be paid to the assembled location in order to generate maximum sound output.

Remember that the 3-terminal type is a part of the oscillation circuit.

- Do not place a cover in front of the buzzer, if possible.
- When assembling, do not deform or bend the transducer fixture. Deformation of the transducer changes the oscillation condition.

NOTE: Wherever possible, the piezo devices should be capacitive coupled to avoid permanent DC bias and possible long term damage.

Drive Circuits

Because the impedance of the piezoelectric buzzer (2-terminal type) is capacitive, the drive circuit can be designed utilizing the transducer as a capacitor.

Drive circuits are classified into two types. One type is the amplification type which amplifies and supplies input signal (from IC, etc.) to the transducer. The other is the oscillation type, in which the transducer constitutes a part of the circuit together with other active elements.

Typical circuit types are as follows:

Table I

Transducer Drive Circuit	
Amplification Type	Oscillation Type
Load Resistance Type	Blocking Oscillation Type
Complementary Type	Multivibrator Type
Load Inductance Type	CR Oscillation Type
	3-Terminal Buzzer Type
	IC Type

Amplification Type Circuits

Load Resistance Type

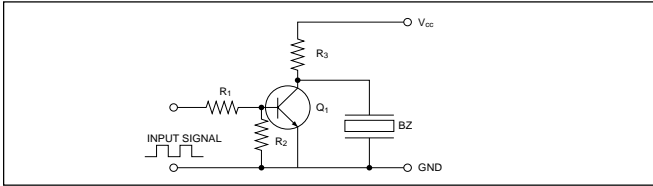

This is the simplest circuit. Applied voltage V_{pp} will be V_{cc} . Loud sound pressure cannot be achieved. For example,

- $V_{cc}=5V$
- B2=KBS-27DB-3A
- $f=3.3kHz$
- $R_1=30k\Omega$
- $R_2=15k\Omega$
- $R_3=1k\Omega$

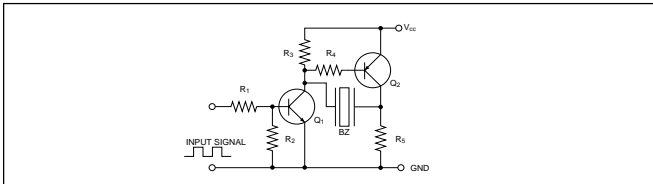

Two-step amplification using transistors: The transducer is connected between the collectors of each transistor making the applied voltage (V_{pp}) $2 \times V_{cc}$.

Complementary Type

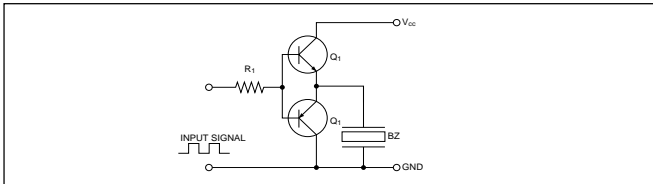

In this example, the sound pressure level is relatively low. It is effective for reducing current consumption, and when a highly efficient circuit is the goal.

Load Inductance Type

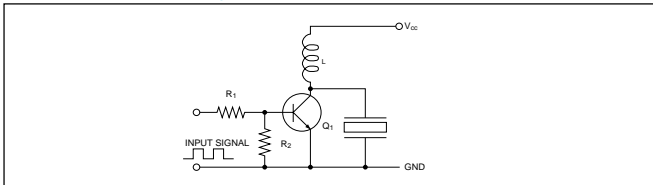

High voltage can be applied to the transducer by using load inductance. The smaller the "L" is, the higher the peak voltage. However, the current consumption will increase, also increasing the spurious oscillation, which results in degradation of the tone quality.

NOTE: Wherever possible, the piezo devices should be capacitive coupled to avoid permanent DC bias and possible long term damage.

Oscillation Type Circuits

Blocking Oscillation Type

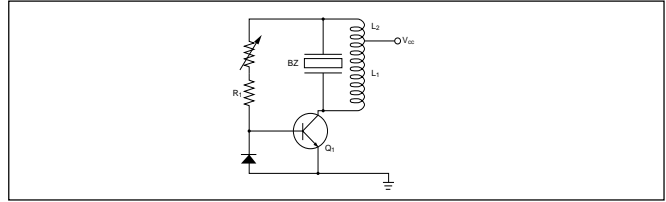

This is the most effective circuit when loud sound pressure is required, and the supply voltage is low. This circuit operates in the same manner as the Load Inductance type. The duty factor will be large and the spurious oscillation will increase if the inductance of the transformer is small.

- $L_1=550T$ (30mH)
- $L_2=150T$
- BZ=KBS-27DB-3A

V_{cc}	Current	Frequency	R_1
1.5V	2.2mA	3kHz	38.9k Ω
3 V	4.1mA	3kHz	63.7k Ω
4.5V	6.0mA	3kHz	74.8k Ω

CR Oscillation Type

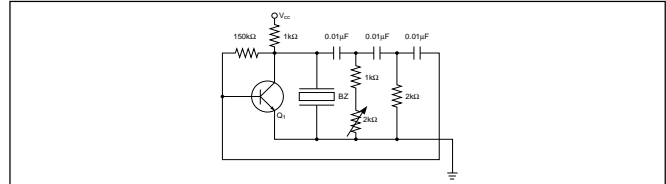

It is easy to generate a sine wave when the high frequency component is small, which will result in good tone quality. However, sound pressure is low. The larger the h_{FE} of the transistor is, the more stable the oscillation.

V_{cc}	Current	Frequency
15.5V	7.7mA	2.25-3.3kHz
12 V	6.0mA	2.2 - .1kHz
9 V	4.6mA	2.1 -3.0kHz
6 V	3.0mA	2.1 -2.9kHz
-4.5V	2.2mA	2.0 -2.8kHz

Multivibrator Type

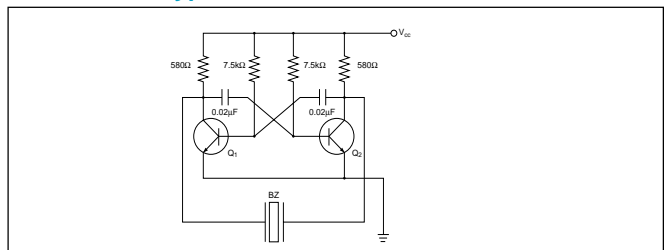

The transducer is connected between the collectors of two transistors of a multivibrator which generates a stable square wave. The shoulders of the square wave are rounded due to this, but V_{pp} will be double V_{cc} .

V_{cc}	Current	Frequency
1.5V	3.3mA	2.8kHz
3 V	7.1mA	3.2kHz

Oscillation Type Circuits

3-Terminal Buzzer Type

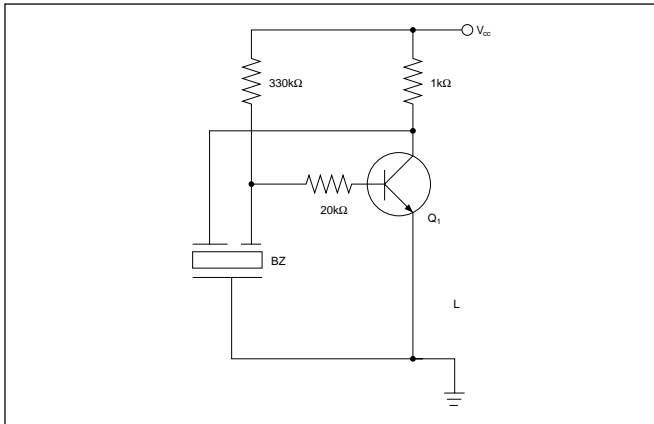

A Piezo Transducer with a feedback tab makes the circuit oscillate without inductors and capacitors. The number of components is reduced and it is possible to generate from a sine wave to a trapezoidal wave.

V_{cc}	Current	Frequency
15 V	8.2mA	2.55kHz
12 V	6.4mA	2.55kHz
9 V	4.6mA	2.55kHz
6 V	3.0mA	2.55kHz
4.5V	2.0mA	2.55kHz
3 V	1.1mA	2.55kHz

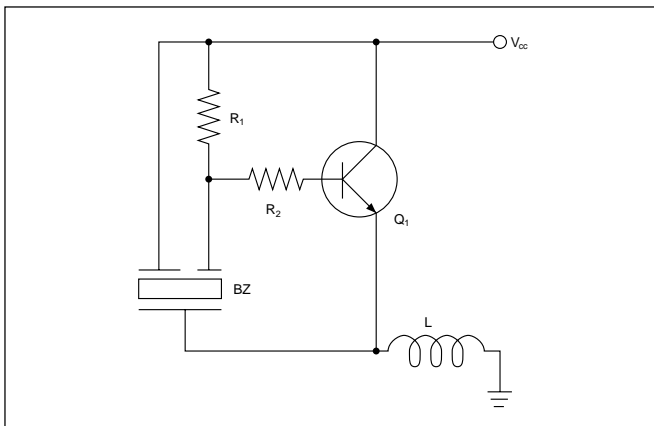

In order to increase the sound pressure level, a coil can be added to the circuit.

IC Type

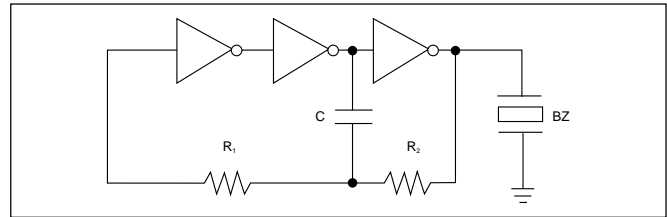

It is easy to build this circuit by using CMOS inverters, such as MC14049, and MC14069. The oscillation frequency is in proportion to $1/R_2C$.

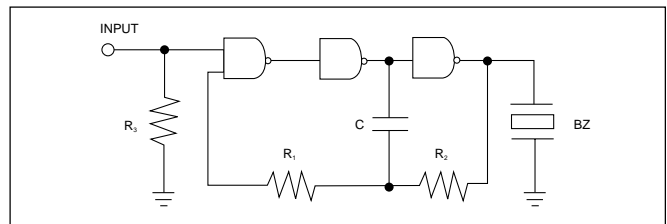

It is easy to do on-off oscillation by using a CMOS NAND gate such as MC14011. When the input terminal is high, the transducer works. When the input terminal is low, it stops.

This is an example of a circuit that will generate various sounds using one MC14069. The frequency determined by R_2, C_1 oscillates 1kHz to 5kHz and 2 times the V_{cc} is applied to the transducer as V_{pp} .

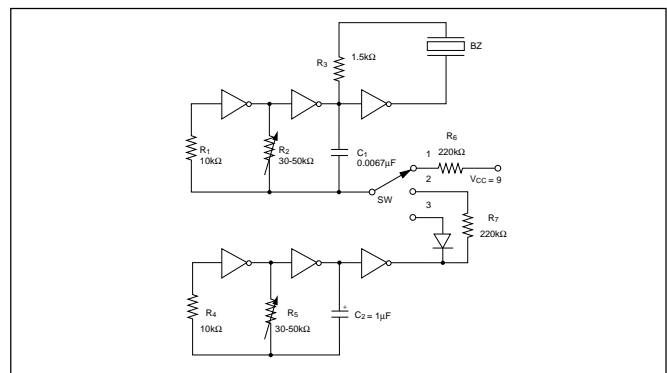

R_5, C_2 determines the on and off intervals. It is variable in the range of 0.1 to 3 seconds. By changing the switch position, different sounds are generated.

- Position 1: continuous sound
- Position 2: 2 different frequencies
- Position 3: interrupted sound

NOTE: Wherever possible, the piezo devices should be capacitive coupled to avoid permanent DC bias and possible long term damage.

NOTE: Please investigate in detail to confirm that you will not be in violation of the patents of others when using the above circuit examples in volume production.

Piezoelectric Acoustic Generators

Piezo Ceramic Elements - External Drive Type

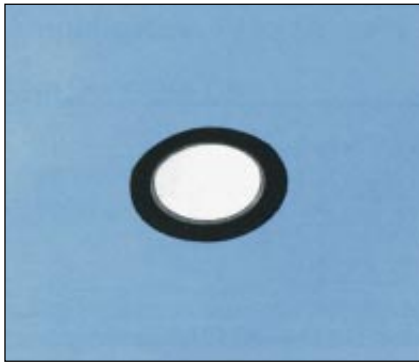

Features:

- 1) Wide variety of tones possible by connection to external circuits.
- 2) Low power consumption, thin, light-weight
- 3) No-contact design makes element highly reliable and eliminates noise problems

Applications:

- 1) Clocks, electronic calculators, pocket alarms, cameras.
- 2) Equipment containing microprocessors (microcomputers, microwave ovens, TVs, stereos, automobiles, etc.)
- 3) Telecommunications equipment (facsimile machines, telephones)
- 4) Electronic medical equipment

How To Order:

KBS - 20 DA - 7 A S - 1

- ① Model
- ② Diameter (mm), eg. 20
- ③ Piezo Ceramic Element
- ④ Resonant Frequency in kHz
- ⑤ 2 Electrode Types
A = Element only
C = With lead wires
- ⑥ Metal Disc Material
S = Stainless Steel
Blank = Brass
- ⑦ Modifier code for lead wire spec.

Dimensions:

A type - 2 Electrodes

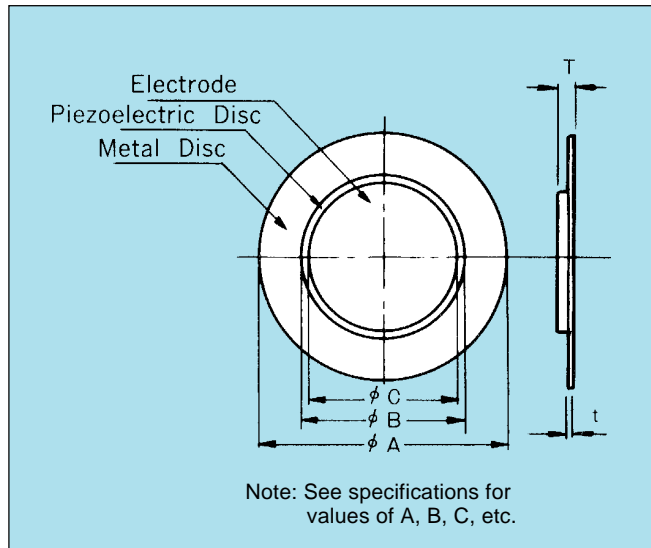

C type - 2 Electrodes with Lead Wires

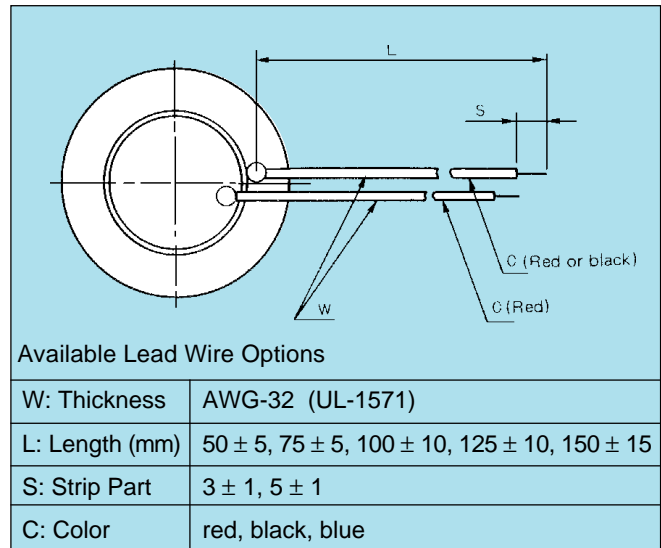

Temperature Characteristics (KBS-27DA-5A)

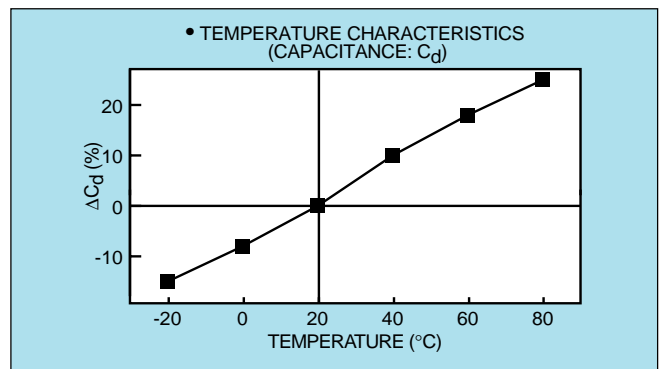
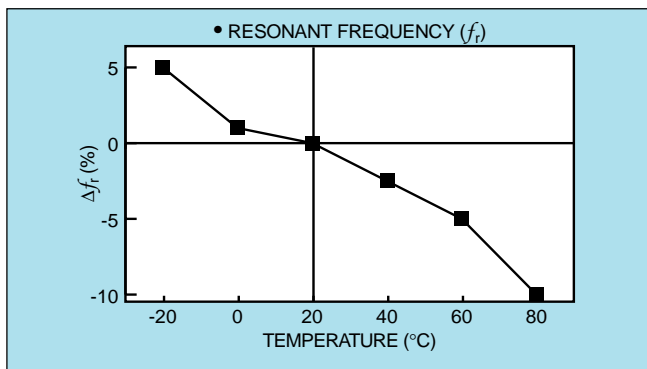

Piezo Ceramic Elements - External Drive Type

Specifications (A type)

Model No.	Resonant Frequency (kHz)	Resonant Impedance (Ω)	Static Capacitance (pF)	Dimensions (mm)					Metal Disc Material
				Metal Disc (ϕ A)	Ceramic Disc (ϕ B)	Electrode (ϕ C)	Total Thickness (T)	Metal Disc Thickness (t)	
KBS-13DA-12A	12.0 \pm 1.2	700	5,000 \pm 30%	13.4 \pm 0.1	10.0 \pm 0.3	(9.0)	0.36 \pm 0.1	0.15 \pm 0.03	Brass
KBS-15DA-9A-2	10.5 \pm 3.0	600	8,000 \pm 30%	15.0 \pm 0.1	12.0 \pm 0.3	(11.0)	0.42 \pm 0.1	0.20 \pm 0.03	Brass
KBS-20DA-7A	6.6 \pm 1.0	300	10,000 \pm 30%	20.0 \pm 0.1	14.2 \pm 0.3	(13.0)	0.45 \pm 0.1	0.20 \pm 0.03	Brass
KBS-20DA-7AS	7.5 \pm 1.0	300	10,000 \pm 30%	20.0 \pm 0.1	14.2 \pm 0.3	(13.0)	0.45 \pm 0.1	0.20 \pm 0.03	Stainless Steel
KBS-23DA-4A	4.0 \pm 1.0	600	12,000 \pm 30%	22.8 \pm 0.1	15.0 \pm 0.3	(14.0)	0.41 \pm 0.1	0.15 \pm 0.03	Brass
KBS-27DA-3A	3.0 \pm 0.5	1,500	10,000 \pm 30%	27.0 \pm 0.1	14.2 \pm 0.3	(13.0)	0.49 \pm 0.1	0.25 \pm 0.03	Brass
KBS-27DA-5A	4.6 \pm 0.5	200	20,000 \pm 30%	27.0 \pm 0.1	20.2 \pm 0.3	(19.0)	0.53 \pm 0.1	0.25 \pm 0.03	Brass
KBS-27DA-5AS	5.0 \pm 0.5	200	20,000 \pm 30%	27.0 \pm 0.1	20.2 \pm 0.3	(19.0)	0.53 \pm 0.1	0.25 \pm 0.03	Stainless Steel
KBS-30DA-1A	1.4 \pm 0.5	500	★48,000 \pm 30%	30.0 \pm 0.1	20.2 \pm 0.3	(19.0)	0.23 \pm 0.1	0.10 \pm 0.03	Brass
KBS-35DA-3A	2.9 \pm 0.5	200	30,000 \pm 30%	35.0 \pm 0.1	25.0 \pm 0.5	(23.5)	0.53 \pm 0.1	0.25 \pm 0.03	Brass
KBS-38DA-2AL	1.5 \pm 0.3	300	★36,000 \pm 30%	38.0 \pm 0.1	25.0 \pm 0.5	(23.5)	0.38 \pm 0.1	0.15 \pm 0.03	42-Alloy
KBS-47DA-06A-3	0.70 \pm 0.20	700	★120,000 MIN.	46.94 \pm 0.1	25.0 \pm 0.5	(23.5)	0.28 \pm 0.1	0.15 \pm 0.03	Brass
KBS-50DA-06A	0.65 \pm 0.25	1,500	★120,000 MIN.	50.0 \pm 0.1	25.0 \pm 0.5	(23.5)	0.28 \pm 0.1	0.15 \pm 0.03	Brass
KBS-50DA-08A-3	0.87 \pm 0.25	3,000	★40,000 \pm 30%	50.0 \pm 0.1	25.0 \pm 0.5	(23.5)	0.44 \pm 0.1	0.20 \pm 0.03	Brass
KBS-50DA-1A	0.90 \pm 0.30	600	★45,000 \pm 30%	50.0 \pm 0.1	30.0 \pm 0.5	(28.5)	0.44 \pm 0.1	0.20 \pm 0.03	Brass

★ Measured at 120Hz, all others at 1kHz

Application Circuits For External-Drive Oscillation Buzzer

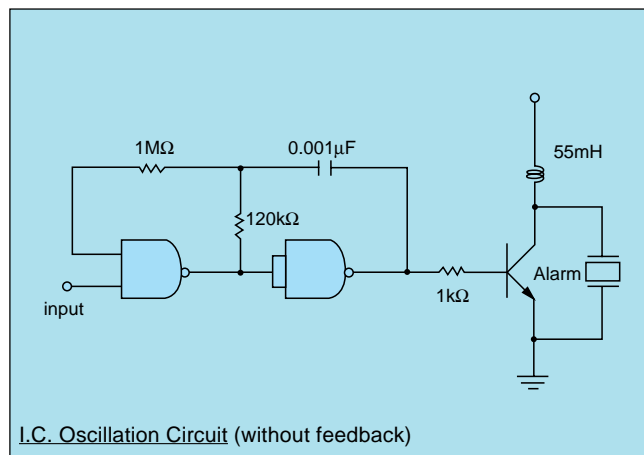
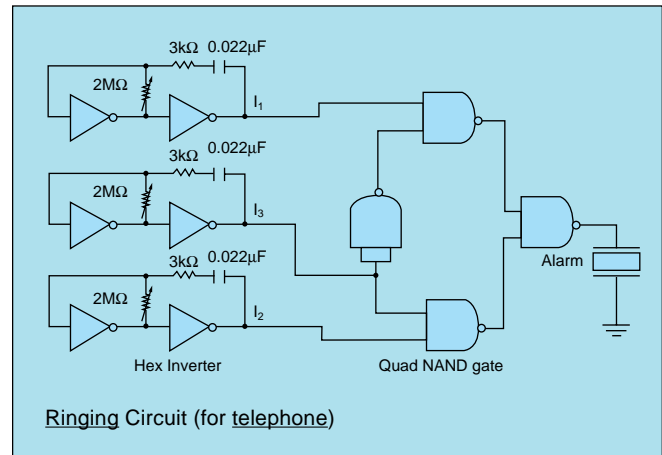
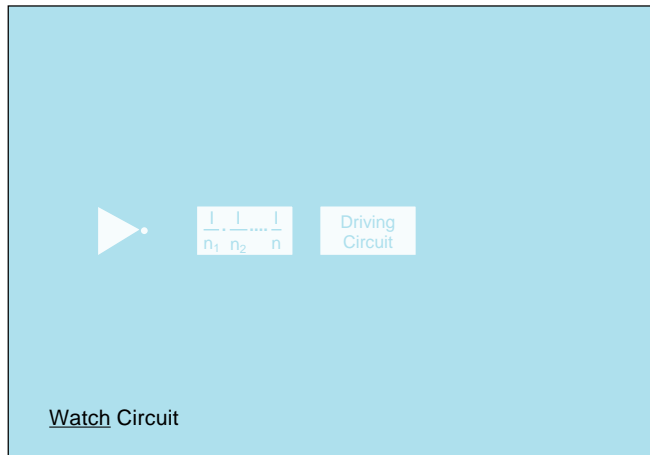

NOTE: Wherever possible, the piezo devices should be capacitive coupled to avoid permanent DC bias and possible long term damage.

Piezo Ceramic Elements - Self Oscillating Type

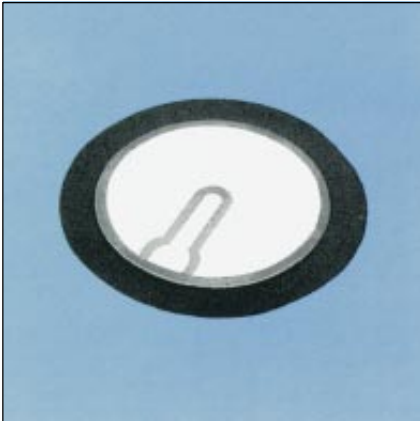

Features:

- 1) Connection to a self oscillating circuit produces clear sounds with high sound pressure level
- 2) Low power consumption
- 3) Thin, lightweight
- 4) No-contact design makes element highly reliable and eliminates noise problems

Applications:

- 1) Smoke detectors, security alarms, and other warning devices
- 2) pocket pager/alarms, electronic calculators, and consumer products
- 3) Telephones

How To Order:

KBS - 35 DA - 3 G _ - 3

- ① Model
- ② Diameter (mm) eg. 35
- ③ Element shape (Disc-Shaped Piezoelectric Buzzer)
- ④ Resonant Frequency: eg. 3kHz
- ⑤ 3-Terminal Electrode Type
FC = F-Shaped Pattern
G = G-Shaped Pattern
GC = G-Shaped Pattern with lead
- ⑥ Disc Material
S = Stainless Steel
Blank = Brass
- ⑦ Classification for elements of the same shape (in case of partial modification of standard specifications only)

Dimensions

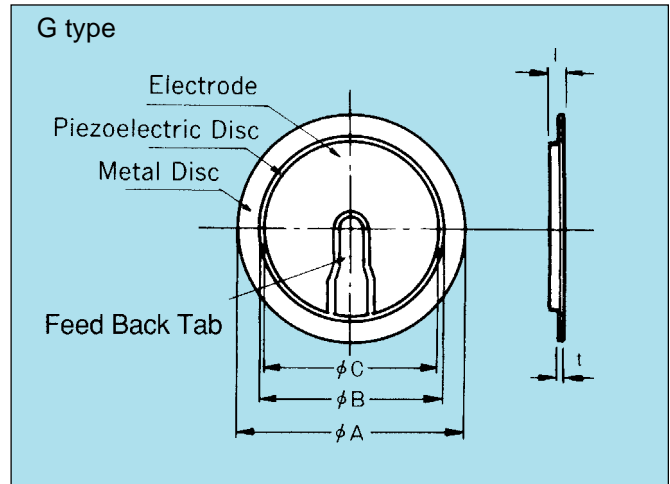
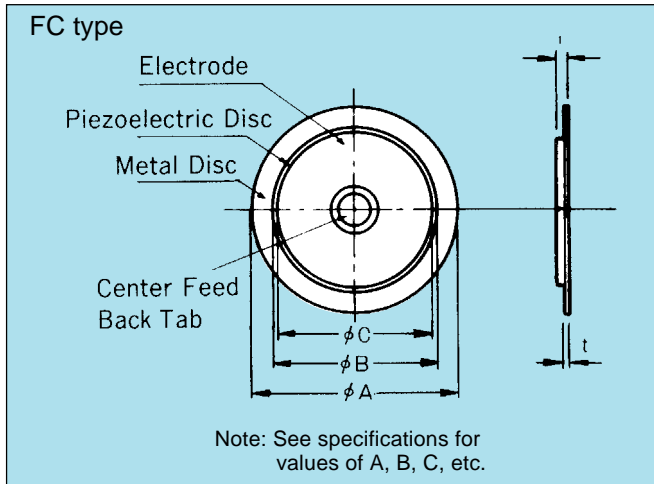

Standard AVX/Kyocera Lead Wire (3 electrode devices)

W: Thickness	AWG-32 (UL-1571)
L: Length (mm)	50 ± 5, 75 ± 5, 100 ± 10, 125 ± 10, 150 ± 15
S: Stripped Part Length (mm)	3 ± 1, 5 ± 1
C: Color	red, black, blue
GC type only. FC not available with lead wires.	

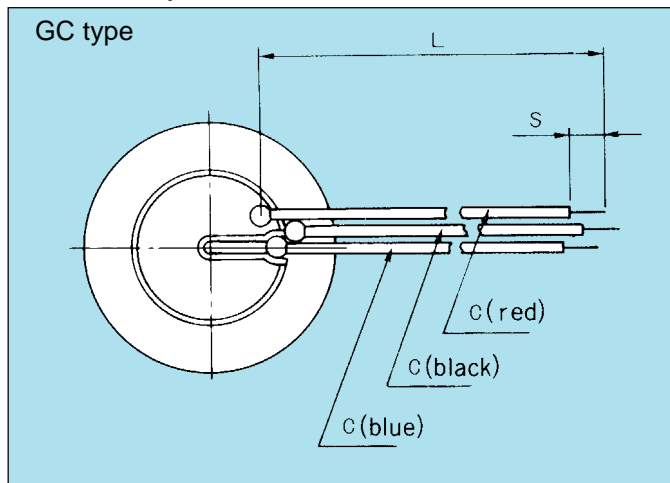

Piezo Ceramic Elements - Self Oscillating Type

Specifications

(G type Self Oscillating Type)

Model No.	Resonant Frequency (kHz)	Resonant Impedance (Ω)	Static Capacitance (pF)	Dimensions (mm)					Metal Disc Material
				Metal Disc (ϕ A)	Ceramic Disc (ϕ B)	Electrode (ϕ C)	Total Thickness (T)	Metal Disc Thickness (t)	
KBS-27DA-5G	4.6 \pm 0.5	200	16,000 \pm 30%	27.0 \pm 0.1	20.2 \pm 0.3	(19.0)	0.53 \pm 0.1	0.25 \pm 0.03	Brass
KBS-35DA-3G	2.9 \pm 0.5	200	25,000 \pm 30%	35.0 \pm 0.1	25.0 \pm 0.5	(23.6)	0.53 \pm 0.1	0.25 \pm 0.03	Brass
KBS-35DA-3GS	3.2 \pm 0.5	200	25,000 \pm 30%	34.55 \pm 0.1	25.0 \pm 0.5	(23.6)	0.53 \pm 0.1	0.25 \pm 0.03	Stainless Steel
KBS-35DA-3GS-6	3.2 \pm 0.3	200	25,000 \pm 30%	34.55 \pm 0.1	25.0 \pm 0.5	(23.5)	0.53 \pm 0.1	0.25 \pm 0.03	Stainless Steel
KBS-41DA-2G	2.2 \pm 0.3	200	20,000 \pm 30%	41.47 \pm 0.1	25.0 \pm 0.5	(23.6)	0.53 \pm 0.1	0.35 \pm 0.04	Brass

(F type)

Model No.	Resonant Frequency (kHz)	Resonant Impedance (Ω)	Static Capacitance (pF)	Dimensions (mm)					Metal Disc Material
				Metal Disc (ϕ A)	Ceramic Disc (ϕ B)	Electrode (ϕ C)	Total Thickness (T)	Metal Disc Thickness (t)	
KBS-35DA-3FCS	3.2 \pm 0.5	200	25,000 \pm 30%	34.55 \pm 0.1	25.0 \pm 0.5	(23.0)	0.53 \pm 0.1	0.25 \pm 0.03	Stainless Steel

Application Circuits for Self-Drive Oscillation Buzzer

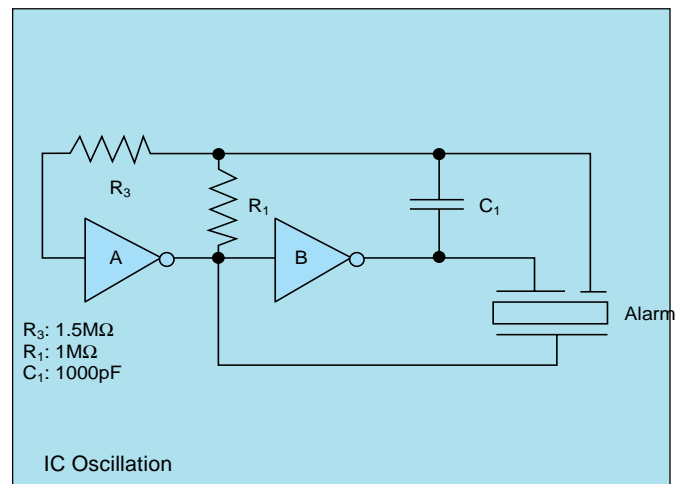
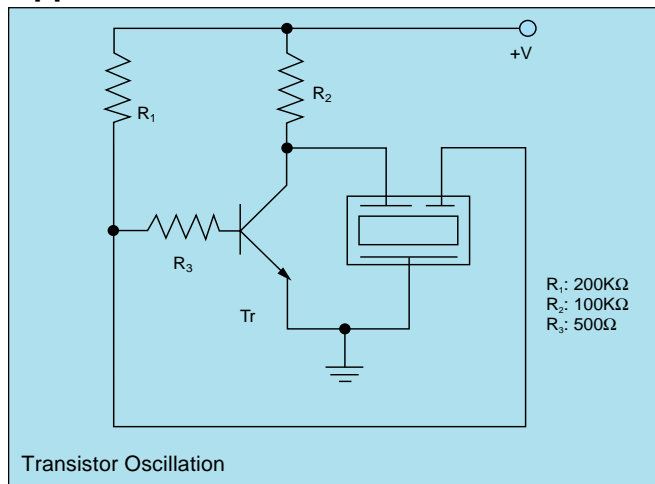

NOTE:

Wherever possible, the piezo devices should be capacitive coupled to avoid permanent DC bias and possible long term damage.

Piezoelectric Acoustic Generators

Housed Buzzers

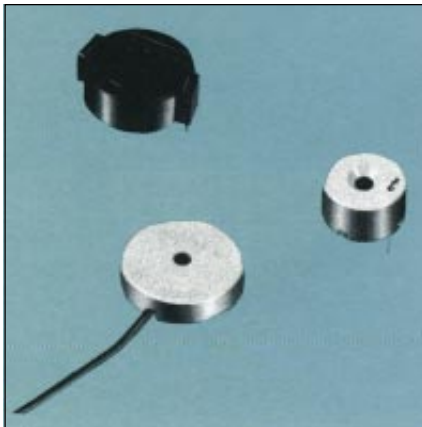

Features:

- 1) High sound pressure with low power consumption
- 2) Compact, lightweight
- 3) No-contact design makes element highly reliable and eliminates noise problem
- 4) Easily mountable
- 5) A wide variety of tones can be generated depending on casing design

Applications:

- 1) Telephone ringers
- 2) Confirmation tones in various office automation equipment
- 3) Used in a variety of consumer products such as microwave ovens and refrigerators
- 4) Clocks, toys games
- 5) Automobiles

How To Order:

KBS - 27 DB - 3 A

- ① ② ③ ④ ⑤
- ① Model
 - ② Diameter: eg. 27mm
 - ③ Housed Buzzer
 - ④ Resonant Frequency: eg. 3kHz
 - ⑤ Lead Types
A = Lead Wire
P = Pins

Specifications (Casing Type Piezoelectric Buzzers)

Model No.	Sound Pressure Level	Static Capacitance
KBS-13DB-4P-2	73dB Min. 4.096 kHz 10Vp-p SQ. 30cm	10nF ± 30%
KBS-20DB-2P-0 or KBS-20DB-2P-8 (U.S.)	75dB Min. 2.048 kHz 10Vp-p SQ. 30cm	22nF ± 30%
KBS-20DB-3P-0	65dB Min. 3.000 kHz 10Vp-p SQ. 30cm	17nF ± 30%
KBS-20DB-4P-0	77dB Min. 4.096 kHz 10Vp-p SQ. 30cm	14nF ± 30%
KBS-20DB-6P-2	75dB Min. 6.000 kHz 10Vp-p SQ. 30cm	12nF ± 30%
KBS-15DB-4A	72dB Min. 4.096 kHz 10Vp-p SQ. 30cm	9.5nF ± 30%
KBS-20DB-4A-22	70dB Min. 4.000 kHz 10Vp-p SQ. 30cm	17nF ± 30%
KBS-20DB-5A	75dB Min. 5.000 kHz 10Vp-p SQ. 30cm	10nF ± 30%
KBS-27DB-2A-5	70dB Min. 2.500 kHz 10Vp-p SQ. 30cm	46nF ± 30%
KBS-27DB-3A	75dB Min. 3.000 kHz 10Vp-p SQ. 30cm	20nF ± 30%

OSCILLATION FREQUENCY VS. SOUND PRESSURE

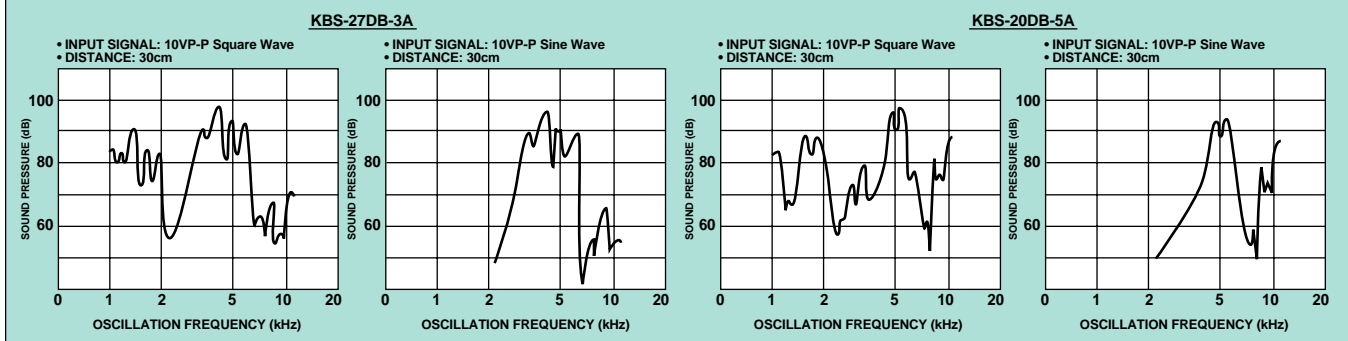

● Relationship between Distance and Sound Pressure level

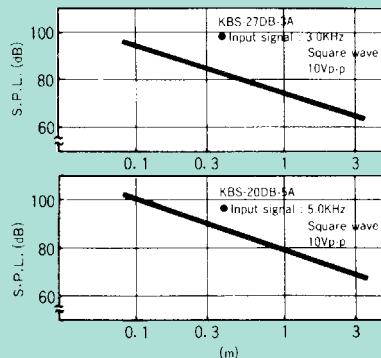

● Relationship between input Voltage and Sound Pressure level

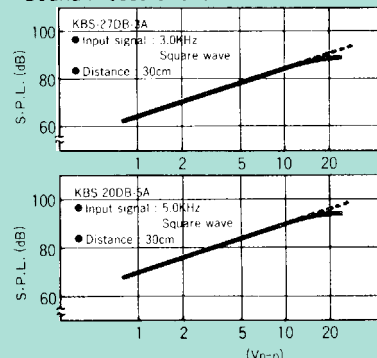

Housed Buzzers

Dimensions

KBS-13DB-4P-2

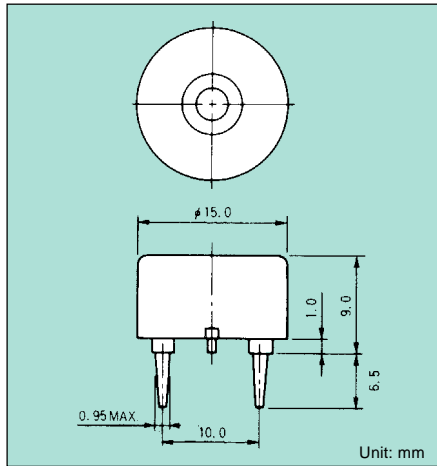

KBS-20DB-2P-0

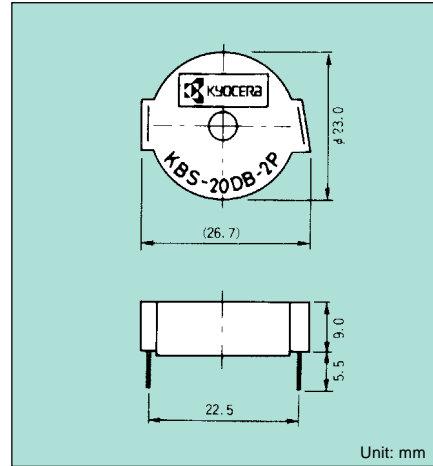

KBS-20DB-3P-0 / KBS-20DB-4P-0 / KBS-20DB-6P-0

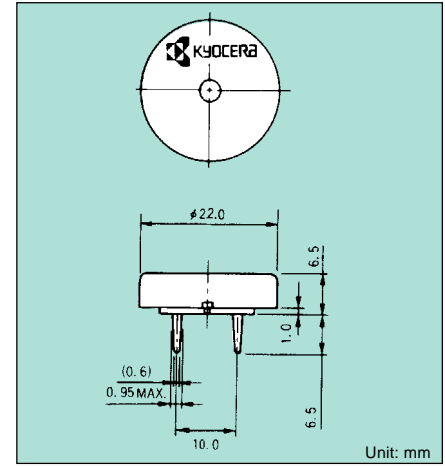

KBS-15DB-4A

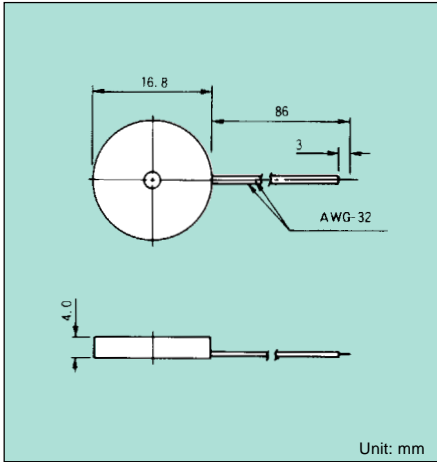

KBS-20DB-4A-22

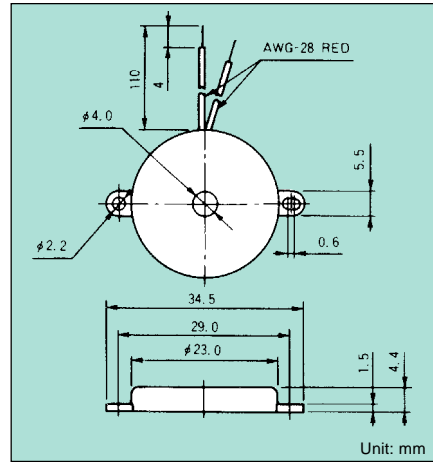

KBS-20DB-5A

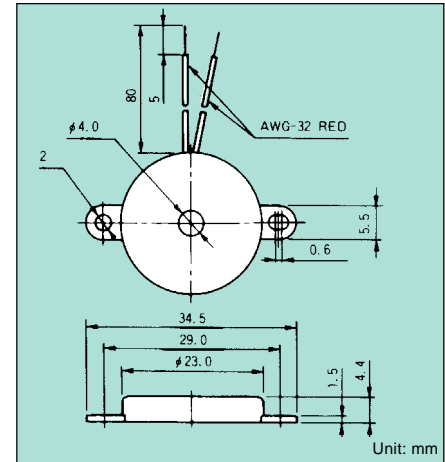

KBS-27DB-2A-5

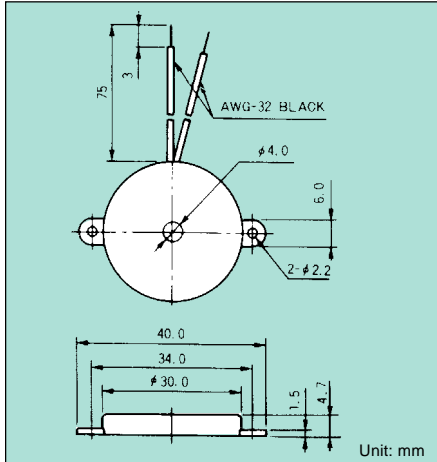

KBS-27DB-3A

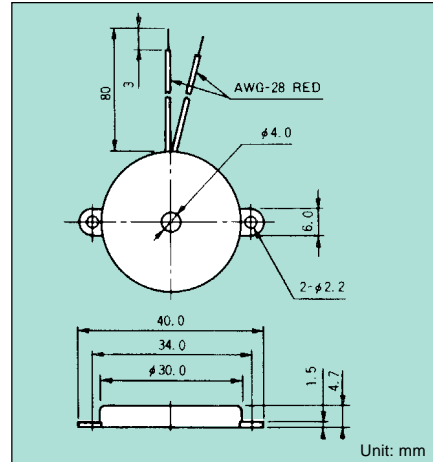

Tweeter Type -KBS-XX-XA/ZA

Features:

- 1) Compact, thin, highly efficient
- 2) Lower power consumption
- 3) Lightweight
- 4) Generate no magnetic flux
- 5) High reliability

Applications:

- 1) Tweeter
- 2) Car audio speakers

How To Order:

KBS - 21 XA - 4 A _____

- ① Model
- ② Diameter (mm) eg. 21
- ③ Element Shape
XA = Unimorph
ZA = Bimorph
- ④ Resonant Frequency: eg. 4
- ⑤ 2-Terminal Electrode Type
- ⑥ Disc Material
Blank = Brass

Dimensions

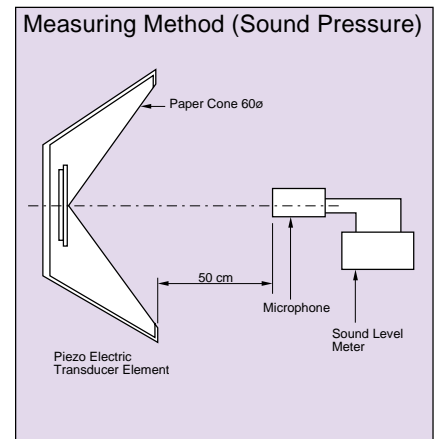
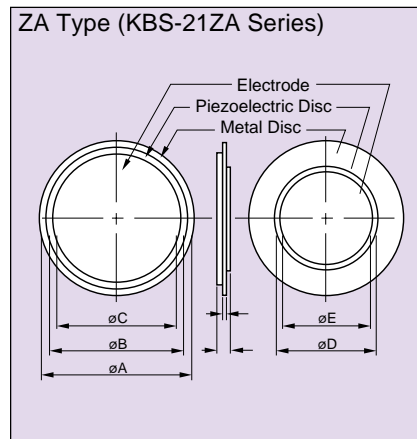
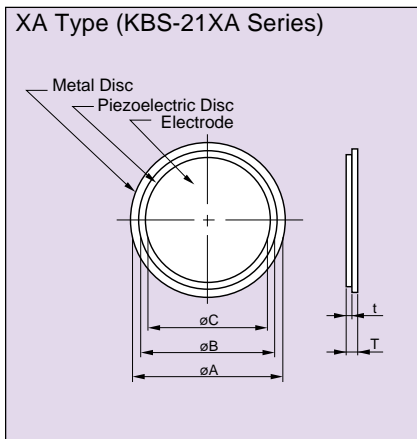

Characteristics

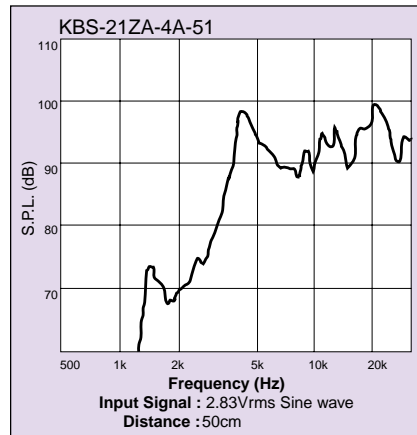
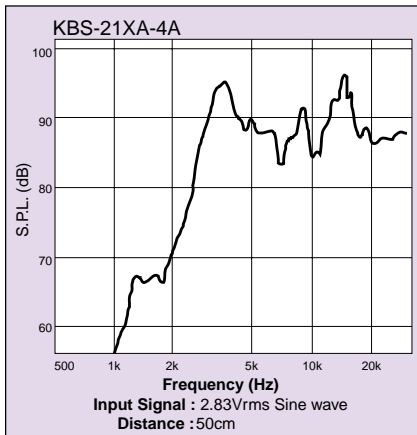

Tweeter Type

Specifications (XA type)

Model No.	Resonant Frequency (kHz)	Resonant Impedance (Ω)	Static Capacitance (pF)	Dimensions (mm)					Metal Disc Material
				Metal Disc (ϕ A)	Ceramic Disc (ϕ B)	Electrode (ϕ C)	Total Thickness (T)	Metal Disc Thickness (t)	
KBS-21XA-4A	3.6 \pm 0.6	150	90,000 \pm 30%	21.0 \pm 0.1	20.2 \pm 0.3	(19.0)	0.28 \pm 0.1	0.15 \pm 0.03	Brass
KBS-27XA-2A	1.8 \pm 0.5	150	123,000 MIN.	27.0 \pm 0.1	25.0 \pm 0.5	(23.5)	0.28 \pm 0.1	0.15 \pm 0.03	Brass

(ZA type)

Model No.	Resonant Frequency (kHz)	Resonant Impedance (Ω)	Static Capacitance (pF)	Dimensions (mm)					Metal Disc Material
				Metal Disc (ϕ A)	Ceramic Disc	Electrode	Total Thickness (T)	Metal Disc Thickness (t)	
					Upper (ϕ B)	Upper (ϕ C)			
KBS-18ZA-7A	6.8 \pm 1.0	100	125,000 \pm 30%	18.0 \pm 0.1	16.8 \pm 0.3	(16.0)	0.32 \pm 0.1	0.10 \pm 0.03	Brass
					16.8 \pm 0.3	(16.0)			
KBS-21ZA-4A-51	3.9 \pm 1.0	100	150,000 MIN.	21.0 \pm 0.1	20.2 \pm 0.3	(19.0)	0.33 \pm 0.1	0.10 \pm 0.03	Brass
					20.2 \pm 0.3	(19.0)			

Piezo Ringers

KBT-34SB-1A-0

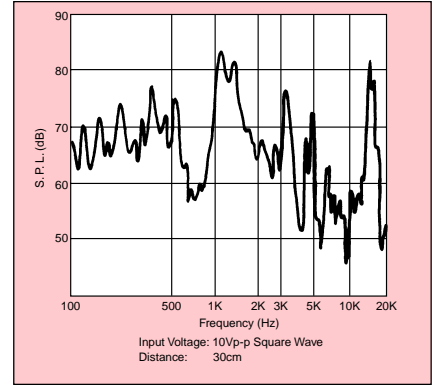
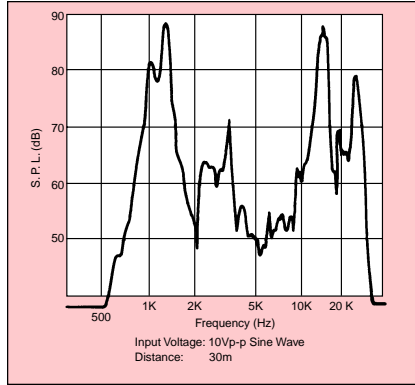
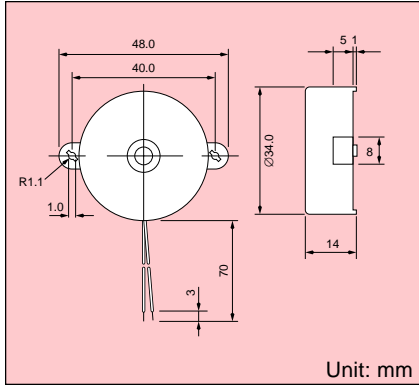

KBT-34SB-1T-0

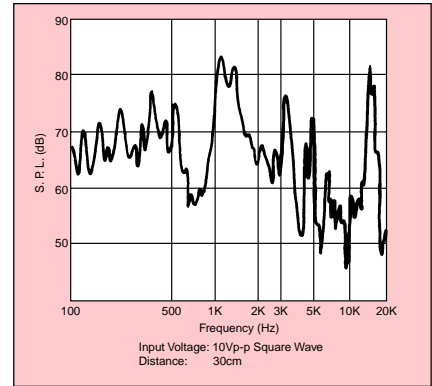
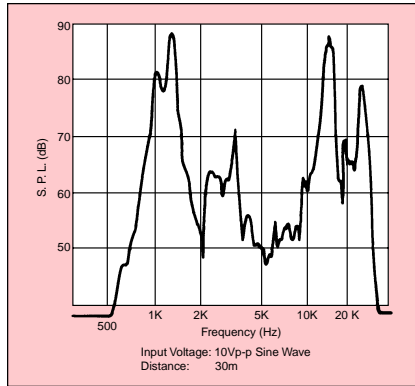
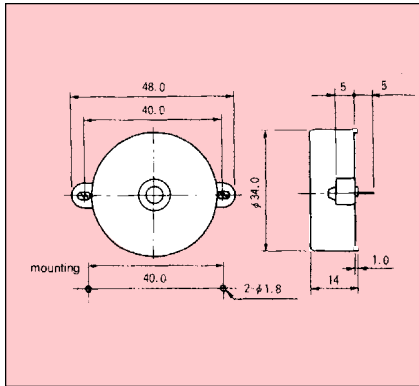

KBT-44SB-1A

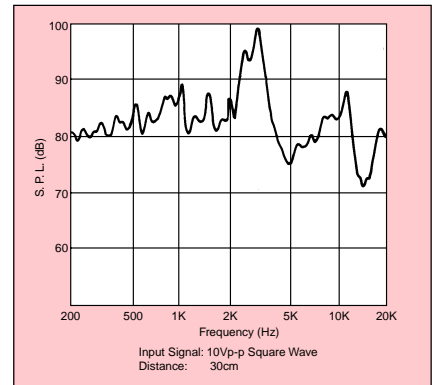
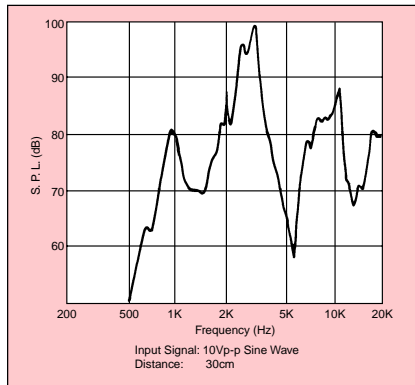
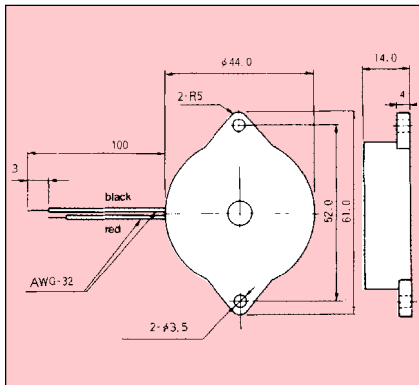

KBS-50DL-05C

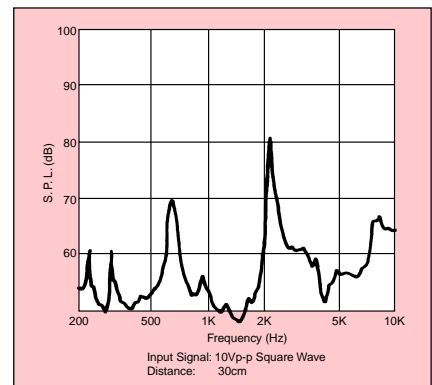
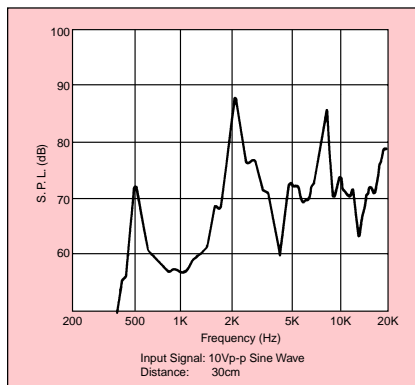
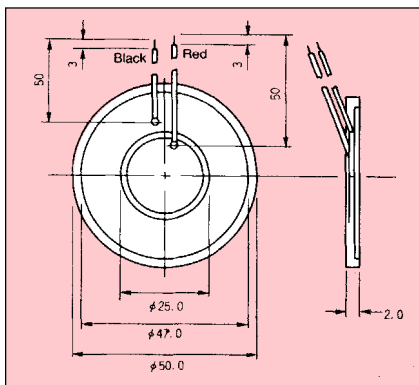

Magnetic Receivers - PCRT Series

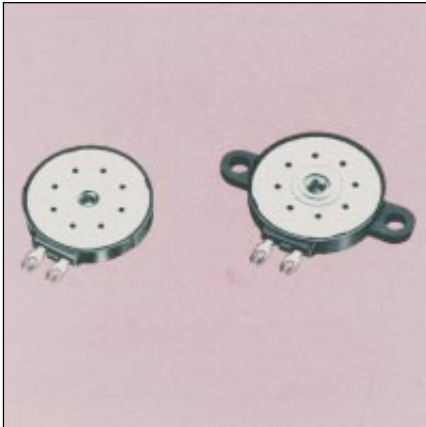

Features:

- 1) Compact and light weight
- 2) High sound quality and high S.P.L.
- 3) Hearing aid compatible (HAC)
- 4) Anti-shock, anti-vibration design

Applications:

- 1) Telecommunications
- 2) Cordless and cellular telephones (HAC)

How To Order:

PCRT 21 A S X

- ① Model
- ② Diameter in mm (20 or 21)
- ③ Impedance (A:150Ω, B:32Ω)
- ④ Op. Temp. (S:10~50°C, G:-20~60°C)
- ⑤ Shape
 - X = ø21 round shape
 - S = ø20 round shape
 - E = ø21 with flanges

Electrical Characteristics

P/N	S.P.L.	Input Impedance	Magnetic Flux Density	
			Axial Direction	Radial Direction
PCRT20ALS	100±3dB	150Ω±20%	-19dB min. (0.1VRMS, 1kHz)	-27dB min. (0.1VRMS, 1kHz)
PCRT21ASX	93±3dB (0.1V RMS, 1kHz) (IEC318, Coupler)	150Ω±15% (1kHz)		
PCRT21BSX	100±3dB	32Ω±15%		

Dimensions

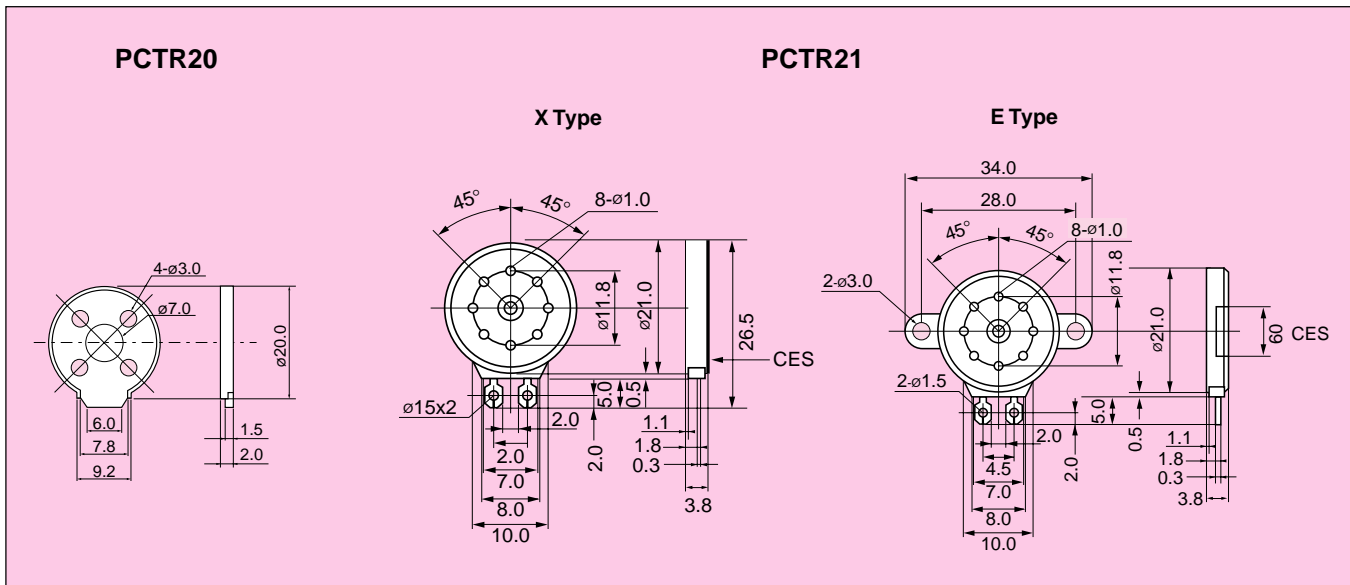

Magnetic Receivers - PCRT Series

PCRT21 Recommended Earpiece

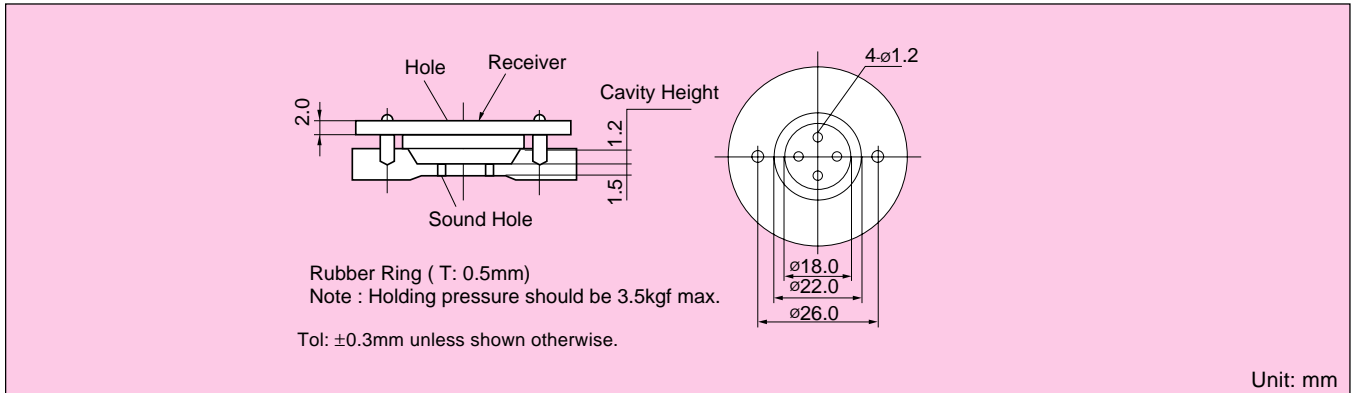

S.P.L. Test Circuit

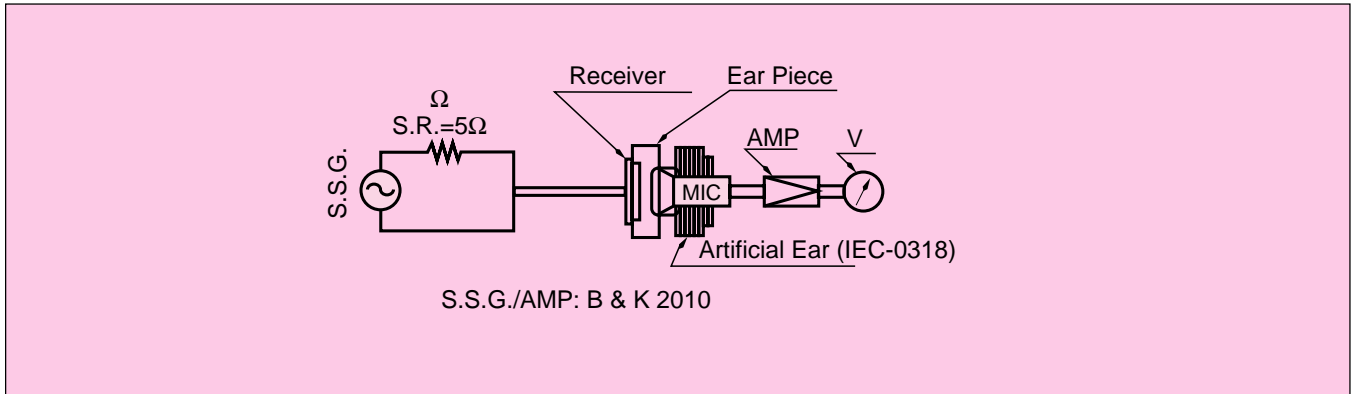

Piezoelectric Acoustic Generators

Ceramic Receivers



Features:

- 1) Excellent acoustic characteristics
- 2) High durability (shock, thermal)
- 3) Small and thin shape
- 4) Low current consumption
- 5) Low cost

Applications:

- 1) Multiple function telephone
- 2) Push button telephone
- 3) Cordless phone
- 4) Portable phone
- 5) Mobile phone

How To Order:

KBT - 33 - RB - 2CN - 0

- ① ② ③ ④ ⑤
- ① Model
 - ② Diameter
 - ③ Ceramic Receiver
 - ④ Type: CN
 - ⑤ Spec Number (if modified specification is used)

Specifications

Model	KBT-33RB-2S
Sound Pressure Level	107 ± 3dB (1Vrms, IEC318) 1KHz
Capacitance	60nF ± 25% (120Hz)
Impedance	2.8 KΩ ± 25% (1KHz)
Connection	Wire (AWG #32) UL1571

Earpiece (Recommended)

In order to obtain optimum ceramic receiver characteristics, the earpiece construction should be as shown below.

KBT-33RB-2CN-0

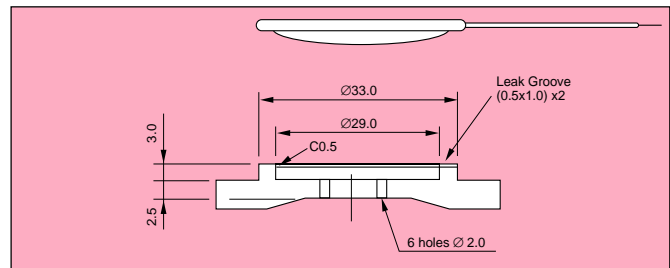

Measurement of S.P.L.

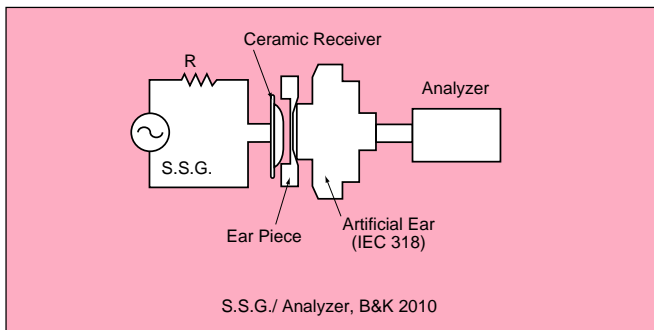

Impedance Curve

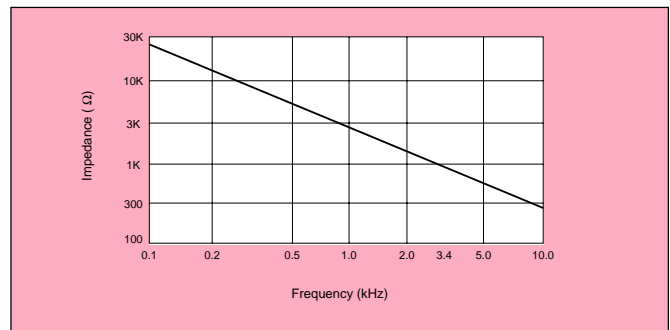

Dimensions

KBT-33RB-2CN-0

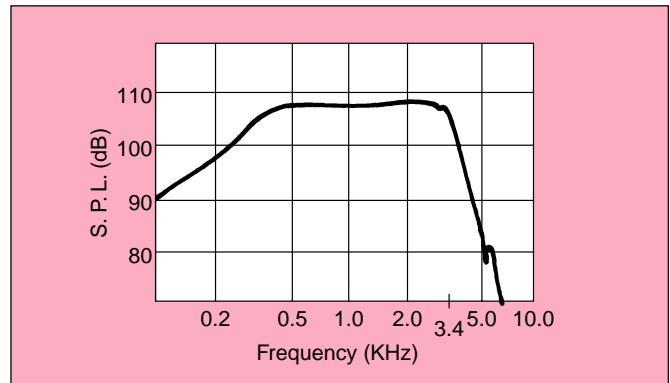
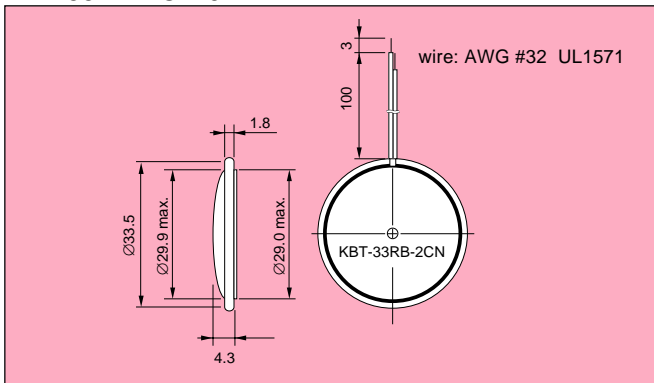

USA

AVX, Myrtle Beach, SC

CORPORATE OFFICES
Tel: 803-448-9411
Fax: 803-448-1943

AVX, Vancouver, WA

Tel: 206-696-2840
Fax: 206-695-5836

AVX, Olean, NY

Tel: 716-372-6611
Fax: 716-372-6316

AVX, Raleigh, NC

Tel: 919-878-6200
Fax: 919-878-6462

AVX, Biddeford, ME

Tel: 207-282-5111
Fax: 207-283-1941

AVX, Colorado Springs, CO

Tel: 719-576-3510
Fax: 719-576-3814

AVX, Sun Valley, CA

Tel: 818-767-6770
Fax: 818-767-3527

EUROPE

AVX Limited, England

Tel: ++44 (0)1252 770000
Fax: ++44 (0)1252 770001

AVX S.A., France

Tel: ++33 (1) 69.18.46.00
Fax: ++33 (1) 69.28.73.87

AVX GmbH, Germany—Elco

Tel: ++49 (0) 2741 2990
Fax: ++49 (0) 2741 299133

AVX GmbH, Germany—AVX

Tel: ++49 (0) 8131 90040
Fax: ++49 (0) 8131 90044

AVX srl, Italy

Tel: ++39 (0)2 665 00116
Fax: ++39 (0)2 614 2576

AVX Ltd., Israel

Tel: ++972 (0)957 3873
Fax: ++972 (0)9957 3853

AVX sro, Czech Republic

Tel: ++420 (0)467 558340
Fax: ++420 (0)467 2844

ASICA-PACIFIC

AVX/Kyocera, Singapore

Tel: (65) 258-2833
Fax: (65) 258-8221

AVX/Kyocera, Hong Kong

Tel: (852) 2-363-3303
Fax: (852) 2-765-8185

AVX/Kyocera, Korea

Tel: (82) 2-785-6504
Fax: (82) 2-784-5411

AVX/Kyocera, Taiwan

Tel: (886) 2-516-7010
Fax: (886) 2-506-9774

AVX/Kyocera, Shanghai

Tel: (86) 21-6249-0314-16
Fax: (86) 21-6249-0313

AVX/Kyocera, Malaysia

Tel: (60) 4-228-1190
Fax: (60) 4-228-1196

AVX/Kyocera, Japan

Tel: (81) 75-592-3897
Fax: (81) 75-501-4936

Contact:

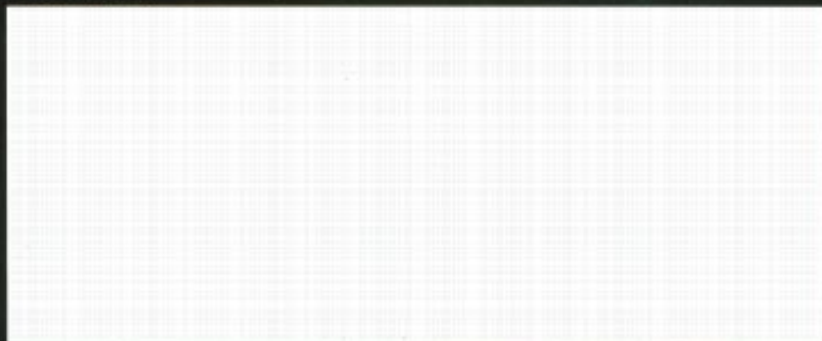

AVX