

APPLICATION NOTE 3300

Interfacing I2C Serial Real-Time Clocks to a Microcontroller

This application note describes a general hardware configuration and example software for the Dallas I²C interface Real-Time Clocks. This example is specifically written for RTCs that use a BCD time and date format.*

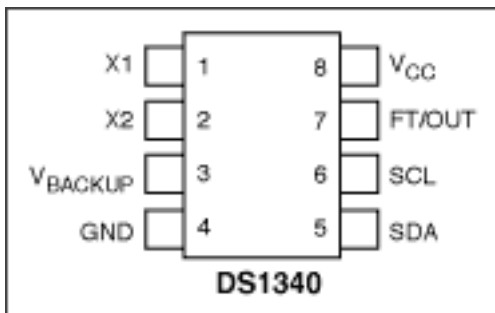

Pin Assignment

Description

This application note describes the general hardware configuration and basic software communication examples for the Dallas I²C serial-interface Real-Time Clocks (RTC). The devices covered are the BCD-format I²C clocks: DS1307, DS1337, DS1338, DS1339 and DS1340. The DS1375 could also be supported, if circuit modifications were made to provide a digital clock signal (32,768Hz, 8,192Hz, 60Hz, or 50Hz) to the CLK input pin. The microcontroller used for this example is the DS2250, and the example software is written in C.

A schematic of the circuit is shown in **Figure 1**. The schematic shows connections for a DS1340. The other RTCs may require modifications. The DS1337, for example, replaces the battery back up input with an additional interrupt output. The low voltage versions of the RTCs would require replacing the DS2250/DS5000 with a suitable low-voltage microcontroller. **Figure 2** shows the software listing. The #define directive is used to conditionally compile the code for the proper device. The example shown is for the DS1307. The #define statement for the DS1307 should be replaced with the correct device before compiling the code.

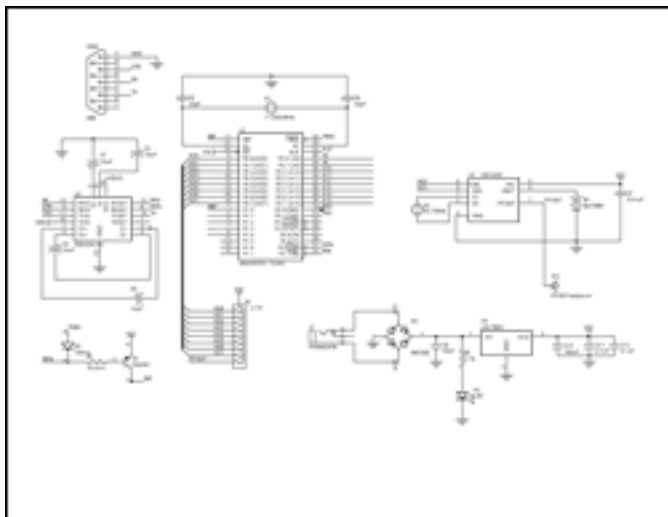

[For Larger Image](#)

Figure 1. DS1340-Microcontroller schematic.

Figure 2. Software Listing

```
/* ***** */
/* DEMO1307.c */
/* program example for DS1307, DS1337/38/39/40 */
/* ***** */
#include          /* Prototypes for I/O functions */
#include          /* Register declarations for DS5000 */
/* ***** Defines ***** */
#define ACK      0
#define NACK     1
#define ADDRTC  0xd0 /* I2C slave address */
#define DS1307  /* compile directive, modify as required */
/* ***** bit definitions ***** */
sbit scl = P0^0; /* I2C pin definitions */
sbit sda = P0^1;
sbit sqw = P3^2; /* pin function depends upon device */

/* General Notes: Define one device to compile options for that device. */
/* Will not compile correctly if no device is defined. Not all options */
/* for each device are supported. There is no error checking for data */
/* entry. Defines may not remove all code that is not relevant to the */
/* device. This example was written for an 8051-type micro, the DS2250/ */
/* DS5000. The program must be modified to work properly on typical */
/* 8051 variants (i.e. assign I2C bus to unused port pins). This */
/* program is for example only and is not supported by Dallas Maxim */

void I2C_start();
void I2C_stop();
void I2C_write(unsigned char d);
uchar I2C_read(uchar);
void readbyte();
void writebyte();
void initialize();
void disp_clk_regs(uchar);
void burstramwrite(uchar);
void burstramread();
void alm_int();
void alm_read();
void tc_setup();
/* global variables */
uchar sec, min, hr, dy, dt, mn, yr;
void I2C_start() /* ----- */
{
    sda = 1; scl = 1; /* Initiate start condition */
    sda = 0;
}
void I2C_stop() /* ----- */
{
    sda = 0; sda = 0; sda = 0; sda = 0; /* Initiate stop condition */
    scl = 1; scl = 1; sda = 1;
}
void I2C_write(uchar d) /* ----- */
{
    uchar i;
```

```

scl = 0;
for (i = 1; i <= 8; i++)
{
    sda = (d >> 7);
    scl = 1;
    d = d << 1;    /* increase scl high time */
    scl = 0;
}
sda = 1;    /* Release the sda line */
scl = 0;
scl = 1;
if(sda) printf("Ack bit missing  %02X
", (unsigned int)d);
scl = 0;
}
uchar I2C_read(uchar b) /* ----- */
{
uchar d, i;

sda = 1;    /* Let go of sda line */
scl = 0;
for (i = 1; i <= 8; i++)    /* read the msb first */
{
    scl = 1;
    d = d << 1;
    d = d | (unsigned char)sda;
    scl = 0;
}
sda = b;    /* Hold sda low for acknowledge */

scl = 0;
scl = 1;
if(b == NACK)    sda = 1;    /* sda = 1 if next cycle is reset */
scl = 0;

sda = 1;    /* Release the sda line */
return d;
}
void readbyte() /* -- read one byte of data from the specified address -- */
{
uchar Add;
printf("
ADDRESS: ");    /* Get Address */
scanf("%bx", &Add);
I2C_start();
I2C_write(ADDRTC);
I2C_write(Add);
I2C_start();
I2C_write(ADDRTC | 1);
printf("%2bx", I2C_read(NACK) );
I2C_stop();
}
void writebyte()    /* -- write one byte of data to the specified address -- */
{
uchar Add;
uchar Data;
printf("
Address: ");    /* Get Address */
scanf("%bx", &Add);

```

```

    printf("DATA: ");
    scanf("%bx", &Data); /* and data */
    I2C_start();
    I2C_write(ADDRTC);
    I2C_write(Add);
    I2C_write(Data);
    I2C_stop();
}
void initialize() /* -- initialize the time and date using entries from stdin -- */
/* Note: NO error checking is done on the user entries! */
{
    uchar yr, mn, dt, dy, hr, min, sec, day;

    I2C_start(); /* The following Enables the Oscillator */
    I2C_write(ADDRTC); /* address the part to write */
    I2C_write(0x00); /* position the address pointer to 0 */
    I2C_write(0x00); /* write 0 to the seconds register, clear the CH bit */
    I2C_stop();

    printf("
Enter the year (0-99): ");
    scanf("%bx", &yr);
    printf("Enter the month (1-12): ");
    scanf("%bx", &mn);
    printf("Enter the date (1-31): ");
    scanf("%bx", &dt);
    printf("Enter the day (1-7): ");
    scanf("%bx", &dy);
    printf("Enter the hour (1-23): ");
    scanf("%bx", &hr);
    hr = hr & 0x3f; /* force clock to 24 hour mode */
    printf("Enter the minute (0-59): ");
    scanf("%bx", &min);
    printf("Enter the second (0-59): ");
    scanf("%bx", &sec);

    I2C_start();
    I2C_write(ADDRTC); /* write slave address + write */
    I2C_write(0x00); /* write register address, 1st clock register */
    I2C_write(sec);
    I2C_write(min);
    I2C_write(hr);
    I2C_write(dy);
    I2C_write(dt);
    I2C_write(mn);
    I2C_write(yr);

#ifdef DS1307 || defined DS1338
{
    I2C_write(0x10); /* enable sqwe, 1Hz output */
}
#elif defined DS1337 || defined DS1339
{
    I2C_start();
    I2C_write(ADDRTC); /* write slave address + write */
    I2C_write(0x0e); /* write register address, control register */
    I2C_write(0x20); /* enable osc, bbsqi */
    I2C_write(0); /* clear OSF, alarm flags */
}

```

```

        /* could enable trickle charger here */
    }
#ifdef DS1340
{
    I2C_write(0x10);        /* enable sqwe, 1Hz output */
    I2C_start();           /* address pointer wraps at 7, so point to flag register */
    I2C_write(ADDRTC);     /* write slave address + write */
    I2C_write(0x09);       /* write register address, control register */
    I2C_write(0);          /* clear OSF */
}
#endif

    I2C_stop();

}

void    disp_clk_regs(uchar prv_sec)    /* ----- */
{
    uchar Sec, Min, Hrs, Dte, Mon, Day, Yr, mil, pm;

    printf("
Yr Mn Dt Dy Hr:Mn:Sc");

    while(!RI)    /* Read & Display Clock Registers */
    {
        I2C_start();
        I2C_write(ADDRTC);    /* write slave address + write */
        I2C_write(0x00);      /* write register address, 1st clock register */
        I2C_start();
        I2C_write(ADDRTC | 1); /* write slave address + read */
        Sec = I2C_read(ACK);    /* starts w/last address stored in register pointer */
        Min = I2C_read(ACK);
        Hrs = I2C_read(ACK);
        Day = I2C_read(ACK);
        Dte = I2C_read(ACK);
        Mon = I2C_read(ACK);
        Yr = I2C_read(NACK);
        I2C_stop();
        if(Hrs & 0x40)
            mil = 0;
        else
            mil = 1;

        if(Sec != prv_sec)    /* display every time seconds change */
        {
            if(mil)
            {
                printf("
%02bX/%02bX/%02bX %2bX", Yr, Mon, Dte, Day);
                printf(" %02bX:%02bX:%02bX", Hrs, Min, Sec);
            }
            else
            {
                if(Hrs & 0x20)
                    pm = 'A';
                else
                    pm = 'P';
                Hrs &= 0x1f;    /* strip mode and am/pm bits */
                printf("
%02bx/%02bx/%02bx %02bx", Yr, (Mon & 0x1f), Dte, Day);
            }
        }
    }
}

```

```

                printf(" %02bx:%02bx:%02bx %cM", Hrs, Min, Sec, pm);
            }
        }
        if(prv_sec == 0xfe)    return;
        prv_sec = Sec;
    }
    RI = 0; /* Swallow keypress before exiting */
}
void burstramwrite(uchar Data) /* ----- fill RAM with data ----- */
{
uchar j;

    I2C_start();
    I2C_write(ADDRTC);        /* write slave address + write */
    I2C_write(0x08);         /* write register address, 1st RAM location */
    for (j = 0; j < 56; j++) /* write until the pointer wraps around */
    {
        I2C_write(Data);
    }
    I2C_stop();
}
void burstramread()          /* ----- */
{
uchar j;

    I2C_start();
    I2C_write(ADDRTC);        /* write slave address + write */
    I2C_write(8);             /* write register address, 1st RAM location -1*/
    I2C_start();
    I2C_write(ADDRTC | 1);    /* write slave address + read */

    for (j = 0; j < 56; j++)
    {
        if(!(j % 16)) printf("
%02bx ", j);
        printf("%02bx ", I2C_read(ACK) );
    }
    I2C_read(NACK);
    I2C_stop();
}
void    alm_int()           /* ----- initialize alarm registers ----- */
{
uchar    M, Sec, Min, Hr, DyDt;

    printf("
1-Alarm each second
2-Alarm match=sec
3-Alarm match=sec+min");
    printf("
4-Alarm match=sec+min+hr
5-Alarm match=sec+min+hr+date");
    printf("
6-Alarm match=sec+min+hr+day
Enter selection: ");

    M = _getkey(); /* Note-No error checking is done on entries! */

    switch(M)
    {

```

```

        case '1':      M = 0xf;      break;
        case '2':      M = 0xe;      break;
        case '3':      M = 0xc;      break;
        case '4':      M = 8;        break;
        case '5':      M = 0;        break;
        case '6':      M = 0x40;     break;
    }
    if(M & 0x40)
    {
        printf("
Enter the day (1-7): ");
        scanf("%bx", &DyDt);
    }
    else
    {
        printf("
Enter the date (1-31): ");
        scanf("%bx", &DyDt);
    }
    printf("Enter the hour (1-23): ");
    scanf("%bx", &Hr);
    printf("Enter the minute (0-59): ");
    scanf("%bx", &Min);
    printf("Enter the second (0-59): ");
    scanf("%bx", &Sec);

    if( (M & 1) )    Sec |= 0x80;
    if( ((M >> 1) & 1) )    Min |= 0x80;
    if( ((M >> 2) & 1) )    Hr |= 0x80;
    if( ((M >> 3) & 1) )    DyDt |= 0x80;
    if(M & 0x40)    DyDt |= 0x40;

    I2C_start();
    I2C_write(ADDRTC);      /* write slave address + write */
    I2C_write(7);          /* write register address */
    I2C_write(Sec);
    I2C_write(Min);
    I2C_write(Hr);
    I2C_write(DyDt);
    I2C_start();
    I2C_write(ADDRTC);      /* write slave address + write */
    I2C_write(0x0e);        /* write register address */
    I2C_write(5);          /* enable interrupts, alarm 1 */
    I2C_stop();
}
void alm_read()          /* ----- read alarm registers ----- */
{
    uchar Sec, Min, Hr, DyDt;

    I2C_start();
    I2C_write(ADDRTC);      /* write slave address + write */
    I2C_write(7);          /* write register address */
    I2C_start();
    I2C_write(ADDRTC | 1); /* write slave address + read */
    Sec = I2C_read(ACK);
    Min = I2C_read(ACK);
    Hr = I2C_read(ACK);
    DyDt = I2C_read(NACK);
}

```

```

        printf("
Alarm 1: %02bx %02bx %02bx %02bx", Sec, Min, Hr, DyDt);
    }
void    tc_setup()        /* ---- trickle charger set up routine ---- */
{
uchar   M, val;

#ifdef DS1339
    #define TC 0x10 /* address for DS1339 trickle charge register */
#else
    #define TC 0x08 /* address for DS1340 trickle charge register */
#endif

    printf("
Enable Trickle Charger (Y/N)? ");
    M = _getkey();

    if(M == 'Y' || M == 'y')
    {
        printf("
1-250 ohm res
2-2K res=sec
3-4K res");

        M = _getkey(); /* Note-No error checking is done on entries! */

        switch(M)
        {
            case '1':        val = 1;        break;
            case '2':        val = 2;        break;
            case '3':        val = 3;        break;
        }
        printf("
1-no diode
2-1 diode");

        M = _getkey(); /* Note-No error checking is done on entries! */

        switch(M)
        {
            case '1':        val += 4;        break;
            case '2':        val += 8;        break;
        }
        I2C_start();
        I2C_write(ADDRTC);          /* write slave address + write */
        I2C_write(TC);             /* write register address */
        I2C_write(val | 0xa0);     /* enable trickle charger per user input */
        I2C_stop();
    }
    else
    {
        I2C_start();
        I2C_write(ADDRTC);          /* write slave address + write */
        I2C_write(TC);             /* write register address */
        I2C_write(0);              /* disable trickle charger */
        I2C_stop();
    }
    I2C_start();
    I2C_write(ADDRTC);             /* write slave address + write */

```



```

        I2C_write(TC);          /* write register address */
        I2C_start();
        I2C_write(ADDRTC | 1); /* write slave address + read */
        printf("
Trickle Charger: %02bx", I2C_read(NACK) );
    }
main    (void) /* ----- */
{
    uchar    M, M1;

        sqw = 1;          /* set up for read, weak pull-up */

        while (1)
        {
#ifdef DS1307
            printf("
DEMO1307 build %s
", __DATE__);
#elif defined DS1337
            printf("
DEMO1337 build %s
", __DATE__);
#elif defined DS1338
            printf("
DEMO1338 build %s
", __DATE__);
#elif defined DS1339
            printf("
DEMO1339 build %s
", __DATE__);
#elif defined DS1340
            printf("
DEMO1340 build %s
", __DATE__);
#endif

            printf("CI Init RTC    CR Read Clock
");
            printf("BR Byte Read    BW Write Byte
");

#ifdef DS1337 || defined DS1339    /* only print if part has alarms */
            printf("AI Alarm 1 Int AR Alarm Read
");
#endif
#ifdef DS1340 || defined DS1339    /* parts that have trickle charger */
            printf("Tc Trickle charger
");
#endif

#ifdef DS1307 || defined DS1338    /* only print if part has RAM */
            printf("RR RAM Read    RW RAM Write
");
#endif

            printf("Enter Menu Selection:");

            M = _getkey();

            switch(M)

```

```

    {
        case 'A':
        case 'a':
        printf("
Init or Read: ");

        M1 = _getkey();

        switch(M1)
        {
            case 'I':
            case 'i':          alm_int();          break;

            case 'R':
            case 'r':          alm_read();         break;
        }
        break;

        case 'B':
        case 'b':
        printf("
Read or Write: ");

        M1 = _getkey();

        switch(M1)
        {
            case 'R':
            case 'r':          readbyte();         break;

            case 'W':
            case 'w':          writebyte();        break;
        }
        break;

        case 'C':
        case 'c':
        printf("\r\nEnter Clock Routine to run:C");
        M1 = _getkey();

        switch(M1)
        {
            case 'I':
            case 'i':          initialize();       break;

            case 'R':
            case 'r':          disp_clk_regs(0x99); break;
        }
        break;

        case 'R':
        case 'r':
        printf("\r\nEnter Ram Routine to run:R");
        M1 = _getkey();

        switch(M1)
        {
            case 'R':
            case 'r':          burstramread();     break;

            case 'W':
            case 'w':          printf("
Enter the data to write: ");

```

```
scanf("%bx", &M1);
burstramwrite(M1);      break;
}
break;

case 'T':
case 't':      tc_setup();      break;
}
}
}
```

Application Note 3300: <http://www.maxim-ic.com/an3300>

More Information

For technical questions and support: <http://www.maxim-ic.com/support>

For samples: <http://www.maxim-ic.com/samples>

Other questions and comments: <http://www.maxim-ic.com/contact>

Related Parts

DS1307: [QuickView](#) -- [Full \(PDF\) Data Sheet](#) -- [Free Samples](#)

DS1337: [QuickView](#) -- [Full \(PDF\) Data Sheet](#) -- [Free Samples](#)

DS1338: [QuickView](#) -- [Full \(PDF\) Data Sheet](#) -- [Free Samples](#)

DS1339: [QuickView](#) -- [Full \(PDF\) Data Sheet](#) -- [Free Samples](#)

DS1340: [QuickView](#) -- [Full \(PDF\) Data Sheet](#) -- [Free Samples](#)

DS1375: [QuickView](#) -- [Full \(PDF\) Data Sheet](#) -- [Free Samples](#)

AN3300, AN 3300, APP3300, Appnote3300, Appnote 3300

Copyright © 2005 by Maxim Integrated Products

Additional legal notices: <http://www.maxim-ic.com/legal>