

Elektronische Last
 50V / 20A / 200W
 Leistungsteil
 Datum: 26.08.15
 Blatt 1/3

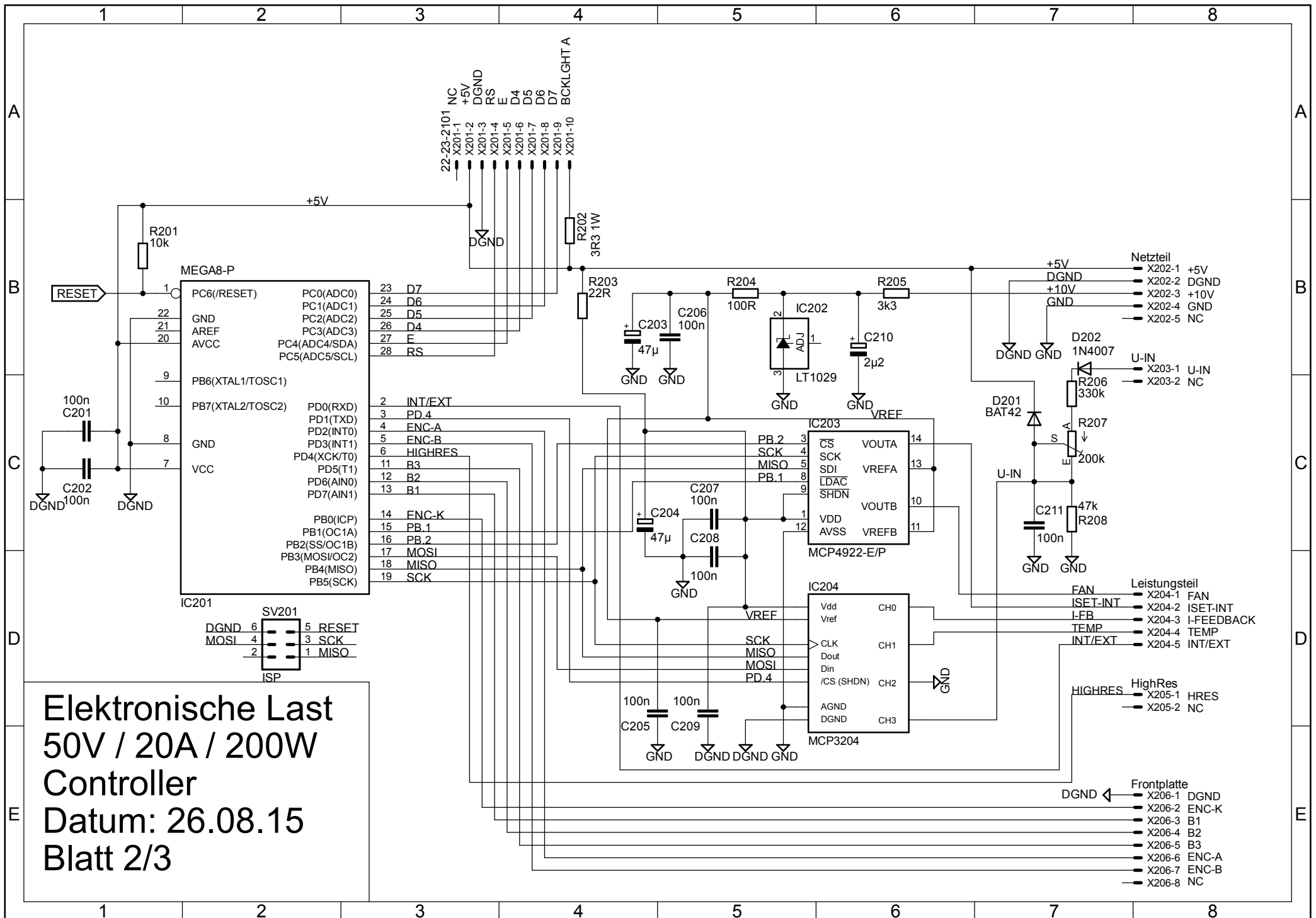

Elektronische Last
 50V / 20A / 200W
 Controller
 Datum: 26.08.15
 Blatt 2/3

- Netzteil
- X202-1 +5V
 - X202-2 DGND
 - X202-3 +10V
 - X202-4 GND
 - X202-5 NC

- U-IN
- X203-1 U-IN
 - X203-2 NC

- Leistungsteil
- X204-1 FAN
 - X204-2 ISET-INT
 - X204-3 I-FEEDBACK
 - X204-4 TEMP
 - X204-5 INT/EXT

- HighRes
- X205-1 HRES
 - X205-2 NC

- Frontplatte
- X206-1 DGND
 - X206-2 ENC-K
 - X206-3 B1
 - X206-4 B2
 - X206-5 B3
 - X206-6 ENC-A
 - X206-7 ENC-B
 - X206-8 NC

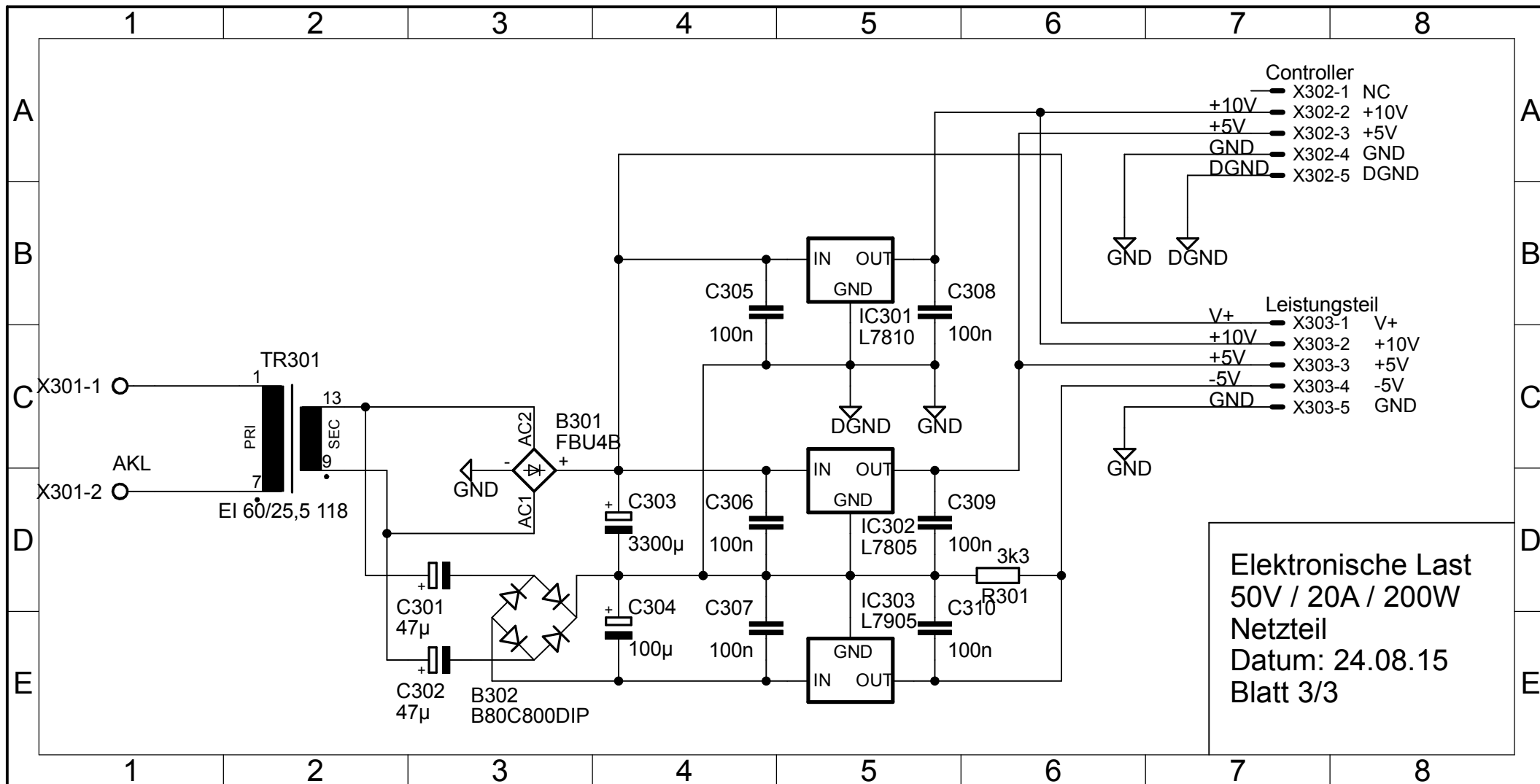

Elektronische Last
 50V / 20A / 200W
 Netzteil
 Datum: 24.08.15
 Blatt 3/3