

EVAL BOARD FOR CSI021 MEDICAL INTEGRATED CIRCUIT



KEY FEATURES

- Evaluation Board for CSI021 Aimed at Possible Neurostimulation / NeuroModulation Applications
- Contains Two Synchronizable CSI021 ICs
- Onboard Low-Power 8-bit MCU (STM-8L151G6) With Preloaded Firmware to Program CSI021
- ST-Link V2 Dongle Provided to Communicate and Program the MCU for Customization
- Onboard Adjustable Power Management Circuitry Generated From a Single Battery Voltage
- Test Points and Options Available On All Outputs for Easy Connection to External Electrodes

EB1CSI021

CSI021 Eval Board for Possible Neurostimulation / NeuroModulation Applications

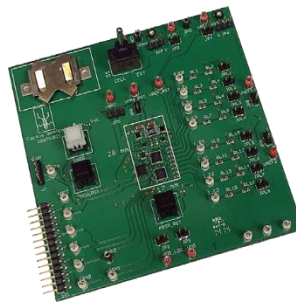

APPLICATIONS

- Neurostimulation/Neuromodulation
- Battery Powered Applications
- MEMS and Sensor Applications
- Implantable Pulse Generator/IPG

Cactus Semiconductor, Inc.

sales@cactussemi.com
1-480-497-4511

60 N. McClintock Drive, Suite 1
Chandler, AZ 85226
www.cactussemiconductor.com

GENERAL DESCRIPTION

The EB1CSI021 is designed to evaluate the CSI021, a 4-channel high voltage programmable current sink/source Application Specific Standard Product (ASSP). Evaluation requires an external power supply or a CR2016 button cell and an oscilloscope. The onboard MCU contains firmware to independently program stimulation profiles for each part. The stimulation waveforms can be easily observed on the oscilloscope. The MCU firmware can be reprogrammed to suit custom applications by using the ST-Link V2 dongle and STVD software. The software and supported documentations for the dongle and STVD software is available on the STMicroelectronics® website.

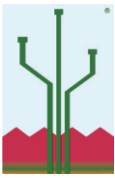

EB1CSI021

4-Channel High Voltage Programmable Current Sink/Source

Quick Setup Instructions

1. Place a CR2016 button cell (included) in the holder or apply 3V to 4V at VBAT. Use the switch S1 to choose between the button cell and an external power supply as the VBAT voltage.
2. All jumpers are configured in default positions.
3. Press the USER button once to run the preloaded MCU firmware. This will program the CSI021-0 and CSI021-1 ASSPs.
4. Observe stimulation waveforms on test points, 0_E0, 0_E1, 0_E2, 0_E3, 1_E0, 1_E1, 1_E2, and 1_E3. The stimulation profile will complete after the programmed number of pulses are executed.
5. The MCU_RST or ASSP_RST buttons can be pressed to stop the stimulation before completion.
6. If the MCU_RST button is pressed, both MCU and ASSPs are reset. Pressing the USER button will restart the stimulation profile.
7. If the ASSP_RST button is pressed, only the ASSPs are reset. To restart the stimulation profile, press the MCU_RST button, then press the USER button.

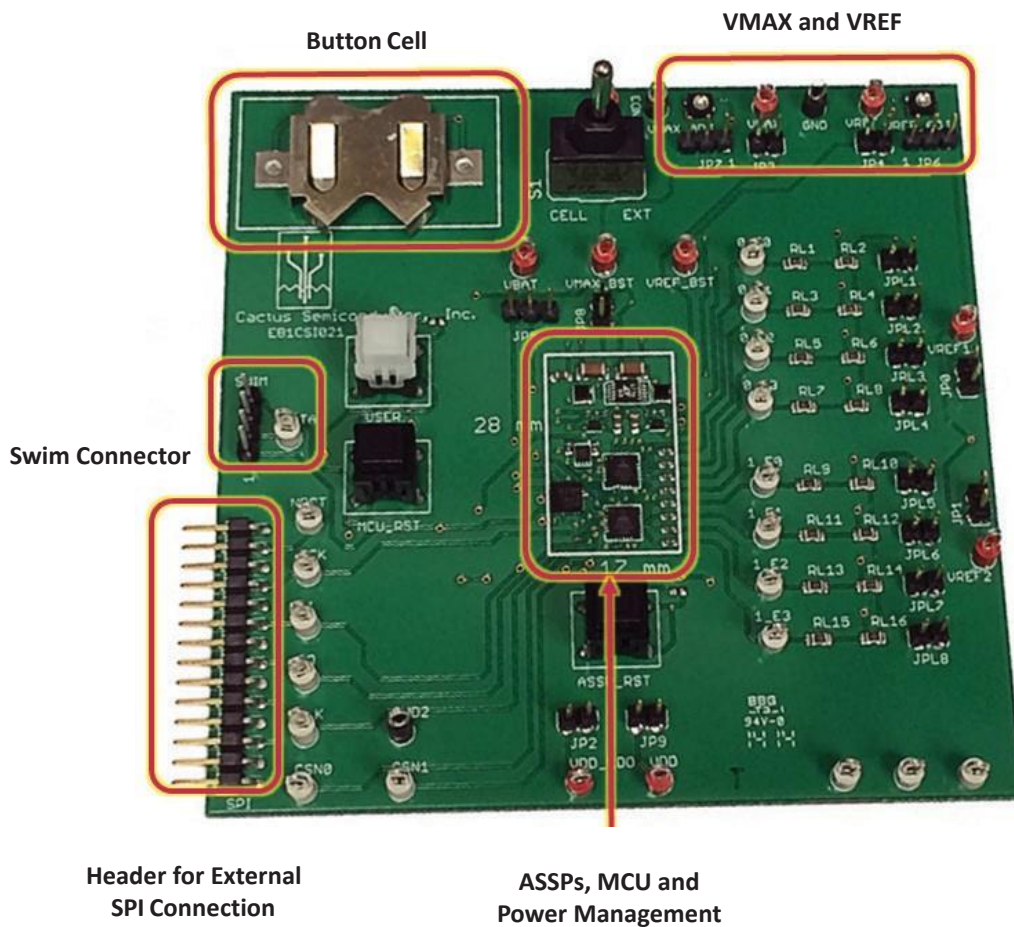

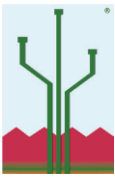

EB1CSI021

4-Channel High Voltage Programmable Current Sink/Source

TABLE OF CONTENTS

SYSTEM BLOCK DIAGRAM	4
SYSTEM OVERVIEW	4
CSI021	4
Power Supply Circuitry	5
MCU	5
BOARD SETUP	5
System Level Selections	6
MCU Connections	8
SCHEMATICS.....	9
ERRATA	13

LIST OF FIGURES

Figure 1 - System Block Diagram	4
Figure 2 - ST Link V2 Connection to EB1CSI021	8
Figure 3 - Battery and LT3009-2.5 LDO	9
Figure 4 - LT1944-1 Dual Boost for VMAX & VREF	9
Figure 5 - STM8L151G6 8-bit MCU.....	10
Figure 6 - CSI021A.....	11
Figure 7 - Silk Screen	12

LIST OF TABLES

Table 1 - Preloaded Firmware Stimulation Settings	6
Table 2 - Jumper Connections and Function	7
Table 3 - MCU Connections	8

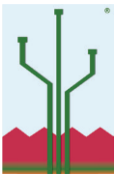

EB1CSI021

4-Channel High Voltage Programmable Current Sink/Source

SYSTEM BLOCK DIAGRAM

Figure 1 shows the system level block diagram for the EB1CSI021. The board level schematics are presented at the end of the data sheet.

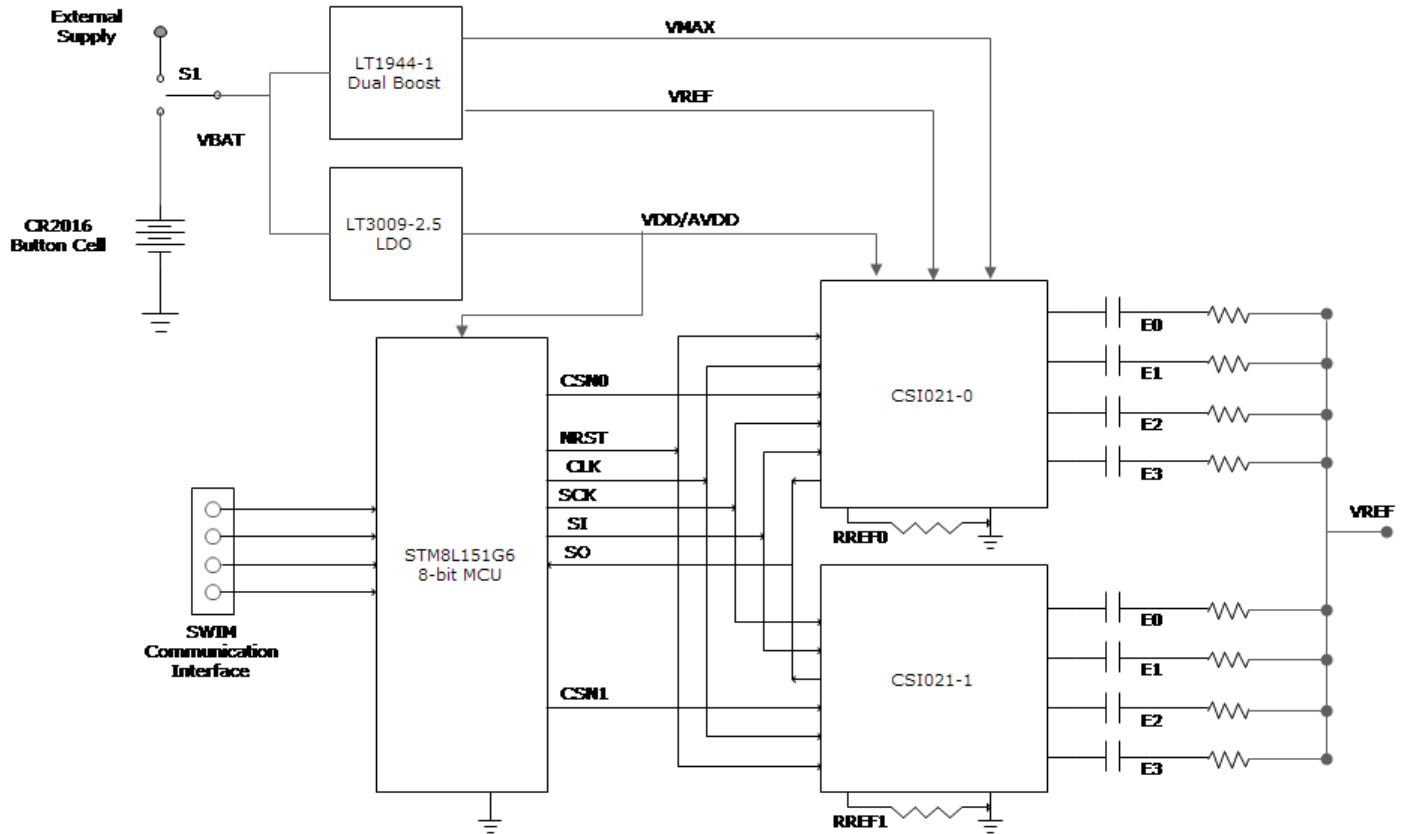
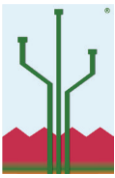

Figure 1 - System Block Diagram

SYSTEM OVERVIEW

CSI021

The EB1CSI021 contains two independently programmable CSI021 ASSPs. The CSI021 features 4 independent 8-bit linear DAC programmable current sink/source outputs with up to 6mA full-scale sink, and 1.5mA full-scale source currents. An 18V supply voltage allows for 6mA output currents into 1.5kΩ loads. The CSI021 pulse timing is fully programmable via a 1MHz (up to 10MHz), 2.5V SPI. Programmable parameters include sink/source pulse widths, pulse frequencies, stimulation on/off periods, and amplitude ramp rates. Internal timing generators in the CSI021 use the programmed parameters to create therapy profiles from a host processor. A 4:1 sink to source current ratio provides stimulation charge balancing.



EB1CSI021

4-Channel High Voltage Programmable Current Sink/Source

Power Supply Circuitry

The CSI021 ASSP operation requires a 2.5V regulated VDD/AVDD supply and two high voltage supplies of 18V (VMAX) and 12.5V (VREF). On the EB1CSI021, these supplies are generated from a 3V CR2016 button cell or a 3V-4V external source. This voltage range targets rechargeable lithium-ion batteries used in implantable applications. The VDD/AVDD voltage is generated using a LT3009-2.5 LDO. VMAX and VREF voltages are generated using an LT1944-1 Dual Micropower DC/DC Boost Converter. Both components were chosen for their low quiescent currents and small footprints. For more information about these two components, please visit Linear Technology® website at <http://www.linear.com>.

MCU

The STM8L151G6 8-bit microcontroller can be used to program the CSI021 ASSPs via SPI protocol. The MCU is preloaded with firmware that programs one of the onboard CSI021 ASSPs. The firmware code is provided on a CD and can be customized to user preferences. Communication with the MCU can be achieved by connecting the ST Link V2 01-0 dongle that is provided with the board. More information about the MCU, ST Link drivers and software to debug and program the MCU is available on the STMicroelectronics® website at <http://www.st.com>.

BOARD SETUP

The EB1CSI021 works on a single power supply. This supply can either be an onboard button cell or an external power source. The switch S1 position (CELL/EXT) determines which power source is selected. A 3V CR2016 button cell is provided with the board and can be placed in the button cell holder. With an external power source, the VBAT voltage can be set between 3V to 4V. After a VBAT voltage is applied, the LT3009-2.5 LDO is enabled and generates 2.5V, which powers the VDD/AVDD connections to the CSI021 ASSPs and the MCU. When the MCU powers up, all of its outputs are set to a high impedance state. This allows the user to externally drive the SPI and other signals to the ASSPs using LabView or a similar interface. These SPI signals are named CSN0, CSN1, SI, SO, SCK, CLK and NRST. Applying a VBAT voltage enables the LT1944-1, which sets the VMAX and VREF supplies to 18V and 12.5V, respectively.

When the USER button is pressed, the preloaded firmware on the MCU is executed. This programs the CSI021A-0 and CSI021A-1, starting the stimulation profiles. The programmed parameters for each of the channels are outlined in the table below.

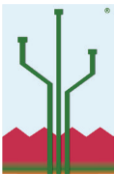

EB1CSI021

4-Channel High Voltage Programmable Current Sink/Source

Channel	Amplitude (mA)	Pulse Width (ms)	DZ0 (ms)	DZ1 (ms)	DZ2 (ms)	DZ3 (ms)	M	N	P
0_E0	1.5	1.2	1.0	4.8	655.36	0.01	4	8	255
0_E1	0.5	2.14	1.01	0.08	655.36	0.01	4	8	255
0_E2	3.0	0.1	1.03	10.24	655.36	0.01	4	8	255
0_E3	6.0	0.1	1.03	10.24	655.36	0.01	4	8	255
1_E0	1.5 (with ramp)	1.2	1.0	4.8	655.36	0.01	4	8	255
1_E1	0.5 (with ramp)	2.14	1.01	0.08	655.36	0.01	4	8	255
1_E2	3.0 (with ramp)	0.1	1.03	10.24	655.36	0.01	4	8	255
1_E3	6.0 (with ramp)	0.1	1.03	10.24	655.36	0.01	4	8	255

Table 1 - Preloaded Firmware Stimulation Settings

The stimulation profile will complete when the specified number of pulses are finished. The MCU_RST or ASSP_RST buttons can be pressed to stop the stimulation before completion. If the MCU_RST button is pressed, the MCU and ASSPs are reset. Pressing the USER button will restart the stimulation profile. If the ASSP_RST button is pressed, only the ASSPs are reset. The user must press the MCU_RST button and then press the USER button to restart the stimulation profile.

The user has the option of bypassing the MCU and programming the ASSPs directly using the available 14-pin header for the CLK, NRST and SPI pins. If the USER button is not pressed after the MCU is reset, these pins are not driven by the MCU and are in a high impedance state. These pins can be driven externally through the 14-pin header.

System Level Selections

The EB1CSI021 offers a variety of options. Jumpers on the board allow for a 1.5k Ω , 3k Ω , or an external load option to control the electrode load impedances. The VREF and VMAX supplies can be adjusted using the VREF_ADJ and VMAX_ADJ trimmer potentiometers. The voltage range on these supplies is limited to the maximum rated ASSP voltage of 18V. The user can choose to bypass the LDO and dual boost converter to apply external VDD, VMAX and VREF voltages.

The jumpers and their functions are tabulated below. The default position of the jumpers is indicated by a "D."

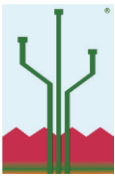

EB1CSIO21

4-Channel High Voltage Programmable Current Sink/Source

Jumper	Purpose	Position	Function	Comments
JP0	Connect VREF to CSI021A-0 load resistors	ON (D)	VREF connected	Useful for driving external loads
		OFF	VREF disconnected	
JP1	Connect VREF to CSI021A-1 load resistors	ON (D)	VREF connected	Useful for driving external loads
		OFF	VREF disconnected	
JP2	Select between onboard LDO or external VDD supply	ON (D)	Onboard 2.5V LDO	This VDD supply is connected to MCU
		OFF	External	
JP3	Select between on board or external VMAX supply	ON (D)	Onboard 18V Boost	
		OFF	External	
JP4	Select between on board or external VREF supply	ON (D)	Onboard 12.5V Boost	
		OFF	External	
JP5 (3 POS)	Select between MCU control for boost enable or boost always ON	1-2	Dual boost enable signal controlled by MCU	Boost can be controlled by MCU to duty cycle its power
		2-3 (D)	Dual boost enable connected to VBAT, always ON	
JP6 (3 POS)	Select between fixed or variable VREF supply	1-2	Variable, 3.2V to 18V	Adjust VREF using pot VREF_ADJ
		2-3 (D)	Fixed, 12.5V	
JP7 (3 POS)	Select between fixed or variable VMAX supply	1-2 (D)	Fixed, 18V	Adjust VMAX using pot VMAX_ADJ
		2-3	Variable, 3.2V to 18V	
JP8	Select 94uF or 47uF capacitance between VREF_BST and GND	ON (D)	94uF capacitance	Adjust capacitance at VREF_BST output of boost converter
		OFF	47uF capacitance	
JP9	Connect VDD of ASSPs to VDD of MCU	ON(D)	VDD for MCU & ASSPs	Flexibility to drive VDD of MCU and ASSPs separately
		OFF	External VDD for MCU	
JPL1	Select between 1.5kΩ and 3kΩ load impedance for electrode 0_E0	ON (D)	1.5kΩ load	Load selection, need 1.5kΩ load for boost mode
		OFF	3kΩ load	
JPL2	Select between 1.5kΩ and 3kΩ load impedance for electrode 0_E1	ON (D)	1.5kΩ load	Load selection, need 1.5kΩ load for boost mode
		OFF	3kΩ load	
JPL3	Select between 1.5kΩ and 3kΩ load impedance for electrode 0_E2	ON (D)	1.5kΩ load	Load selection, need 1.5kΩ load for boost mode
		OFF	3kΩ load	
JPL4	Select between 1.5kΩ and 3kΩ load impedance for electrode 0_E3	ON (D)	1.5kΩ load	Load selection, need 1.5kΩ load for boost mode
		OFF	3kΩ load	
JPL5	Select between 1.5kΩ and 3kΩ load impedance for electrode 1_E0	ON (D)	1.5kΩ load	Load selection, need 1.5kΩ load for boost mode
		OFF	3kΩ load	
JPL6	Select between 1.5kΩ and 3kΩ load impedance for electrode 1_E1	ON (D)	1.5kΩ load	Load selection, need 1.5kΩ load for boost mode
		OFF	3kΩ load	
JPL7	Select between 1.5kΩ and 3kΩ load impedance for electrode 1_E2	ON (D)	1.5kΩ load	Load selection, need 1.5kΩ load for boost mode
		OFF	3kΩ load	
JPL8	Select between 1.5kΩ and 3kΩ load impedance for electrode 1_E3	ON (D)	1.5kΩ load	Load selection, need 1.5kΩ load for boost mode
		OFF	3kΩ load	

Table 2 - Jumper Connections and Function

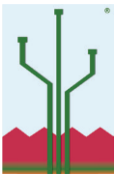

EB1CSI021

4-Channel High Voltage Programmable Current Sink/Source

MCU Connections

The STM8L151G6 8-bit MCU is used to program the CSI021 ASSP. The MCU connections to the ASSPs are shown in the table below.

Signal	MCU Port
CSN0	PB4
CSN1	PD4
SI	PB6
SO	PB7
SCK	PB5
NRST	PC3
CLK	PD2
ST_LINK	PA0
MCU_RST	PA1

Table 3 - MCU Connections

To debug and reprogram the MCU, an ST Link V2 dongle is provided with the board. This dongle communicates with the MCU using the SWIM interface. The dongle can be connected to the MCU as shown in the picture below.

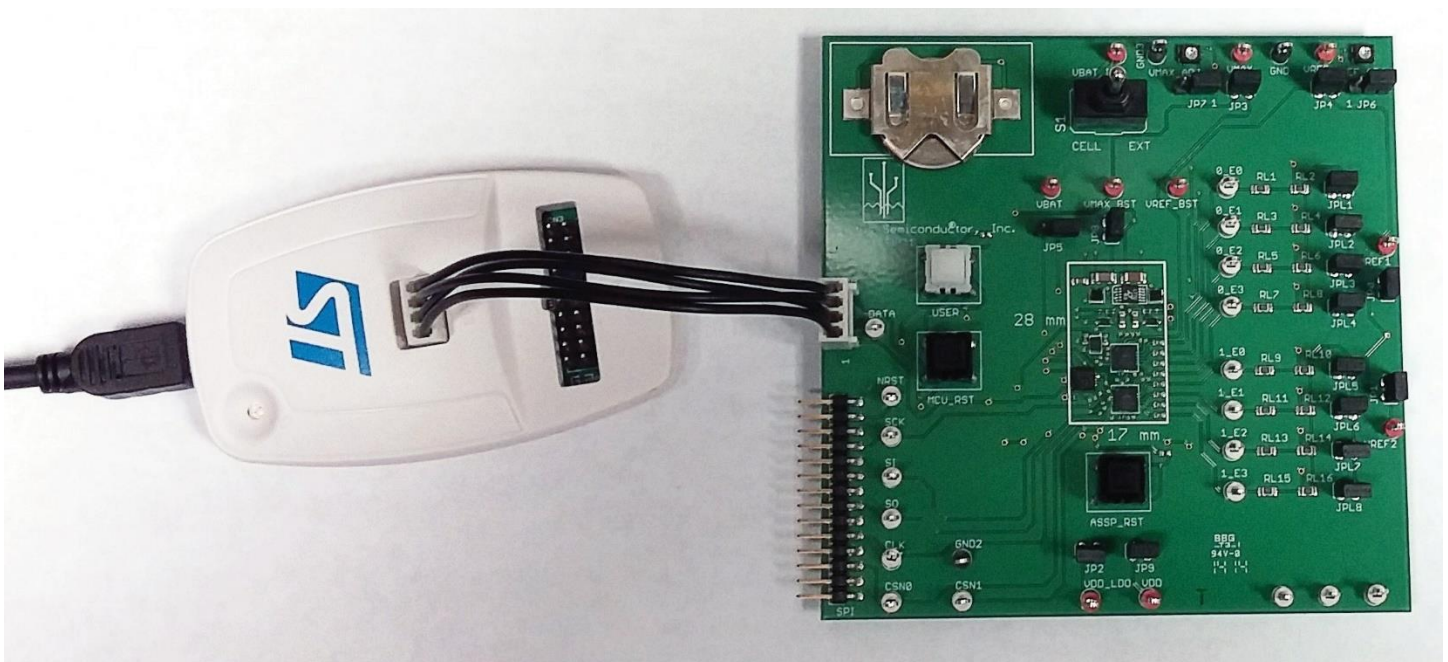
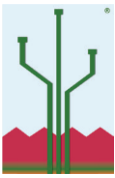

Figure 2 - ST Link V2 Connection to EB1CSI021



EB1CSI021

4-Channel High Voltage Programmable Current Sink/Source

SCHEMATICS

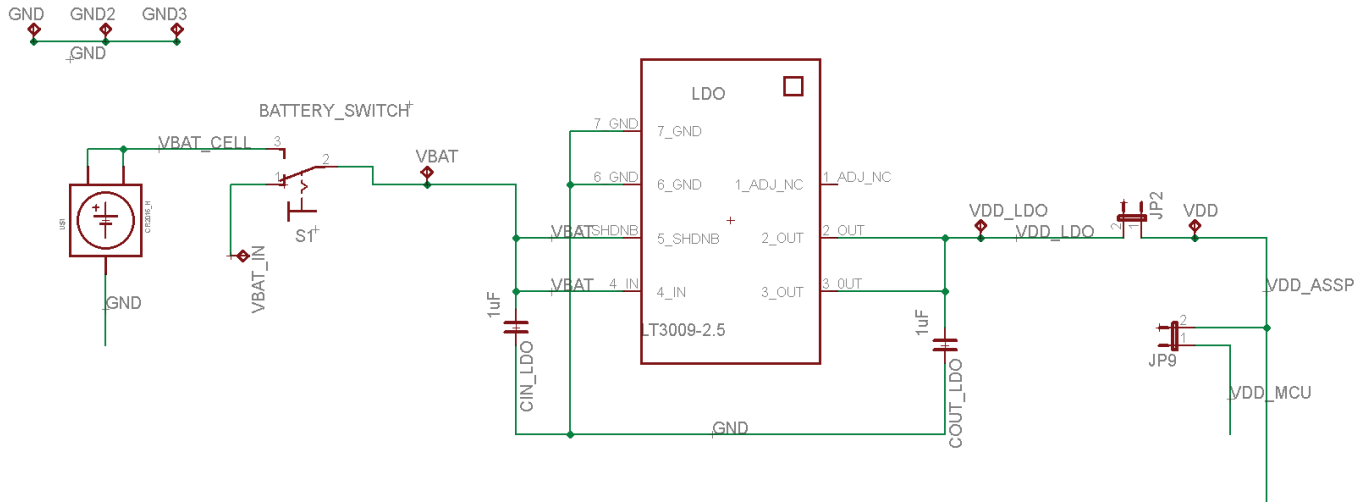

Figure 3 - Battery and LT3009-2.5 LDO

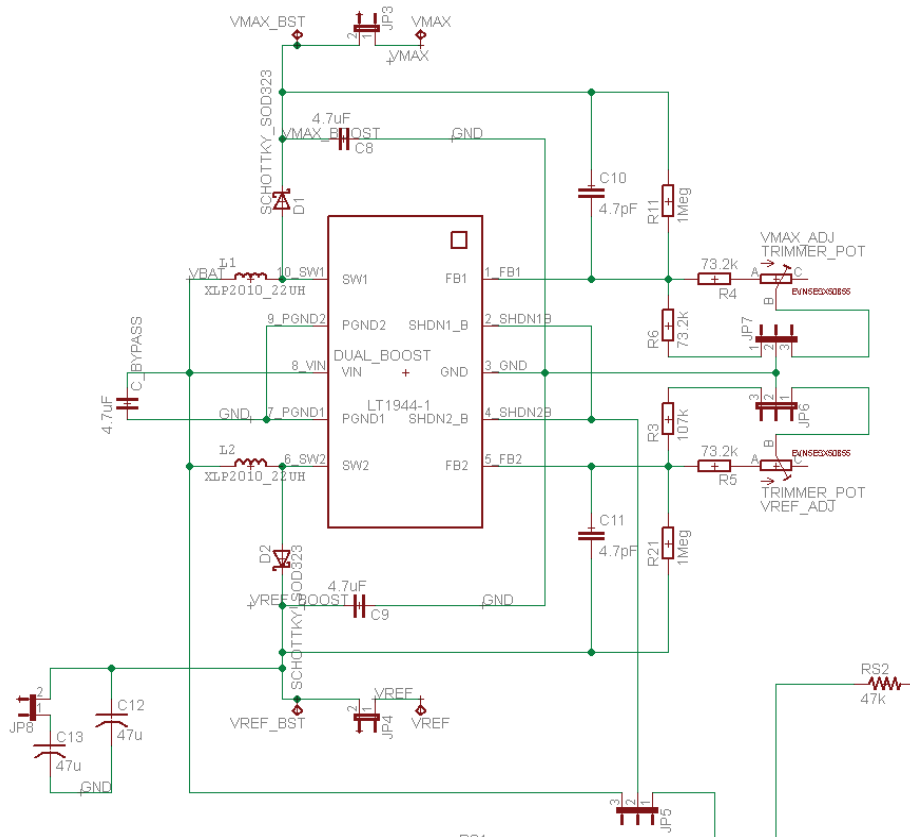
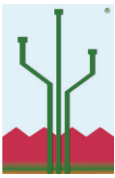

Figure 4 - LT1944-1 Dual Boost for VMAX & VREF



EB1CSI021

4-Channel High Voltage Programmable Current Sink/Source

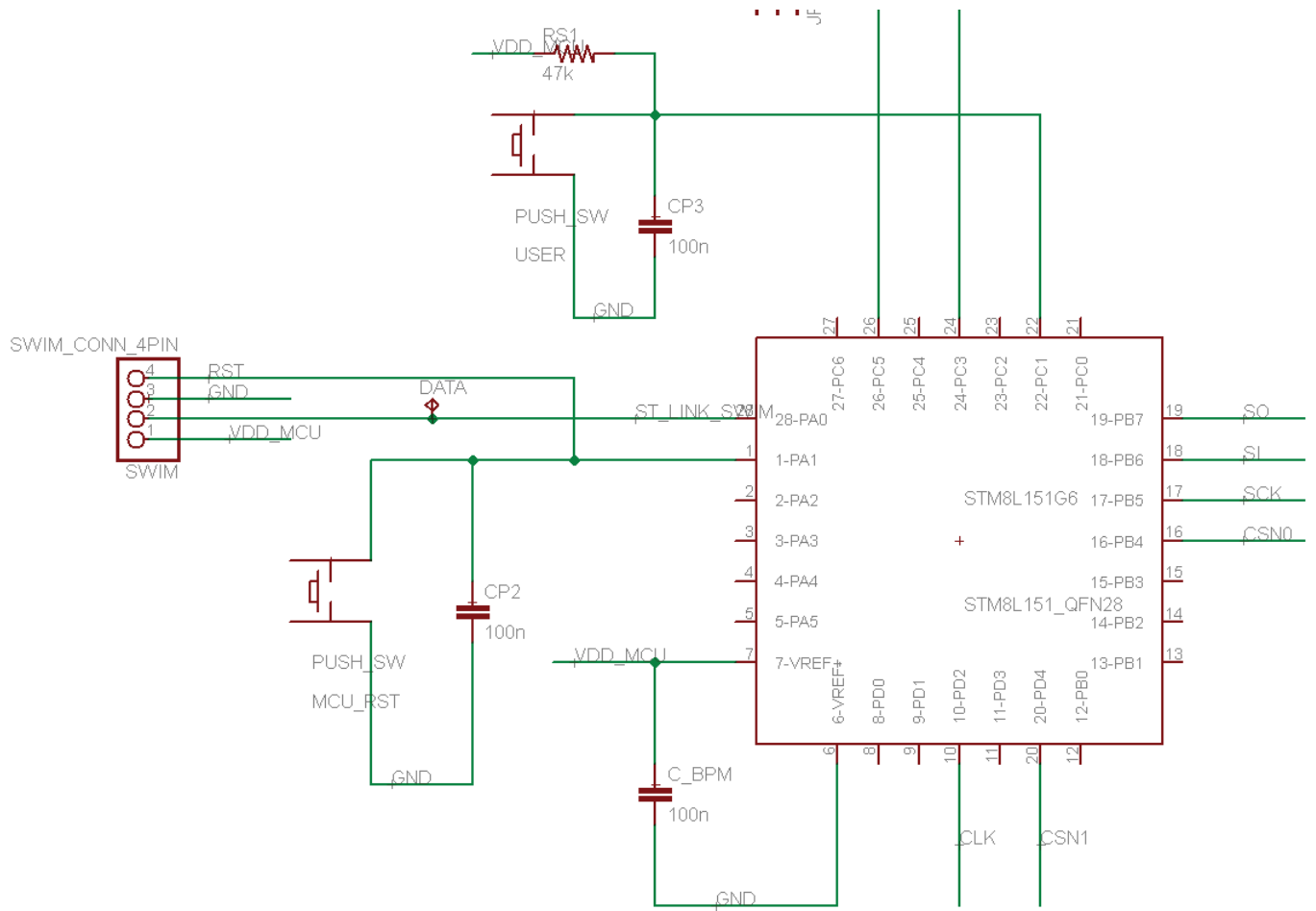
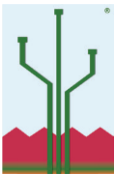

Figure 5 - STM8L151G6 8-bit MCU



EB1CSI021

4-Channel High Voltage Programmable Current Sink/Source

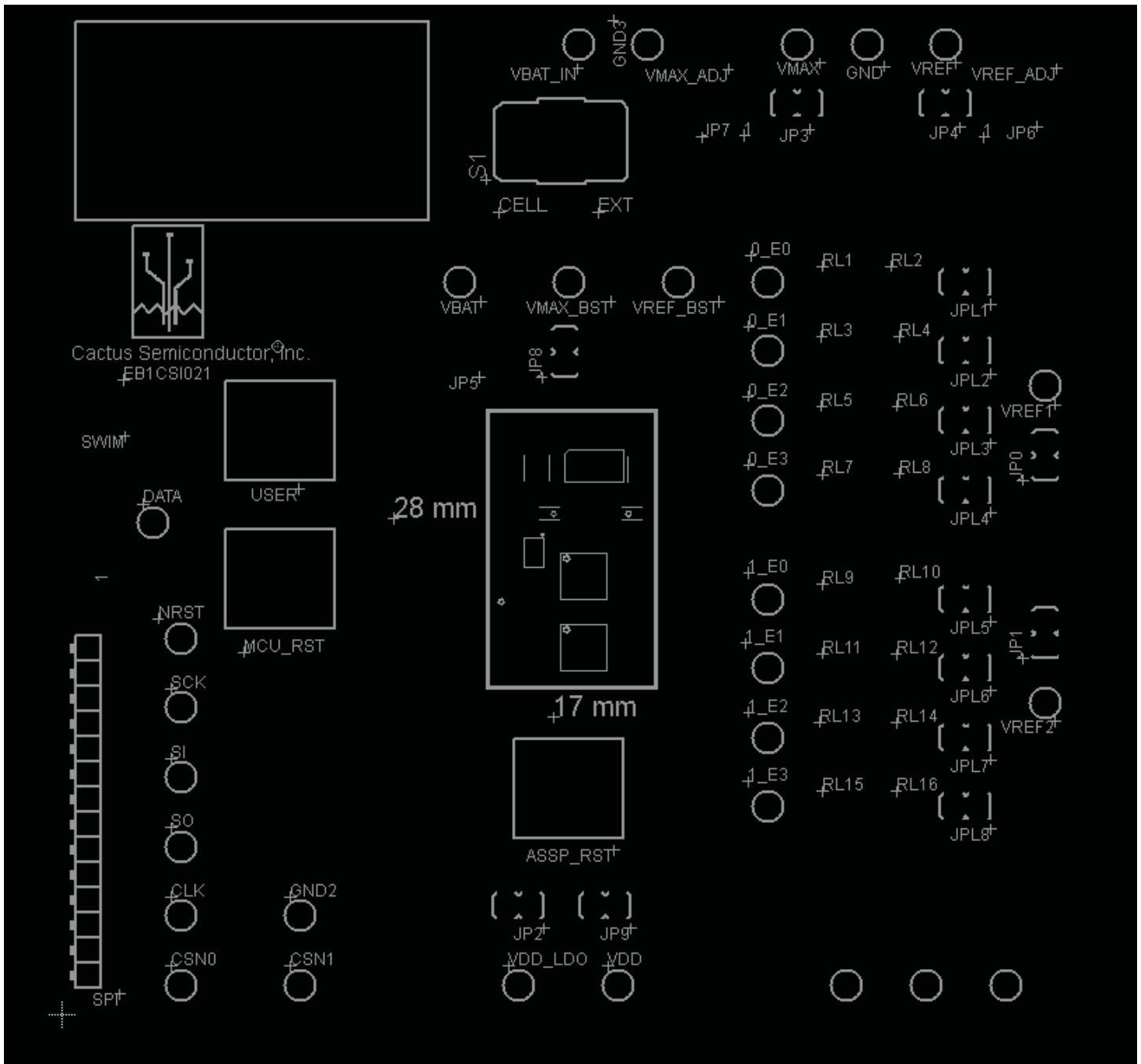
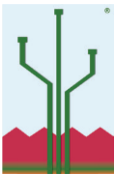

Figure 7 - Silk Screen



EB1CSI021

4-Channel High Voltage Programmable Current Sink/Source

ERRATA

1. A 100uF capacitor was added on VREF supply. During stimulation, the VREF supply is required to sink and source currents. For higher stimulation currents and simultaneous multi-channel stimulation, the boost converter can run out of regulation. The 100uF capacitor was added to demonstrate the maximum stimulation capacity. The value of this capacitor can be changed based on stimulation requirements of the application.