



3D PS/2 MOUSE CONTROLLER

General Description

The TP8472 3D Mouse Controller is specially designed to control 3D PS/2 mouse device. This single chip can interface three key-switches and six photo-couples direct to 8042. TP8472 can receive command and echo status or data format which are compatible with IBM PS/2 mode mouse and Microsoft 3D PS2 mouse. Key debouncing circuit is provided to prevent false entry and improve TP8472 accuracy.

In the conventional mouse, a great number of noises are generated when the grid is partially closed or opened. These noises are usually mistaken for movement signals by conventional mouse controller and the cursor of the display screen is thus moved frequently up and down or back and forth. This will consume a great amount of energy. The TP8472 3D PS/2 mouse controller provides noise immunity circuits to eliminate these noises in order to reduce energy consumption. Using the auto-speed adjusting circuits, TP8472 promotes the power of the mouse in movement. When TP8472 moves at low speed, it will be very smooth. While at high speed, TP8472 can change the scanning ability of the motion and detects more dots than that of at low speed. According to different speed, the horizontal and vertical counters acquire different dots in the same distance.

Features

- * Being compatible with 2D & 3D mouse mode.
- * Including buyer testing mode.
- * Built-in noise immunity circuit.
- * Low power dissipation.
- * Clocked by RC oscillating circuit or external oscillator.
- * Three key-switches and six photo-couples inputs.
- * Both key-press and key-release debounce interval 11 ms.
- * Through three key-switch inputs, TP8472 can exert seven different output.
- * Improved ESD protection.
- * Built-in auto-reference function.

Applications

- * Optical mouse or pen-mouse.
- * Mechanical mouse or pen-mouse.
- * Optomechanical mouse or pen-mouse.
- * Mechanical track ball.
- * Optomechanical track ball.



3D PS/2 MOUSE CONTROLLER

Pin Assignment

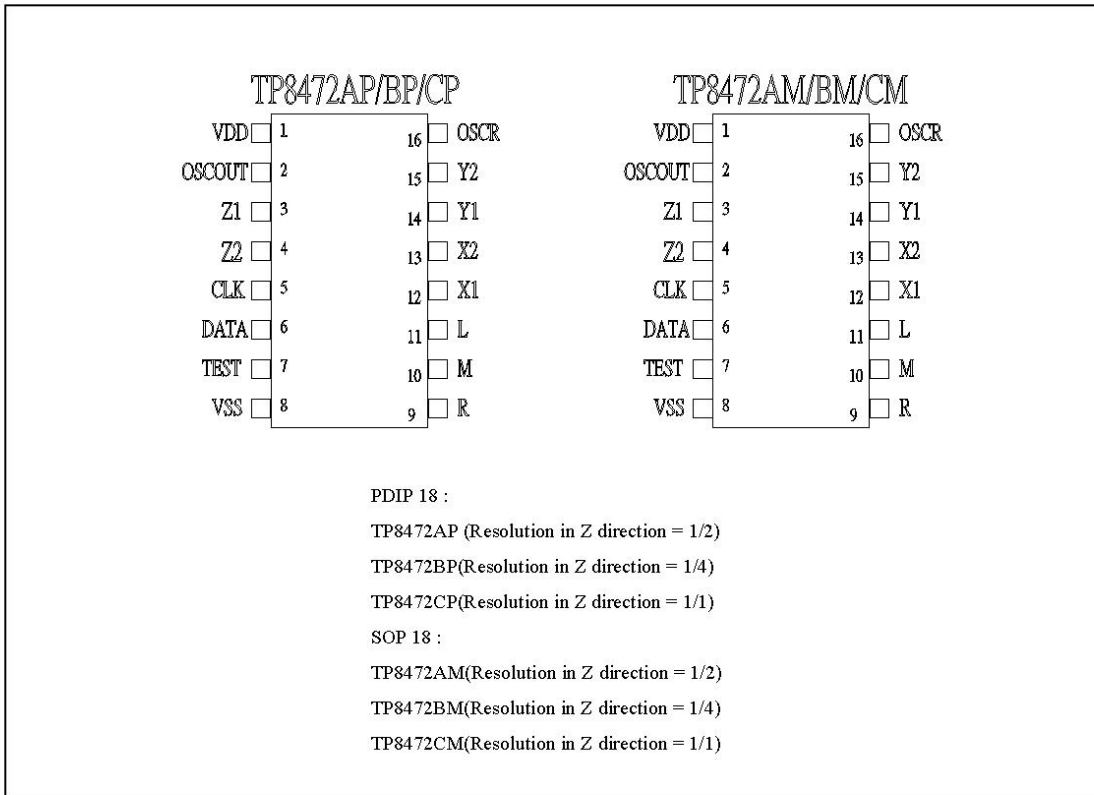

Package Type :

(1)DIP

TP8472AP , TP8472BP , TP8472CP

(2)SOP

TP8472AM , TP8472BM , TP8472CM

**3D PS/2 MOUSE CONTROLLER****Pin Description**

Pin	Name	I/O	Function
1	VDD	I	Power.
2	OSCOUT	I/O	Clock output. In test mode it is clock input.
5	CLK	I/O	8042 auxiliary port CLK line
6	DATA	I/O	8042 auxiliary port DATA line
7	Test	I	If it is connected to VDD or floated, TP8472 will work on normal operation. While it is connect to GND, TP8472 will enter testing mode, you can use OSCR to select two types of testing mode.
8	VSS		Ground.
9	R	I	Three key-switches exert seven different combinations totally.
10	M	I/O	Both key-pressed and key-released signals accompanied with horizontal and vertical state will be sent to the host. The status of the key-switches will be preserved when RXD is transmitting. The debounce interval for both key-press and key-release is 12 ms.
11	L	I/O	In testing mode, L and M are the outputs of motion detector. Use R key can select the two outputs from X1, X2 or Y1, Y2. This feature can help manufacture to adjust the phase of four photo-couples for improving the yield.
3	Z1	I	Six photo-couple signals denote UP, DOWN, LEFT, RIGHT, Scrolling UP and Scrolling down state. During the scanning period, as long as the photo-couples change their states, the value of vertical or horizontal counter will accordingly increase or decrease.
4	Z2		
12	X1		
13	X2		
14	Y1		
15	Y2		
16	OSCR	I	If it is connected a 30kohm resistor to ground, TP8472 will employ a built in RC ckt to generate clock. While it is connected to VDD, and Test connect to GND, it will enter testing mode, you can observe X/Y input on L/M pin.

Function Descriptions**(1) PS/2 Mouse Mode****(A) Operating mode**

There are four operating modes in PS/2 mouse :

a. Reset Mode :

In this mode a self-test is initiated during power-on or by a Reset command. After reset signal, PS/2 mouse will send:

(a) Completion code AA & ID code 00.

(b) Set default:

sampling rate: 100 reports/s

non-autospeed

stream mode

4 counts/mm



3D PS/2 MOUSE CONTROLLER

disable

b. Stream Mode:

- The maximum rate of transfer is the programmed sampling rate.
- Data report is transmitted if
 - (a) switch is pressed
 - (b) movement has been detected

c. Remote Mode:

Data is transmitted only in response to a Read Data command.

d. Wrap Mode:

Any byte of data sent by the system, except hex EC (Reset wrap mode) or hex FF (Reset), is returned by TP8472.

(B) PS/2 Mouse Data Report:

- a. In stream mode: A data report is sent at the end of a sample interval.
- b. In remote mode: A data report is sent in response to Read Data command.
- c. Data report format:

Byte	Bit	Description
1	0	Left button status; 1 = pressed
	1	Right button status; 1 = pressed
	2	Middle button status; 1 = pressed
	3	Reserved
	4	X data sign; 1 = negative
	5	Y data sign; 1 = negative
	6	X data overflow; 1 = overflow
2	7	Y data overflow; 1 = overflow
	0-7	X data (D0 - D7)
3	0-7	Y data (D0 - D7)
4	0-7	Z data (D0 – D6,sign bit)

(C) PS/2 mouse Data Transmission:

- a. TP8472 generates the clocking signal when sending data to and receiving data from the system.
- b. The system requests TP8472 to receive system data output by forcing the DATA line to an inactive level then allowing CLK line to go to an active level.
- c. Data transmission frame:

Bit	Function
1	Start bit (always 0)
2-9	Data bits (D0 - D7)
10	Parity bit (odd parity)
11	Stop bit (always 1)



3D PS/2 MOUSE CONTROLLER

d. Data Output (data from TP8472 to system):

If CLK keep low (inhibit status), data will not transmit.

If CLK raised to high and DATA is low(request-to-send),data is updated.

After receiving data from system, TP8452 will not start transmitting until CLK and DATA are both high.

If CLK and DATA are both high, the transmission is ready.

DATA is valid prior to the falling edge of CLK and beyond the rising edge of CLK. During transmission, TP8472 check for line contention by checking for an inactive level on CLK lasting for no more than 100m sec.

Contention occurs when the system lowers CLK to inhibit TP8472 output after TP8472 has started a transmission. If this occurs before the rising edge of the tenth clock, TP8472 internal store its data in its buffer and returns DATA and CLK to an active level. If the contention does not occur by the tenth clock, the transmission is completed.

Following a transmission, the system inhibits TP8472 by holding CLK low until it can service the input or until the system receives a request to send a response from TP8472.

e. Data Input (from system to TP8472):

System first check if TP8452 is transmitting data. If TP8472 is transmitting, the system can override the output by forcing CLK to an inactive level prior to the tenth clock. If the transmission of TP8472 beyond the tenth clock ,the system must receive the data.

If TP8472 is not transmitting or if the system choose to override the output, the system force CLK to an inactive level for a period of not less than 100u sec while preparing for output. When the system is ready to output start bit (0), it allows CLK to go to active level. If request-to-send is detected, TP8472 clocks in 11 bits. Following the tenth clock,TP8472 checks for an active level on the DATA line, and if found, force DATA low , and clock once more.

If framing error occurs, TP8472 continue to clock until DATA is high, then clocks the line control bit and request a Resend.

When the system sends out a command or a data that requires a response, the system must wait for TP8472 to response before sending its next output.

(D) PS/2 Mouse Error Handling:

- a. A Resend command (FE) following receipt of an invalid input or any input with incorrect polarity.
- b. If two invalid input are received in succession, an error code of hex FC will be sent to the system.
- c. The counter accumulators are cleared after receiving any command except "Resend".
- d. As TP8472 receives a Resend command (FE), it transmits its last packet of data.
- e. In the stream mode "Resend" is received by TP8472 following a 4-byte data packet transmission to the system. TP8472 resend the 4-byte data packet prior to clearing the counter.
- f. A response is sent within 25 ms if
 - (a) The system requires a response
 - (b) An error is detected during transmission
- g. When a command requiring a response is issued by the system ,another command should not be issued until either the response is received or 25ms has passed.



3D PS/2 MOUSE CONTROLLER

(E) PS/2 Mouse Commands Description:

There are 16 valid commands that transmits between the system and TP8472. The “EA” code is always the first response to any valid input received from the system other than a Set Wrap Mode or Resend command.

The following table list the commands:

Hex Code	Command	TP8472 echo code
FF	Reset	FA,AA,00
FE	Resend	XX,(XX,XX)
F6 Set	Default	FA
F5	Disable	FA
F4	Enable	FA
F3,XX	Set Sampling	Rate FA,FA
F2	Read Device Type	FA,00(2D mode)/03(3D mode)
F0	Set Remote Mode	FA
EE	Set Wrap Mode	FA
EC	Reset Wrap Mode	FA
EB	Read Data	FA,XX,XX,XX
EA	Set Stream Mode	FA
E9	Status Request	FA,XX,XX,XX
E8,XX	Set Resolution	FA,FA
E7	Set Autospeed	FA
E6	Reset Autospeed	FA

The continuance command sequence below will activate 3D mode.

- F3,XX
- F3,XX
- F3,XX

A power on reset or reset command will reset the controller into 2D mode .

The following describes valid commands:

a. Reset (FF)

TP8472 operation:

- (a) Complete the reset.
- (b) Transmit FA,AA,00 to the system.
- (c) Set default:
 - sampling rate: 100 reports/s
 - non-autospeed
 - stream mode
 - 4 counts/mm
 - disable

b. Resend (FE)

- (a) Any time TP8472 receives an invalid command, it returns a Resend command to the system.
- (b) When TP8472 receives a Resend command, it retransmits its last output. If the



3D PS/2 MOUSE CONTROLLER

last packet was a Resend command, it transmits the packet just prior to the Resend command.

- (c) In stream mode, if a Resend command is received by TP8472 immediately following a 4-byte data packet transmission to the system, TP8472 will resend the 4-byte data packet prior to cleaning the count accumulators.

c. Set Default (F6)

The command reinitializes all conditions to the power-on defaults.

d. Disable (F5)

This command is used in the stream mode to disable transmissions from TP8452.

e. Enable (F4)

Enable transmissions, if in stream mode.

f. Set Sampling Rate (F3,XX)

In the stream mode, this command sets the sampling rate to the value indicated by byte hex XX, shown as follows:

Second byte XX	Sample Rate
0A	10/sec
14	20/sec
28	40/sec
3C	60/sec
50	80/sec
64	100/sec
C8	200/sec

g. Read Device Type (F2)

TP8472 always echoes “ FA,00 “ in 2D mode, “FA 03” in 3D mode.

h. Set Remote Mode (F0)

Data value are reported only in response to a Read Data command.

i. Set Wrap Mode (EE)

Wrap mode remains until Reset (FF) or Reset Wrap Mode(EC) is received.

j. Reset Wrap Mode (EC)

TP8472 returns to the previous mode of operation after receiving this command.

k. Read Data (EB)

This command is executed in either remote or stream mode. The data is transmitted even if there has been no movement or the button status is unchanged since the last report. Following a Read Data command, the registers are cleared after a data transmission.

l. Set Stream Mode (EA)

This command sets TP8472 in stream mode.



3D PS/2 MOUSE CONTROLLER

m. Status Request (E9)

When this command is issued by the system, TP8472 responds with a 3-byte status report as follows:

Byte	Bit	Description
1	0	1 = Right button pressed
	1	1 = Middle button pressed
	2	1 = Left button pressed
	3	Reserved
	4	0 = Normal speed, 1 = Autospeed
	5	0 = Disabled, 1 = Enabled
	6	0 = Stream mode, 1 = Remote mode
	7	Reserved
2	0-7	Current resolution setting (D0 - D7)
3	0-7	Current sampling rate (D0 - D7)

n. Set Resolution (E8,XX)

TP8472 provides four resolutions selected by the second byte of this command as follows:

Second Byte XX	Resolution
00	1 counts/mm
01	2 counts/mm
02	4 counts/mm
03	8 counts/mm

o. Set Autospeed (E7)

At the end of a sample interval in the stream mode, the current X and Y data values are converted new values. The sign bits are not involved in this conversion. The conversion is only in stream mode. The relationship between the input and output count is as follows:

Input	Output
0	0
1	1
2	1
3	3
4	6
5	9
N(>=6)	2.0*N

p. Reset Autospeed (E6)

This command restore normal speed.



TP8472

3D PS/2 MOUSE CONTROLLER

(2) Testing Mode

Whenever "Test" pin is connected to GND, the chip will enter buyer's testing mode.

If OSCR (connect to VDD) = "1" : The X direction output signals of comparators will present to "L" and "M" pin. Pressing "R" key can toggle the output from X direction to Y direction.

If OSCR (connect to GND) = "0" : The TP8472'S Internal RC won't generate clock. you can input clock on OSC.OUT pin to let TP8472 work on normal operation.



3D PS/2 MOUSE CONTROLLER

Absolute Maximum Ratings

Parameter	Min.	Ratings	Max.	Unit
Supply voltage	-0.3		6.5	V
Temperature under bias	0		70	°C
Storage temperature range	-65		150	°C
Power dissipation	-		500	mW

DC Electrical Characteristics (Ta=25 to 70 °C)

Parameter	Sym.	Min.	Typ.	Max.	Unit
Operating voltage	V _{DD}	4.5	5.0	5.5	V
Operating current (with load)@32kHz	I _{op}			5.5	mA
OSCR high input voltage	V _{rh}	4			V
X1,X2,Y1,Y2,Z1,Z2 input reference Current	I _{pi}	75(1v)		334(5v)	uA
CLK,DATA positive-going threshold voltage	V _{t+}	3.2		3.8	V
CLK,DATA negative-going threshold voltage	V _{t-}	1.2		1.9	V
Low input voltage, other pins	V _{ai}			1.5	V
High input voltage , other pins	V _{aih}	3.5			V
L,M,R input current (pull low resistor, V _{in} =5V)	I _{mi}	35		45	uA
DATA, CLK input current (pull up resistor, V _{in} =0V)	I _{dc}	-0.6		-1.86	mA
DATA, CLK low output voltage (I _{prl} =4mA)	V _{prl}			0.4	V
OSC IN input leakage current (V _{in} =5V)	I _{ih 0}			1.0	uA
L,M,R input leakage current (V _{in} =0V)	I _{il}	-1		1	uA
X1, X2,Y1,Y2,Z1,Z2 input leakage current (V _{in} =0V)	I _{ipl}	-1		1	uA
Input resistor of button(R/L/M, V _{op} =5V)	R _{in(R/L/M)}		30		Ohm
Input resistor of X/Y/Z(V _x =V _y =V _z =5V)	R _{in(photo)}		14		Ohm

* All voltages in above table are compared with V_{SS}.

* All parameters in above table are tested under V_{DD}=5V.

* CLK & DATA output gates are open drains that connect to pull up resistors.



3D PS/2 MOUSE CONTROLLER

AC Electrical Characteristics (Ta=25 to 70 °C)

Parameter	Sym.	Min.	Typ.	Max.	Unit
Oscillating frequency KHz	Fosc	32.5-10%	32.5	32.5+10%	
Key debounce	Tkd		12		ms
Rising edge crossed width (Fosc=32KHz)	Tr	14.9			us
Falling edge crossed width (Fosc=32KHz)	Tf	14.9			us
Mouse CLK active time	Tmca		44.8		us
Mouse CLK inactive time	Tmci		44.8		us
Time that mouse sample DATA from CLK rising edge	Tmdc		14.9		us
System CLK active time	Tsca		44.8		us
System CLK inactive time	Tsci		44.8		us
Time from DATA transition to falling edge of CLK	Tsdc		14.9		us
Time from rising edge of CLK to DATA transition	Tscd		28.6		us
Time to mouse inhibit after the 11th CLK to ensure mouse does not start another transmission	Tpi	0		50	us

PS. The AC timings are measured with 32.5 KHz system clock signal.



3D PS/2 MOUSE CONTROLLER

R-C Frequency Characteristics (R=950KΩ to 1202KΩ)

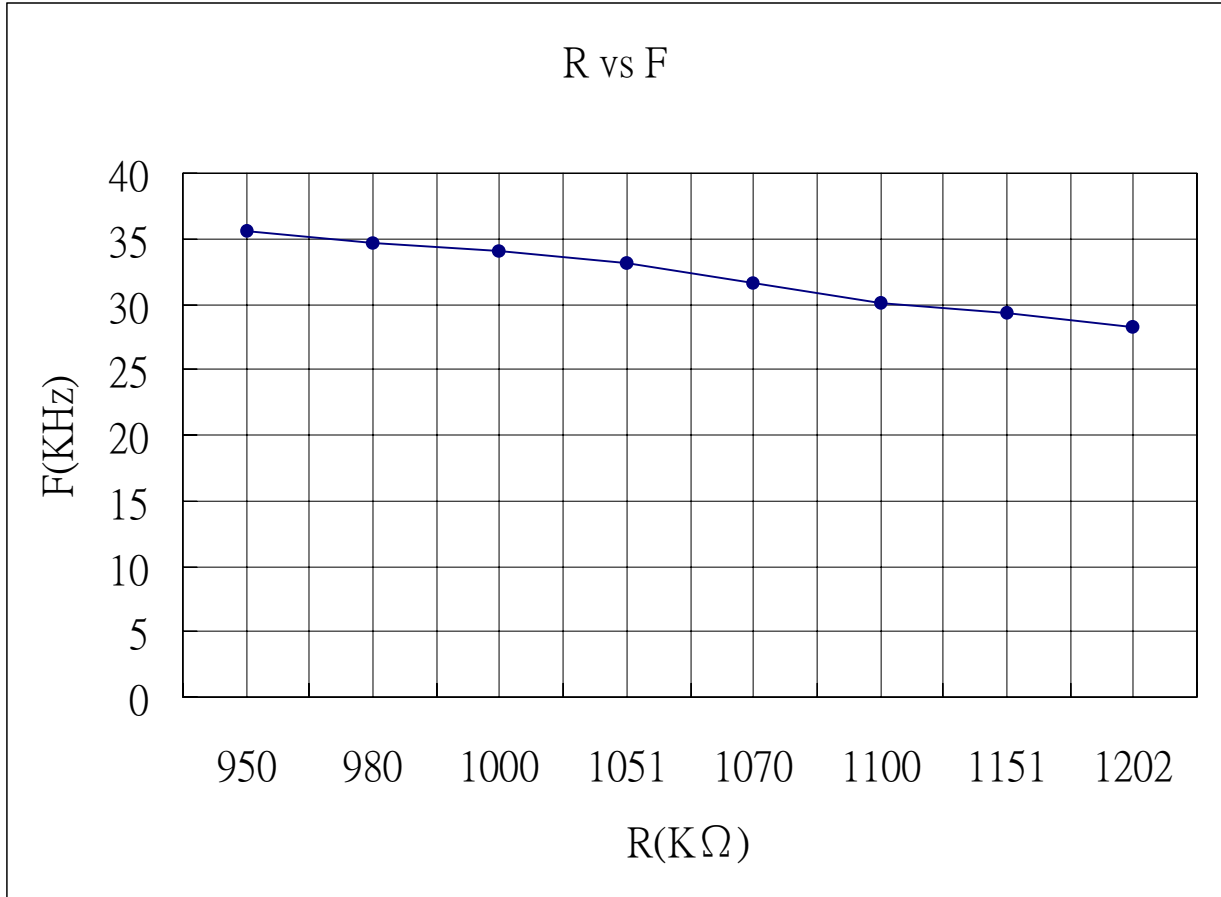



3D PS/2 MOUSE CONTROLLER

Timing Diagram

(A) Photo-couples pulse width

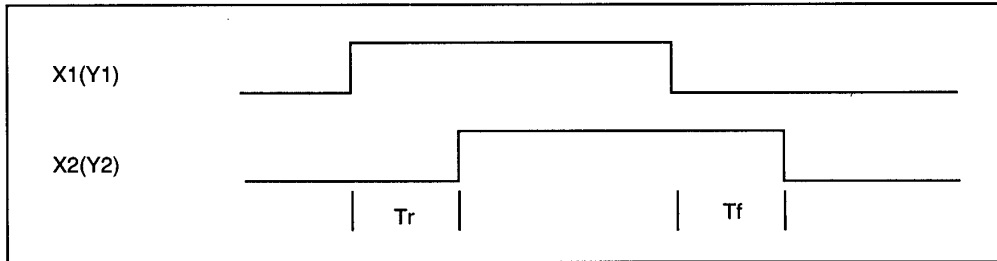

(B) Receiving Data

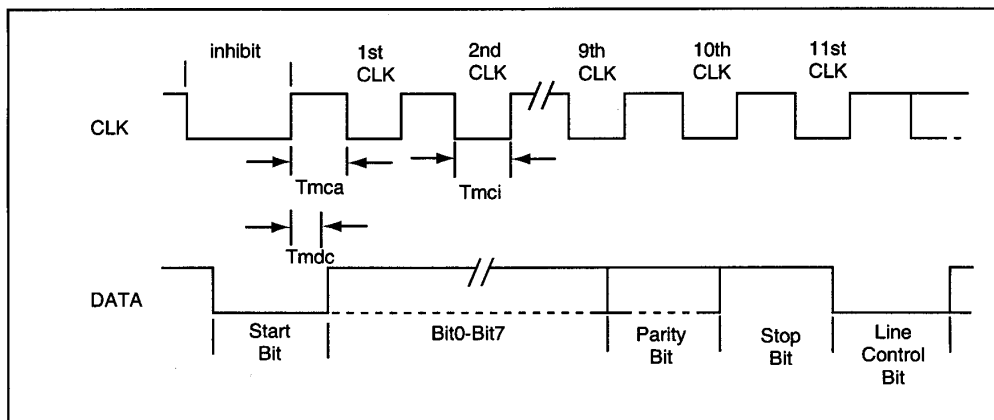

(C) Sending Data

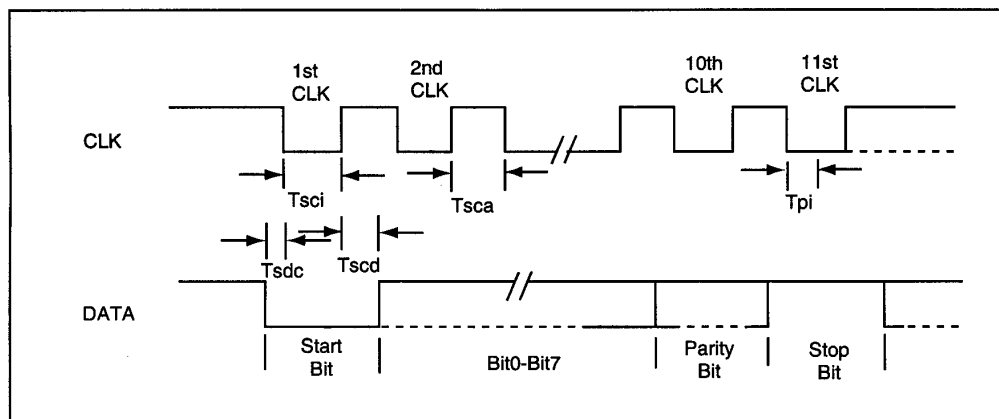



3D PS/2 MOUSE CONTROLLER

AC Timing point

Output:

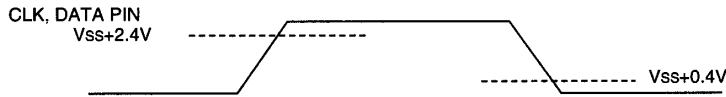

Input:

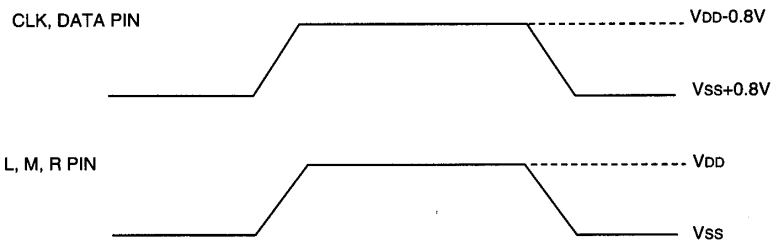

I/O equivalent circuit :

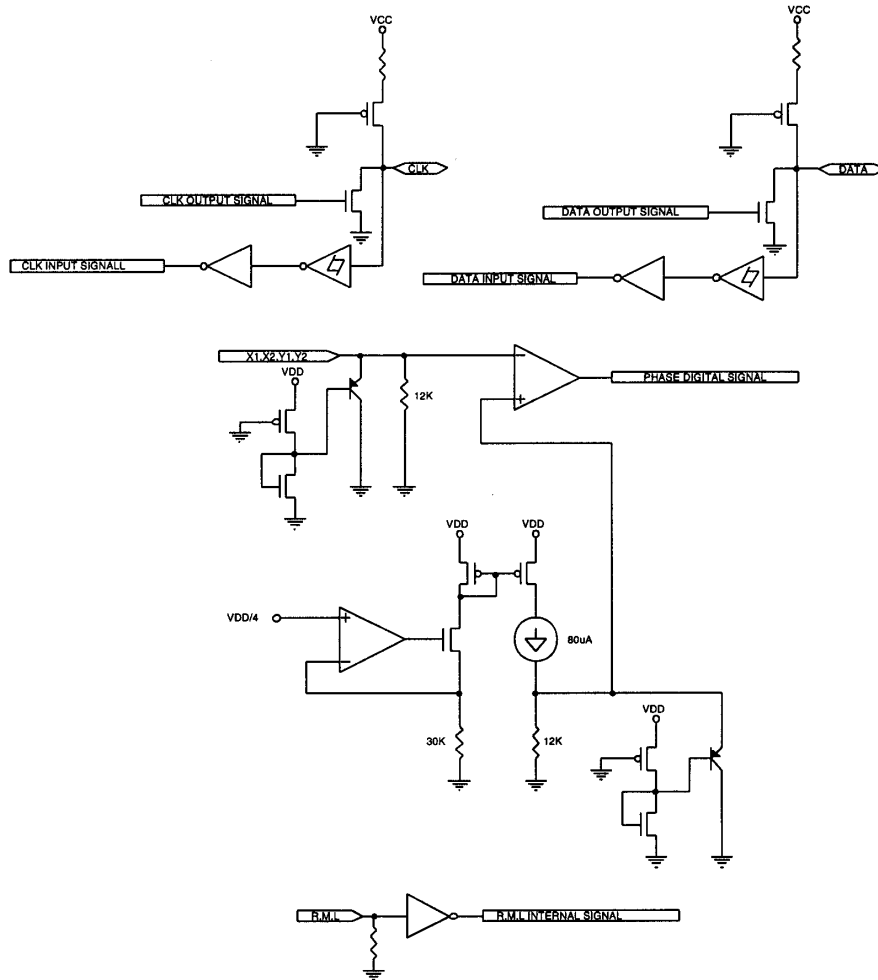



TP8472

3D PS/2 MOUSE CONTROLLER

Application Example

(1) Switch Encoder for 3D

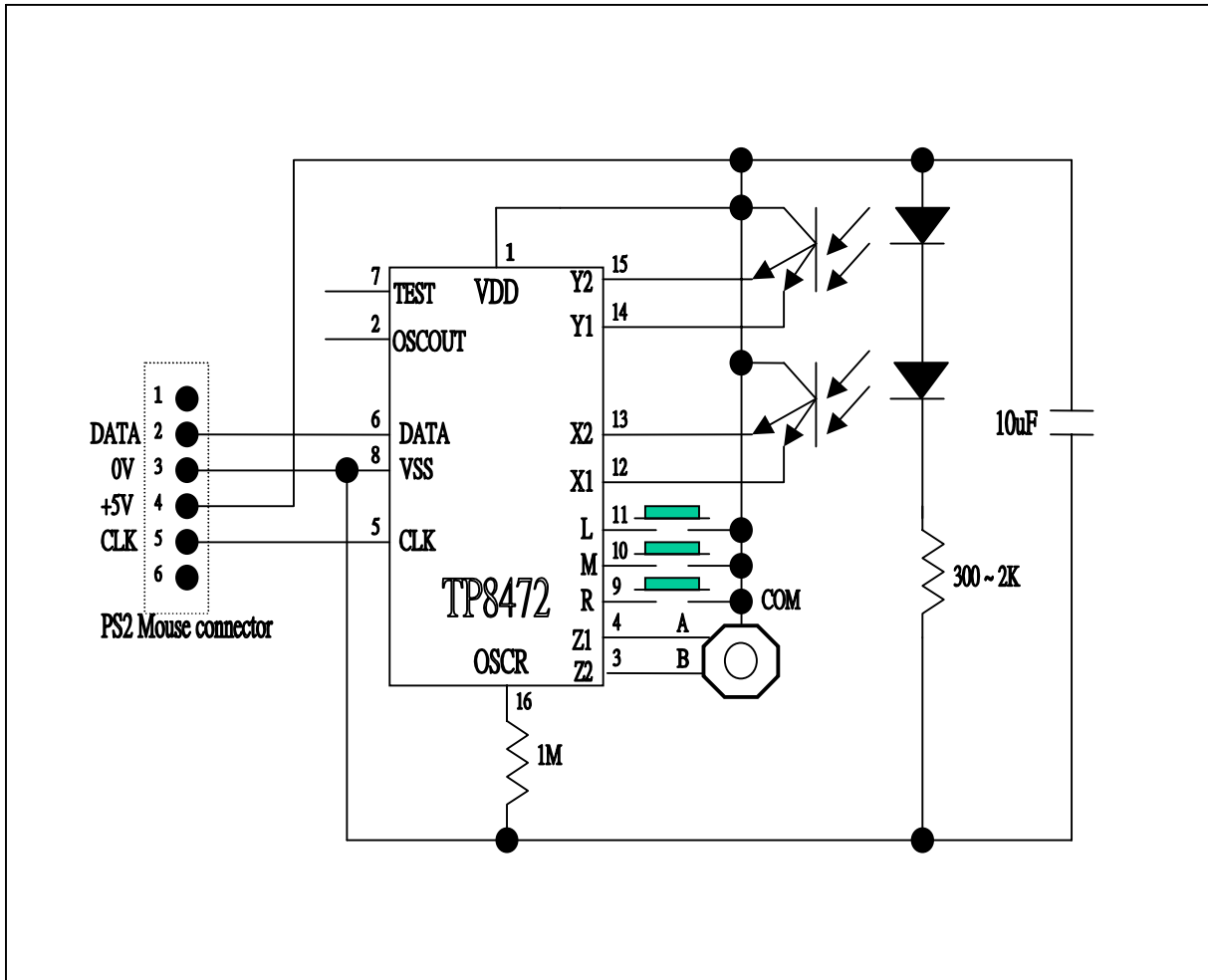



3D PS/2 MOUSE CONTROLLER

(2) Semi-photo Sensor for 3D:

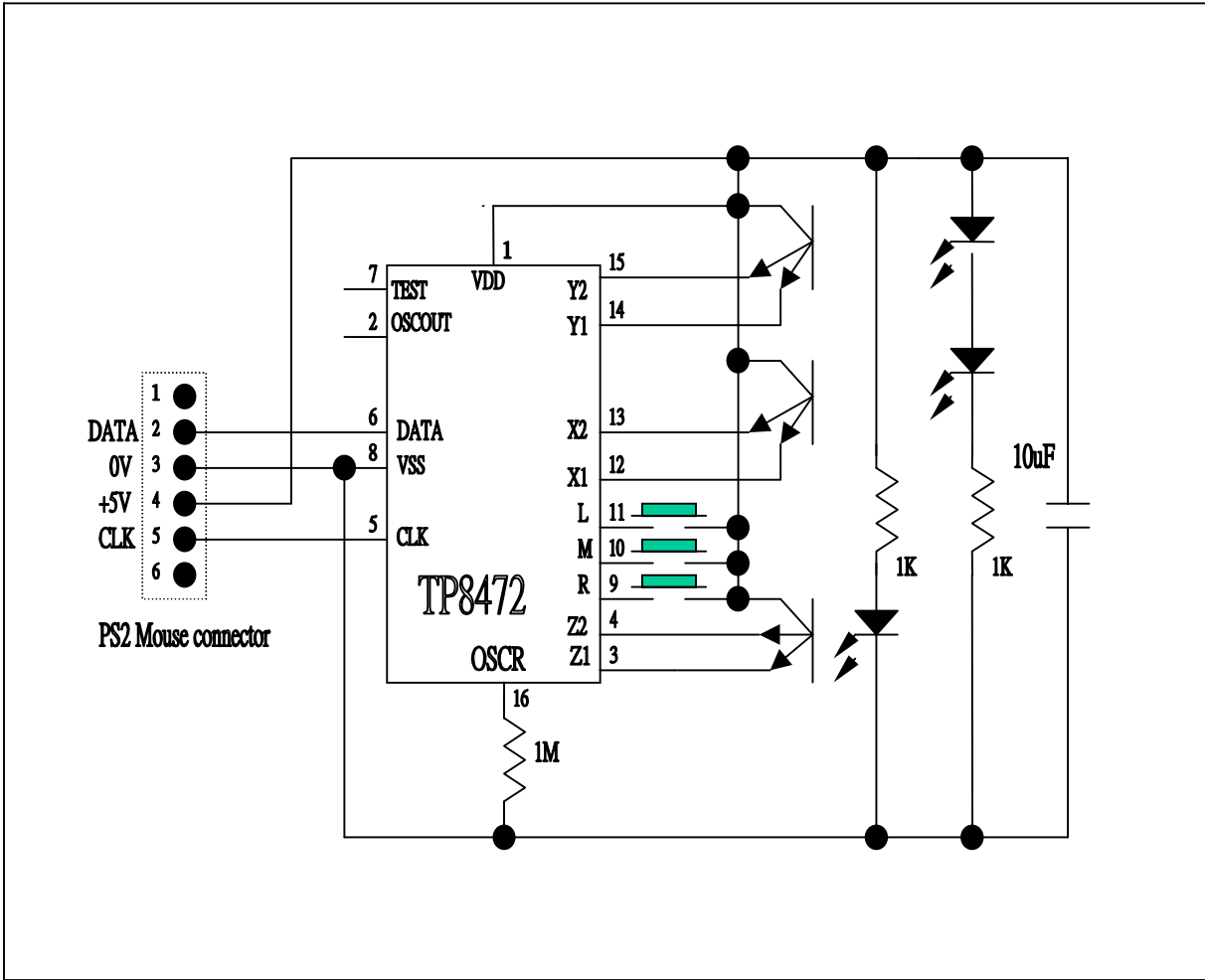



TP8472

3D PS/2 MOUSE CONTROLLER

(3) Optical Sensor for 3D :

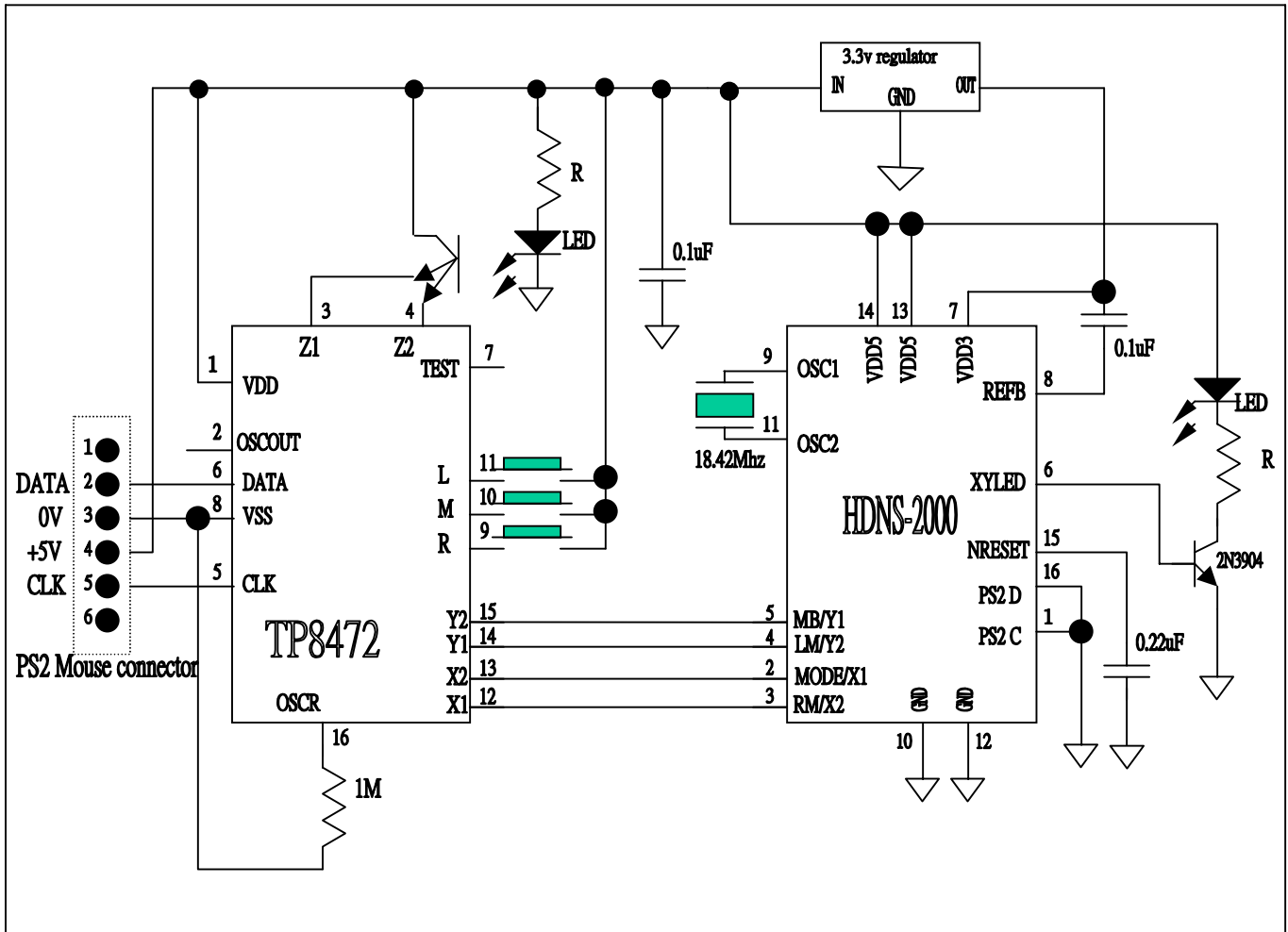



TP8472

3D PS/2 MOUSE CONTROLLER

Package Types :

- (1) PDIP 16 pin
- (2) SOP 16 pin

