

IMPEDANCE MATCHING: A PRIMER

From time to time you'll come across the term 'impedance matching' in various areas of electronics, and especially in fields like RF and audio engineering. However even in these fields it's often misused, probably because many people don't really understand the concepts behind it.

In this primer we'll try to clarify what impedance matching is really all about, why it's important in some situations — and *not* important in others.

Textbooks usually explain the idea of impedance matching with a very simple example of an electrical generator feeding a resistive load, as shown in Fig.1. Because the generator has an internal resistance of its own (R_G) — as all real generators do — this tends to dissipate some of the generator's output power as heat, whenever we connect a load to its output terminals. So the full mechanical power fed into the generator can't be drawn from it as electrical power, because some will always be wasted in R_G .

When early electrical engineers were faced with this problem, they naturally enough did everything they could to reduce the internal resistance of their generators. However they were inevitably still left with **SOME** internal resistance, because it's impossible to reduce the resistance to zero unless you run the generator at a temperature of close to absolute zero (0Kelvins, or -273°C).

Once they had minimised the internal resistance, their next step was to see if there was some way that they could minimise the amount of power wasted in it, by varying the resistance of the load. And what they discovered is shown in the Fig.2, which plots the amount of power transferred into the load R_L as its resistance is varied. As you can see, the amount of power reaches a peak or **MAXIMUM** when the load resistance is the same as — or 'matches' the generator resistance. It falls away for values both higher and lower than this figure, showing that matching the two is clearly desirable if we want to maximise the power able to reach the load.

So this is where the idea of matching the resistance of the load to that of the generator came from. Before long, it was extended to cover the general situation of any load impedance connected to a source of electrical energy or voltage (EMF), with its own internal source

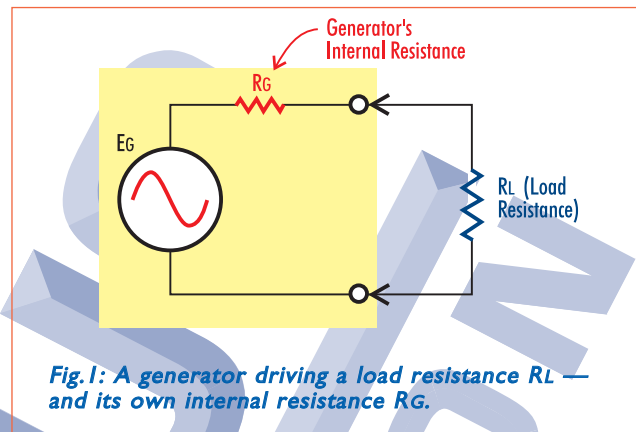

Fig.1: A generator driving a load resistance R_L — and its own internal resistance R_G .

impedance. And the idea of matching the load and generator resistance became one of matching the source and load impedance — *impedance matching*.

Now this may sound simple and straightforward, but it's important to remember where the idea came from, and also realise what exactly is going on when we do match load and generator/source resistances or impedances. True, the **POWER** transferred to the load will be a maximum; but at the same time, the *actual* power being dissipated in the generator's internal resistance is **EXACTLY THE SAME** as that reaching the load! In other words, **HALF** the total power from the generator is now being turned into heat inside R_G , because its resistance is now half the total connected across the generator. The 'other half' is the load resistance R_L .

For exactly the same reason, R_G and R_L will now be acting as a 2:1 voltage divider across the generator — so that only **HALF** the generator's output voltage (E_G) will be appearing across the load. In terms of voltage transfer, then, matching the impedances isn't particularly efficient: it actually gives a 6dB loss.

Does this mean that impedance matching really only applies to generators in power stations? No, and in fact it doesn't really apply there either — or at least, not simply. All it really means is that as you draw more and more power from a generator by reducing the load resistance, a point is reached where half the generator's output power is being wasted inside it. Obviously with very high power generators it's not a good idea to load them even this heavily — let alone dropping the R_L even further, where even more power is lost inside the generator than reaches the load. (See the blue curve in Fig.2, showing the power lost in the generator.) Most power station generators are loaded with an R_L somewhat higher than R_G , to waste as little power as possible.

So when **IS** impedance matching a good idea? Glad you asked. Basically it's for situations rather different from that in Fig.1, where we're stuck with a particular load or cable impedance, and we still want to either maximise the power transferred into the load, or minimise the amount of power reflected back from it into the cable, or both.

RF CABLE MATCHING

For example in many RF situations, we tend to have a relatively fixed **LOAD** impedance — say a resonant

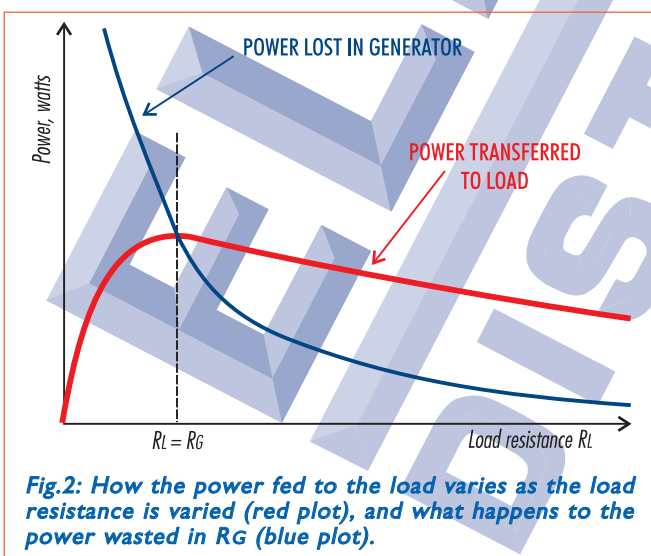

Fig.2: How the power fed to the load varies as the load resistance is varied (red plot), and what happens to the power wasted in R_G (blue plot).

Electus Distribution Reference Data Sheet: IMPMATCH.PDF (2)

quarter-wave antenna, with an impedance of 50 ohms resistive. To minimise interference we also have to use coaxial cable to connect the antenna to a transmitter or receiver.

Now as you may be aware, coaxial cable behaves as a *transmission line* at radio frequencies, and as a result it has its own *characteristic impedance*. This simply means that because of the inductance-to-capacitance (or L/C) ratio of the cable, RF energy tends to move along it with a particular ratio between the electric and magnetic fields (i.e., voltage to current).

In most cases when the energy reaches the end of the cable, we want as much as possible to transfer into our load — the antenna, in the case of a transmitter, or the input RF stage in the case of a receiver. For a transmitter this gives the highest power efficiency, while for a receiver it gives the best noise performance.

And guess what? To ensure this optimum energy transfer, we need to match the characteristic impedance of the cable to the impedance/resistance of the load. So for a 75Ω antenna or receiver input, we need to use 75Ω coaxial cable. For a 50Ω antenna we need to use 50Ω cable, and so on. (see Fig.3)

This, then, is an area where impedance matching IS quite important. Because what happens if the cable and antenna (or receiver) impedances are NOT matched is that some of the RF energy reaching the end of the cable won't be transferred into the load, but is REFLECTED back along the cable, towards the source. This can set up standing waves in the cable (another cause of power loss, and possibly cable damage), and can

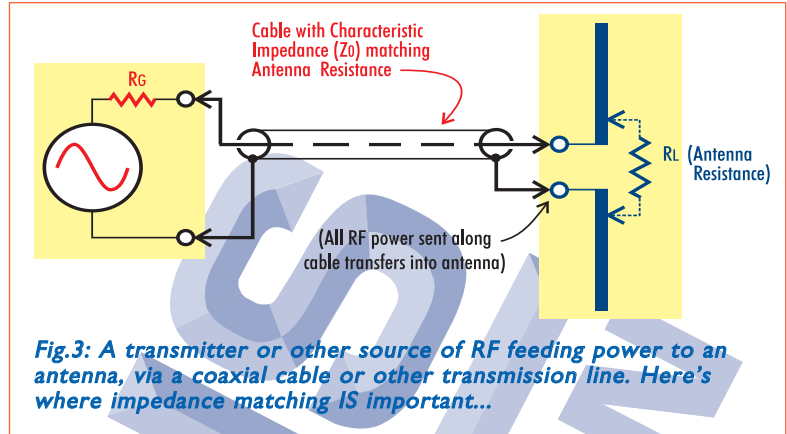

thing is to ensure that the transmitter output stage will feed as much RF energy as possible into the cable's input impedance. There can even be an advantage in deliberately mismatching the impedances (i.e., having the transmitter impedance much lower than the cable), to minimise power loss in the final stage and also ensure that if RF is reflected back from the antenna end, most of it is bounced right back up again. So this situation is a bit like the generator in a power station...

VIDEO INTERCONNECTIONS

Now let's consider another area where impedance matching again tends to be quite important: video interconnections. Here we're dealing with signals which span from DC up to about 6MHz or so — well into the 'RF' range. And we also tend to find ourselves using coaxial cables, to reduce interference. So again we need to match the cable impedance and the load impedance, to prevent signal reflection. With video, these reflections can cause *ringing* and *ghosting* in the final picture. (Ringing is multiple edges on outlines in the picture, while ghosting is multiple images — each shifted horizontally.)

Most video equipment is designed to be interconnected with 75Ω cables, and has inputs which are designed to present this same input impedance. So matching tends to occur automatically, providing you use the correct cables.

How about video outputs — are these impedance matched too? Yes, generally they are, not because it results in maximum signal transfer but because with video signals we DON'T want any signal reflected back from the load to be reflected back all over again — this would make ringing even worse. So often the video outputs of cameras, VCRs, DVD players and so on are fitted with a 75Ω series resistor inside, to provide 'back termination' for the cable (Fig.4). This is just another name for impedance matching at the source end of the output cable.

Note that just as with our original generator in Fig.1, this added impedance matching resistor produces an inevitable 6dB loss of signal — half the video output is lost in the resistor. That's the penalty of impedance matching at the source end, and it's why the output buffer amplifier in video equipment is usually given a gain of twice what is needed, to allow for the unavoidable 6dB loss when a cable and correctly terminated load are connected.

also cause overheating in the transmitter output stage. In a receiver, the mismatch degrades the effective receiver gain and noise figure.

How do you ensure correct impedance matching in this type of RF situation? Generally the cable impedance is more or less fixed, and the antenna impedance may be the same. But quite a few techniques have been evolved to 'tweak' the matching between the two: tuned stubs, quarter-wave transformers and so on. Similar things can be done at the input of a receiver. For details of these RF matching techniques you'll have to refer to a good RF textbook, like *The ARRL Handbook*.

Notice though that so far we've only considered the situation at the LOAD end of the RF cable. How about the source end — isn't impedance matching important there too? Less so, especially for transmitters. The main

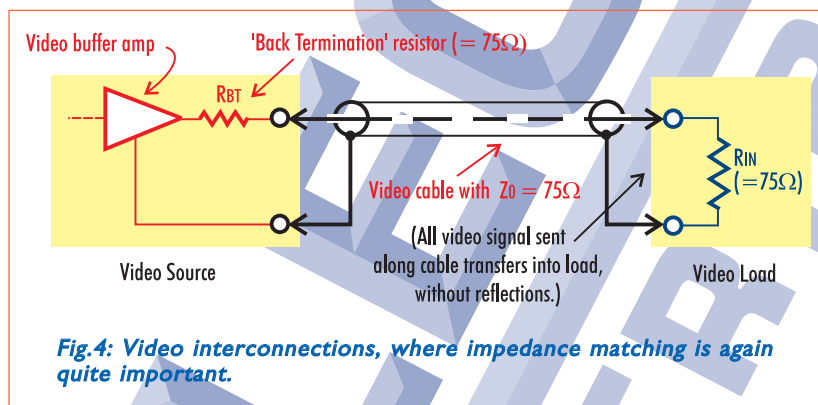

AUDIO IMPEDANCE MATCHING

How about impedance matching in audio applications? There are a few applications where it's important, but perhaps not as many as you might think.

Because audio signals are quite low in frequency, it's generally only where they have to be sent over quite long cables that transmission-line effects make it necessary to perform impedance matching to prevent reflections. And in most cases, we can get quite efficient signal transfer simply by arranging for the output impedance of our audio source (such as an amplifier) to be much lower than that of our load (such as a loudspeaker).

In the case of most hifi amplifiers and speakers, for example, we generally arrange for the amplifier output impedance to be very much LOWER than the speaker impedance. A typical speaker impedance is 8Ω , for example, but most hifi amplifiers have an output impedance of 0.1Ω or less (Fig.5). This not only ensures that most of the audio energy is transferred to the speaker, but also that the amplifier's low output impedance provides good electrical DAMPING for the speaker's moving voice coil — giving higher fidelity.

Older valve amplifiers needed a different form of impedance matching, because output valves generally had a fairly fixed and relatively high output impedance, so they couldn't deliver audio energy efficiently into the low load impedance of a typical speaker. So an output transformer had to be used, to produce a closer impedance match. The transformer 'stepped up' the impedance of the speaker, so that it gave the output valve an effective load of a few thousand ohms; this was at least comparable with the valve's own output impedance, so only a small amount of energy was wasted as heat in the valve.

The only other area in audio where impedance matching (of a different kind) tends to be important is with transducers like microphones, gramophone pickups, tape heads and so on. Here the transducer often needs

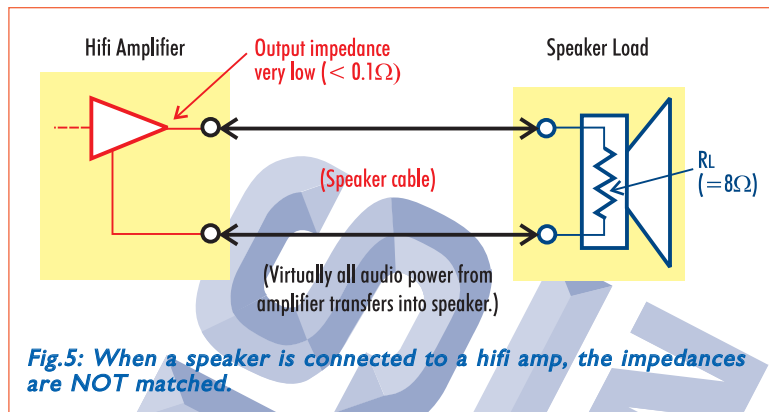

Fig.5: When a speaker is connected to a hifi amp, the impedances are NOT matched.

to be provided with a particular load impedance, but not in order to maximise power or signal transfer. Generally it's to ensure that the transducer performance is better controlled by the electrical damping effect of the load.

For example when correctly loaded these transducers might have 'cleaner' output, with fewer unwanted resonances and hence a much flatter response.

SUMMARY

Hopefully this has given you a better understanding of the idea of impedance matching, where it came from and what it's really designed to achieve.

As you can see, true impedance matching is generally only needed for RF and video interconnections — and mainly at the LOAD end of coaxial cables or other transmission lines.

Remember too that when impedance matching is performed at the SOURCE end of a cable, there's always a penalty: loss of power (-3dB) or signal level (-6dB), because when the generator impedance and the impedance of its load are equal, half the power is inevitably lost in the generator resistance.

(Copyright © 2001, Electus Distribution)