

Declaration

The firmware of DBM01 was updated on Dec 23, 2013. Comparing to the old version, some new functions are added:

- AT commands are added.
- Central/peripheral mode can be switched in the same board
- Power-saving modes are introduced

DBM01
2.4-GHz Low Energy Bluetooth 4.0 Module

V2.11

Features:

- Frequency Range: 2402~2480MHz
- UART Data Interface
- Sensitivity: -93dBm
- Output Power: ≥ 3 dBm
- AES-128 Encryption and Decryption
- Self-adaptable frequency hopping
- Different power-saving modes
- Four types of pairing mechanism
- Supply voltage: 2.0~3.6V

**Applications**

- 2.4GHz Bluetooth low energy system
- Mobile phone accessories
- Sports and leisure equipment
- Consumer Electronics
- Human interface devices
- USB dongles
- Health care and medical

**DESCRIPTION**

DBM01 is a type of low energy data transmission Bluetooth module based on CC2540 from Texas Instruments. Combining the advantages of compact size, extra low power consumption, strong anti-interference and long communication distance, it is very suitable for short range wireless communication in Things of Internet. The module integrates PCB antenna on board. Because the RF circuits of DBM01 are well matched and optimized, users are free from time-consuming RF design and only need to focus on the slight work on UART communication.

DBM01 can be used to communicate with other Bluetooth devices such as iPhone system. This module can be switched between Central mode and peripheral mode by external I/O pin or AT commands. In peripheral mode, users can set modules in different power-saving modes by changing the broadcasting time through AT commands. DBM01 provides four types of matching modes for Central and Peripheral modules, which provides high flexibility for different applications.

PIN FUNCTIONS

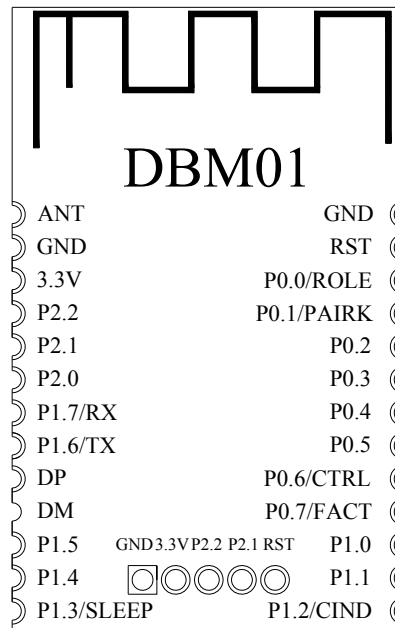

Figure 1: DBM01 Pin Layout

PIN	Name	Function	Description
1	ANT	ANT port	Optional; DBM01 has antenna on board so it should be floated
2	GND	Ground	Ground (0V)
3	VCC	Power	+2.0~3.6V
4~6	P2.2~P2.0	Digital I/O	Digital Input/Output pin
7	RX/P1.7	UART port	UART interface; RX pin
8	TX/P1.6	UART port	UART interface; TX pin
9	DP	USB port	USB positive +, no function
10	DM	USB port	USB positive -, no function
11~12	P1.5~P1.4	Digital I/O	Digital Input/Output pin
13	SLEEP/P1.3	Digital I	Low→ effective, the module will be forced to enter into sleep mode even there is data flow at UART interface. The module will quit sleep mode when there is a low-to-high pulse on it
14	CIND/P1.2	Digital O	Connection indication, Low→ unconnected, High→connected
15~16	P1.1~P1.0	Digital I/O	Digital Input/Output pin
17	FACT/P0.7	Digital I	Low→effective at start-up, default UART data format will be loaded but flash is not overlapped.
18	CTRL/P0.6	Digital I	This pin is used to configure the UART interface to command mode or transparent data mode. Low→ command mode, High→ transparent data mode. When the level of this pin is changed, users need to wait for 200ms at least before using

			UART interface
19~22	P0.5~P0.2	Digital I/O	Digital Input/Output pin
23	PAIRK/P0.1	Digital I	Matching key port. Low-→ effective only when PAIRM is 1 and FORCEK is 0.
24	ROLE/P0.0	Digital I	Central/peripheral mode selection, only effective at start-up. Low→ Central module, High→Peripheral module
25	RST	Input	Reset pin; Low effective
26	GND	Ground	Ground (0V)

Table 1: DBM01 Pin Functions

ELECTRICAL SPECIFICATIONS

Symbol	Parameter (condition)	Min.	Typ.	Max.	Units
VCC	Supply Voltage	2.0	3.3	3.6	V
Temp	Operating temperature range	-10	25	60	°C
Freq	Frequency range	2.402		2.48	GHz
IDD_R	RX current in data transmission mode			22.1	mA
IDD_T	TX current in data transmission mode			31.6	mA
IDD_S	Current in sleep mode.		500		uA
Pout	Max. output power		3	4	dBm
Sen.	Receiver sensitivity			-93	dBm

Table 2: DBM01 Electrical Specifications

ABSOLUTE MAXIMUM RATINGS

Symbol	Parameter	Min.	Max.	Units
VCC	Supply Voltage	-0.3	3.6	V
VI	Input voltage	-0.3	VCC+0.3	V
VO	Output voltage	-0.3	VCC+0.3	V
Tsr	Storage temperature	-55	125	°C

Table 3: DBM01 Maximum Ratings

APPLICATIONS

DBM01 module can work at default data formats. Users also can change the factory settings by AT commands according to actual application situations.

Baud rate	Data bit	Stop bit	Parity check	Flow control
38.4 kbps	8 bits	1 bit	No	No

Table 4: DBM01 Default UART Data Format

DBM01 can be configured to work as peripheral module or central module. There are four types of pairing mechanism between central module and peripheral module. Only one type of mechanism can be chosen for one pair of modules at the same time. Users can choose the suitable pairing mechanism by AT command **AT+PAIRM=X**. In real application, the peripheral module is responsible for broadcasting its own information and waits for connecting. For the central module, it scans surrounding peripheral modules and launches the connection to a peripheral module actively.

1. Automatic Mode (AT+PAIRM=0)

It is the default mode when the parameters of DBM01 modules are not changed by AT commands. In this mode the peripheral module will broadcast its information and wait for the connection request from the central module. The central module scans the surrounding peripheral modules and connects to the first peripheral module which it finds.

Please note that if the PAIRK pin [P0.1] is connected to logic low, the module will quit this mode and enter into PAIRK mode. The central module will scan and connect the peripheral in PAIRK pairing mechanism. This mode is suitable for two types of situations.

- **Single peripheral module application**

In this mode, the ROLE pin is floated so the DBM01 module works as peripheral module. The IPHONE or Android device plays the role of central module. The devices will scan all surrounding peripheral modules and list them on the screen by a certain APP. The APP will choose the targeted peripheral module and start connection and communication.

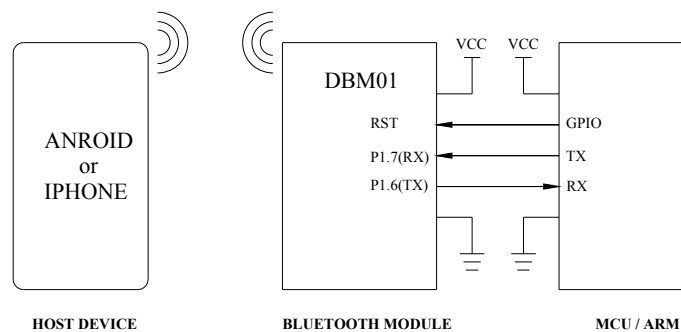

Figure 2: DBM01 Connection Diagram

- **Simple transparent data transmission**

For the application that only two DBM01 modules are used, one DBM01 module is set to central mode by connecting the ROLE to logic low and another to peripheral module as default. The central module will find the peripheral module automatically and start the connection as soon as the two modules are powered on. Please note that if there are more than one peripheral module, the central module will choose one peripheral module randomly.

2. PAIRK Mode (AT+PAIRM=1)

This mode is applicable for those applications which the GPIO pin (P1.0) can be controlled manually by external button. When the PAIRK pins of central module and peripheral module are connected to logic low simultaneously, the two modules start pairing, connecting and communicating. Because the central module takes some time to scan the peripheral modules, it needs some time to pull the PAIRK pin down and release them when the connection succeeds. Users can monitor the level of CIND pin (P1.2) to judge if the connection is successful or not.

If there are many pairs of central module and peripheral modules in the same place, only one pair of central module and peripheral module can be operated in the same time. If there are more than two modules are pulled down to the PAIRK pin, the paired modules are randomly.

Generally the GPIO pin (P1.0) is used to judge if the modules are set in PAIRK MODE. Users also can use AT commands to change the PAIRK mode forcibly. The command **AT+FORCEK=1** is equal to pull down the PAIRK pin and the command is equal to release the PAIRK pin logically. The two commands don't reflect to the physical level of GPIO pin (P1.0).

- For the application that there are many Bluetooth toys and one controller. The Bluetooth toys use peripheral modules and the controller uses the central module. When users want to control one toy, the buttons (connecting to PAIRK pin) of that toy and the controller are pressed down. They will enter into PAIRK mode and the pairing will be finished automatically. If another toy needs to be controlled, then the new toy and the controller can be operated just like the first pair.

3. PAIRC Mode (AT+PAIRM=2)

The central module and peripheral module establish connection when they are set with the same pair code which can be any of 32bit integers except 0x00000000 for which it is used to cancel the pair code. Users can use command **AT+PAIRC=X** to set pair code. The X means the integer in Hex code.

In this application many central modules and peripheral modules can coexist. For example, if central module A is set with pair code 0x12345678, it only communicates with the peripheral module with pair code 0x12345678. For the central module with pair code 0x88888888, it

only connects to the peripheral module with pair code 0x88888888. If there are more than two modules set with the same pair code, the central module pairs with one peripheral module randomly so users should avoid such configuration in the application.

- In wireless LED control based on DBM01 modules, one controller and one LED lamp are set with the same pair code. Other controllers will not connect the targeted LED lamp and avoid mal-operation.
- In the production room there are many worktables. Each worktable is equipped with a peripheral module with an unique pair code which can be labeled on the worktable. The scanner is equipped with a central module. When the scanner needs to read the data from one worktable, it can change the pair code of central module to the same as the code on the worktable and establish communication between the targeted worktable and it.

4. PAIRA Mode (AT+PAIRM=3)

This mode refers to the address matching between two Bluetooth modules. Because each module has an unique address, it can avoid random pairing. Users can use AT command **AT+ADDR** to get the Bluetooth module's address of its own. For example, users can use **AT+ADDR** command to get the address of central module X and peripheral module Y. Users then set the PAIRA of central module to Y by command **AT+ADDR=Y** and the PAIRA of peripheral module to X by command **AT+ADDR=X**. Then users save the change by command **AT+SAVE** and reset the module by command **AT+RESET** to activate PAIRA mode. In this mode, the two modules only can establish connection when they store the PAIRA of each other. If IPHONE or other mobile systems scan the peripheral module in this mode, the system can't connect the peripheral module.

- This mode is suitable for the applications which the PAIRA of targeted modules are not needed to change frequently. In parking system, the scanning device in the entrance can be equipped with one DBM01 module and the Bluetooth module will send the plate number of cars to the central console equipped with another module. Because the two modules work in PAIRA mode, they will deny the connection requests from other unrelated Bluetooth devices automatically.

AT COMMAND SET

DBM01 module provides rich AT commands for users to manipulate the modules. Some commands of DBM01 module come into effect after executing **AT+SAVE** command but for other commands they need to execute another command **AT+RESET** after using command **AT+SAVE** in order to reset the module and let it work in new parameters.

COMMAND SET	DESCRIPTION
AT+E 、 AT+FORCEK 、 AT+FORCEC 、 AT+AUTOSCAN 、 AT+NOTIFY、 AT+TXPOWER、 AT+ADVERT、 AT+BTPARAM、 AT+BTPARAM2、 AT+SLEEP	Users need to execute command AT+SAVE after using these commands in the left
AT+NAME 、 AT+UART 、 AT+FLOW 、 AT+ROLE 、 AT+PAIRM、 AT+PAIRC、 AT+PAIRA	Users need to execute command AT+SAVE and AT+RESET after using these commands in the left

Table 5: DBM01 Command Sets

When users send commands to DBM01 for the first time after powering on the module, the CTRL pin (P0.6) of module should be connect to logic low so the module can enter into command mode and start to receive AT commands. Please note if the module is in sleep mode, it might not respond to the AT commands. Please check the SLEEP MODE section for how to quit sleep mode.

1. Testing command

Command Type	Response	Description
AT	OK	Testing command

2. Inquiry command

AT+HELP	Commands: E HELP SEND CFG SAVE LOAD LOADDEFT NAME UART FLOW ROLE PAIRM PAIRC PAIRA FORCEK FORCEC CONN DISC SCAN DEVLIST	This command is used to list all the supported commands by DBM01 module
---------	---	---

	AUTOSCAN NOTIFY ADDR TXPOWER ADVERT BTPARAM BTPARAM2 SLEEP SLEEPOS RSSI RESET VER	
AT+HELP=X	Set echo on or off OK	X means the command which needs to be inquired. It will return the help information of the command

3. Echo ON/OFF command

AT+E=X	OK	Turn on/off echo function for commands being executed. X=1 means enable ECHO X=0 means disable ECHO The default setting of module is ECHO enabled. It is useful when users set the commands through Computer to display the commands they send. For MCU controlling DBM01, the ECHO function can be disabled in order to process the data better.
AT+E?	1 OK	It inquires the status of ECHO function in present module.

4. MAC inquiry command

AT+ADDR	33116AF5990 OK	It returns the MAC address of DBM01 module
---------	-------------------	--

5. Serial data format command

AT+UART=9600,n,8,1	OK	It sets the data format of serial port of DBM01. The parameters after =
--------------------	----	---

		means 9600 bps, no parity check, 8 data bits and 1 stop bit The supported data rates are: 9600 bps, 19200 bps, 38400 bps, 57600 bps, 115200 bps. The default data rate is 38400 bps
AT+E?	38400,n,8,1 OK	It displays the present data format

6. Inquiry RAM command

AT+CFG	Name: DBM BLE Role: 2 UART: 38400,n,8,1 Flow Control: 0 TX Power: 0 BT Param: 35,18,37,0,200 BT Param2: 128,250,32,10,500 Pair Mode: 0 Pair Code: 30303030 Pair Address: 000000000000 Auto Scan: 1 Notify Enable: 1 Echo Enable: 1 Force PAIRK: 0 Force CTRL: 0 Sleep On Start: 0 OK	It displays the changed parameters stored in RAM but not saved in flash. In other words the parameters are changed by AT commands but not execute the AT+SAVE command to save the parameters in Flash.
--------	--	--

- Notes:
- name → Module name
 - Role → Central module or peripheral module
 - UART → Serial port data format
 - Flow Control → Enable flow control or not
 - TX Power → Transmission power
 - BT Param → DBM01 working parameter list 1
 - BT Param2 → DBM01 working parameter list 2
 - Pair Mode → One of four types of pairing modes
 - Pair Code → Pair code in PAIRC Mode
 - Pair Address → Pair address in PAIRA Mode
 - Auto Scan → Enable auto scan function or not
 - Notify Enable → Enable event notification or not
 - Echo Enable → Echo function on or off
 - Force PAIRK → If the PAIRK pin is pulled up or down

Force CTRL → If the CTRL pin is pulled up or down

Sleep On Start → If the module enters into sleep mode when start-up.

7. Inquiry Module Name Command

AT+NAME=X	OK	Configure the name of the module to X
AT+NAME?	DBM BLE OK	It returns the present name of DBM01

8. Flow control Command

AT+FLOW=1	OK	0 → no flow control 1 → enable flow control
AT+FLOW?	0 OK	It shows present flow control function

9. Role Command

AT+ROLE=X	OK	It sets DBM01 module to central module or peripheral module 0 → Depends on ROLE pin 1 → central module 2 → peripheral module
AT+ROLE?	0 OK	It shows the role of present module

10. Inquiry Version Command

AT+VER	SW:12DBM HW:06 OK	It shows the software and hardware versions of DBM01
--------	-------------------------	--

11. Inquiry RSSI Command

AT+RSSI	-128 OK	It shows present RSSI value. It is only meaningful when the modules are in connection status
---------	------------	--

12. Reset Command

AT+RESET	OK	For some commands, they come into effect only after executing AT+SAVE and AT+RESET. Seeing table 5 for related commands
----------	----	---

13. Save Command

AT+SAVE	OK	For some commands, they can come into effect after executing AT+SAVE. Seeing table 5 for related comamnds
---------	----	---

14. FLASH Data Load Command

AT+LOAD	OK	
---------	----	--

15. Restore Factory Setting Command

AT+LOADDEFT	OK	
-------------	----	--

16. Pairing Mode Command

AT+PAIRM=X	ERROR OK	0 → Automatic pairing 1 → Pairing according to PAIRK pin 2 → Pairing according to PAIRC code 3 → Pairing according to PAIRA address
AT+PAIRM?	0 OK	It shows the present pairing mode

17. PAIRC Code Command

AT+PAIRC=X	ERROR OK	X means pairing code in PAIRC mode. It is a 4 byte Hex data. If X=0x00000000, it will quit PAIRC mode
AT+PAIRC?	00000000 OK	It shows the present pairing code

18. PAIRA Address Command

AT+PAIRA=X	OK	X means the address of the paired DBM01 module
AT+PAIRA?	9059AF1624AB OK	It shows the present pairing code

19. PAIRK Pin Control Command

AT+FORCEK=X	OK	0 → No process 1 → Virtually pull down the PAIRK
AT+ FORCEK?	0 OK	

20. CTRL Pin Control Command

AT+FORCEC=X	OK	0 → No process 1 → Virtually pull down the CTRL
AT+ FORCEC?	0 OK	

21. Connecting Targeted Peripheral Device Command

AT+CONN=X	OK	This command is only available for central module. X means the sequence number of the peripheral devices scanned by central module. X=0 means the first peripheral device being found. This command is to let the central module connect the X peripheral module.
-----------	----	---

22. Disconnect Command

AT+DISC	OK	Disconnect the present link
---------	----	-----------------------------

23. Send Data Command

AT+SEND=X	N bytes sent OK	X refers to the data needing to be sent. The data is in HEX coding and the length of data package should not exceed 20 bytes. N means the number
-----------	--------------------	--

		of bytes rendered to buffer area and not indicate the data is sent out successfully by wireless
--	--	---

24. Scan Command (central module only)

AT+SCAN	OK +DEVS: 0 found +DEVE	It triggers the central module to scan surrounding peripheral modules. The result will be transferred to the host at the form of events such as +DEVS.
---------	-------------------------------	--

25. Automatic Scan Command (central module only)

AT+AUTOSCAN=X	1 OK	0 → Disable autoscan 1 → Enable autoscan When this function is enabled, DBM01 will start scanning automatically in the situations of module start-up, scanning failure, disconnecting, etc.
AT+ AUTOSCAN?	1 OK	

26. Broadcast Command (peripheral module only)

AT+ADVERT=X	OK	0 → Stop broadcasting 1 → Start broadcasting
AT+ ADVERT?	1 OK	

27. List Peripheral Module Command (central module only)

AT+DEVLIST	+DEVS: 1 found +DEV: 0, 0x9059AF1624AB, 0, 00000000 +DEVE OK	This command will list the information of all the peripheral modules being scanned. +DEVS: shows the number of peripheral devices. Among the parameters following +DEV, 0 refers to the index of the peripheral module, 0x9059AF1624AB means the address of DBM01 module, the second 0 refers to the pairing mode and the last digits refers to the PAIRC code.
------------	---	--

		+DEVE means the searching is finished
--	--	---------------------------------------

28. Notification Command

AT+NOTIFY=X	OK	0 → DBM01 will not send +CONN notice when the module is connected or disconnected 1 → DBM01 will send +CONN notice
AT+NOTIFY?	1 OK	

29. Set TX Power Command (peripheral module only)

AT+TXPOWER=X	OK	X means the output power which DBM01 allows to be set. The values include: 4, 0, -6, -23
AT+TXPOWER?	4 OK	

30. Configure Working Parameter List1 Command (peripheral module only)

AT+BTPARAM=List1	OK	The command is used to change the response speed and power consumption of DBM01. List1 refers to the parameters list. Wrong parameters might cause the module out of service so users can use the parameters lists.
AT+ BTPARAM?	35,18,37,0,200 OK	

31. Sleep Mode Command

AT+SLEEP=X	OK	0 → No sleep 1 → Sleep when no connection 2 → Deep sleep
AT+ SLEEP?	1 OK	In deep sleep the AT commands are not available so the response only can be 0 or 1

The power consumption of DBM01 module is not only related to sleep mode but also to Working Parameters List1. The default sleep mode for DBM01 module is 0. It means the module is in

working mode all the time no matter if there is a connection or not. In this mode the module consumes the Max. power but it has the highest response time and transmission speed.

When Sleep mode is set to 1, DBM01 will enter into sleep when there is no connection and activated to normal work mode when connection is available. When the module comes back to normal work mode, the AT commands can be used and RX/TX will be normal. Users can use command AT+SLEEP=0 to quit this mode and return to normal work mode all the time. When there is no connection, the module will enter into sleep and AT commands will not be executed. Users can repeat sending <CR> (Carriage return character) to evoke the module till the host receives the correct response character from the module (Echo function should be enabled). After the module is wakened, the sleep mode will be switched to 0 and never enter into sleep automatically. Another way to evoke the module from sleep status is to impose a pulse with rising edge on the SLEEP pin.

When the Sleep mode is set to 2, the module will enter into sleep at the lowest power consumption mode no matter if there is a connection or not. In this mode the response and transmission speed are the slowest. Because AT commands are ineffective in this mode, data transmission is not available but the module still can receive data which will be informed to the host by the event +DATA. In this mode users can repeat sending <CR> (Carriage return character) to evoke the module till the host receives the correct response character from the module (Echo function should be enabled). After the module is wakened, the sleep mode will be switched to 0 and never enter into sleep automatically. Another way to evoke the module from sleep status is to impose a pulse with rising edge on the SLEEP pin.

The pull down of SLEEP Pin will forcibly let the module enter into sleep status and ignore the setting of Sleep mode (equal to sleep mode 2). The repeating input of <CR> still can't wake up the module so the only way to let the module quit sleep status is to impose a pulse with rising edge on this pin. The module then will be wakened and the sleep mode will be set to 0. If the SLEEP pin is pulled down when there is data flow on the UART port, the data transmission will be interrupted and wrong data will be sent or received. In normal conditions the SLEEP pin is usually used to evoke the module from sleep status quickly.

32. EVENTS NOTICE

In AT command mode, there are some events which can be used to monitor the status of DBM01 module.

Event Type	Event Format	Description
Connection Status	+CONN: X	0 → disconnected 1 → connected
Start Mark after scanning	+DEVS: X found	X means the number of peripheral modules being scanned
Device Information After Scanning	+DEV: 0,0x9059AF1624AB,0,00000000	The first 0 refers to the index of the peripheral module,

		0x9059AF1624AB means the address of DBM01 module, the second 0 refers to the pairing mode and the last digits refers to the PAIRC code.
End Mark After Scanning	+DEVE	
Data Received notice	+DATA: x	X refers to the received data in Hex format. When the data package is too large, the package will be split and produce multiple +DATA notices

POWER CONSUMPTION

The actual power consumption of DBM01 is not only determined by the sleep modes but also depends on the broadcasting frequency, scanning frequency, TX power, response speed and the connection status of GPIO pins. In order to let the modules work with the best performance, users need to choose the right working parameters list1 according to the applications. The default factory parameters for DBM01 module is speed priority so the power consumption is the maximum.

All of the GPIO pins are internally pull-up. When they are connected with GND, there will be leak current so it will be better to keep the unused GPIO pins floated in order to reduce power consumption. What's more the function of some GPIO pins can be realized by AT commands. For example, the command AT+ROLE=1 is equal to the pull-down of ROLE and AT+FORCEC=1 is equal to the pull-down of PAIRK.

When peripheral module is not connected, it will broadcast frequently. It will reduce the power consumption by lowering down the broadcasting frequency. The broadcasting function of peripheral module can be cancelled by AT command AT+ADVERT=0 but it will not be scanned by the central module. AT command AT+BTPARAM=List1 can be used to adjust the broadcasting frequency of peripheral module.

If the central module doesn't connect with a peripheral module, it will scan the surrounding devices frequently, which makes great contribution to the power consumption. Users also can use AT command AT+AUTOSCAN=0 to turn off the auto-scan function. It will lower down the power consumption of central module in unconnected status.

When the peripheral module is connected with a central, the working parameters list is determined by the peripheral module so the power consumption of central module will be decided by the connected peripheral module.

Num	Working Parameters List	Description
1	AT+BTPARAM=35, 18,37,0,200	Default parameters. The broadcasting frequency is 20ms so DBM01 has the highest response speed and data transmission with the maximum power consumption
2	AT+BTPARAM=800,30,50,0,200	The broadcasting frequency is 0.5s so the response time and data transmission speed and power consumption of DBM01 module are moderate
3	AT+BTPARAM=3200,70,90,0,200	The broadcasting frequency is 2s. The DBM01 module has the lowest response time and data transmission but it has the lowest power consumption so it is suitable for low data output applications.

Table 6: Working Parameters List

The output power of DBM01 also influences the power consumption. The command AT+TXPOWER only affects the peripheral module. Lower output power means lower power consumption but it will reduce communication distance. Anyway the most important factor which affects the power consumption is the sleep mode. As mentioned in the AT command set section, the sleeping of modules can be realized by AT command AT+SLEEP=X or SLEEP pin.

The pull-down of SLEEP pin will force DBM01 module to enter into sleep and the module will ignore sleep mode. Because there is a leak current when a GPIO pin is connected to GND, it is not recommended to use SLEEP pin to control the sleeping of module but this pin can be used to wake up DBM01 module quickly.

Peripheral Module @ AT+SLEEP=2			
Working parameters list	No connection	Connected without data transmission	Connected with continuous data transmission
AT+BTPARAM=35,18,37,0,200	2mA	1.6mA	2.9mA
AT+BTPARAM=800,30,50,0,200	10uA	850uA	1.8mA
AT+BTPARAM=3200,70,90,0,200	1.2uA	330uA	500uA

Table 7: Power Consumption of Peripheral Module

Central Module @ AT+AUTOSCAN=0 & AT+SLEEP=0		
No connection, No scanning	No connection, scanning	Connected
7.9mA	20mA	8mA

Table 8: Power Consumption 1 of Central Module

Central Module @ AT+AUTOSCAN=0 & AT+SLEEP=2		
No connection	Connected without data transmission	Connected with data transmission
1.2uA	330uA	500uA

Table 9: Power Consumption 2 of Central Module

ADDITIONAL INFORMATION

- Communication with IPHONE or IPAD

The DBM01 module can be used to communicate with IPHONE(or IPAD) which the latter acts as the central module to launch the connection and start communication. The DBM01 module will be used as peripheral module. LightBlue is a good APP run in IPHONE or IPAD which can be downloaded from App Store of APPLE as free. This software can search the surrounding Bluetooth devices and shows them in the list. Users can choose the DBM01 device from the list and use the commands below to fulfill data transmission.

Service UUID	ReadOnly Character	WriteOnly Character
0XFFF0	0XFFF4	0xFFF1

Table 10: DBM01 Communicating with IPHONE /IPAD

- Communicating with Android system

The old versions of Android system don't support well for Bluetooth 4.0 module. The Texas instrument also has not provided the official demonstrating software yet. Octamex intends to develop the testing APP on android system 4.3 or above.

MECHANICAL DATA

Unit:mm

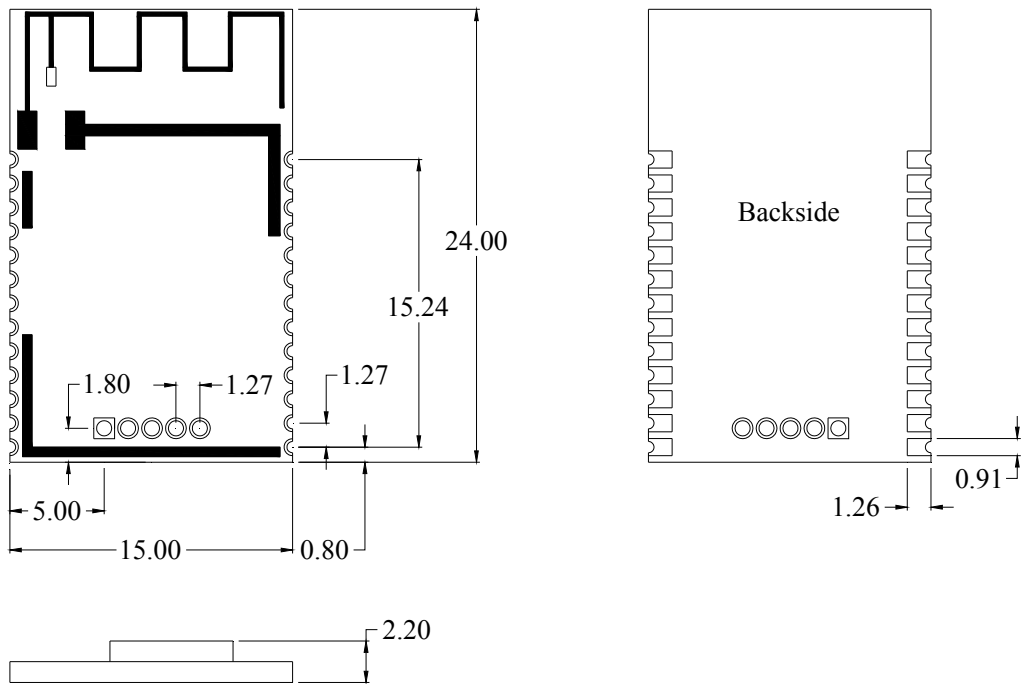

Figure 3: DBM01 Mechanical Dimension

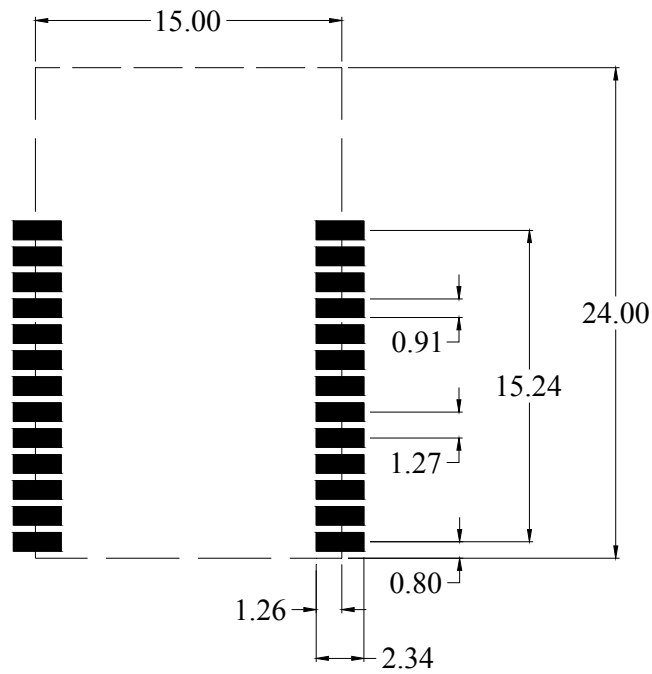

Figure 4: Soldering Pattern Reference

--	--